

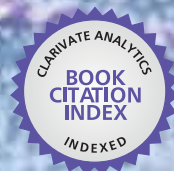

IntechOpen

# Current Frontiers in Cryobiology

*Edited by Igor I. Katkov*



WEB OF SCIENCE™





---

# **CURRENT FRONTIERS IN CRYOBIOLOGY**

---

Edited by **Igor I. Katkov**

## Current Frontiers in Cryobiology

<http://dx.doi.org/10.5772/1962>

Edited by Igor I. Katkov

### Contributors

Ali Honaramooz, Regina Celia Rodrigues Da Paz, Katuscia Cipri, Edoardo Lopez, Vincenzo Naso, King L. Chow, Wai Hung Tsang, Anja Kaczmarczyk, Bryn Funnekotter, Eric Bunn, Ricardo Mancera, Akshay Menon, Pui Ye Phang, Arwa Al-Hanbali, Loredana Zilli, Alan Copperman, Catherine Bigelow, Agnieszka Partyka, Wojciech Niżański, Małgorzata Ochota, Marian Dorcas Quain, Daisuke Kami, Heriberto Rodriguez-Martinez, Dayong Gao, Vladimir Isachenko, Raul Sanchez, Evgenia Isachenko, Jennie Rizopatron, Igor I. Katkov, Alexei Grigoryev, Oleg Chernetsov, Ayub Lulat, Sergey Moskovtsev, Konstantin Sokol, Dudin Peter, Yevgeny Sokol, Vladimir Bolyukh, Alexie Sushko, Ilya Yakhnenko, Marina Petrushko, Vladimir Pinaev, Raquel Martin-Ibañez, Outi Hovatta, Josep M. Canals, Joseph Saragusty, Juergen Liebermann, Steve Butler, David Pegg, Nirmal Babu Kantipudi, Clifford L Librach

### © The Editor(s) and the Author(s) 2012

The moral rights of the and the author(s) have been asserted.

All rights to the book as a whole are reserved by INTECH. The book as a whole (compilation) cannot be reproduced, distributed or used for commercial or non-commercial purposes without INTECH's written permission.

Enquiries concerning the use of the book should be directed to INTECH rights and permissions department ([permissions@intechopen.com](mailto:permissions@intechopen.com)).

Violations are liable to prosecution under the governing Copyright Law.



Individual chapters of this publication are distributed under the terms of the Creative Commons Attribution 3.0 Unported License which permits commercial use, distribution and reproduction of the individual chapters, provided the original author(s) and source publication are appropriately acknowledged. If so indicated, certain images may not be included under the Creative Commons license. In such cases users will need to obtain permission from the license holder to reproduce the material. More details and guidelines concerning content reuse and adaptation can be found at <http://www.intechopen.com/copyright-policy.html>.

### Notice

Statements and opinions expressed in the chapters are these of the individual contributors and not necessarily those of the editors or publisher. No responsibility is accepted for the accuracy of information contained in the published chapters. The publisher assumes no responsibility for any damage or injury to persons or property arising out of the use of any materials, instructions, methods or ideas contained in the book.

First published in Croatia, 2012 by INTECH d.o.o.

eBook (PDF) Published by IN TECH d.o.o.

Place and year of publication of eBook (PDF): Rijeka, 2019.

IntechOpen is the global imprint of IN TECH d.o.o.

Printed in Croatia

Legal deposit, Croatia: National and University Library in Zagreb

Additional hard and PDF copies can be obtained from [orders@intechopen.com](mailto:orders@intechopen.com)

Current Frontiers in Cryobiology

Edited by Igor I. Katkov

p. cm.

ISBN 978-953-51-0191-8

eBook (PDF) ISBN 978-953-51-4331-4

# We are IntechOpen, the world's leading publisher of Open Access books Built by scientists, for scientists

4,200+

Open access books available

116,000+

International authors and editors

125M+

Downloads

151

Countries delivered to

Our authors are among the  
Top 1%

most cited scientists

12.2%

Contributors from top 500 universities



WEB OF SCIENCE™

Selection of our books indexed in the Book Citation Index  
in Web of Science™ Core Collection (BKCI)

Interested in publishing with us?  
Contact [book.department@intechopen.com](mailto:book.department@intechopen.com)

Numbers displayed above are based on latest data collected.  
For more information visit [www.intechopen.com](http://www.intechopen.com)





# Meet the editor



Igor I. Katkov, PhD, is a “seasoned” cryobiologist with more than 30 years of experience in the field. He received his MSc and PhD diplomas in Kharkov, Ukraine. He has collaborated with many prominent cryobiologists, including P. Mazur, F. Ostashko, V. Grischenko, the Isachenkos, and many others. Dr Katkov has more than 130 publications and is actively working in the fields of hyper-fast kinetic vitrification, osmotic modeling, cryopreservation of adherent cells, and many other fields related to fundamental cryobiology, assisted reproduction and regenerative medicine. Igor Ivanovich is a renowned scientist and a member of Editorial Boards of the “Cryo Letters” and “Problems of Cryobiology and Cryomedicine” journals.





---

# Contents

---

## **Preface XIII**

### **Part 1 Basic Cryobiology and Kinetic Vitrification 1**

- Chapter 1 **Kinetic Vitrification of Spermatozoa of Vertebrates: What Can We Learn from Nature? 3**  
I.I. Katkov, V.F. Bolyukh, O.A. Chernetsov, P.I. Dudin, A.Y. Grigoriev, V. Isachenko, E. Isachenko, A.G.-M. Lulat, S.I. Moskovtsev, M.P. Petrushko, V.I. Pinyaev, K.M. Sokol, Y.I. Sokol, A.B. Sushko and I. Yakhnenko
- Chapter 2 **Vitrification Technique – New Possibilities for Male Gamete Low-Temperature Storage 41**  
E. Isachenko, P. Mallmann, G. Rahimi, J. Risopatròn, M. Schulz, V. Isachenko and R. Sànchez
- Chapter 3 **Cryopreservation of Human Spermatozoa by Vitrification vs. Slow Freezing: Canadian Experience 77**  
S.I. Moskovtsev, A.G.-M. Lulat and C.L. Librach
- Chapter 4 **Prevention of Lethal Osmotic Injury to Cells During Addition and Removal of Cryoprotective Agents: Theory and Technology 101**  
Dayong Gao and Xiaoming Zhou
- ### **Part 2 Stem Cells and Cryopreservation in Regenerative Medicine 137**
- Chapter 5 **Cryopreservation of Human Pluripotent Stem Cells: Are We Going in the Right Direction? 139**  
Raquel Martín-Ibáñez, Outi Hovatta and Josep M. Canals
- ### **Part 3 Human Assisted Reproduction Techniques (ART) 167**
- Chapter 6 **Vitrification of Oocytes and Embryos 169**  
Juergen Liebermann

- Chapter 7 **Oocyte Cryopreservation for the Elective Preservation of Reproductive Potential** 185  
Catherine Bigelow and Alan B. Copperman
- Chapter 8 **Cryopreservation of Testicular Tissue** 209  
Ali Honaramooz
- Part 4 Farm / Pet / Laboratory Animal ART** 229
- Chapter 9 **Cryopreservation of Porcine Gametes, Embryos and Genital Tissues: State of the Art** 231  
Heriberto Rodriguez-Martinez
- Chapter 10 **Cryopreservation of Embryos from Model Animals and Human** 259  
Wai Hung Tsang and King L. Chow
- Part 5 Cryopreservation of Wildlife Genome (Terrestrial Animals)** 291
- Chapter 11 **Genome Banking for Vertebrates Wildlife Conservation** 293  
Joseph Saragusty
- Chapter 12 **Wildlife Cats Reproductive Biotechnology** 369  
Regina Celia Rodrigues da Paz
- Part 6 Cryopreservation of Aquatic Species** 389
- Chapter 13 **Effect of Cryopreservation on Bio-Chemical Parameters, DNA Integrity, Protein Profile and Phosphorylation State of Proteins of Seawater Fish Spermatozoa** 391  
Loredana Zilli and Sebastiano Vilella
- Part 7 Cryopreservation of Plants** 415
- Chapter 14 **Current Issues in Plant Cryopreservation** 417  
Anja Kaczmarczyk, Bryn Funnekotter, Akshay Menon, Pui Ye Phang, Arwa Al-Hanbali, Eric Bunn and Ricardo L. Mancera
- Chapter 15 **Cryopreservation of Plant Genetic Resources** 439  
Daisuke Kami
- Chapter 16 **Cryopreservation of Spices Genetic Resources** 457  
K. Nirmal Babu, G. Yamuna, K. Praveen, D. Minoo, P.N. Ravindran and K.V. Peter

- Chapter 17 **Cryopreserving Vegetatively Propagated Tropical Crops –  
The Case of *Dioscorea* Species  
and *Solenostemon rotundifolius* 485**  
Marian D. Quain, Patricia Berjak,  
Elizabeth Acheampong and Marceline Egnin
- Part 8 Equipment and Assays 505**
- Chapter 18 **Precision in Cryopreservation – Equipment and Control 507**  
Stephen Butler and David Pegg
- Chapter 19 **Technologies for Cryopreservation:  
Overview and Innovation 527**  
Edoardo Lopez, Katuscia Cipri and Vincenzo Naso
- Chapter 20 **Methods of Assessment of Cryopreserved Semen 547**  
Agnieszka Partyka, Wojciech Niżański and Małgorzata Ochota



---

## Preface

---

Almost a decade has passed since the last textbook on the science of cryobiology and the most common methods of cryopreservation was published [Fuller *et al*, 2007], to which we will refer as “*the previous book*” here and below. When it was published, it became a useful guide for both “seasoned” cryobiologists and those who had just started their journey to this fascinating science.

However, there have been some serious tectonic shifts in cryobiology, which were perhaps not seen on the surface but may have a profound effect on both the future of cryobiology and on the development of new cryopreservation methods. We feel that it is time to revise the previous paradigms and dogmas, discuss the conceptually new cryobiological ideas and introduce the recently emerged practical methods of cryopreservation. The present books, *Current Frontiers in Cryobiology* [Katkov, 2012A] (referred here as *Book 1*) and *Current Frontiers in Cryopreservation* [Katkov, 2012B] (*Book 2*), will serve the purpose. These two books are not a substitute for *the previous book* but are rather complementary, so we highly recommend to all readers who want to know the background on which *the current books* were written to read *the previous book* as well.

Before we describe the current books, let us first briefly compare them to the previous book in retrospective. First of all, there were some very promising directions a decade ago that unfortunately did not meet the expectations. Molecular biology and genetics, particularly in regards to expression of stress proteins and other pathways related to the cell injury, have not introduced any serious breakthroughs except for the use of ROCK inhibitors for cryopreservation of human embryonic and induced pluripotent stem cells. The latter really was a revolutionary discovery, which however, was not made by cryobiologists; it was just “picked up” by them from the Watanabe’s seminal work [Watanabe *et al*, 2007] (see the Chapter by Martin- Ibáñez in *Book 1* for details). In general, however, all those molecular biology tools have helped the solution but have not solved the cryopreservation problems *per se*. One of the backlashes of this new era is that the “traditional” cryobiologists now have little chances of getting a grant from many funding agencies such as NIH, whose panels are dominated by molecular biologists and geneticists, unless the applicant is willing to study those pathways and use of transcriptomics, proteomics, metabolomics, and other “omics”. Yet, all those very expensive tools have so far added a little to the science of cryobiology, and

especially to the practices of cryopreservation. Moreover, it is sad to see the how some new publications “rediscover the wheel”, repeating many achievements of cryobiologists that had been done one or two decades before but were not referred as full size papers on PubMed, and these novel rediscoveries are often done at a much greater cost. We must agree with the author of *Foreword* of the previous book, who insightfully wrote “*I see now much of the early ground being replowed, often by equally empirical methods, albeit at far greater expenses...The concept of science as a community of colleagues engaged in public service ... has been eroded by the cost of research and the emergence of industry as not only a major source of research funding but as the ultimate exploiter of the results, and we have no choice but to play the game*” (Foreword in [Fuller *et al*, 2007] by H. Meryman). However, we hope that might change in the future and that an alliance between cryobiology and molecular and cellular biology will bring *real* practical fruits.

The slogan “*Let Us Learn from Mother Nature*”, while being attractive *per se* (it is actually imbedded in the title of our first Chapter by Katkov *et al* in *Book 1*), must be taken with a grain of salt. Yes, Mother Nature has liquid crystals in biological membranes, but LCD TV screens were invented by man. Yes, there are rotifers and other “molecular motors” in cells, but the wheel was discovered and built by the human race. And finally, there are TV, radio, internal combustion engines, and many other devices and apparatuses that have no close analogy in wildlife. Similarly, while some robust creatures are well adapted to survive for short time at up to  $-20^{\circ}\text{C}$ , there is no place on Earth that cools down below the glass transition temperature of water ( $-136^{\circ}\text{C}$ ), and there is no place on Earth where liquid nitrogen is present. Ergo, practically no one natural biosystem can adapt to such low temperatures just by natural selection, it needs human help to be stabilized for infinite time at  $-196^{\circ}\text{C}$ . Thus, while learning something from the natural phenomena, it is our strong opinion that we should not rely on them too much: the money for supplying an Antarctica deep lake drilling or a Mars expedition can be spent much more efficiently and *usefully for humankind* if channeled to the development of a new controllable freezer for cryopreservation of large tissues and organs, similar for instance, to the described in our *Book 1* by Butler and Pegg.

The next large area where the progress has been quite slower than it was expected a decade ago is lyophilization and desiccation of cells of vertebrates. So far, there is no compelling evidence that would convince us that there is a method of freeze-drying or desiccation that has produced *viable* mammalian cells that can be stored for sufficient amount of time ( $> 2$  years) at temperature above  $+4^{\circ}\text{C}$  despite the fact that the opposite was claimed many times in the last 50 years. We briefly explored this aspect in our *Chapter 1* of *Book 1*. We think that this field has remained to be trapped in a set of scientific misconceptions, such as the possibility of drying the sample to the glass transition  $T_g$  that is above the final temperature or drying  $T_{dr,f}$ , or the related misleading concept of the possibility of substantial movement of water in a sample below its glass transition. We think that such statements violate the laws of

thermodynamics and the definition of the vitreous phase as the state with enormous viscosity, as well as that it is in contradiction with the Stokes-Einstein Law of diffusion. Numerous reports, which state  $T_g$  of the sample as high as +60°C while drying was stopped at, say,  $T_{dr,f} = +20^\circ\text{C}$  are *incorrect*. Such overestimation of  $T_g$  (which in fact is 20-25 degrees lower than  $T_{dr,f}$ ) lead to unsubstantiated expectations of long stability at supra-zero, even ambient temperatures at relatively *high* water content of the sample, which has never proven the case in thorough experiments (with some reservation to platelets as rather "*cell debris*" than true cells). All these data, if checked properly, are in fact either artifacts - the results of incorrect gravimetric measurements or the use of inaccurate methods such as DSC. We are confident that the real viscosity, not those *mysterious* high temperature DSC peaks, should be measured for correct determination of the *biostabilization*  $T_g$  (defined as the point at which viscosity reaches  $10 \times 10^{13.6}$  Pa x sec).

And as *the last but not the least in our list* is the notion that all those ice-blockers, freeze and shock proteins, and other promising from a decade ago classes of molecules have not so far shown to be used in cryopreservation protocols alone but always in a concert with *ole good* permeable cryoprotectants and impermeable sugars, and other low molecular weight molecules, which have been around for decades. This is especially true in regards to vitrification, specifically of organs: "*the promise of the 21<sup>st</sup> century medicine*" has remained as far from the completion as it was 25+ years ago with the report on *equilibrium* vitrification of a kidney by Fahy and colleagues. On the other hand, the assisted reproduction cryobiology is rapidly moving toward *kinetic* vitrification, the very method of cryopreservation described by the most prominent pioneer of cryopreservation, Father Basil Luyett, more than 7 decades ago. We specifically dedicated our *Chapter 1* both to the memory of this brilliant scientist and to the detailed analysis of the situation, the difference between the two approaches to vitrification (*kinetic vs. equilibrium*), and to a quite opposite foreseeable future for them.

On the other hand, there are new directions (or the old ones, replowed with deeper and more thorough plowing techniques) on the horizon of cryobiology. Among them, we can mention the attractiveness of cryopreservation of *adherent* cells (often in monolayers) not only for the benefit of the cells *per se* (by avoiding anoikis triggered apoptosis, etc), but mainly for the convenience of the rapidly emerging field of cell based high throughput and high content analyses, where cells can be frozen, stored, shipped, and *ready-to-go* after thawing directly in multi-well plates (see Chapter by Martín-Ibáñez in *Book 1*).

The other serious breakthrough that was missed by many authors a decade ago is the kinetic vitrification of sperm and the emergence of what we call "*Race for the Pace*", a set of new devices for ultra-fast cooling of samples such as Open Pulled Straws, Microdroplets, Vitrification on the Solid Surface, VitMaster (slush cooling), Cryogenic Oscillating Heat Pipes, Quartz Capillaries, and some others (see Chapter by Cipri *et al* in *Book 1*). We think that many of these devices are rather transient to a new generation

of hyper-fast coolers and warmers, but yet, the rapid ascent of kinetic vitrification is the phenomenon that has been largely missed and often simply ignored by the “classical cryobiologists” at the end of the last century and the beginning of the current one. Our books dedicate a lot of space to those aspects and their future directions.

There are also some other differences between our books and *the previous book* published by CRC, which are mainly determined by the very nature of how the Open Access operates. To begin with, our books are closely related but yet are different. *Book 1* contains mainly reviews that were written by the leaders in the field and were solicited by the Editor. In contrast, *Book 2* (in general, with some exceptions) is dedicated mostly to the reports of concrete methods of cryopreservation, and its chapters are often written by young or emerging scientists who want to make their discoveries public as soon as possible. The Editor is well aware of how discouraging and often devastating the reviewing process in “standard” journals can be just because the reviewer(s) did not share innovative ideas proposed by the author, even though the experimental or mathematical aspects of the manuscript raised no questions. The Editor of these books has reviewed all submitted chapters, about a dozen of them has been rejected, and among 41 published chapters, many were revised one, two, or sometimes three times. But that was always regarding the quality of the manuscripts, not the quality of the author’s science; if I sometimes disagreed with the author’s opinion, I then “*let the cryo people go*” with their perception, not mine or the one of some external reviewer. In the revolutionary spirit of Open Access, let the common reader, not an elitist reviewer, be the judge in the end!

Another “democratic” aspect in our books in the times of globalization is that the contributions were made by people from 27 countries from *all* continents (except Antarctica). Editor *greatly* appreciates the *invaluable* contribution of the American, Australian, British, Canadian, and New Zealand scientists to the field, and 10 out of 42 Chapters in our books were contributed by authors from those countries. However, cryobiology has long existed in many other languages and cultures. We found the tone of some, especially “historical” reviews written by prominent cryobiologists that may make an impression that the scientists of *that* linguistic domain have predominantly contributed to cryobiology quite uncomfortable; in other words: “*If it is not published in English - it doesn’t exist*” so to speak. In contrast to such biases, the seminal works of Luyett, Smirnov, Jahnel, Boutron, Milovanov, Cassou, Ostashko, Sumida, Kopeika, and many other scientists whose first language of publication and/or mother tongue were not English, but whose *pioneering* contribution to the theory and practice of low temperature stabilization has been recognized over the World, is also highly regarded in our books.

Yet another difference is that the chapters of our books are grouped into topics (Sections) that are “subject oriented” rather than loosely flocked to the “Themes” so none would wonder why one chapter on freezing of plants is in one section, while another one ends up in another. The sections are the same for both our *books*, the only



difference is the type of the paper as described earlier, yet in many cases, this difference is rather vague: we do not consider chapters in *Book 2* as “second class” at all: *Books 1* and *2* are inseparable. The sections and chapters of the books are as follows:

Section “*Basic Cryobiology and Kinetic Vitrification*” opens *Book 1*. The first, and the two following chapters are dedicated to kinetic vitrification as the re-emerging method of cryopreservation. Chapter 1 by Katkov and colleagues reiterates the idea that basically all methods of long-term stabilization of cells are in fact different ways (the authors identify 5 of them) of vitrification of the intracellular milieu. The chapter gives a detailed thermodynamical description and analysis of the methods. The second part of the chapter is dedicated to the kinetic vitrification of human and animal spermatozoa, the concept of the “*Universal Cryopreservation Protocol*” and what the author called “*Race for the Pace*”, though the last one needs a separate chapter and is only mentioned briefly as one of the future directions. The chapter by *Isachenko and colleagues* tells the story of successful vitrification of human and animal spermatozoa, and its emerging as a valuable tool applied to the assisted reproduction technologies. The third chapter, by a Canadian group (*Moskovtsev et al*) is an *independent* report of the success of vitrification of human sperm without permeable (and potentially toxic) cryoprotectants (vitrificants) with certain modifications of the *Isachenko’s* method. The chapter by Gao & Zhou is dedicated to the basic cryobiology of osmotic effects, prevention of the osmotic injury, as well as to the equipment for the optimal addition and elution of osmotically active permeable cryoprotective agents (CPAs).

Section “*Stem Cells and Cryopreservation in Regenerative Medicine*” in *Book 1* is presented by a review by Martín-Ibáñez on cryopreservation of human *pluripotent* stem cells; it is the cutting edge of the contemporary cryobiological science where major discoveries have been made very recently. Cryopreservation of *adult* rat mesenchymal stem cells by vitrification is the theme of the chapter by Bahadori *et al* in *Book 2*. It is the one of the chapters when the Editor disagrees with the evaluation of the convenience of cryopreservation of stem cells by vitrification in small containers such OPS, but as we said before, we judged the experimental science, not the concept, and the former one was self-evidently good. The chapter by Campbell & Brockbank reports very interesting results on cryopreservation of adherent smooth muscle and endothelial cells, a direction that, as we mentioned before, may bring about some interesting practical applications. The other two chapters in *Book 2* are the one by U. Santos and colleagues, dedicated to cryopreservation of musculoskeletal cells and tissues, and the other application of regenerative medicine - cryopreservation of allograft for knee ligament construction is the theme of the Chapter by Bitar *et al*.

Section “*Human Assisted Reproduction Techniques (ART)*” opens with a review by Liebermann on vitrification of embryos and oocytes, a fast developing method of ART. Juergen and Michael Tucker have edited an excellent book dedicated to the use of vitrification in human ART [Liebermann & Tucker, 2007] that we highly recommend for reading to the specialists in the field. This review in *Book 1* summarizes the latest

achievements in the area. Another chapter in *Book 1* (Bigelow & Copperman) is also dedicated to cryopreservation of human oocytes, and altogether, both chapters provide a good glance at the comparative advantages of slow freezing vs. vitrification in cryopreservation of human eggs. As the background in cryopreservation of human spermatozoa is extensively covered by three chapters of the first section in *Book 1*, the third chapter of this section written by Honaramooz discusses the recent advances in cryopreservation of testicular tissues. The chapter in *Book 2* by Criado covers a very “hot” topic of contamination associated with vitrification in the so called “open systems”, in which there is a direct contact (or a possibility of such) of the vitrified sample with liquid nitrogen. The chapter also provides a comprehensive review of current containers used for vitrification in human ART.

The section “*Farm / Pet/ Laboratory Animal ART*” is generically related to the previous section, but with an emphasis on animal reproductive cells and tissues. The first chapter in *Book 1* by Rodriguez-Martinez covers the cryopreservation of porcine (pig) gametes, embryos and genital tissues. It is followed by a chapter on cryopreservation of embryos of model animals, written by Tsang & Chow. *Book 2* contains a series of reports and mini-reviews on cryopreservation of boar (Kaeoket) and rat (Yamashiro & Sato) spermatozoa, cryopreservation of genetic diversity (sperm, oocytes, embryos, somatic cells) of rabbit species by Jolly *et al*, cryopreservation of ovarian tissues of large domestic animals (cow, pig and sheep) and non-primates (macaque) by Milenkovic and colleagues, and cryopreservation of reproductive cells of domestic animals (Neto *et al*). While there is a certain overlap in the coverage among those chapters, we feel that such diversity enriches the *Book 2* as different points of view are considered.

Section titled “*Cryopreservation of Wildlife Genome*”, particularly of terrestrial vertebrate species, is comprehensively covered by Saragusty and is supplemented by a review on cryopreservation of genome of wild *Felidae* by Paz in *Book 1*.

Section “*Cryopreservation of Aquatic Species*” lacks a general review but several aspects are covered in a variety of chapters. Zilli & Vilella (*Book 1*) discuss the effect of cryopreservation on bio-chemical parameters, DNA integrity, protein profile and phosphorylation state of proteins of seawater fish spermatozoa, with a similar topic, but at a different angle and with their own recent experimental results, covered by Li and colleagues in *Book 2*. This book also contains several experimental reports on cryopreservation of sperm of freshwater species, such as European pikeperch and catfish (Bokor *et al*), a variety of Malaysian freshwater species (Chew), brown trout and koi carp (Bozkurt *et al*) and African giant catfish (Omitogun *et al*).

The section titled “*Cryopreservation in Plants*” is the most *populous* and is represented by four chapters in *Book 1* and five chapters in *Book 2*. Two extensive reviews by Kaczmarczyk *et al* and by Kami cover general aspects of plant cryopreservation. Again, while those two chapters overlap in many aspects, they are rather complementary. The third chapter in *Book 1*, written by Babu and colleagues, is

dedicated to cryopreservation of species of spices plants, while the review by Quain *et al* discusses the current advances in cryopreservation of vegetatively propagated tropical crops. Similar subject (vegetatively propagated crops), but with an emphasis on the thermal analysis of the cryopreservation methods using DSC, is covered by Zámečník *et al* in *Book 2*. In the same book, Martinez-Montero and colleagues cover current frontiers in cryopreservation of sugarcane and pineapple, C. Santos reports the results of cryopreservation of cork oak, and Radha *et al* discuss cryopreservation of a medicinal Indian plant of *Icacinaeae* species. The Chapter by Burritt covers an interesting topic of action of proline as a “natural” multi-functional cryoprotectant that is accumulated in higher plants under stress, and can be considered as an attractive CPA candidate for cryopreservation in general.

Section “*Equipment and Assays*” is the last but definitely not the least important section of these two books, as the entire progress of cryobiology and cryopreservation depends on the development of devices and containers for cryopreservation, and proper and adequate assays of cryopreserved cells after resuscitation. The first chapter in *Book 1*, by Butler & Pegg, covers the precision in and control of cryopreservation, the pivotal components in the modern cryopreservation technologies. While this chapter covers mostly slow (equilibrium) programmed freezing, it is supplemented by a review by Cipri *et al*, which discusses some novel equipment and carriers, particularly for vitrification. To some extent it complements the last sub-section of our chapter 1, but we have to emphasize that none of the devices described in the Cipri’s chapter can achieve the very rapid rates of cooling as many of the inventors claim. For example, the notion that *VitMaster* can achieve as high as 135,000 °C/min is largely overestimated even for very small samples, as slush freezing does not completely eliminate the Leidenfrost effect. In regard to assays, Partyka and colleagues review the methods of assessment of viability of cryopreserved sperm, many of which can be adapted to other types of cells as well. Finally, Pérez Campos *et al* present some interesting ideas on using X-ray diffraction for the assessment of quality of cryopreserved tissues in tissue banks in *Book 2*.

In conclusion, *Books 1* and *2* cover a vast variety of topics regarding the current development of both fundamental cryobiology and practical aspects of cryopreservation, and we hope they will help the researches to grasp the background, state of the art, and future of this captivating and very important field of Life Sciences.

**Igor I. Katkov, Ph.D.**

Head of Cryobiology and Biostabilization  
Stem Cell Center

Burnham-Sanford Institute for Medical Research  
and

Chief Scientific Officer of CELLTRONIX  
San Diego, California,

USA

## References

- Fuller B. J., Lane N., & Benson E.E., Eds. (2004). *Life in the Frozen State*. CRC Press, 701 p., ISBN 978-041-524-700-9
- Katkov I.I., Ed. (2012A). *Current Frontiers in Cryobiology*. InTech Open Access Books, ISBN 979-953-307-300-1.
- Katkov I.I., Ed. (2012B). *Current Frontiers in Cryopreservation*. InTech Open Access Books, ISBN 979-953-307-743-6.
- Tucker M. J. & Liebermann J., Eds. (2007). *Vitrification in Assisted Reproduction: A User's Manual and Troubleshooting Guide*. London, UK, Infroma Healthcare, 320 p., ISBN: 978-041-540-882-0.
- Watanabe K., *et al* (2007). "A ROCK inhibitor permits survival of human embryonic stem cells." *Nat Biotechnol* 25: 681-6.

# **Part 1**

## **Basic Cryobiology and Kinetic Vitrification**



# Kinetic Vitrification of Spermatozoa of Vertebrates: What Can We Learn from Nature?

I.I. Katkov\*\* et al.\*

*CELLTRONIX and Sanford-Burnham Institute for Medical Research,  
San Diego, California,  
USA*

*Dedicated to the memory of Father Basile J. Luyet (1897-1974)*

## 1. Introduction

This as well as two other related Chapters, by Isachenko *et al.* and Moskovtsev *et al.*, open this Book neither accidentally nor by the Editor's preferences to his friends and collaborators; the reasons, in fact, lie quite deeper:

Why *sperm*? Cryobiology had actually started from freezing sperm. We will skip all those very early anecdotes but should mention the Spallanzani attempt to freeze frog semen in the 18th century [Spallanzani, 1780]. Cryobiology as a science started with revolutionizing work of Father Luyet and other scientists of the late 1930's and 1940's, who we can collectively call "*the pioneers of the cryobiological frontiers*" (see the following sub-Chapter). There were several reasons why sperm was chosen, which included easiness in obtaining the samples, clear evidence of viability (moving – not moving, though later it was figured that everything was not so easy in this sophisticated living "*cruise missile*"), and importance for the farming industry with the emergence of systematic selective breeding (especially in cattle) with a powerful tool – artificial insemination (AI). AI started with the revolutionary work of W. Heape, I.I. Ivanov and other scientists at the dawn of the 20<sup>th</sup> century and was further developed by V.K. Milovanov in the 1930's as a viable breeding technology (see [Foote,

---

\* V.F. Bolyukh<sup>2</sup>, O.A. Chernetsov<sup>3</sup>, P.I. Dudin<sup>4</sup>, A.Y. Grigoriev<sup>5</sup>, V. Isachenko<sup>6</sup>, E. Isachenko<sup>6</sup>, A.G.-M. Lulat<sup>7</sup>, S.I. Moskovtsev<sup>7,8</sup>, M.P. Petrushko<sup>9</sup>, V.I. Pinyaev<sup>9</sup>, K.M. Sokol<sup>10</sup>, Y.I. Sokol<sup>2</sup>, A.B. Sushko<sup>3</sup> and I. Yakhnenko<sup>1</sup>

<sup>1</sup> CELLTRONIX and Sanford-Burnham Institute for Medical Research, San Diego, California, USA

<sup>2</sup> Kharkov National Technical University "KhPI", Kharkov, Ukraine

<sup>3</sup> Animal Reproduction Center, Kulinichi, Kharkov region, Ukraine

<sup>4</sup> Raptor Restoration and Reintroduction Program, National Reserve "Galichya Gora", Voronezh region, Russia

<sup>5</sup> Kharkov Zoo, Kharkov, Ukraine

<sup>6</sup> Dept. Obstetrics and Gynecology, Ulm University, Germany

<sup>7</sup> CReATe Fertility Center, Toronto, Ontario, Canada

<sup>8</sup> Dep. Obstetrics and Gynecology, Toronto University, Toronto, Ontario, Canada

<sup>9</sup> ART Clinic, Kharkov, Ukraine

<sup>10</sup> Kharkov National Medical University, Kharkov, Ukraine

\*\* Corresponding Author

2002] and [Milovanov, 1962] for detailed history of AI). Whatever case(s) for such specific interest to freezing sperm had been, it was the first subject of systematic research in cryobiology. For a long time after the 1940's, cryopreservation (CP) of sperm would be overshadowed by successes in CP of other types of cells: peripheral blood, blood, embryos, cord blood, stem cells, and other cells, tissues and organs. However, the recent progress and rejuvenation of the old method of sperm vitrification (see following Chapters by Isachenko and Moskovtsev) makes us to believe that it can bring a new shift in the cryobiological paradigm, which we will discuss later in this Chapter.

Why *vitrification*? As we will discuss below, the only method of stable and long-term (practically infinite) preservation and storage of any perishable biological materials, particularly cells, (a.k.a. "*biostabilization*") is to keep them in the glassy (vitreous) state. This was clearly understood by Father Luyet when he titled his pioneering work "*The vitrification of organic colloids and of protoplasm*" and "*Revival of frog's spermatozoa vitrified in liquid air*" [Luyet & Hodapp, 1938; Luyet, 1937]. He and other "*pioneers of the cryobiological frontiers*" clearly understood 70 years ago that only glassy state would insure stable and non-lethal preservation of cells. With time, we saw the development of a variety of biopreservation methods, such as slow freezing (which, as we will see below, is just a way of achieving glassy state inside the cells and within their close vicinity - cells cannot live neither within ice without a glassy border between cells and ice, or with ice within them). Another method is *equilibrium vitrification* with large amounts of exogenous thickeners (vitrification agents, or VFAs). Eventually, many cryobiologists, especially the new generation and many practitioners, have forgotten that all those methods are basically different ways of achieving vitrification of the intracellular milieu (or at least, without the formation of intracellular types of ice that kill the cells) and the cell's close extracellular vicinity. This has led to several common misconceptions:

- The fact that permeable substances such as glycerol, dimethyl sulfoxide (DMSO), ethylene glycol (EG), propylene glycol (PG or PrOH) and some other small permeable compounds play absolutely different roles during *slow freezing*, when they serve mainly as osmotic buffers and during *vitrification* (VF), when they play the role of thickeners so they increase viscosity and deplete growth and propagation of ice. As a result, in both cases, these substances are called "*cryoprotective agents*" (CPA's) across the board even though the concentrations used, the modes of addition and elution, and the mechanisms of action are very different for the cases of *slow freezing* (SF) *vs. equilibrium vitrification* (E-VF) and *kinetic vitrification* (K-VF) (we will explain the difference between E-VF and K-VF later). We prefer to distinguish these two roles and call 10% of DMSO used for *slow freezing* of stem cells as "*CPA*" and 40% of DMSO used for *equilibrium VF* of embryos of kidneys as "*VFA*". As we can see however, for *kinetic VF*, even 10% of glycerol can help vitrify the cells and can be used as the vitrification agent (with some reservation).
- The second misconception that has an even larger implication and can be seen mainly in the work of practitioners is that slow freezing is often called "*cryopreservation*" and is contrasted to vitrification. It is *all* essentially cryopreservation, just by different methods. Moreover, it is actually *vice versa*: slow freezing ("*cryopreservation*" in their terms) is just a way of intracellular *vitrification* with ice being present in the extracellular compartment (see below for details). We can see such erroneous terminology in some Chapters of this Book (especially in Volume 2). The Editor, however, has decided to keep a *democratic* approach and not impose his point of view, thereby letting the reader understand their mistakes after reading this Chapter for future publications. It is the authors' choice to use



incorrect terminology, and as the result, to be a target of criticism in following publications.

- The drastic decrease in the rate of degradation at low temperatures is contributed not *only* (and not mainly) by the simple Arrhenius decreases of the rate of a chemical reaction at lower temperature as all molecules *per se* move slower at lower temperatures even in a vacuum or air as suggested in [Suzuki, 2006]. The practically infinite stability in the vitreous state is achieved *mainly* due to the enormous increase in *viscosity* of the surrounding milieu, which at the glass transition point is determined as  $10^{13.6}$  Pa x sec. At such conditions, according to the Einstein-Stokes Law, the destructive molecules such as reactive oxygen species can reach a biomolecule in time that is longer than the age of the universe [Katkov & Levine, 2004]. This is true in the opposite way as well; the degradation of the sperm after freeze-drying at different temperatures, as observed by Suzuki, had occurred mainly because the cells were kept at some level above the crucial temperature of the glass transition ( $T_g$ ): As higher the cells are kept above  $T_g$ , as more soft (rubbery) and later liquid the sample became, therefore the cells degraded more rapidly. We can judge from Fig. 1 in Suzuki's paper that intracellular  $T_g$  was above  $-80^{\circ}\text{C}$  but below  $+4^{\circ}\text{C}$ , a typical scenario for *lyophilization* of sperm and other cells.

Why *kinetic*? As we will also discuss below, the modern shift from Fahy's *equilibrium* back to Luyet's *kinetic* vitrification has brought not only clear technical advantages and better survival of oocytes and embryos. The resurrection and successful re-emergence by the Isachenkos of the Luyet's method in regards to the very subject he and other "*pioneers of the cryobiological frontiers*" attempted to preserve more than 70 years ago - the sperm, has not only brought a simple and convenient technique to the field of assisted reproduction (human spermatozoa first, then animal ones followed). As we can see later in this Chapter, both success of K-VF for some species of sperm and failure of the same method for the others would prompt us to a more general idea: the "*Universal Cryopreservation Protocol*", which could have a much broader impact and if realized physically by a new type of cryogenic devices that would insure hyperfast cooling and warming, it would shift the whole cryopreservation paradigm. We feel that we will soon witness some sort of a "*Kinetic Vitrification Spring*" as to draw a political analogy, and that is why we have put these three Chapters at the spearhead of the Book.

**In this Chapter**, we summarize the basic thermodynamical and biophysical distinctions between K-VF, E-VF, slow freezing (SF), analyze present and predict future developments that will widen the K-VF niche, and hypothesize why K-VF of some species of sperm was more successful than the others. We then briefly explore our idea that with the development of a new generation of hyper-fast cooling devices (up to several hundred of thousand  $^{\circ}\text{C}/\text{min}$ ), we will witness the "*Race for the Pace*" for the *Universal Cryopreservation Protocol* without any exogenous VFA's that can be applicable to *any* cell type.

## **2. Brief history of kinetic vitrification of sperm and cryobiology in general related to the goal of this Chapter**

### **2.1 Early attempts of *kinetic* vitrification of sperm and other cells**

In the dawn of cryopreservation, vitrification of small samples by ultra-fast cooling (tens of thousands  $^{\circ}\text{C}/\text{min}$ ) without additional thickening and ice-blocking agents (VFAs), which is

referred here as kinetic VF, had been considered as the major method of cryopreservation at that time [Graevsky, 1948a, b; Graevsky & Medvedeva, 1948; Hoagland & Pincus, 1942; Jahnel, 1938; Luyet & Hodapp, 1938; Luyet, 1937; Park *et al.*, 2004; Schaffner, 1942]. Note that some authors contributed the first understanding of the importance of vitrification for biopreservation to an earlier work of Walter Stiles [Stiles, 1930], as it, for example, is done in [Fahy & Rall, 2007]; we think, the Stiles's notion however was vague and had had a marginal impact. It was Luyet's work, which would make cryopreservation a *science*. From the outset, he recognized that ice damage must be avoided and vitrification could be a method for long-term preservation of cell viability [Luyet, 1937]. In 1938 Luyet and Hodapp achieved survival of frog spermatozoa vitrified by plunging into liquid air [Luyet & Hodapp, 1938], and later several Western European groups reported their experiences with attempts in kinetic vitrification of fowl [Schaffner, 1942], human [Hoagland & Pincus, 1942; Jahnel, 1938; Parkes, 1945], and rabbit spermatozoa [Hoagland & Pincus, 1942] with varying success. While not directly related to the K-VF of sperm, a clear notion of vitrification as the only way of viable stabilization of cells has been expressed by Graevsky in USSR. As he worked with bacteria, it was natural to use a bacterial sample collection loop to freeze the cells in thin pellicles [Graevsky, 1948a, b]. A similar approach was used by Hoagland and Pincus in Germany in 1942 [Hoagland & Pincus, 1942], which seems a very natural approach for very fast K-VF. Yet, in the money-driven 21<sup>st</sup> century, the term "*Cryoloop*" is registered as a trademark. Apparently, those early scientists would have infringed the trademark law now!

These early efforts of K-VF of sperm did not receive the recognition they deserved, hindered by the low repeatability and poor survival, as well as difficulties in communication due to various "iron walls" that existed between scientists of the Western Allies, Germany and USSR in the era of WWII followed by the Cold War.

## 2.2 The rise of slow freezing

The breakthrough came from an independent discovery of the protective role of a permeable CPA glycerol by two groups in 1948-49 [Polge *et al.*, 1949; Smirnov, 1949]. The high permeability of glycerol to the sperm membrane in conjunction to relatively low toxicity seemed to be the crucial factor; both groups unsuccessfully tried either non-permeable sugars such as glucose (Parkes's group) or very permeable but very toxic lower alcohols such as ethanol or methanol (Smirnov). The high membrane permeability of glycerol and, thus, fast penetration inside the cells allowed to preserve the cells using slow (10-40 °C/min) freezing, and very moderate warming rates by direct thawing on air or in a water bath. It then became the mainstream of the cryopreservation methods, and a vast variety of cell species of different biological taxa have been preserved by slow (also called *equilibrium*) freezing. It revolutionized two very important fields: the cattle industry (with preservation of bovine sperm and later bovine embryos) and cryopreservation of blood components. It is worth noting that 12 years before the discovery of Parkes's and Smirnov's groups, Bernstein and Petropavlovski had reported the protective role of glycerol during the freezing of sperm [Bernstein & Petropavlovski, 1937] to -20°C, but that work had gone largely unnoticed.

With the development of Peter Mazur's equations and the 2-factor hypothesis of cryodamage [Mazur, 1963; Mazur *et al.*, 1972] and work of other cryobiologists on slow (equilibrium) freezing in 1960's, it became clear that a particular cell would need its own optimal cryopreservation protocol, which would largely depend on the cell cryobiological and physiological parameters as well as on the type of cryoprotective agents (CPA's) used.

Particularly, equilibrium CP of embryos would require much slower pace of cooling (0.3-1 °C/min) so the whole cryopreservation process would take several hours.

Following cryopreservation of animal spermatozoa, the successful slow freezing of human sperm with glycerol followed, and the first birth was reported by Sherman and colleagues 1964 [Perloff *et al.*, 1964]. It was then followed by the use of frozen spermatozoa for practically all assisted reproduction techniques (ART) mentioned above. Yet, since his first publications, Sherman had questioned the efficiency of glycerol as the ideal CPA for human spermatozoa [Sherman, 1963, 1964]. The addition and especially removal of permeable osmotically active cryoprotective agents (cryoprotectants) during freezing and warming can induce a lethal mechanical stress *per se*. Further problems include the chemical toxicity of cryoprotectants and the possible negative influence on the genetic apparatus of the mammalian spermatozoa [Gilmore *et al.*, 1997].

### 2.3 The emerging of *equilibrium* vitrification

On the other hand, Greg Fahy and colleagues [Fahy *et al.*, 1984] reported the vitrification of a whole organ--a rabbit kidney--using high pressure and *extremely high concentrations* of permeable vitrificants. We will call that approach, which for all intents and purposes will be clarified later, *equilibrium* vitrification. The needs of more quick and robust methods of cryopreservation of mammalian embryos had been clear, since Mazur and colleagues and Wilmot had obtained the "frozen mice" by SF in 1972 [Whittingham *et al.*, 1972; Wilmot, 1972]. Plus, Fahy's initial report led to the collaboration between him and W. Rall (former Mazur's student, who specialized in freezing embryos) and the first successful vitrification of mouse embryos was reported a year after Fahy's first report [Rall & Fahy, 1985]. The first human baby from a vitrified embryo was reported in 1990 ?? [Gordts *et al.*, 1990]. Since then, vitrification has become an equally spread assisted reproduction technique (ART) as programmed slow freezing of embryos and, especially, oocytes for *in vitro* fertility (IVF) (see [Rezazadeh *et al.*, 2009] for examples and background).

For detailed state of the art of vitrification of reproduction cells, see several Chapters of this Book and Book 2, as well an excellent book by Tucker and Lieberman [Tucker & Liebermann, 2007]. Several Chapters in that book will be referred throughout this Chapter as well. Particularly, an interesting history and even possible natural occurrence of E-VF in nature is described in the Chapter 1A of that book by Fahy and Rall ("*Certain Alaskan beetles dehydrate sufficiently to generate concentrations of up to 10 mol/L of endogenous glycerol, 26 which is enough to vitrify aqueous solutions under laboratory conditions*") [Fahy & Rall, 2007]. Note, however that this particular Chapter 1A is substantially biased against K-VF in favor of E-VF, which we will address throughout the following sub-chapters, and toward the founder of the method, Father Luyet, including some far from diplomatic language escapades. That part will be addressed at the end of the Chapter.

### 2.4 Vitrification of *the majority* of reproductive cells is moving from *equilibrium* to *kinetic* approach

While slow freezing showed its limitations for certain cell types (e.g. oocytes), a new era started when Rall and Fahy vitrified mouse embryos [Rall & Fahy, 1985] using essentially the same high concentrations of vitrificants vitrified by Fahy *et al.* used in its original report [Fahy *et al.*, 1984]. However, such high concentrations (40-60 % v/v) of VFA's such as

glycerol, DMSO, and PG are osmotically damaging and chemically toxic so they are intolerable for many cells such as oocytes and spermatozoa, many of which can withstand at best 10-15% DMSO or glycerol. As a result, researchers moved from *equilibrium* VF to much more rapid *kinetic* vitrification that requires much lower concentrations. It is especially clear for CP of oocyte, which cannot tolerate either slow freezing or equilibrium VF apparently due to their cytoskeletal osmotic fragility. To date, many methods and sample carriers have been designed for K-VF of oocytes and embryos, but they all require small sample volumes and precise timing, which makes them vulnerable to technical errors. We will further explore this aspect in a sub-Chapter below.

## 2.5 Resurrection and rise of *kinetic* vitrification of sperm: the Isachenkos' contribution

The true "second wind" of the *kinetic* VF was brought in with re-discovering of VF of human spermatozoa *without* any exogenous vitrificants (a.k.a., „cryoprotectants“ even though they play a completely different role than in slow equilibrium freezing) by the Isachenkos and their colleagues. It came with two seminal papers and two presentations in 2002 and 2003, which, as one of the author remembers, stirred a pot and met a lot of resistance and denial from vitrification experts and other prominent "classical" cryobiologists. In 2002, Vladimir and Evgenia Isachenkos and their colleagues reported that human sperm can be vitrified without endogenous vitrificants ("cryoprotectants" as they called it). It worked with the same success or even better than slow freezing [Nawroth *et al.*, 2002], so the Isachenkos showed that it *did* work. Later, Igor Katkov joined the team and tried to explain *why* it actually worked in [Isachenko *et al.*, 2003] and gave a presentation in CRYO-2003 in Coimbra [Katkov *et al.*, 2003]). It was clearly emphasized that at least three factors might have played a crucial role in the successful K-VF of human sperm without exogenous permeating vitrificants: i) small size of the cells, ii) compartmentalization, and iii) high amount and *concentration* of endogenous natural vitrificants such polymers, sugars and nucleotides. We will explore those aspects later in some detail. This quite novel at the time notion is so "*well known*" now that does not even need mentioning the source (e.g., p.649 [Isachenko *et al.*, 2011]); however, it was not so "*obvious*" back in 2003. Here we want to emphasize that despite of skepticism, denial, or even open hostility towards publications and presentations faced by the Isachenkos (and by Katkov as their strong proponent), the method had matured into a *technology*, which proved to be robust and feasible for ART practitioners as well brought food for thoughts to those who works in the realm of basic cryobiology. Most importantly, the results led to the birth of healthy babies and at least one group has repeated the Isachenko method and has obtained good results completely independently- they report their data in Chapter 3 [Moskovtsev *et al.*, 2012]. The authors dedicate a separate Chapter 2 in this Book for summarizing their achievements [Isachenko *et al.*, 2012]. Below, we not only briefly explore progress of the method but also show that even as the staunchest opponent of the method (more precisely, interpretation of the results) as Dr. Fahy has also evolved in his perception of "legitimacy" of *kinetic* vitrification, which we had never doubted at the beginning.

The Isachenko group has recently expanded K-VF method to other mammalian species (dogs) and to an even more distance vertebrate taxon, the fish (see below and also a separate Chapter [Isachenko *et al.*, 2012]). However, our experiments on K-VF of sperm of rodents was not so successful, and attempts of kinetic VF of sperm of the polar bear and raptor birds (falcons and

eagles) failed completely, which actually would prompt us to an even more interesting hypothesis of "The Universal Preservation Protocol" and prediction of the "Race for the Pace".

### 3. Five basic methods of long-term cell biostabilization: *pro's & con's*

#### 3.1 All five basic methods of long-term biostabilization cell requires vitrification of the intracellular milieu

We have defined 5 *major ways* of cell stabilization that all lead to low- or high-temperature VF of intracellular milieu as we outlined in [Katkov *et al.*, 2006], which are shown on a schematic phase diagram (Fig. 1) adapted from [Devireddy & Thirumala, 2011] with some corrections and additions.

Equilibrium (slow) freezing (points A-B' in green) allows to freeze-out the bulk of both extracellular and intracellular water (which escapes from the cell as the extracellular liquid phase becomes more and more concentrated) to ice. Finally, the cells are vitrified in the inter-ice "channels" that are surrounded by ice but always make a connected network (due to barometric restrictions) and surrounded by ice. Yet, the glass transition temperature in those channels is still low so the cells must be stored in LN<sub>2</sub> at -196 °C, in nitrogen vapor, or in industrial freezers at -130°C and for a limited time at higher temperature than the  $T_g$  of water (around -136°C), for example in more accessible -80°C freezers. This is the mainstream conventional cryopreservation, which in the majority of cases requires the use of permeable and impermeable cryoprotective agents (CPAs).

Ice-free *equilibrium* vitrification (E-VF) of cell suspensions, tissues, and organs at very low temperatures and moderate to high rates of freezing (points E-F in red). This method requires the use of high concentrations of vitrificants, which elevates the viscosity of the milieu and prevents the ice formation during cooling and de-vitrification (sometimes called re-crystallization, which is not exactly the same) during warming. Some researchers [Fahy & Rall, 2007] refer to this method as "*vitrification proper*", and in its "pure form" (see below) has had very limited success in preserving animal oocytes, embryos, some tissues and *one* organ, as well as some plant specimens.

*Intracellular* ice-free *kinetic* vitrification of a bulk solution by very fast (abrupt) plunging into a cooling agent such as liquid nitrogen (points G-H in purple). The extremely high rate of cooling ( $10^4$ - $10^6$  °C/min) and practically instant warming prevents ice formation inside the cells (the ice still can be formed outside but it has no time to cause any osmotic damage to the cells as K-VF occurs in fractions of a second). As the result, it does not require the use of potentially toxic high concentrations of "CPAs" (vitrificants) or no permeable exogenous vitrificants at all, it is referred to as "*CPA-free vitrification*" by the Isachenkos in regards to sperm. We deliberately include in this method cooling of sperm at much lower rates because the very high  $T_g$  of the intracellular milieu does not require such high rates. This is one of the major themes of this chapter.

Slow freezing to moderately low (around -40 °C -- -60°C) temperatures, which comprises two steps; i) primary drying - sublimation of the bulk of ice at very high vacuum (points A-D, and ii) secondary drying of the 'cake' at elevated (up to +30-40 °C) temperatures (points D-C). This method is called *lyophilization* and it is widely used in food production, microbiology and in the pharmaceutical industry; but so far it has had very limited applications in the preservation of *animal* cells and higher plants.

High temperature vitrification of a highly dehydrated sample (desiccation) and its stabilization by air/vacuum drying at temperatures above 0°C is so no ice is formed (points A-C in orange). In some sources, it also erroneously called “lyopreservation” [Chakraborty *et al.*, 2011], which is incorrect as “lyo” implies sublimation (Greek *luien-* loosing of ice during sublimation (<http://dictionary.reference.com/browse/lyo->). In contrast, the Greek word *xero* means “dry” (<http://dictionary.reference.com/browse/xero->), thus “xerophile organisms”, or even the Xerox machine! Subsequently, xeroprotective agents such as trehalose are often used to prevent damage associated with high levels of dehydration when it is used in secondary drying during freeze-drying, and during the whole desiccation cycle. Note that the temperature of drying  $T_{dr}$  is *always* above the glass transition temperature of the sample  $T_g$  (blue curve) for both methods on definition (otherwise, neither sublimation nor evaporation will occur due to extremely high viscosity). For stable storage on another hand, the temperature of storage  $T_{st}$  must be *below*  $T_g$ , so the conditions of stable drying are following  $T_{st} < T_g < T_{dr(f)}$  (final temperature of drying). Many papers on drying of biologicals report  $T_g$  above  $T_{dr}$ , which is incorrect (see [Katkov & Levine, 2004] for details and possible explanation of such “paradox”). It can explain instability of samples at long storage [Suzuki, 2006] that are often claimed to have  $T_g$  +60-70 °C while in fact they barely exceed 0°C or fall within the negative range and cannot be long-term stored at ambient temperatures.

The first three methods imply the low temperature and thus, are in the scope of these two books (“cryo” means cold). Biostabilization above 0°C is often considered as a part of the preservation science and traditionally reported on the cryo-meeting and published in the specialized journals such as “Cryobiology”, “CryoLetters” and “Problems of Cryobiology and Cryomedicine” (a bilingual journal of the Institute for Cryobiology in Kharkov, Ukraine). We deliberately excluded those topics from the scope of our Books as they need special consideration; nonetheless, we will briefly discuss some aspects below.

### **3.2 At present, desiccation and especially lyophilization can *not* be considered as major approaches for biostabilization of *viable* cells**

Despite the reports of “successful” xeropreservation and lyophilization of live vertebrate cells from time to time by many groups including prominent cryobiologists since the end of 1940’s, with three notable reports of Meryman and the birth of a cow called “Desicca”(see [Suzuki, 2006] for an excellent mini-review on the topic), it turned out that neither of the methods to date have proven to produce *stable* and *viable* cells that could be stored for *long* periods of time. It mainly contributes to the fact that even for such good vitrificants, such as proteins, achieving a true high  $T_g$  coincides with very low water content (in a range of 0.3 g H<sub>2</sub>O per 1 g dry weight), which apparently is not sustainable by vertebrate cells insofar. Whether the very recent reports by Devireddy and Thirumala [Devireddy & Thirumala, 2011] and by the Mehmet Toner’s group [Chakraborty *et al.*, 2011] will change the situation, or they will fade away as all the proposed methods have so far needs to be seen. Our approach is expressed in [Katkov & Levine, 2004; Katkov *et al.*, 2006; Katkov, 2008]. The discussion of what has been done wrong so far, and what could and should be done, would need a separate Chapter, and as we said before, is out of the scope of this Book. However, there are two things that should be mentioned.

### **3.2.1 Freeze-drying/desiccation of spermatozoa has not produced motile and viable cells but it fits for intracellular sperm injection (ICSI) as it stabilizes the nucleus**

First, we have to remember that “successful (i.e., bringing offspring) freeze-drying or drying of spermatozoa” is a confusing and actually misleading statement. The *properly* freeze-dried/desiccated spermatozoa are dead, they are never motile, and neither do they have intact acrosome (in the majority of cases). It is the genetic apparatuses, which include such excellent endogenous vitrificants as proteins (e.g., histones), and at lesser extent, DNA that indeed can be stabilized at high temperatures (above 0°C) for long time by xeropreservation (preferably) or by lyophilization (if secondary drying is done properly). Naturally, if intracellular sperm injection (ICSI) is performed, both methods can and do bring offspring (see [Suzuki, 2006] for references).

### **3.2.2 On reasoning of creating “xerobanks” of dried genetic material**

Secondly, as the nucleus of somatic cells can be kept intact after desiccation, it (theoretically) can be used for cloning by somatic-cell intracellular nuclear transfer (SCNT). So, those two aspects, ICSI and SCNT raise the question whether the xerobanks of both gametes and somatic cells should be created for human, model (laboratory), agricultural and wildlife species. We personally believe (though it might change with the time) that except for xerobanks of sperm of laboratory animals, such as transgenic mice and rats, for which both ICSI and SCNT have been well established [Katkov, 2008], the other types of xerobanks are not a necessity, and people should focus their resources and money (which are often scarce in this field) on the methods that have been proven to produce viable cells (i.e. on cryopreservation). In situations where the cold chain is not as easily available (for example, for the preservation of a genome of species that are on the verge of extinction), drying could be considered as the last resort, but for now, it should not be considered as an alternative to cryobanks. That might change where ICSI and SCNT become routine for many species, but so far we should concentrate on CP. And again, it is gametes, embryos and other reproductive cells that should be preserved first to save genetic material of endangered species even after their death [Maksudov *et al.*, 2009] while, for example, the CP of stem and other somatic cells should be kept as the last resort when the reproductive cells are unavailable. Note, that some other authors of this Book are much more optimistic on that matter of both drying (e.g., the Chapter by Joseph Saragusty ([Saragusty, 2012] sub-chapters 2.3 and 4.2), and cryobanks of stem cells for restoration of species ([Saragusty, 2012], sub-chapter 4.3).

### **3.3 Slow freezing: Still the mainstream of cryopreservation but...**

As we mentioned above, the discovery of “enigmatic glycerol” [Polge *et al.*, 1949; Smirnov, 1949] led to the explosion of methods of cryopreservation and types of species cryopreserved and development of the first cryobanks that marked the 1950’s. It revolutionized first the cattle industry, than blood transfusion and many others followed. However, while many of them being successful, the method *per se* remained semi-empirical. However, it has changed with introduction of the 2-factor hypothesis and the equations for the equilibrium slow freezing (minimal intracellular ice formation) by Peter Mazur [Mazur, 1963; Mazur *et al.*, 1972]. Using this truly fundamental approach, Mazur and colleagues in USA and Ian Wilmut in UK were able to cryopreserve the mouse embryo [Whittingham *et al.*, 1972; Wilmut, 1972]. Since then, slow freezing has been the mainstream of modern cryobiology, and while VF is an

emerging method that will one day replace SF for many types of cells it has not been done yet: right now SF is an imperative for the majority of cell types.

With the development of Peter Mazur's equations and the 2-factor hypothesis of cryodamage and work of other cryobiologists on slow (equilibrium) freezing in 1960s, it became clear that a particular cell would need its own optimal cryopreservation protocol, which would largely depend on the cell cryobiological and physiological parameters as well as on the type of cryoprotective agents (CPAs) used. Particularly, equilibrium freezing of embryos would require very slow pace of cooling (0.3-1 °C/min) so the whole cryopreservation process would take several hours. In contrast, for small oblate (flat) ellipsoids such as the red blood cells (RBCs) with an excellent surface-to area ratio, which would allow them to lose water very quickly, the optimal freezing rate of cooling would be in the range of several thousand °C/min. Thus, if we consider an intermediate cooling rate, say 10 °C/min, it would kill oocytes at a very fast rate due to the intracellular ice formation (IIF). But the same cooling rate is too slow for RBC's so they will be dead, due to excessive shrinkage and prolonged degradation ("solute effects"). Yet, for lymphocytes, which are intermediate between oocytes and RBC's that rate would be optimal.

Addition of a CPA shifts the survival curve toward the lower rate and higher survival, which indicates that the CPA protects mostly during suboptimal cooling (see Fig. 2) acting as an osmotic buffer that prevents excessive shrinkage and other "solute effects" [Lovell, 1953; Mazur, 1970, 1984; Mazur & Koshimoto, 2002]. The effect of protective action of the CPA is much more pronounced for larger bone marrow cells while small erythrocytes perfectly survive the absence of CPA if cooled fast enough. The optimal concentration, however, is in the same magnitude of 1- 2 M. Note that the mechanism of cryoprotective action of CPAs such as glycerol or DMSO at slow sub-optimal cooling rates is absolutely different and works at much lower concentrations than their role as vitrificants ("thickeners") that elevate the viscosity during vitrification (VF). From that standpoint, they should NOT be called "CPAs" but rather "VFAs" in case of VF.

Thus, the optimal ("*maximum maximorum*") concentration of the CPA (more precisely, the combination of concentration of CPA *and* rate of cooling) are unique for a particular type of cells. These two concepts are illustrated in Figures 2 and 3. The bottom line is that SF often needs elaborate multi-step protocols, which requires special equipment, and it can do exceptionally well, especially if combined with other "tricks" that are specific to the particular species of cells. A good, recent example is the CP of human pluripotent (embryonic and induced alike) stem cells (hESC's and iPSC's respectively). Introduction of i) multi-step freezing, ii) ROCK inhibitors in combination with full cell dissociation, and iii) freezing pluripotent SC's in adherent stage as they are prone to *anoikis* (cell death after cell are detached from extracellular matrix, [Wagh *et al.*, 2011]) have dramatically increased survival and functionality of human pluripotent cells after SF ([Katkov *et al.*, 2011; Li *et al.*, 2008; Martin-Ibanez *et al.*, 2009; Mollamohammadi *et al.*, 2009; Stubban *et al.*, 2007; Ware & Baran, 2007], see Chapter by Martin-Ibanez [Martin-Ibanez, 2012] in this Book). It now highly supersedes various vitrification techniques proposed from time to time [Beier *et al.*, 2011; Reubinoff *et al.*, 2001; Zhou *et al.*, 2004] despite what is claimed otherwise by the authors.

However, the strengths of SF freezing can be its weaknesses as well: it indeed needs *elaborative* protocols that have to be developed for each new species of cells separately. Secondly, it is difficult to implement for CP of large chunks of tissues, and especially if we are talking about CP of a whole organ. Yet, the methods and equipment are being developed, see a chapter by Butler in our Book [Butler & Pegg, 2012].



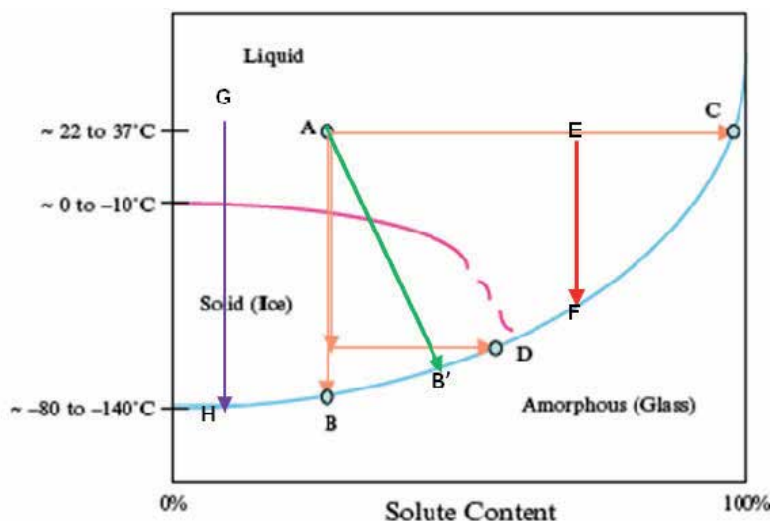

Fig. 1. Five ways of vitrification: A corrected and supplemented phase diagram adapted from [Devireddy & Thirumala, 2011].

**Light Blue** line represents the glass temperature  $T_g$  curve of the sample.

1. Points **A-B'** (**green**): *slow equilibrium freezing*, often called *cryopreservation per se*. Note, that the solute concentration is dynamically changing during freezing of extracellular ice so the original authors' line **A-B** (**orange**) is substituted by **A-B'** (**green**).

2. Points **E-F** (**red**): *equilibrium vitrification* (often referred as VF per se). The very viscous solution of the permeable vitrificant (solute) prevents the formation and/or growth of both intracellular and *extracellular* ice the sample can vitrify without the ice phase practically at *any rate* of cooling and warming (the **E-F** is locate at higher concentration than the line of freezing (heterogeneous ice nucleation) shows in a sketchy form in magento color crosses the  $T_g$  line at lower concentrations and only two phases, amorphous and liquid, exist on the right side of the x-axis).

3. Points **G-H** (**purple**): *kinetic vitrification* that occurs *intracellularly* at a much lower concentration of the vitrificant or even without permeable VFA. This however, requires much higher rates of cooling and warming so the damaging ice crystals cannot be formed during rapid cooling and re-crystallization (de-vitrification) will be blocked and, and thus, will not damage the cells during very fast warming.

See also other set of phase diagrams in the Fig. 4 and explanation in the text.

4. Points **A-D-C** (**orange**): *freeze-drying (lyophilization)* (not **A-D**, as originally is stated in [Devireddy & Thirumala, 2011]). **A-D** (orange) represents freezing and sublimation of ice (primary drying) followed by elevation of temperature of drying above  $0^\circ\text{C}$  (secondary drying) **D-C**.

5. Points **A-C** (**orange**): *desiccation (xeropreservation)* is either vacuum or air/humidity chamber drying where the temperature of drying is always above  $0^\circ\text{C}$  so no freezing phase is present. Note that the temperature drying  $T_{dr}$  is *always* above the glass transition temperature of the sample  $T_g$  (blue curve) on definition (otherwise, evaporation will not occur due to extremely high viscosity), while for stable storage, the temperature of storage  $T_{st}$  must be *below*  $T_g$ , so the conditions of stable drying are following  $T_{st} < T_g < T_{dr}$  (final). Many papers on drying of biological reports  $T_g$  above  $T_{dr}$ , which as incorrect, see [Katkov and Levine,  $T_g$ ] for details and possible explanation of such "paradox". It can explain instability of samples at long storage [Suzuki, 2006] that are often claimed to have  $T_g +60-70^\circ\text{C}$ .

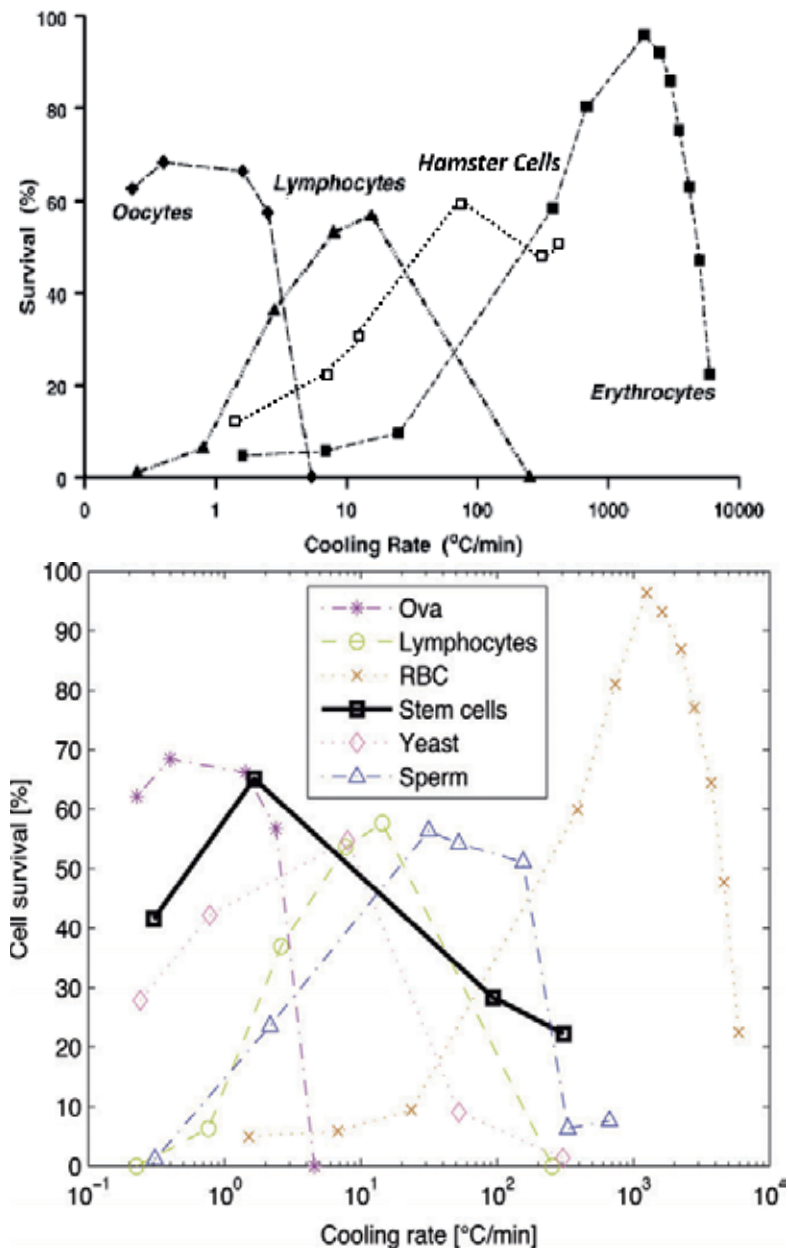

Fig. 2. The two-factor hypothesis of the cryoinjury by Peter Mazur: survival of cells of different size (oocytes  $\gg$  lymphocytes  $>$  hamster cells  $\gg$  erythrocytes) as function of the cooling rate. **Top:** Mazur's original graph, adapted from [Mazur *et al.*, 1972; Mazur *et al.*, 2008]. **Bottom:** Updated for stem cells (large size), yeast moderate) and sperm (slow) in [Cipri *et al.*, 2010]. Note that "slow (sub-optimal) and "fast" (supra-optimal) freezing in this case largely depends on the cells size: e.g., the rate of cooling 10 °C/min is very fast for oocytes (lethal IIF), very slow for erythrocytes ('damage due to the "solute effects") and close to the optimal for lymphocytes.

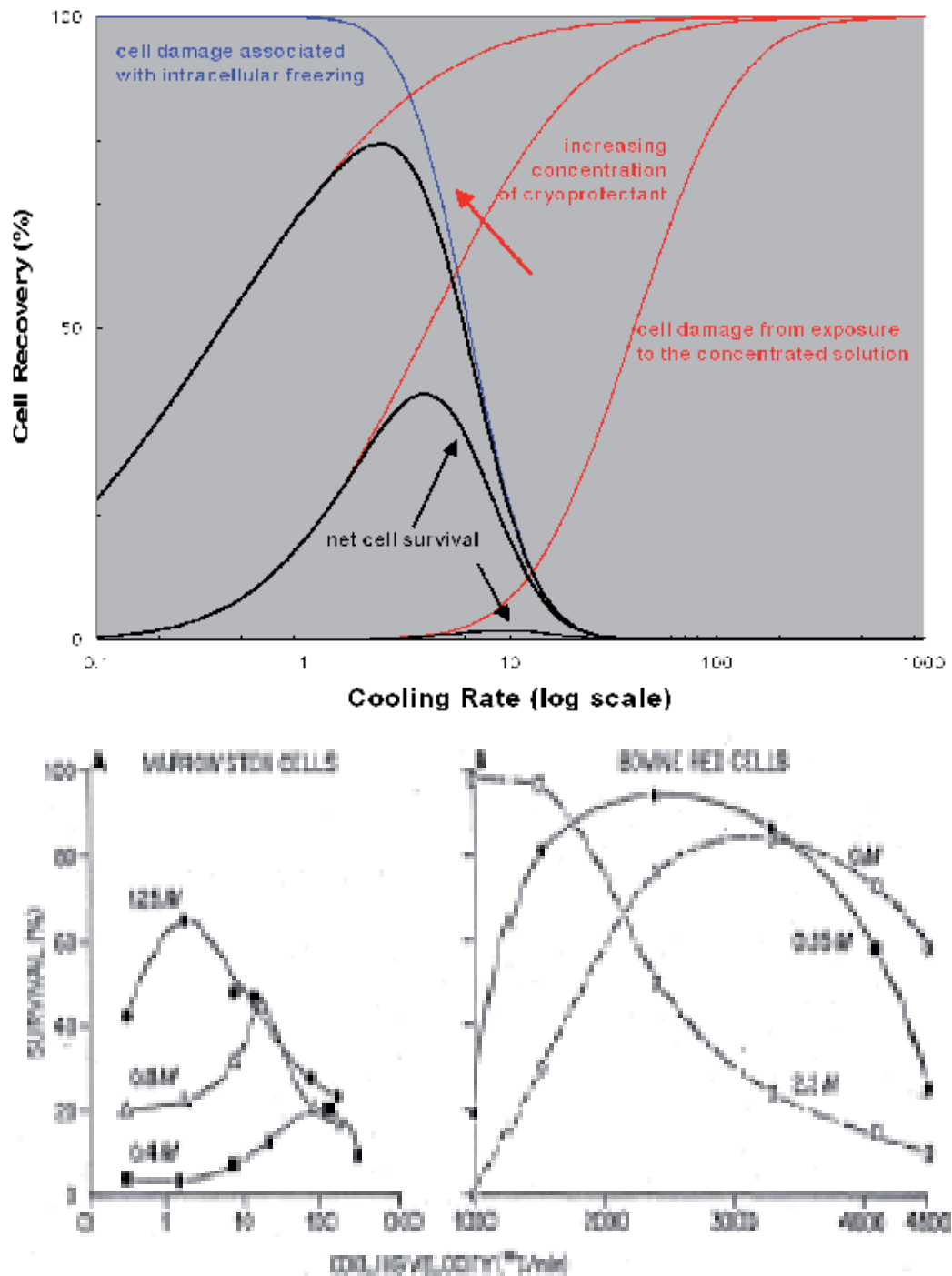

Fig. 3. The role of a cryoprotective agent (CPA) at slow freezing: Survival of cells of different size (marrow cells, the left panel >> erythrocytes on the right) as function of CPA concentration and cooling rate. Adapted from [Mazur, 1970].

### 3.4 Equilibrium vitrification and “magic” ice blockers: True 21<sup>st</sup> century medicine or “Fahy’s tyranny” and the spearhead of cryonics pseudo-science?

On the other hand, Greg Fahy and colleagues [Fahy *et al.*, 1984] reported vitrification of the whole organ (i.e. kidney), and later report E-VF of mouse embryo by Bill Rall and Greg Fahy [Rall & Fahy, 1985]. Since, the fate of VF of these two types of cells and fields split dramatically: E-VF of the whole organ has been essentially *stuck in the rut*, with *very few progress*, that has been reported mostly by the Fahy’s group *per se* [Fahy *et al.*, 2009] despite of 25 years of research and substantial amount of financial support that the author received from many sources including taxpayers money. For example, accordingly the Fahy’s company with a promising name “21<sup>st</sup> Century Medicine” (21 CM), posted on their Wikipedia site “In 2004 21CM received a \$900,000 grant from the U.S. National Institutes of Health (NIH) to develop solutions and processes to improve human heart transplantations” [Wikipedia, 2011a]. Since 1+ million dollars (including previous Phase I) in funding and eight years after that announcement, we have not found any progress report or reliable publication on that topic from the company’s scientists in scientific peer-reviewed journal. The vitrification of a heart (even an animal one) is not even close to realization apparently.

The company and its scientific team heavily rely on so called “ice-blockers”, chemical substances that block the propagation of ice in big samples cooled very slowly, thus helping vitrification. The company has made progress in the development a pipeline of such reagents. However, they are used mostly as “helpers” to lower the osmotic and chemical toxicity of the enormous concentrations of “common” vitrificants that are necessary for equilibrium (slow vitrification). Whether that approach will ever meet real progress in the remaining 88 years of the 21<sup>st</sup> century medicine, needs to be seen.

Nonetheless, Dr. Fahy has been very proactive in promoting *equilibrium* vitrification and denying *kinetic* one whenever and wherever it is possible. He basically ignores and calls it “*quasi vitrification*” (e.g., in [Fahy & Rall, 2007]), and in doing so he contradicts himself within three pages of his own review [Fahy & Rall, 2007]! In Fig. 1A.1, he placed the start of citations on vitrification of cells and organs. Of course, he starts counting from his publication 1984 totally ignoring the *earlier* work of Luyet, Boutron, Farrant and other scientists, the very work that Fahy is discussing is a couple of sub-chapters later. Yet, it was he, “*the world’s foremost expert in cryopreservation by vitrification*” ([http://en.wikipedia.org/wiki/Twenty-First\\_Century\\_Medicine](http://en.wikipedia.org/wiki/Twenty-First_Century_Medicine)), who “*truly*” vitrified cells *first*. We will come back to this attitude a bit later when we compare E-VF and K-VF. Now, we only say that while his chapter in that book is #1A, the majority of the next 19 Chapters in fact describe various *kinetic* vitrification techniques with small size and fast cooling and warming, a typical pattern of K-VF. Few people even mentioned the term ice-blockers, fewer used it in reproduction practice, mainly as “helpers” (see our explanation above).

Who has been truly benefitting from Fahy’s and his colleagues work? The people that have been engaged in a pseudo-scientific activity called ‘*cryonics*’ (<http://en.wikipedia.org/wiki/Cryonics>) They freeze deceased people, or sometimes even just their heads or brains (as did Saul Kent ([http://en.wikipedia.org/wiki/Saul\\_Kent](http://en.wikipedia.org/wiki/Saul_Kent)), the founder of the “21<sup>st</sup> CM” ([http://www.biomarkerinc.com/saul\\_kent\\_page.html](http://www.biomarkerinc.com/saul_kent_page.html)) in the hope that one day the dead will be “*resurrected*” (?!), or even that the brain can be somehow ‘*translocated*’ into a new body. This is at least science fiction and naive beliefs (a type of “*transhumanism*”) and at most a charlatanic snake oil scheme aimed “*to skim off big bucks*” from the human tragedy so

it has as much in common with cryobiology as astrology with astronomy or alchemy with chemistry. Not surprisingly, cryonicists are banned from publication in all scientific cryobiological journals and from the membership in the cryo-societies as their activities have nothing to do with real scientific premises. Yet, they skillfully wrap their messages, post some valid statements, and add some useful websites, for example on physics of glass transition (apparently, they have good physicists among their “disciples”) to make cryonics seem like a *legitimate* science. And of course, they cite Fahy’s and Brian Wowk’s work wherever they can. They actually admit that they buy those ice-blockers from the “21 CM”. They are very active in Wikipedia so we can see all biographies of prominent cryonicists, and even much less prominent and rather obscure ones like a former bookkeeper Danila Medvedev in Russia [Wikipedia, 2011c], which the company “KrioRus” proudly announces how many bodies and other parts of humans (including some brains, which they call “Neurovitrification”!), dogs, cats and birds they “vitrified” [Wikipedia, 2011b]. Of course, you can find in Wiki also the biographies of Greg Fahy, Brian Wok, and a detailed description of the “21 CM” company. None of these scientists has ever claimed any of the cryonics beliefs openly (they value their scientific carriers as well as an ability to apply for NIH money, for example, which considers cryonics as a pseudo-science), and we don’t imply that those cryobiologists and the *current* “21 CM” management are “hidden cryonicists”. Moreover, the Company’s website clearly distances itself from cryonics (<http://www.21cm.com/cryobiology.html>). However, the fact that cryonics companies and organizations heavily rely on E-VF and ice-blockers as the major method of preservation and future *resurrection*, their connection, both “*ideological*”, (e.g., hiring a *very* controversial Ukrainian scientist and former 21 CM employee Yuri Pichugin) and financial (being presumably valued customers of the “21 CM” by buying those ice-blockers) is self-evident (<http://www.cryonics.org/century.html>, <http://en.wikipedia.org/wiki/Cryonics>, <http://cryonics.org/yuri.html>).

### **3.5 Modern methods of vitrification of reproductive, stem and other germplasm cells are in the realm of *kinetic* vitrification, but still many questions remain**

The fate of the second direction of vitrification, which was initiated with the paper by Rall and Fahy [Rall & Fahy, 1985] on E-VF of embryos, was completely different: it definitely has not been stuck in the rut but rather quite opposite. The use of vitrification for cryopreservation of reproductive cells and tissues has boomed over the last 20+ years since that seminal paper was published. However, the modern methods of VF of oocytes, embryos, sperm, ovarian and testicular tissue are in fact the varieties of *kinetic* vitrification. Elaborative multi-step protocols of the addition of VFA’s before VF and elution of them after warming have been developed to decrease the toxic and osmotic effects of vitrification. Some of those methods are covered by other Chapters or our Books 1 and 2 and by the above-mentioned excellent book by Tucker and Lieberman [Tucker & Liebermann, 2007]. Up to now, a vast variety of carriers has been developed as well. They are summarized in an excellent review by Saragusty and Arav [Saragusty & Arav, 2011] and is reproduced on Fig. 4.

While there is still a debate over what is better for a particular cell type or species, slow freezing or kinetic vitrification, the latter one is gaining ground, particularly for VF of oocytes, thanks to ART scientists and practitioners such as Kuwayama, Vajta, Sheldon, Liebermann, Tucker and many others. Note however, that sometime that “cold war” may

erupt and evolve into a “hot war” when it comes to which set of VF media, the protocol, and the carrier are better. Thus, while being faster and simpler than slow freezing (though much farther from automation and “full proof”), vitrification at this moment has been struggling basically with the same problem as the SF has been plagued with: each type of cells, the carrier, and VF media need own protocol, and very often a VF media that work for open carries are too diluted for closed carriers, while using open carriers raises concern of contamination etc. The bottom line is that *kinetic* vitrification as it is now, offers a vast variety of the methods, that have to be checked and adjusted when a new type of cells of/or new species of animals are in consideration.

As we can see later, our experience with vitrification led us to conclude that it might change soon, but before moving further, we have to look in more detail at the distinction and principal differences between equilibrium and kinetic vitrification from the standpoint of thermodynamics. In other words, we have to look at the supplemental phase diagram, or as we call it here, the “Fahy’s diagram” as it was first published and explained in detail from the cryobiological audience by Fahy and colleagues [Fahy *et al.*, 1984].

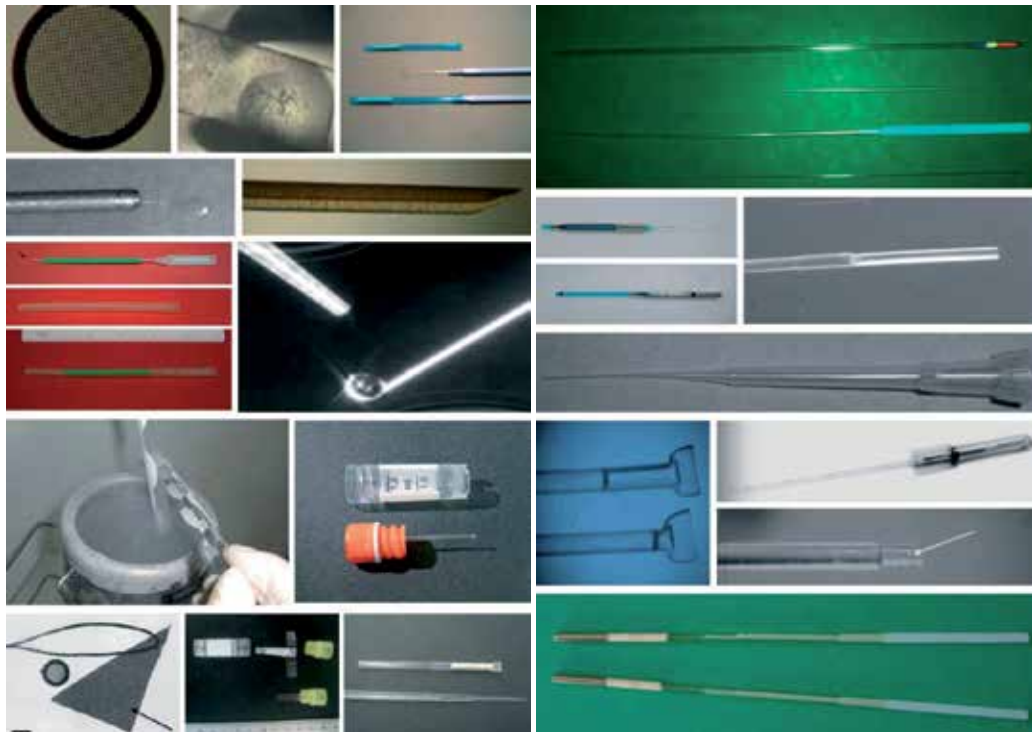

A

B

Fig. 4. Vitrification carrier systems [Saragusty & Arav, 2011].

**A:** surface carriers. **First row:** electron microscope grid, minimum drop size; Cryotop; **Second row:** Cryoloop, Hemi-straw; **Third row:** Cryoleaf, fiber plug, **Fourth row:** direct cover VF, VF

spatula; **Fifth row:** nylon mesh - arrow points at the nylon mesh, plastic blade, Vitri-Inga. **B:** tubing carriers. **First row** (top to the bottom): 0.25-mL mini-straw, 0.25 ml mini-straw, Open-pulled straw (OPS), Superfine OPS (SOPS), Flexipet-denuding pipette (170  $\mu\text{m}$  end hole); **Second row:** CryoTip (open and loaded), high-security vitrification device; **Third row:** pipette tip, **Fourth row:** sealed pulled straw (left), (Cryopette (top right), Rapid-I (right-bottom)); **Fifth row:** JY Straws.

See [Saragusty & Arav, 2011] for more details and references.

#### 4. Equilibrium vs. kinetic vitrification; Evolution of the “Fahy’s” phase diagram

This sub-chapter discusses in detail the phase diagram (“Fahy-Rall” vitrification diagram). We will also discuss using this diagram the two basic and reciprocal ways of achieving VF, which can be done: i) by cooling and warming at relatively moderate rates but very high concentrations of exogenous (and often toxic) vitrification agents/enhancers (VFAs), which is defined as *equilibrium* VF and ii) by increasing the rate of cooling with a few or not at all exogenous VFAs present, which we refer as *kinetic* VF. We will also emphasize that the border of “non-achievable” and “achievable” VF that was once set up by Fahy is arbitrary and largely depends on the currently achievable rates of cooling and warming.

**Fig. 5A** depicts the *original* diagram published by Fahy et al in 1984 [Fahy et al., 1984]. The diagram is divided in 4 distinctive zones. **Zone IV** is the *equilibrium* VF, when it occurs at any practical rates of cooling and warming as it lies to the right of the junction of  $T_m$  (i.e., no ice forming during cooling) and  $T_d$  (no de-vitrification during warming). It is basically the zone where the line E-F on Fig. 1 is drawn but with the notion that  $T_g$  in the Fahy’s diagrams (apparently, for glycerol) lies substantially lower than in Devireddy’s diagram ( $T_g$  of a fully dehydrated sample is well above 0  $^{\circ}\text{C}$  while  $T_g$  of glycerol is in range of -90 $^{\circ}\text{C}$  and below [Pouplin et al., 1999]. For  $T_g$ ’s of some popular vitrificants see Table 1 in [Katkov & Levine, 2004]. **Zone III** is the zone when vitrification occurs. The left border is the junction of  $T_h$  (showed in dotted line as it is hardly to estimate  $T_h$  of very viscous samples) and glass transition curve  $T_g$  and it occurs at concentrated  $C_v$ ’s, the minimal concentrations where *equilibrium* vitrification during cooling occurs at practically any speed. However, such concentration still may produce de-vitrification during re-warming as the devitrification curve  $T_d$  crosses the melting (equilibrium warming) curve at the critical concentration of devitrification  $C_{dv}$ . Thus, this Zone III is the zone where warming must be done fast.

**Zone II**, called by Fahy and colleagues at that time (!) “*doubly unstable*” lies at concentration below  $C_v$ . At those concentrations, both cooling and warming must be done fast to avoid ice formatting and devitrification respectively. That is what we call kinetic vitrification as it deals with the speed of cooling and re-warming rather than with the equilibrium values. It means that the border between that Zone II, where vitrification is achievable with the **Zone I**, where successfully vitrification is impossible at any “reasonable speed” of cooling and warming largely depends on the rate of that cooling and warming: it is reciprocal to the  $C_v$  and  $C_{dv}$  so they move to the left into the area of the lower concentrations.

Thus, **there are 2 basic and reciprocal ways of achieving VF:** i) by raising the concentration, and as result, the viscosity of the intra- and extracellular milieu at relatively moderate and even slow rates of cooling but very high concentrations VFAs,

which is defined as *equilibrium VF* and ii) by increasing the rate of cooling with a few or not at all exogenous VFAs present so deleterious intracellular ice formation is not achieved due to lack of time for growing ice crystal nuclei (*kinetic VF*). Note that the border between “*non-achievable*” and “*achievable*” VF (Zones I and II) that was once set up by Fahy is arbitrary and as we said, largely depends on the currently achievable rates of cooling and warming.

The position of the borders between the zones also depends on the glass transition temperature of the solute ( $T_g$  curve). As we mentioned above, Fahy *et al.* had considered a permeable vitrificant with very low  $T_g$  in range of  $-90^\circ\text{C}$  (glycerol). In the paper on vitrification of sperm that we published in 2003, we hypothesized that  $T_g$  of the intracellular milieu could *be much higher*, so the  $T_g$  of the intracellular exogenous solute would go much above of  $T_g$  of glycerol. We published a review in 2006 [Katkov *et al.*, 2006] (the abstract was presented much earlier in 2003 [Katkov *et al.*, 2003]) with that concept superimposed onto Fahy’s diagram. This concept and an explanation as to why we could vitrify sperm at much less or no exogenous vitrificants at all is shown in **Fig 5B**. We emphasized that the  $T_g$  of a internal vitrificants can go very high, so the border between Zones I and II can be shifted substantially to the left so the successful vitrification (straight blue line) is achievable even the extracellular milieu has no glycerol.

This explanation (and at lesser extent the experimental data published at that time *per se*) had been dismissed both by Fahy and by other prominent cryobiologists, most notable of them would be Stan Leibo. They either called it “*quasi-vitrification*” or ignored that such work was published (due to the fact that it was not referred at PubMed, even though the leading author had distributed its copies among numerous scientists in the field). The striking example is the Fahy’s chapter [Fahy & Rall, 2007] where he spent a great deal of time bashing kinetic vitrification, giving intricate details as to how its first scientists had failed lately to implement K-VF in practice. In regards to our work, he simply ignored that paper even existed, even though it had been sent it to him and we discussed it with him [Dr. Fahy] in meetings.

So, the “*contemporary vitrificators*” ignored mentioning the paper and notion of kinetic vitrification at very low concentration of the extracellular solute. That however, did not mean they had not learned or gained from it. Neither could they ignore the booming success of K-VF in the assisted reproduction field, which we mentioned above. The whole set of innovation was aimed to cool and warm cells faster, which allowed the ART practitioners to move away from the humongous concentrations of DMSO, EG, PG or glycerol, which would be necessary for equilibrium VF. So, that was actually reflected in the very same chapter published in 2007 [Fahy & Rall, 2007] as it presented a Fahy’s diagram with some interesting and *key changes* in comparison to the publication in year 1984 (**Fig. 5C**). We deliberately superimposed those changes on the original Fahy’s diagram [Fahy *et al.*, 1984].

First, the words “*doubly unstable*” have been eliminated and it made sense because 99% of publications on vitrification of oocytes and embryos have been done at concentrations that exactly represented the “*doubly unstable*” Zone. That would not make all people who have successfully and *stably* frozen their precious happy to realize that they actually worked in the “*double instability*” zone (and which *is not correct* anyway: the vitrified cells *are stable* at temperatures below of their glass transition, i.e., well below the  $\text{LN}_2$  temperature).



Secondly, the authors of the chapter shifted the border between “achievable” and “non-achievable” vitrification (Zones I and II) to the left. It was a small concession to the reality, people have been successfully vitrifying oocytes and other “watery” cells with substantially less concentrations than 40%, but yet it reflects the general “drift to the left”, so to speak.

Most importantly in our opinion is that the notorious “killing darts”, which marked the “unsuccessful vitrification” in the Zone I on the original Fahy’s diagram in 1984... suddenly disappeared in a newer version. It means that the authors allowed (at least theoretically) the

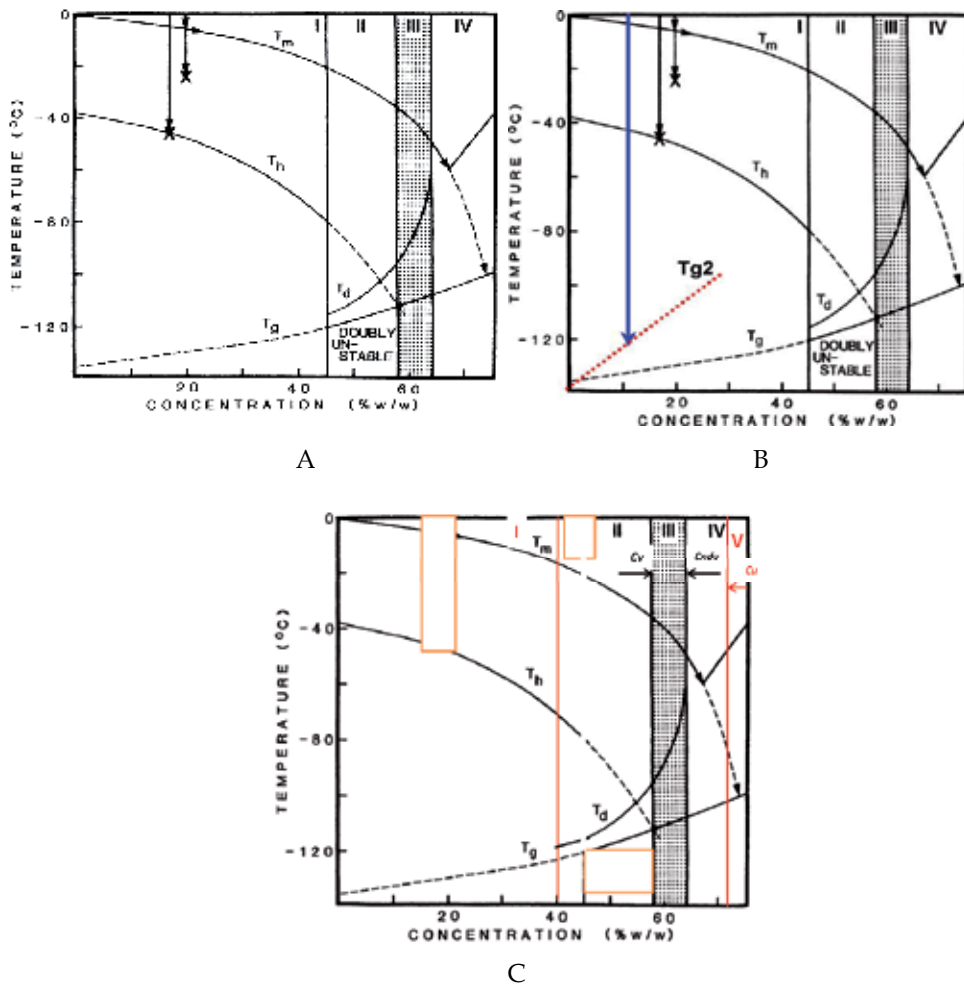

Fig. 5. **A (top)**: original diagram published Fahy et al. in 1984 [Fahy et al., 1984]. The diagram is divided in 4 distinctive zones. **Zone IV** is the *equilibrium VF*, when it occurs at any practical rates of cooling and warming as it lies to the right of the junction of  $T_m$  (i.e., no ice forming during cooling) and  $T_d$  (no de-vitrification during warming) it is basically the zone

when the line **E-F** on **Fig. 1** is drawn but with the notion that  $T_g$  in the Fahy's diagrams (apparently, for glycerol) lies substantially lower than in Devireddy's diagram ( $T_g$  of fully anhydrated sample is well above  $0^\circ\text{C}$  while for glycerol  $T_g$  depicted on this diagram is in range of  $-90^\circ\text{C}$  and below [Pouplin *et al.*, 1999]). For  $T_g$ 's of other popular vitrificants see Table 1 in [Katkov & Levine, 2004]. **Zone I** is the zone of "non-achievable" VF, **Zone II** is *kinetic* VF marked as "doubly unstable", and **Zone III** is an intermediate zone where devitrification must be avoided while VF is achievable at slow rates. Note two "killing darts" in Zone I that indicate ice crystallization (vitrification is not achieved).

**B (middle)**: Fahy's diagram supplemented by us in 2006 [Katkov *et al.*, 2006] with the notion that the border between Zones I (unsuccessful VF) and II (successful *kinetic* VF) in diagram **A** is arbitrary and can be moved far left to the area of very low concentrations of external VFA's (or no VFA not at all as in case of human sperm). The blue line indicates successful *kinetic* VF, it is analogous with the **G-H** line on **Fig. 1**.

**C (bottom)**: Fahy's diagram, version 2007 depicted in [Fahy & Rall, 2007] but superimposed by us on the original diagram **A**. Note the following notable changes: i) "disappearance of words "doubly instable"; ii) shifting the border between zones I and II to the left; iii) disappearance of the "killing darts" in Zone I; in addition of **Zone V** (E-VF achievable even with a introduction of exogenous ice: propagation of the ice is stopped). See the major text for further explanation.

blasphemous idea that vitrification could occur at *any* concentration of the solute, however low it might be. And it is true, even the pure water can also be vitrified, though the rate of vitrification must be in range of tens to hundreds of millions  $^\circ\text{C}/\text{min}$  [Angell, 2004]. We can only speculate where all those Zones would go in *that* case. Apparently, they would all disappear! Finally, Fahy and Rall made two crucial concessions in their text (probably, insisted by Bill Rall taking to the account his vast experience and knowledge of the ART field), which we cite below in full:

- "For the small samples often used in reproductive cryobiology, it becomes important that  $T_h$ ,  $T_g$ , and  $T_a$  are all rate dependent (i.e.,  $T_h$  will go down,  $T_g$  will go up, and  $T_a$  will go up as the rate of change of temperature increases) because extremely high cooling and warming rates are feasible."
- "However, Figure 1A.5 [depicts relationships between the critical cooling rate of vitrification and concentration of the vitrificant, I.I.K.] is based on pure permeating cryoprotectants in water and does not take into account the effects of the carrier solution (see below) or additives such as serum or sucrose, nor does it take into account the effect of concentrated intracellular protein in shrunken cells or the naturally low water content of cells like spermatozoa" [of course, no mentioning of our work whatsoever!]

Those two citations exactly explain how *kinetic* vitrification works without even mentioning it! While we are quite accustomed to the that style of ignoring "inconvenient" publications from several prominent cryobiologists and pushing their explanation aside the facts that "adjusted" (with the reality) Fahy's curve together with the two statements above clearly indicate that even as the staunchest orthodox proponents of equilibrium ("right") vitrification as Dr. Fahy could not ignore the facts and explanation why and how the *kinetic* one is working and dominating the scene now. Apparently and evidently they learned from our publication, as well as from the publications of others.

There are other peculiar similarities between that chapter and some of our *earlier* papers, such as use of the equation for determination of the viscosity of the solute near  $T_g$  [Katkov & Levine, 2004] and storage below and above  $T_g$  of the sample [Katkov *et al.*, 2006]; we would encourage our readers to compare our work and the Fahy's review with the notion that WLF relationship for viscosity near  $T_g$  in our work is substituted by an equivalent VTF equation in the Fahy's chapter (see **Appendix 1**).

**In conclusion**, of these sub-chapters, it is evident that the *kinetic* way dominates the present art of vitrification and all efforts are moving to the direction of increasing speeds and decreasing concentrations (see "*Race for The Pace*" below). On the other hand, the future of *equilibrium* vitrification even in the field where it cannot be substituted by K-VF such as organ CP (but can be done with precision SF as described in a Chapter by Butler and Pegg in this Book [Butler & Pegg, 2012]), remains largely unclear.

## **7. Kinetic vitrification of sperm: why some species have while others have not been vitrified?**

Now, as we are fully equipped to discuss the core topic of the Chapter, let us refresh the turn of (relatively) recent events related to the *kinetic* VF of spermatozoa.

### **7.1 A turn of the helix: The Isachenkos' experiments on vitrification of human sperm**

As we mentioned in the Introductory sub-chapter, 1, after earlier attempts to vitrify sperm with contradictory results, the findings of the cryoprotective role of glycerol and other CPAs at slow freezing moved the field of cryopreservation of spermatozoa from early attempts of K-VF toward E-SF. It has been successfully applied to many types of sperm, yet somewhere in 1990s, the data started accumulating that suggested that glycerol, DMSO and other permeable CPAs might adversely affect the genetic and especially epigenetic fabric of spermatozoa. At the same time, several Japanese groups had successful CP of very sensitive mouse spermatozoa without any permeable CPA but with 18% of impermeable raffinose (a 3-ring sugar) and a mixture of proteins (skim milk) [Okuyama *et al.*, 1990; Tada *et al.*, 1990; Yokoyama *et al.*, 1990]. It worked so exceptionally well, that the Mazur's group, which had originally cryopreserved mouse sperm with glycerol [Mazur *et al.*, 2000] (though found that it can be indeed chemically toxic to the sperm [Katkov *et al.*, 1998]) finally also reported that fast immersion of mouse spermatozoa into liquid nitrogen without any CPA worked perfectly [Koshimoto *et al.*, 2000]. In any case, those data had inspired Evgenia and Vladimir Isachenko to freeze human sperm in tiny pellicles by plunging those "cryogenic loops" without any CPA whatsoever. They published their findings in 2002, and a year later, the explanation why it worked was followed [Isachenko *et al.*, 2003; Nawroth *et al.*, 2002]. That marked the "*second wind*" in the kinetic VF of spermatozoa. The history of the development is described in numerous papers [Isachenko *et al.*, 2004a; Isachenko *et al.*, 2008; Isachenko *et al.*, 2004b; Isachenko *et al.*, 2005] and several reviews by the authors [Isachenko *et al.*, 2007; Isachenko *et al.*, 2010; Katkov *et al.*, 2007] and briefly touched in this Book in Chapter 2 [Isachenko *et al.*, 2012]. The method has been involved from a cryo loop (pellicle) through droplets in LN<sub>2</sub> to quite elaborated "aseptic technology". Some of the carriers used by the Isachenkos at different stages are shown in **Fig. 6**.

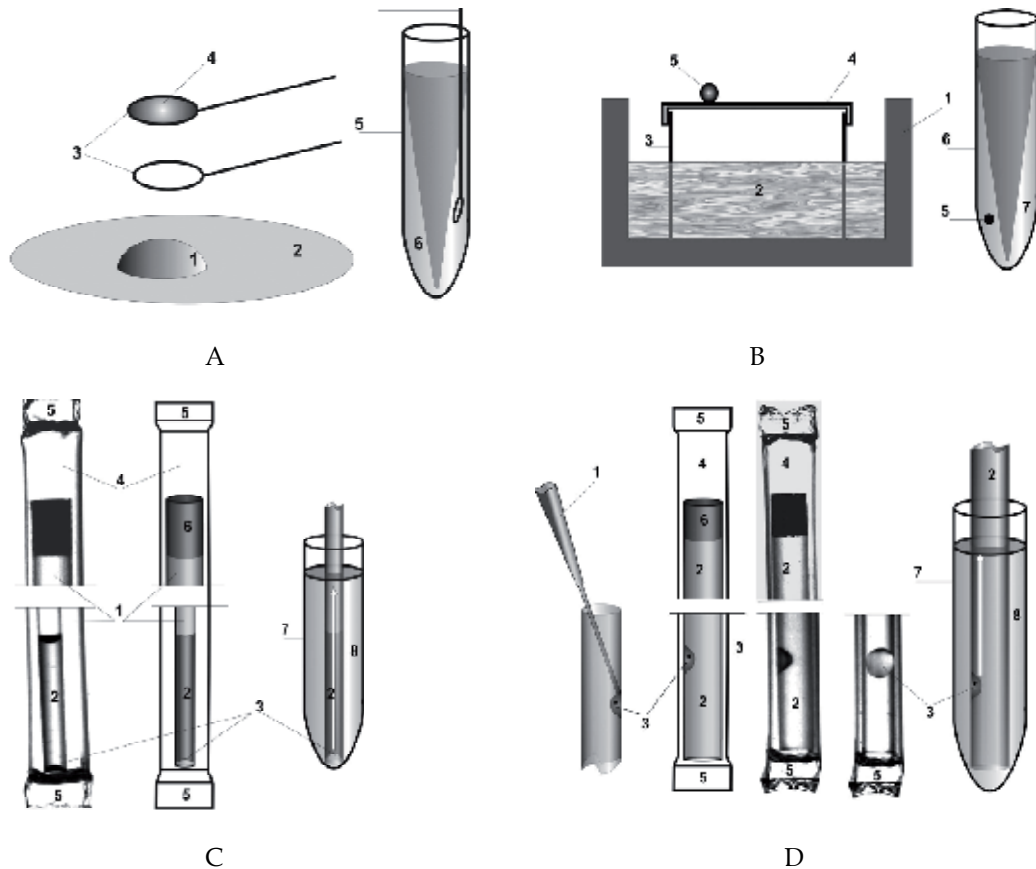

Fig. 6. Different techniques for kinetic vitrification of human sperm developed by the Isachenkos and colleagues: A: copper or nylon cryo loop (pellicle); B: a modification of a droplet technique; C; open-pulled straw; D; straw-in-straw. See [Isachenko *et al.*, 2007] for details.

The method and the scientist themselves were first dismissed, then ignored, then ... ignored again. **Table 1** represents just two examples when the Isachenkos published their paper, and other cryobiologists, who came to the same conclusions, namely:

- There is no proof of the *absence* of vitrification inside the sperm even at quite slow cooling [Morris, 2006]; the role of intracellular ice in the death of fast cooling mouse sperm is also questioned in [Mazur & Koshimoto, 2002].
- Some cells can be vitrified in "*diluted*" solutions at relatively slow rate of cooling but very fast warming is essential for kinetic VF [Mazur & Seki, 2011]

Thus, both cryobiologists have reported similar findings as the Isachenkos observations, but they unfortunately fell short of mentioning Isachenkos in their own publications and presentations (e.g., in Cryo-2010 in Bristol), which might have made looking their observations (that were solid, of course) for an unfamiliar reader as "pioneering" or even as "*a new paradigm for cryopreservation by vitrification*" [Mazur & Seki, 2011]. The argument "*that paper by the Isachenkos et al. was not citable because the effect of the warming rates was not*

<p><b>V. &amp; E. Isachenkos and I.I. Katkov:</b> Factors that may enhance intracellular vitrification of human sperm: <i>...Cells naturally contain high concentrations of proteins, which help in vitrification... this would enhance both the viscosity and Tg of the intracellular cytosol of spermatozoa . [Isachenko et al., 2003].</i></p>	<p><b>John Morris:</b> - <i>"It is generally assumed that the intracellular environment of sperm has a low water content coupled with high protein levels. These data demonstrates that it heterogeneous nucleation sites are absent in that intracellular vitrification can occur:" (CRYO-2010).</i> - <b>"We demonstrate</b> that the high intracellular protein content together with the osmotic shrinkage associated with extracellular ice formation leads to intracellular vitrification of spermatozoa during cooling" (Morris et al, 2011, <i>Cryobiology</i>, <b>64</b>:71-80). - <i>"The results described in this article suggest that it is now appropriate for new models to be developed that exclude the formation of intracellular ice" [Morris, 2006].</i></p>
<p><b>V. &amp; E. Isachenkos and I.I. Katkov:</b> Crucial role of fast warming <i>... As a result, we can speculate that we were able to achieve intracellular vitrification of the human spermatozoa even at such a low range cooling rate. ... However, as we discuss below, our method of instant thawing seemed to prevent cell damage even after relative slow freezing in liquid nitrogen vapor. [Isachenko et al., 2004b]</i></p>	<p><b>Peter Mazur and Shinsuke Seki:</b> <i>WARMING rate is much more critical in "diluted" vitrification solutions than the cooling rate (CRYO-2010), [Mazur &amp; Seki, 2011]</i></p>

Table 1. Comparison of statements published by Isachenkos et al in 2003-4 and by other scientists reported in 2010 on Cryo-2010 in Bristol, UK and other publications.

*thoroughly investigated"* makes sense in the matter of describing a particular technique/ protocol but it does not hold water when the claim of a *"new paradigm"* in vitrification was put on the table seven years after the Isachenkos' paper, with essentially the same claim that had been published [Isachenko *et al.*, 2004b]. That new paradigm was indeed established but it was done in 2002-4, not in 2010-11!

Note that the role of ultrafast warming during kinetic vitrification had been known at some extend before so neither of the authors (the Isachenkos or Mazur & Seiko) can claim the absolute priority. In case with the crucial role of endogenous proteins and other high molecular weight components for the intracellular *kinetic* vitrification of spermatozoa, Katkov and colleagues clearly presented this idea (and indirect proof of it) in 2003. Therefore, any attempts to completely ignore that fact by Morris and colleagues and to position themselves as *"pioneers"* of this idea much later can be considered as blunt plagiarism.

## 7.2 Kinetic vitrification of sperm of *other* vertebrates: history of success and stories of failure

As we have mentioned, kinetic VF of human sperm in all its varieties shown on Fig. 6 seemed to be working equally well; however, when we tried the “droplet method” described in [Isachenko *et al.*, 2008] (20  $\mu$ L droplets of swam-up washed sperm supplemented by 0.25 M sucrose) on model animals (rodent spermatozoa, the results (Figs. 7) were not so pronounced. So, while it worked well for human sperm, the droplet kinetic VF did not work so well for mouse sperm, and it worked poorly (at a much lower survival rate than conventional slow freezing) on rat sperm. Note that both rats and mice sperm have larger and apparently more watery heads.

But still, the Isachenkos’ method worked in general so Celltronix and Kharkov Zoo launched 2 field expeditions (with the participation of a Moscow Zoo’s specialist) for freezing polar bear (*Ursus maritimus*) sperm (in a distant Russian zoo) and sperm of gyrfalcons (*Falco rusticolus*), golden eagles (*Aquila chrysaetos*) and Eastern imperial eagles (*Aquila heliaca*) in the Russian Raptor Breeding Center Galichya Gora near Voronezh.

For the polar bear, for which sperm, to our knowledge, had not been frozen yet, the basic slow protocol developed for spectacled bear (*Tremarctos ornatus*) [Erokhin *et al.*, 2007] was used. That protocol worked quite poorly, vitrification protocol was even worse.

For the all 3 raptor species, gyrfalcon, the golden and the imperial eagles, slow freezing (using the slow freezing protocol in [Blanco *et al.*, 2000]) worked very poorly in our hands despite the fact that artificial insemination with fresh sperm is a routine and successful procedure in that Center. And finally, kinetic vitrification using the Isachenko’s “droplet” method failed completely.

After several sleepless nights of thinking what went wrong besides our insufficient experience with freezing the raptor sperm (my counterpart had frozen crane sperm before), difficulties related to small volume and a lot of fecal particles and urine in sperm, I.I. Katkov realized that the sperm of those species was fundamentally different in geometry from that of human sperm: their heads were much larger, and they looked much more watery, less condensed than the compact human portions. The rodent sperm heads were also relatively large, but those species, where we failed, the heads apparently contained much more water and presumably less so called “inactive osmotic volume”, which means the concentration of internal proteins, sugars, nucleotides and other “internal endogenous vitrificants” was much lower in the polar bear spermatozoa, and especially in the sperm of the raptors. And according to the thermodynamic of the glassy state, as lower concentration of vitrificants the faster you need to cool the cells. From the personal communication with the Isachenkos several years before, it was known that kinetic vitrification of oocytes and embryos without cryoprotectants had been failed completely even with the smallest drops. And those cells have the ratio internal vitrificants: water about 7-9 lower than in human sperm as its osmotically active volume (i.e. water per se) is about 75%, while in human sperm it is only 25%. That meant that we just did not have sufficient cooling speed to vitrify those species!! That crystallized the hypothesis that if we would cool it fast enough, faster than the critical rates of cooling and warming for the most watery cells, we can vitrify all cells with the same protocol. That is how the concept of the Universal Cryopreservation Protocol was born (published first in the “Embryomail” in the spring of 2010).

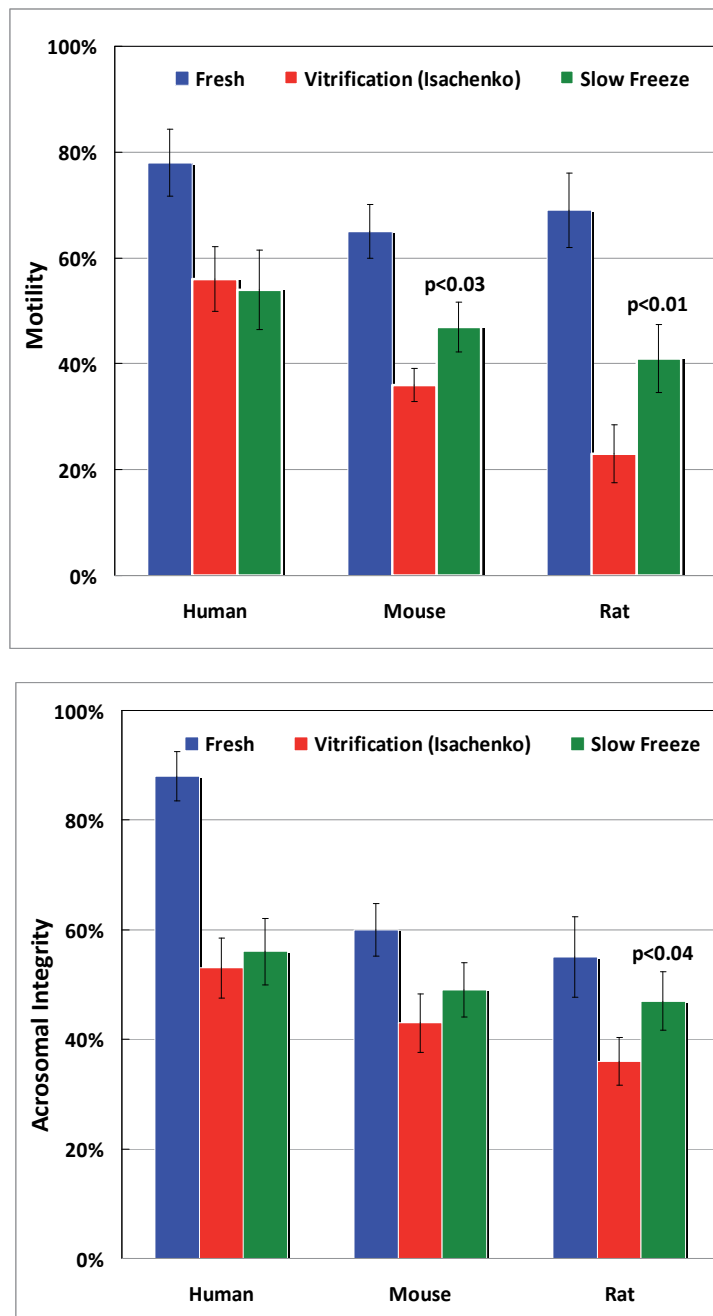

Fig. 7. Progressive motility (left) and acrosomal integrity (right) of 3 species of sperm frozen by conventional slow-freezing protocols in the media customized for different species (green) and by an identical protocol of vitrification [Isachenko et al., 2008] by quenching droplets in PBS containing 20% human serum albumin (HSA) and 0.25 M sucrose (red) directly into LN<sub>2</sub>. Two methods of cryopreservation are compared.

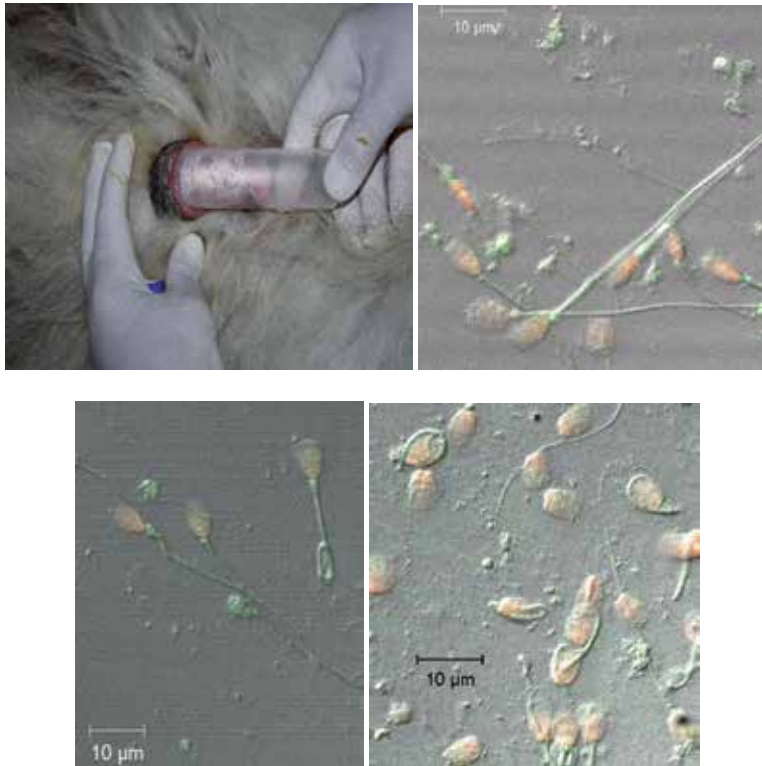

Fig. 8A. An attempt to vitrify sperm of the polar bear, **from left to right**: sperm retrieval; fresh; slow frozen; and vitrified sperm. Slow frozen sperm protocol worked poorly, *kinetic VF failed*.

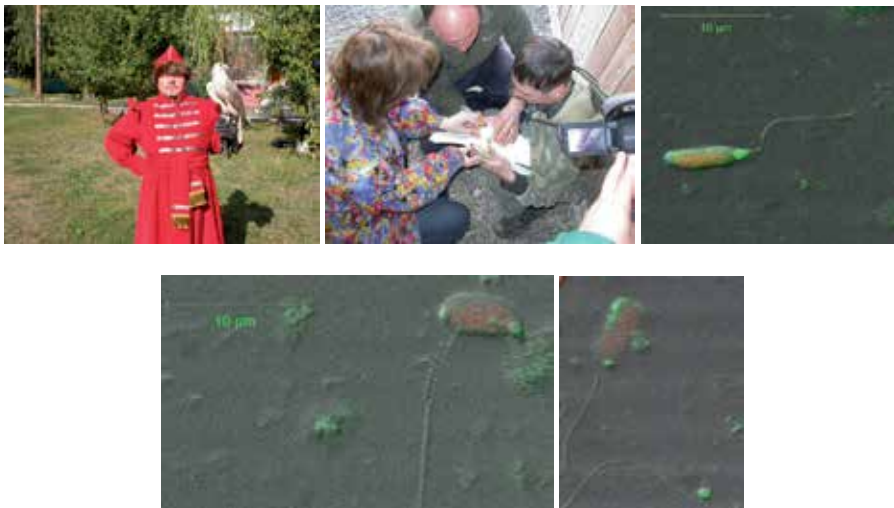

Fig. 8B. An attempt to vitrify sperm of the gyrfalcon, **from left to right**: I.I.K. with the bird; sperm retrieval process; fresh; slow frozen; and vitrified sperm. Slow frozen sperm protocol worked poorly, *kinetic VF failed*.



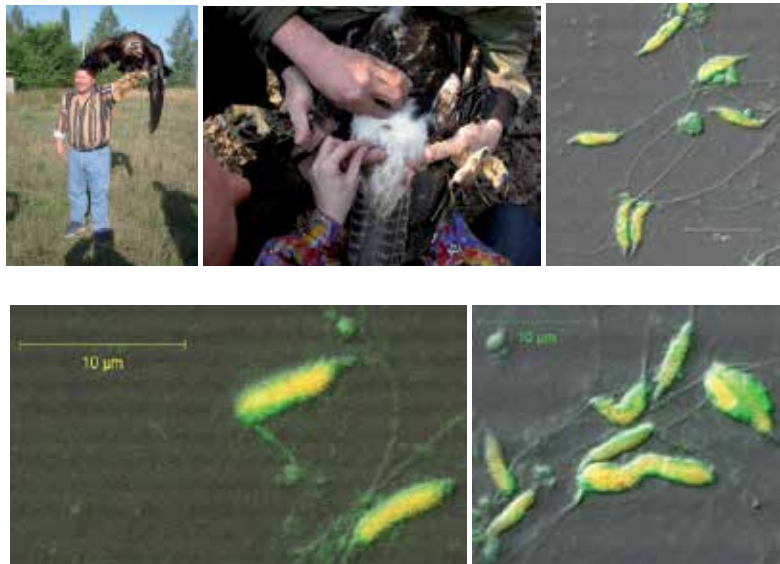

Fig. 8C. An attempt to vitrify sperm of the golden eagle, **from left to right**: I.I.K. with the bird; sperm retrieval process; fresh; slow frozen; and vitrified sperm. Slow frozen sperm protocol worked poorly, *kinetic VF failed*.

### 8. Conclusion: “Race for the Pace”: Is the universal cryo-protocol possible?

The universal cryoprotocol, that would fit *all* types of cells, at least if they are in suspension on make a thin layer, would be the *Holy Grail* of cryobiology. Here is our hypothesis for consideration [Katkov, 2010]:

1. Every cell has its own critical rates of cooling and thawing, at which and higher the cell can be vitrified during cooling ( $B_{cr\_cool}$ ) and will not devitrify during warming ( $B_{cr\_warm}$ ) *without* any external "cryoprotectants" (they must be called "vitrificants" in this case). Or it might be just that non-lethal ice (i.e. cubical vs. hexagonal "killer ice") is formed during cooling and its transformation (recrystallization) to hexagonal type is precluded during warming. In any case, at rates higher than those two  $B_{cr}$ 's, the cell will survive without any exogenous compounds.
2. Those rates are substantially *lower* than predicted by the contemporary theories (Fahy and Rall, Boutron's work, Cravalho 's school: Toner, Karlsson, *et al*). We will not go into the details of the thermodynamics of the glassy state but the three main reasons are: i) presence of the internal cell vitrificants with high  $T_g$ ; ii) small compartmentalized intracellular milieu; iii) no "true" extracellular VF is needed for survival as the cell has no time and shrink at such fast time. In any scenario, the cell *survives* if the pace of cooling and warming is higher than those two  $B_{cr}$ 's, and that is what matters.
3. The distribution and average values of those  $B_{cr}$ 's 's depend on the species of cells, particularly on the abundance of endogenous vitrificants, how "watery" those cells are, the level of compartmentalization, the size of the compartments, etc. It may well be that the same species (such embryos) might have *very* different  $B_{cr}$ 's at different stages of their development.

4. We predict that while those speeds are relatively high for the majority of cell species (in range 200,00-1,000,000 °C/min), we have already achieved those critical rates in one well-documented case, namely humans as well as some other species of vertebrate sperm, thanks to the early work in the 1930s and by the Isachenkos in this century.
5. We believe that those high speeds are achievable for *all* species but that needs entirely new cryogenic equipment. Such rates if they are high enough to surpass the highest  $B_{cr}$ 's would be *universally* applicable to *any* type of suspensial and single cells so we will be witnessing the "Race for the Pace" very soon, some groups have been already actively working on it now.

Thermodynamic analysis of the most recent attempts of creating novel systems for kinetic VF such as cryogenic oscillating heat pipes [Jiao et al., 2006; Jiao et al., 2009], nano-droplets [Demirci & Montsesano, 2007], quartz capillaries [Risco et al., 2007], and some others approaches that claim "*ultra-fast*" rates (see a comprehensive review by Criado in this Book), which in our opinion, do not produce the rates fast enough to reach the majority of  $B_{cr}$ 's without using exogenous permeable (and thus, potentially toxic) vitrificants. Thermodynamical considerations that prove this statement are not in the scope of this Chapter and will be done elsewhere. In fact, the *hyper-fast* rates of cooling and warming will be needed, and there is about of an order or two of magnitude difference between "*ultra-*" and "*hyper-*" (cf. *ultrasonic* and *supersonic* speed of flight as an example).

Introduction of such a "*Universal Kinetic Vitrification Protocol*" applicable for *all* cells (at least for those that are in suspension or make a thin attached layer) would shift the whole paradigm in cryopreservation of germplasm (and other types of suspensial cells) and in cryobiology as a science. It will require both new equipment for realization of hyper-fast rates (on which we are working now) and new methods of measurements. For example, it is not clear how  $T_h$ ,  $T_m$ , and  $T_d$  curves on the Fahy diagram would behave at speeds of cooling and warming in order of thousands °C/min, and how that could be measured: they may disappear completely! In any case, it will open not only the possibility of development of a uniform protocol and equipment for all existing and (which especially important) *new* types of cells and species, but it will also bring new, very challenging but exciting horizons for basic cryobiology as well.

### Epilogue: "*In Defence of the Genius*" (Editor's Reflection)

*"In Defense of the Genius"*

Dr. Gregory Fahy called in his Chapter #1A [Fahy & Rall, 2007] the Luyet method and his promotion of kinetic VF as "*Luyet's tyranny*" so my choice of words in this Chapter is just as a "*symmetrical response*" to that stye, nothing personal is intended. Greg spent a great deal of time in that and other numerous reviews and lectures describing the Luyet's unsuccessful attempts to implement K-VF in late 1930s -beginning of 1950's. However, we have not spent so much time in *this* Chapter on describing the *failure* to realize the promised potential of equilibrium VF and ice blockers for organ vitrification since 1984, even though Dr. Fahy and his colleagues have had in order of magnitude more resources, knowledge, and time than that of Father Luyet had had in 1939-1954. We would call this situation as being "*stuck in the rut*" and "*the promise is not fulfilled*".

At the same time, we completely agree with a statement that Fahy and Rall made in a sub-chapter titled "*The ghost of Luyet*":

*“Here we can only note the irony that, having been launched by breaking free of Luyet’s tyranny of ultrarapid cooling, vitrification methods have now essentially turned back closer to Luyet’s original idea of cooling as quickly as possible with minimal intracellular exposure to cryoprotectants [i.e., kinetic vitrification VF, I.I. K.], albeit this time using at least marginally adequate concentrations of intracellular solutes. The ghost of Luyet lives on in the form of this ongoing methodological evolution, and we think he would have been pleased to see how his ideas about vitrification ultimately related to the now widespread use of vitrification as a practical and successful method of cryopreservation long after he, himself, had abandoned this approach.”*[Fahy & Rall, 2007]

As a cryobiologist, who has been working in the same field, the Editor (at the Eves of 2012) might announce the following “resolutions”:

- I wish cryonics would have been a *real* science;
  - I wish ice-blockers would have been *worked* for the human body ;
  - I wish cryonics would have *preserve* not only the “ghost” (we, actually, preserve SPIRIT of his science), but his body as well;
  - I wish he could have been vitrified successfully in 1974 and re-warmed alive in 2012.
- Had that all happened, Father Luyet would have been indeed thrilled to see how his method has been spread and are opening new horizons!

And for me, it is better to live under “tyranny” of the genius than under “ochlocracy” of the ignorant or “democracy” of the arrogant, and seeing as Wikipedia and other internet resources have been invaded (and infested) by cryonics “experts”, and are full of their biographies, cryonic companies’ descriptions, etc, while a reader can find neither biographies of Father Lyuet nor other prominent cryobiologists, both who passed away and live and in good health today. Unfortunately, Wikipedia has failed to be fair and balanced on this matter, but hope it’ll change with time.

But that would be a topic of our other story, here we must stop and say just only that: kinetic vitrification of sperm, the early child of Father Luyett and the other *pioneers of the cryobiological frontiers*, is very much alive and on the march! And our own success and failures, honestly described in this Chapter, have only strengthened the position K-VF as a viable (not marginal!) and very promising method of cryopreservation.

### **Appendix 1. Some peculiar similarities between [Fahy & Rall, 2007] and our earlier papers, which are not cited there**

We invite the readers to compare the physical description of vitrification in that chapter by Fahy and Rall, particularly sub-chapter *“The kinetic basis of vitrification”*, and the first part of the *“Optimal storage below T<sub>g</sub>”* with our preceding publications (pp. 71 and 75 in [Katkov & Levine, 2004] and pp. 353-4 “6. Storage at temperatures higher than T<sub>g</sub> of water” in [Katkov et al., 2006] respectively). The only substantial difference is that *“the most widely used”* WLF equation (25) in our paper [Katkov & Levine, 2004].

$$\eta(T) = \eta(T_g) 10^{\frac{-C_1(T-T_g)}{C_2+(T-T_g)}} \equiv \eta(T_g) e^{\frac{-2.303C_1(T-T_g)}{C_2+(T-T_g)}} \quad (1)$$

is replaced by the VTF equation in [Fahy & Rall, 2007] as following:

$$\eta(T) = \eta(T_g) e^{\frac{B}{T-T_v}} , \quad (2)$$

where  $\eta(T)$  is the viscosity at temperature  $T$  above the glass transition temperature  $T_g$ ,  $\eta(T_g)$  is the viscosity at the glass transition temperature,  $T_v$  is the “Vogel temperature” [Zhai & Salomon, 2011] and  $C_1$ ,  $C_2$  and  $B$  are empirical constants.

If the assumption of a linear relationship between the fractional free volume and temperature holds (free volume theory for WLF), VTF equation can be transformed into the WLF equation so the equations (1) and (2) must be combined as an equality, i.e.:

$$\frac{-2.303C_1(T - T_g)}{C_2 + (T - T_g)} \equiv \frac{B}{T - T_v}, \quad (3)$$

which is true at *any*  $T$  and  $T_g$  in the range of being considered. Equalizing the numerators and denominators separately, the relationships between the WLF and VTF constants can be found as following:

$$C_1 \equiv \frac{B}{2.303(T_g - T_v)} \quad (4)$$

$$C_2 \equiv T_g - T_v, \quad (5)$$

which coincides with [Zhai & Salomon, 2011].

Beside this substitution of WLF with VTF, which accordingly to [Zhai & Salomon, 2011] “*has a more profound physical meaning that relates both thermodynamic and kinetic concepts*”, there are definite similarities between [Fahy & Rall, 2007] and [Katkov & Levine, 2004; Katkov *et al.*, 2006], which of course might be purely accidental (with a notion that those two papers had been sent to G.F. by I.I.K. well before 2007), so we will follow the spirit of the Open Access, namely “*Let's the readers to decide*”.

## Appendix 2. On the recent paper by the Isachenkos on “*vitrification in large volumes*”

Recently, the Isachenkos group published a report on vitrification of 500  $\mu\text{L}$  of human sperm vitrified with 0.25 M sucrose. Recently, the Isachenkos group published a report on vitrification of 500  $\mu\text{L}$  of human sperm vitrified with 0.25 M sucrose [Isachenko *et al.*, 2011]. Unfortunately, our two other teams that have co-authored this Chapter were not able to repeat the method: both human and bovine spermatozoa sperm survived very poorly (single alive spermatozoa were observed) after vitrification in 0.5 mL straws. Interestingly enough, morphology of the sperm was practically intact (**Fig. 9**). This, together with the failure of the method even for 25  $\mu\text{L}$  droplets (another Isachenkos modification) to vitrify spermatozoa of polar bear and 4 raptor bird species described in the major text of this Chapter, indicates that the Isachenko method of “*cryoprotectant*”-free cryopreservation works satisfactory for some species of sperm [Merino *et al.*, 2011a; Merino *et al.*, 2011b; Sanchez *et al.*, 2011] but not for the others, and it is completely inapplicable to big and watery oocytes and embryos. And without further clarification, the method of kinetic VF in “*large volumes*” have not been able to be repeated independently even for human and bovine sperm. Some of the questions that have been raised from other co-authors of the present Chapter in regards to that paper are:

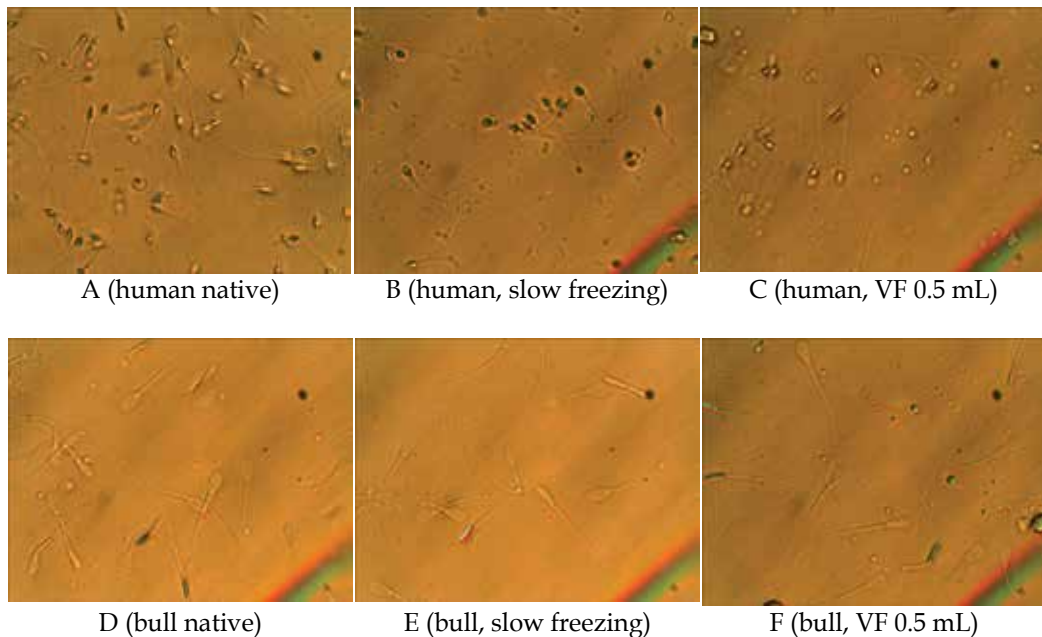

Fig. 9. Attempts to vitrify human (A-C) and bovine (D-F) spermatozoa using “large volume” (500  $\mu$ L) method [Isachenko *et al.*, 2011]

A and D – native sperm, B and E spermatozoa frozen slowly with glycerol, C and F- sperm vitrified accordingly the Isachenko protocol.

Approximately 50% of human and bull sperm survived slow freezing,. The vitrified cells are not visibly damaged but no motile spermatozoa were observed for both species

- Sucrose is considered as “natural” CPA while glycerol is not. See examples given in [Fahy & Rall, 2007] about Alaskan beetles than can cumulate 10 Mole/L of glycerol!
- Glycerol cannot “dilute” intracellular osmolites - it can only add additional osmotic pressure inside the cell, thus, preventing more extensive shrinkage during slow freezing; that is exactly how it works as the CPA (not to be confused with its role in VF). Apparently, the authors confused it with the glycerol action as a plasticizer of the intracellular milieu, thus, lowering its  $T_g$  inside the cells, but this is a completely different topic.
- Sucrose per se, as an impermeable solute, cannot directly penetrate internal organelles such as mitochondria; the role of sucrose, apparently, is to dehydrate the cells and make intracellular vitrification easier using lower cooling and warming rates. That in theory would allow us to vitrify larger volumes.
- It is not clear whether “It is known that human spermatozoa contain large amounts of proteins, sugars, and other components that make the intracellular matrix highly viscous and compartmentalized and may act as natural cryoprotectants” for the authors (the idea had been originated from the paper published in 2003 [Isachenko *et al.*, 2003] but that that source is NOT referred) or it is a “common knowledge” (as the explanation of the

possibility of kinetic VF of sperm) that had been recognized for many year prior to that publication in 2003. Note that the authors confused vitrificants with CPAs: intracellular proteins do not help slow freezing.

- Pre-cooling of the vitrified group is not detailed and it is not clear whether that grouped was pre-cooled at all.

Thus, there is a disparity in experimental verification of the method between several groups that have been contributed to this Chapter, which we feel should be clarified.

## 10. References

- Angell C. A. (2004). "Amorphous water." *Annu Rev Phys Chem* 55: 559-83.
- Beier A. F., Schulz J. C., Dörr D., Katsen-Globa A., Sachinidis A., Hescheler J. & Zimmermann H. (2011). "Effective surface-based cryopreservation of human embryonic stem cells by vitrification." *Cryobiology* 63: 175-85.
- Bernstein A. D. & Petropavlovski V. V. (1937). "[Influence of non-electrolytes on viability of spermatozoa]." *Buletin' Eksperimentalnoi Biologii i Medicini (Rus.)* III(4225): 21-25.
- Blanco J. M., George Gee G., Wildt D. E. & Donoghue A. M. (2000). "Species Variation in Osmotic, Cryoprotectant, and Cooling Rate Tolerance in Poultry, Eagle, and Peregrine Falcon Spermatozoa." *Biol Reprod* 63: 1164-1171.
- Butler S. & Pegg D. (2012). Precision in cryopreservation - equipment and control. In: *Cryopreservation / Book 1 (ISBN 979-953-307-300-1)*. Eds: I. I. Katkov, InTech. 1: *in press*.
- Chakraborty N., Chang A., Elmoazzen H., Menze M. A., Hand S. C. & Toner M. (2011). "A Spin-Drying Technique for Lyopreservation of Mammalian Cells." *Ann Biomed Eng* 39: 1582-1591.
- Cipri K., Lopez E. & Naso V. (2010). "Investigation of the use of Pulse Tube in cell cryopreservation systems." *Cryobiology* 61: 225-30.
- Demirci U. & Montsesano G. (2007). "Cell encapsulating droplet vitrification." *Lab Chip* 7: 1428-1433.
- Devireddy R. & Thirumala S. (2011). "Preservation protocols for human adipose tissue-derived adult stem cells." *Methods Mol Biol* 702: 369-394.
- Erokhin A. S., Shishova N. V. & Maksudov G. Y. (2007). "[A comparison of two diluents for the cryopreservation of ejaculated spermatozoa in spectacled bear (*Tremarctos ornatus*)]." [Reproduction in Domestic Animals] *Rus.* 42: 95-96.
- Fahy G. M., MacFarlane D. R., Angell C. A. & Meryman H. T. (1984). "Vitrification as an approach to cryopreservation." *Cryobiology* 21(4): 407-26.
- Fahy G. M. & Rall W. F. (2007). Vitrification: an overview. In: *Vitrification in Assisted Reproduction: A User's Manual and Troubleshooting Guide*. Eds: M. J. Tucker and J. Liebermann. London, UK, Infroma Healthcare. Ch.1A: 1-20.
- Fahy G. M., Wowk B., R. P., Chang A., Phan J., Thomson B. & Phan L. (2009). "Physical and biological aspects of renal vitrification." *Organogenesis* 5(165-175).
- Foote R. H. (2002). "The history of artificial insemination: Selected notes and notables." *J Anim Sci* 80(E-Suppl. 2): E1-E10.
- Gilmore J. A., Liu J., Gao D. Y. & Critser J. K. (1997). "Determination of optimal cryoprotectants and procedures for their addition and removal from human spermatozoa." *Hum Reprod* 12(1): 112-8.

- Gordts S., Roziers P., Campo R. & Noto V. (1990). "Survival and pregnancy outcome after ultrarapid freezing of human embryos." *Fertil Steril* 53(3): 469-72.
- Graevsky E. Y. (1948a). "[Living matter and low temperatures]." *Priroda* (Rus.) 5: 13-25.
- Graevsky E. Y. (1948b). "[Glassy state of protoplasm in conditions of deep cooling]." *Uspehi Sovr. Biol.* (Rus.) 14: 186-202.
- Graevsky E. Y. & Medvedeva Y. A. (1948). "[Causes of damage of protoplasm during deep freezing]." *Zh. Obshchey Biologii* (Rus.) 9: 436-469.
- Hoagland H. & Pincus G. G. (1942). "Revival of mammalian sperm after immersion in liquid nitrogen." *J Genet Physiol* 25: 337-344.
- Isachenko E., Isachenko V., Katkov I. I., Dessole S. & Nawroth F. (2003). "Vitrification of mammalian spermatozoa in the absence of cryoprotectants: from past practical difficulties to present success." *Reprod Biomed Online* 6(2): 191-200.
- Isachenko E., Isachenko V., Katkov I. I., Rahimi G., Schondorf T., Mallmann P., Dessole S. & Nawroth F. (2004a). "DNA integrity and motility of human spermatozoa after standard slow freezing versus cryoprotectant-free vitrification." *Hum Reprod* 19(4): 932-9.
- Isachenko E., Isachenko V. & Katkov I. I. (2007). Cryoprotectant-Free Vitrification of Spermatozoa. In: *Vitrification in Assisted Reproduction: A User's Manual and Troubleshooting Guide*. Eds: M. J. Tucker and J. Liebermann. Oxon, UK, Infroma Healthcare Medical Books: 87-105.
- Isachenko E., Isachenko V., Weiss J. M., Kreienberg R., Katkov I. I., Schulz M., Lulat A. G., Risopatron M. J. & Sanchez R. (2008). "Acrosomal status and mitochondrial activity of human spermatozoa vitrified with sucrose." *Reproduction* 136(2): 167-73.
- Isachenko E., Isachenko V., Sanchez R., Katkov I. I. & Kreienberg R. (2010). Cryopreservation of spermatozoa: Old routine and new perspectives. In: *Principles and Practice of Fertility Preservation*. Eds: J. Donnez and S. S. Kim. Cambridge, UK, Cambridge University Press: Ch. 14, pp 177-99.
- Isachenko E., Mallmann P., Isachenko V., Rahimi G., Risopatron J. & Sanchez R. (2012). Vitrification Technique- New Possibilities for Male Gamete Low-Temperature Storage. In: *Cryopreservation / Book 1 (ISBN 979-953-307-300-1)*. Eds: I. I. Katkov, inTech. 1: Chapter 2 (in press).
- Isachenko V., Isachenko E., Katkov I. I., Montag M., Dessole S., Nawroth F. & Van Der Ven H. (2004b). "Cryoprotectant-free cryopreservation of human spermatozoa by vitrification and freezing in vapor: effect on motility, DNA integrity, and fertilization ability." *Biol Reprod* 71(4): 1167-73.
- Isachenko V., Isachenko E., Montag M., Zaeva V., Krivokharchenko I., Nawroth F., Dessole S., Katkov I. I. & van der Ven H. (2005). "Clean technique for cryoprotectant-free vitrification of human spermatozoa." *Reprod Biomed Online* 10(3): 350-4.
- Isachenko V., Maettner R., Petrunina A. M., Mallmann P., Rahimi G., Sterzik K., Sanchez R., Risopatron J., Damjanoski I. & Isachenko E. (2011). "Cryoprotectant-free vitrification of human spermatozoa in large (up to 0.5 mL) volume: a novel technology." *Clin Lab*(57): 643-650.
- Jahnel F. (1938). "[Resistance of human spermatozoa to deep cold]." *Klinische Wochenschrift* 17: 1273-1274.

- Jiao A., Han X., Critser J. K. &Ma H. (2006). "Numerical investigations of transient heat transfer characteristics and vitrification tendencies in ultra-fast cell cooling processes." *Cryobiology* 52(3): 386-92.
- Jiao A. J., Ma H. B. &Critser J. K. (2009). "Experimental investigation of cryogenic oscillating heat pipes." *Int J Heat Mass Transf* 52(15-16): 3504-3509.
- Katkov I. I., Katkova N., Critser J. K. &Mazur P. (1998). "Mouse spermatozoa in high concentrations of glycerol: chemical toxicity vs osmotic shock at normal and reduced oxygen concentrations." *Cryobiology* 37(4): 325-38.
- Katkov I. I., Isachenko E., Isachenko V. &Nawroth F. (2003). "Why can we vitrify mammalian spermatozoa without cryoprotectants? Physicochemical considerations." *Cryobiology* 47: 267.
- Katkov I. I. &Levine F. (2004). "Prediction of the glass transition temperature of water solutions: comparison of different models." *Cryobiology* 49(1): 62-82.
- Katkov I. I., Isachenko V., Isachenko E., Kim M. S., Lulat A. G.-M. I., Mackay A. M. &Levine F. (2006). "Low- and high- temperature vitrification as a new approach to biostabilization of reproductive and progenitor cells." *Int J Refrigeration* 29(3): 346-57.
- Katkov I. I., Isachenko V. &Isachenko E. (2007). Vitrification in Small Quenched Volumes with a Little Amount of or without Vitrificants: Biophysics and Thermodynamics. In: *Vitrification in Assisted Reproduction: A User's Manual and Troubleshooting Guide*. Eds:M. J. Tucker and J. Liebermann. London, UK, Infroma Healthcare: 21-32.
- Katkov I. I. (2008). High temperature stabilization by drying and storage at ambient temperatures as the emerging alternative to transgenic animal sperm cryobanking. Int-l Kirpichnikov's Conf. "*Genetics, Selection, and Breeding of Fish*", Saint-Petersburg, Russia.
- Katkov I. I. (2010). "Race for the pace: is the universal cryoprotocol a dream or reality?" *Cryobiology* 61: 374-375.
- Katkov I. I., Kan N. G., Cimadamore F., Nelson B., Snyder E. Y. &Terskikh A. V. (2011). "DMSO-free programmed cryopreservation of fully dissociated and adherent human induced pluripotent stem cells. 2011:981606.." *Stem Cells International* 2011: 981606.
- Koshimoto C., Gamliel E. &Mazur P. (2000). "Effect of osmolality and oxygen tension on the survival of mouse sperm frozen to various temperatures in various concentrations of glycerol and raffinose." *Cryobiology* 41(3): 204-31.
- Li X., Krawetz R., Liu S., Meng G. &Rancourt D. E. (2008). "ROCK inhibitor improves survival of cryopreserved serum/feeder-free single human embryonic stem cells." *Hum Reprod*.
- Lovelock J. E. (1953). "The mechanism of the protective action of glycerol against haemolysis by freezing and thawing." *Biochim Biophys Acta* 11(1): 28-36.
- Luyet B. &Hodapp A. (1938). "Revival of frog's spermatozoa vitrified in liquid air." *Proc Meet Soc Exp Biol* 39: 433-434.
- Luyet B. E. (1937). "The vitrification of organic colloids and of protoplasm." *Biodynamica* 1: 1-14.



- Maksudov G. Y., Shishova N. V. & Katkov I. I. (2009). Ch. 8, In the Cycle of Life: Cryopreservation of Post-Mortem Sperm as a Valuable Source in Restoration of Rare and Endangered Species. In: *Endangered Species: New Research*. Eds: A. M. Columbus and L. Kuznetsov. Hauppauge, NY, NOVA Science Publishers: 189-240.
- Martin-Ibanez R., Stromberg A. M., Hovatta O. & Canals J. M. (2009). "Cryopreservation of dissociated human embryonic stem cells in the presence of ROCK inhibitor." *Curr Protoc Stem Cell Biol* Chapter 1: Unit 1C 8.
- Martin-Ibanez R. (2012). Cryopreservation of human pluripotent stem cells: are we going in the right direction? In: *Cryopreservation / Book 1 (ISBN 979-953-307-300-1)*. Eds: I. I. Katkov, InTech. 1: *in press*.
- Mazur P. (1963). "Kinetics of Water Loss from Cells at Subzero Temperatures and the Likelihood of Intracellular Freezing." *J Gen Physiol* 47: 347-69.
- Mazur P. (1970). "Cryobiology: the freezing of biological systems." *Science* 168(934): 939-49.
- Mazur P., Leibo S. P. & Chu E. H. Y. (1972). "2-factor hypothesis of freezing injury - evidence from chinese-hamster tissue-culture cell." *Experimental Cell Res.* 71: 345-349.
- Mazur P. (1984). "Freezing of living cells: mechanisms and implications." *Am J Physiol* 247(3 Pt 1): C125-42.
- Mazur P., Katkov I. I., Katkova N. & Critser J. K. (2000). "The enhancement of the ability of mouse sperm to survive freezing and thawing by the use of high concentrations of glycerol and the presence of an Escherichia coli membrane preparation (Oxyrase) to lower the oxygen concentration." *Cryobiology* 40(3): 187-209.
- Mazur P. & Koshimoto C. (2002). "Is intracellular ice formation the cause of death of mouse sperm frozen at high cooling rates?" *Biol Reprod* 66(5): 1485-90.
- Mazur P., Leibo S. P. & Siedel G. E. (2008). "Cryopreservation of the germplasm of animals used in biological and medical research: Importance, impact, status, and future directions." *Biol Reprod* 78: 2-12.
- Mazur P. & Seki S. (2011). "Survival of mouse oocytes after being cooled in a vitrification solution to -196°C at 95° to 70,000°C/min and warmed at 610° to 118,000°C/min: A new paradigm for cryopreservation by vitrification." *Cryobiology* 62: 1-7.
- Merino O., Risopatron J., Sanchez R., Isachenko E., Figueroa E., Valdebenito I. & Isachenko V. (2011a). "Fish (*Oncorhynchus mykiss*) spermatozoa cryoprotectant-free vitrification: stability of mitochondrion as criterion of effectiveness." *Anim Reprod Sci* 124(1-2): 125-31.
- Merino O., Sanchez R., Risopatron J., Isachenko E., Katkov I. I., Figueroa E., Valdebenito I., Mallmann P. & Isachenko V. (2011b). "Cryoprotectant-free vitrification of fish (*Oncorhynchus mykiss*) spermatozoa: first report." *Andrologia: in press*.
- Milovanov V. K. (1962). [Reproductive Biology and Artificial Insemination of Animals] Rus. Moscow, Nauka.
- Mollamohammadi S., Taei A., Pakzad M., Totonchi M., Seifinejad A., Masoudi N. & Baharvand H. (2009). "A simple and efficient cryopreservation method for feeder-free dissociated human induced pluripotent stem cells and human embryonic stem cells." *Hum Reprod*.

- Morris G. J. (2006). "Rapidly cooled human sperm: no evidence of intracellular ice formation." *Human Reprod.* 21(8): 2075-83.
- Moskovtsev S. I., Lulat A. G. & Librach C. L. (2012). Cryopreservation of Human Spermatozoa by Vitrification vs. Slow Freezing: Canadian Experience. In: *Cryopreservation / Book 1 (ISBN 979-953-307-300-1)*. Eds: I. I. Katkov, inTech. 1: Chapter 3 (in press).
- Nawroth F., Isachenko V., Dessole S., Rahimi G., Farina M., Vargiu N., Mallmann P., Dattena M., Capobianco G., Peters D., Orth I. & Isachenko E. (2002). "Vitrification of human spermatozoa without cryoprotectants." *CryoLetters* 23(2): 93-102.
- Okuyama M., Isogai S., Saga M., Hamada H. & Ogawa S. (1990). "In vitro fertilization (IVF) and artificial insemination (AI) by cryopreserved spermatozoa in mouse." *J Fertil Implant (Tokyo)* 7: 116-119.
- Park S. P., Lee Y. J., Lee K. S., Ah Shin H., Cho H. Y., Chung K. S., Kim E. Y. & Lim J. H. (2004). "Establishment of human embryonic stem cell lines from frozen-thawed blastocysts using STO cell feeder layers." *Hum Reprod* 19(3): 676-84.
- Parkes A. S. (1945). "Preservation of human spermatozoa at low temperatures." *Br Med J* 2: 212-213.
- Perloff W. H., Steinberger E. & Sherman J. K. (1964). "Conception with Human Spermatozoa Frozen by Nitrogen Vapor Technic." *Fertil Steril* 15: 501-4.
- Polge C., Smith A. U. & Parkes A. S. (1949). "Revival of spermatozoa after vitrification and dehydration at low temperatures." *Nature* 164: 666-676.
- Pouplin M., Redl A. & Gontard N. (1999). "Glass transition of wheat gluten plasticized with water, glycerol, or sorbitol." *J Agric Food Chem* 47(2): 538-43.
- Rall W. F. & Fahy G. M. (1985). "Ice-free cryopreservation of mouse embryos at -196 degrees C by vitrification." *Nature* 313(6003): 573-5.
- Reubinoff B. E., Pera M. F., Vajta G. & Trounson A. O. (2001). "Effective cryopreservation of human embryonic stem cells by the open pulled straw vitrification method." *Hum Reprod* 16(10): 2187-94.
- Rezazadeh V. M., Eftekhari-Yazdi P., Karimian L., Hassani F. & Movaghar B. (2009). "Vitrification versus slow freezing gives excellent survival, post warming embryo morphology and pregnancy outcomes for human cleaved embryos." *J Assist Reprod Genet* 26: 347-354.
- Risco R., Elmoazzen H., Doughty M., He X. & Toner M. (2007). "Thermal performance of quartz capillaries for vitrification." *Cryobiology* 55: 222-229.
- Sanchez R., Risopatron J., Schulz M., Villegas J., Isachenko V., Kreinberg R. & Isachenko E. (2011). "Canine sperm vitrification with sucrose: effect on sperm function." *Andrologia*.
- Saragusty J. & Arav A. (2011). "Current progress in oocyte and embryo cryopreservation by slow freezing and vitrification." *Reproduction* 141: 1-19.
- Saragusty J. (2012). Genome Banking for Vertebrates Wildlife Conservation. In: *Cryopreservation / Book 1 (ISBN 979-953-307-300-1)*. Eds: I. I. Katkov, inTech. 1: in press.
- Schaffner C. S. (1942). "Longevity of fowl spermatozoa in frozen condition." *Science* 96: 337.

- Sherman J. K. (1963). "Questionable protection by intracellular glycerol during freezing and thawing." *J Cell Comp Physiol* 61: 67-83.
- Sherman J. K. (1964). "Dimethyl Sulfoxide as a Protective Agent During Freezing and Thawing of Human Spermatozoa." *Proc Soc Exp Biol Med* 117: 261-4.
- Smirnov I. V. (1949). "Preservation of domestic animal semen by deep cooling." *Sovetskaja Zootechnia* (Rus.). 4: 63-65.
- Spallanzani L. (1780). "Dissertazioni di fisica animale e vegetale." *Modano*.
- Stiles W. (1930). "On the cause of cold death of plants." *Protoplasma* 9: 459-468.
- Stubban C., Wesselschmidt R. L., Loring J. F. & Katkov I. I. (2007). Cryopreservation of human embryonic stem cells. In: *Human Stem Cell Manual. A Laboratory Guide*. Eds: J. F. Loring, R. L. Wesselschmidt and P. H. Schwartz. London, Elsevier: 47-55.
- Suzuki H. (2006). "Freeze-dried Spermatozoa and Freeze-dried Sperm Injection into Oocytes." *J Mamm Ova Res*(23): 91-95.
- Tada N., Sato M., Yamanoi J., Mizorogi T., Kasai K. & Ogawa S. (1990). "Cryopreservation of mouse spermatozoa in the presence of raffinose and glycerol." *J Reprod. Fertil* 89: 511-516.
- Tucker M. J. & Liebermann J., Eds. (2007). *Vitrification in Assisted Reproduction: A User's Manual and Troubleshooting Guide*. London, UK, Infroma Healthcare.
- Wagh V., Meganathan K., Jagtap S., Gaspar J. A., Winkler J., Spitkovsky D., Hescheler J. & Sachinidis A. (2011). "Effects of cryopreservation on the transcriptome of human embryonic stem cells after thawing and culturing." *Stem Cell Rev* 7: 506-517.
- Ware C. B. & Baran S. W. (2007). "A controlled-cooling protocol for cryopreservation of human and non-human primate embryonic stem cells." *Methods Mol Biol* 407: 43-9.
- Whittingham D. G., Leibo S. P. & Mazur P. (1972). "Survival of mouse embryos frozen to -196 degrees and -269 degrees C." *Science* 178(59): 411-4.
- Wikipedia (2011a). "21st Century Medicine."  
[http://en.wikipedia.org/wiki/Twenty-First\\_Century\\_Medicine](http://en.wikipedia.org/wiki/Twenty-First_Century_Medicine).
- Wikipedia (2011b). "KrioRus."  
<http://en.wikipedia.org/wiki/KrioRus>.
- Wikipedia (2011c). "Danila Medvedev."  
[http://en.wikipedia.org/wiki/Danila\\_Medvedev](http://en.wikipedia.org/wiki/Danila_Medvedev).
- Wilmot I. (1972). "The effect of cooling rate, warming rate, cryoprotective agent and stage of development on survival of mouse embryos during freezing and thawing." *Life Sci* II 22: 1071-1079.
- Yokoyama M., Akiba H., Katsuki M. & Nomura T. (1990). "Production of normal young following transfer of mouse embryos obtained by in vitro fertilization using cryopreserved spermatozoa." *Exp. Anim* 39: 125-138.
- Zhai H. & Salomon D. (2011). "Low Temperature Property Evaluation and Fragility of Asphalt Binders Using Non-Arrhenius Viscosity Temperature Dependency."  
<http://www.technopave.com/publications/Fragility-of-Asphalt-Non-Arrhenius-Viscosity.pdf> 05-0971.

Zhou C. Q., Mai Q. Y., Li T. & Zhuang G. L. (2004). "Cryopreservation of human embryonic stem cells by vitrification." *Chin Med J (Engl)* 117(7): 1050-5.

# Vitrification Technique – New Possibilities for Male Gamete Low-Temperature Storage

E. Isachenko, P. Mallmann, G. Rahimi, J. Risopatròn,  
M. Schulz, V. Isachenko and R. Sánchez  
*Woman Hospital, University of Cologne  
Germany*

## 1. Introduction

According to the recent scientific achievements in cryobiology at present the vitrification belong to perspective technologies.

### What is the reason?

Because:

- The method is cheap and quick.
- Due to lowering the temperature of solution's glass transition the permeable cryoprotectants prevents the actual freezing of solution and allows to maintain its some flexibility in a glassy phase.
- Vitrification without permeable cryoprotectants allows to avoid the cryoprotectants toxicity and osmotic stress; the damage of plasmatic and mitochondrial membrane during equilibration with cryoprotectants; protects of plasmatic and mitochondrial membrane against lipid peroxidation and formation of reactive oxygen species and DNA damage.

Cryobiology is a rapidly evolving field which only relatively recently has found broad applications in reproductive medicine. However, as any emerging technology, it has both a great potential and a need for further developments (Petrunkina, 2007).

According to worldwide experience, successful cryopreservation of spermatozoa from different kind of animal including human for long-term storage (cryobanking of genome) or relatively short-term storage (artificial insemination) in conjunction with assisted reproductive technologies allows to promote long-term cryopreservation programmes. The use of programmable or non-programmable "slow" (conventional) freezing (McLaughlin et al., 1990; Yin and Seibel, 1999; Stanic et al., 2000) allows to preserve relatively large volume of diluted ejaculate or prepared spermatozoa from 0.25 to 1.0 mL with good rates of motility after thawing (Sawetawan et al., 1993; Larson et al., 1997) and acceptable levels of integrity of acrosomal and cytoplasmic membranes, in other words with sufficiently high quality post-thaw characteristics (Hammadeh et al., 1999; Duru et al., 2001; Meseguer et al., 2004; Isachenko et al., 2003, 2008). It does also provide acceptable protection against membrane changes and destabilization induced by cryopreservation (Glander and Schaller, 2000; Schuffner et al., 2001).

To avoid the lethal intracellular ice formation, the cryoprotective solution as ruler contains buffers, carbohydrates (glucose, lactose, raffinose, sucrose and trehalose), salts (sodium citrate, citric acid), egg yolk and antibiotics including permeable cryoprotectant glycerol or other cryoprotectives (Mazur, 1963; Barbas & Mascarenhas, 2009) in combination with comparably slow rates of freezing (Gao et al., 1997) are widely used for these purpose. The aim of slow cooling rates is to maintain a very delicate balance between ice crystal formation and growing concentration of dissolved substances. Conventional freezing procedure for mammalian spermatozoa traditionally includes the following stages of manipulations:

1. slow, step-wise adding of freezing solution to the ejaculate
2. cooling during 20 to 45 min
3. warming in water bath and
4. treatment of spermatozoa by the density gradient or the swim-up procedure (McLaughlin et al., 1990; Yin and Seibel, 1999; Stanic et al., 2000).
5. The ultimate target of the last manipulation is the removal of permeable cryoprotectants.

As a rule, a pre-requisite for that is a dilution of semen suspension with culture medium in order to reduce the toxicity of permeable cryoprotectant (according to manufacturer's instructions for cryoprotectant of choice). This is associated with additional costs and, not at least, with environmental and adaptation challenges for spermatozoa. In fact, sensitivity of spermatozoa to additional mechanical manipulation is increased after freezing-thawing, and the negative effects of cryopreservation on cell viability and functional competence can be aggravated by additional procedures. The problem is that the addition and, in particular, the removal of permeable osmotically-active cryoprotective agents (permeable cryoprotectants) before cooling and after warming can induce lethal stress due to intracellular ice formation, intracellular eutectic formation or so-called 'dilution (toxic) effects' (Fraga et al., 1991, Petrunkina, 2007) including chilling injury, cytoplasm fracture or even effects on the cytoskeleton (Critser et al., 1988; Fraga et al., 1991; Pérez-Sánchez et al., 1994). The further problems include the chemical toxicity of cryoprotectants and their possible repercussions on the genome or genome-related structures of mammalian spermatozoa (Hammadeh et al., 1999; Gilmore *et al.*, 1997). Moreover, spermatozoa which survive the cryopreservation stress are likely to have undergone subtle functional changes associated with biophysical and biochemical factors influenced by cryoprotectants, which will affect their fertilizing ability (Petrunkina, 2007).

Actually, the problem of the cooling and warming processes is the lethality which closely associated with the intermediate zone of temperature (-10 to -60 °C) that cells must traverse twice during cooling and once during warming (Mazur, 1963).

One of relatively recent and much discussed cryobiological emerged technologies within the field of the reproductive cryobiology is the spermatozoa vitrification (cryopreservation by direct plunging into liquid nitrogen). Vitrification is an alternative method that can also be applied to achieve the same purpose and does not use the special extenders. This method is based on the rapid cooling of the cells by immersion into liquid nitrogen, and, thereby, is the key factor reducing the chance of the formation of big ice crystals. In contrast to the programmable ("slow") conventional freezing, vitrification has series of technological advantages useful for the practice: it renders the use of permeable cryoprotectants superfluous and, in addition, is much faster, simpler in application and more cost-effective

than conventional freezing. In spite of that this method has been investigated extensively and successfully applied to female gametes and embryos of different mammalian species including humans (Rall & Fahy, 1985; Chen et al., 2001; Reed et al., 2002; Cervera & Garcia-Ximénez, 2003; Isachenko et al., 2005b, 2007; Silva & Berland, 2004), however, it cannot be directly extrapolated to male gametes, due to deleterious osmotic effect of high concentrations of permeable cryoprotectants.

To date, publications dedicated to this topic are rare (Nawroth, et al., 2002; Koshimoto & Mazur, 2002; Isachenko et al., 2004a, b, 2008). Recent work has reversed this situation in that favorable results have been obtained in human spermatozoa after excluding permeable cryoprotectants from cryopreservation solutions, increasing the cooling rate and using carbohydrates, proteins and other extracellular agents, to increase the viscosity of the surrounding medium of cells and prevent the formation of any intra- and big extracellular crystals (Isachenko et al., 2004a, b). It was shown that permeable-cryoprotectants-free vitrification only with protein (Nawroth et al, 2002; Isachenko et al, 2003, 2004a,b, 2005a) or in combination with sucrose (Isachenko et al., 2008 2011a,b,c,d; Sanchez et al., 2011a, b) as a non-permeable cryoprotectant provides a high recovery rate of motile cells and effectively protects the mitochondrial membrane and the DNA integrity of spermatozoa after warming (Isachenko et al., 2004a, b; 2008). And it is not surprising. According to common point of view the non-permeable cryoprotectants plays the supporting role at permeable cryoprotectants. They binds of extracellular water and at the same time plays anti-toxic role (Kuleshova et al., 1999) decreasing of harmful properties of permeable cryoprotectants. In general, the inclusion of osmotically active, non-permeating compounds into the vitrification solution leads to additional rehydration of cells and, as a result, to decreasing toxic effects of the permeable cryoprotectants on intracellular structures. The non-permeable cryoprotectant sugars possess a unique property: stabilization of a cell membrane (Nakagata & Takeshima, 1992, 1993; Koshimoto et al., 2000; Koshimoto & Mazur, 2002).

Also, the application of this modified cryopreservation technique to human spermatozoa allowed to avoid the toxic effect caused by adding and removing of permeable cryoprotectants including the negative effects on the cells' genetic material (Pérez-Sánchez et al., 1994). In our earlier works we have shown that cryopreserved without permeable cryoprotectants human spermatozoa preserved their relatively high motility rate with ability to fertilize oocytes in vitro (Nawroth et al., 2002; Isachenko *et al.*, 2003; 2004a, b). No statistical differences in parameters such as viability, recovery rate or percentage of morphologically normal spermatozoa with undamaged DNA were noted between vitrified and conventionally frozen cells (Nawroth et al., 2002). However, it was observed that the number of cryopreserved spermatozoa displaying features of acrosome reaction was statistically different from that in freshly prepared swim-up spermatozoa (Isachenko *et al.*, 2004a,b, 2005a, 2008, 2011a,b).

In contrast to the programmable (slow) conventional freezing the vitrification renders redundant the need for special cooling programs addition of permeable cryoprotectants. It is much faster, simpler and more cost-efficient while still effectively protecting spermatozoa from cryo-injuries (Nawroth et al, 2002; Isachenko et al, 2003, 2004a, b, 2005, 2008) and does not require expensive equipment or special cooling procedures. Spermatozoa, vitrified by such technology, would be ready for further use without any additional treatment (centrifugation, separation in the gradient, removal of cryoprotectant and others) immediately after thawing.

Successful pregnancies and births have been reported when using vitrified oocytes and embryos, and vitrification protocols have started to form an important part as well of human as of animal reproductive medicine. Although sperm vitrification techniques have been studied in vitro, first successful pregnancies and live birth after fertilization with vitrified spermatozoa have been reported.

This chapter we would like to present contents the interesting results which we have had in the first time achieved using developed us vitrification technique based on using only of protein and carbohydrates as non-permeable cryoprotectants and applying to some mammalian and fish species.

In our presentation we will not touch the historical questions of vitrification of spermatozoa as well, but will concentrate us only on own experience according to vitrification of spermatozoa with using only non-permeable cryoprotectants. This theme was well covered in our previous publications (E. Isachenko et al., 2003, 2008, 2011a; Katkov et al., 2006).

In this chapter we will in detail discuss our new data which we have got in our investigation after vitrification of human, dog and fish spermatozoa.

## **2. New capillary technology (Isachenko et al., 2011c) for vitrification of small volume of human spermatozoa and practical application**

Varied methods to vitrify spermatozoa have been described previously: cryo-loops, droplets- and open pulled straw method (Nawroth et al, 2002; Isachenko et al., 2004a,b, 2005, 2008). According to these results it is possible to achieve up to 60%- and 20% -motility levels after thawing in normospermic and oligo-astheno-terato-zoospermic patients, respectively, depending on vitrification method selected and the quality of the original ejaculate. Independent from the vitrification technique the vitrified spermatozoa can be processed for further use immediately after warming without additional treatment such as centrifugation, gradient separation, removal of cryoprotectants etc is required. This simplicity for practical purposes represents one of the most attractive advantages of our technology. It is worth to mention that the protocol for vitrification does include swim up treatment, therefore, after swim up, vitrification and warming spermatozoa are also free from seminal plasma with potential pathogens. "Slow" freezing of human spermatozoa traditionally proposes the removing of permeable cryoprotectant after thawing.

This «*removal of permeable cryoprotectants*» is the ultimate target of the last manipulation. As a rule, a pre-requisite for that is a dilution of semen suspension with culture medium in order to reduce the toxicity of permeable cryoprotectant (according to manufacturer's instructions for cryoprotectant of choice). This is associated with additional costs and, not at least, with environmental and adaptation challenges for spermatozoa. In fact, sensitivity of spermatozoa to additional mechanical manipulation is increased after freezing-thawing, and the negative effects of cryopreservation on cell viability and functional competence can be aggravated by additional procedures (Petrunkina, 2007). Cryopreservation induces extensive damage to cells during both freezing and thawing. According to present knowledge, the effective induction of anabiosis in cells at very low temperatures (in liquid nitrogen at -196°C, for example) can be achieved by optimizing the multi-factorial freezing process (Lozina-Lozinski, 1982), commonly with the use of permeable cryoprotectants (Levin, 1982). Acting by depressing the freezing point and by



binding intracellular water, the permeable and non-permeable cryoprotectants help to prevent ice formation, and thereby to reduce the cryo-damage (Andrews, 1976; Franks, 1977).

Several protocols of spermatozoa separation are available (e.g. swim-up from the ejaculate, single wash of ejaculate and swim-up from pellet, double wash of ejaculate and swim-up from pellet). However, any methodology needs the use of previous centrifugation. Most of the current technologies for sperm vitrification have an obvious shortcoming in terms of standardization of the portion volume. In particular, as the diameter of the pulled part of straw is not uniform, the volumes of the portions packaged in that way can not be standardized. Here we have reported the vitrification methodology using standard capillaries which can be supplied by industrial manufacturers. The technique was performed as follow (Isachenko V et al., 2011c). All specimens used for this study had fulfilled following quality criteria for spermatozoa concentration, motility and morphology: less than 20 millions spermatozoa/mL, 35 % progressive motile and minimum 3 % morphologically normal spermatozoa. Semen analysis was performed according to published guidelines of the World Health Organization (WHO, 1999). Prior to vitrification, the sedimented spermatozoa were diluted with 0.25 M sucrose (end concentration) in sperm preparation medium at room temperature (Isachenko et al., 2008). The final concentration of spermatozoa was approximately of  $0.5 \times 10^6$  spermatozoa/mL. Diluted suspensions were maintained at room temperature for 5 min before the cooling procedure. Spermatozoa were prepared and portioned for aseptic vitrification in the following way. Specially for our purposes, 50  $\mu$ L-plastic capillaries (Fig.1) were manufactured from hydrophobic material as vehicles for cooling sperm cell suspensions (Gynemed GmbH & Co. KG, Lensahn, Germany). The end of the straw was labeled on the top to mark the cutting-off position (Fig.1, arrows). The capillary was filled with 10 $\mu$ L of spermatozoa suspension by aspiration (Fig. 1a). It was absolutely crucial to avoid that the inner surface of the capillary become moist during packaging procedure. Aspirating the volume of sperm cell suspension above the mark and correcting it by lowering the fluid level inside the capillary after aspiration is technologically wrong and would result in excess of portion's volume after thawing. After the aspiration was completed, the capillary was inserted into 0.25 ml straw (Medical Technology GmbH, Bruckberg, Germany). One end of this straw was sealed in advance using heat-sealer (Cryo Bio System, Paris, France). After sealing the second end of the straw (Fig. 1b), the straw was plunged into liquid nitrogen and cooled at a cooling speed of 600°C/min. The speed of cooling was determined using a Testo 950 electrical thermometer (Testo AG, Lenzkirch, Germany) using 0.2 mm electrode located inside of the capillary. Hermetical heat-sealing of 0.25 mL straw can be achieved using flame of alcohol burner and forceps or any commercial equipment (including ultrasound equipment because of large distance between spermatozoa suspension and focus of sonographic appliance). Spermatozoa were stored in liquid nitrogen at least for 24 h before warming. For warming, capillary was removed from isolating 0.25 mL straw. The straw was disinfected with ethanol in the area where the marked end of capillary was (Fig. 1, arrows). The second end of capillary is fixed tightly on the inner surface of the straw, and the part of straw containing spermatozoa is still half submerged in liquid nitrogen (Figs. 1c,d). The upper part of the straw was cut off with sterile scissors as close as possible to the marked end of the capillary, just above the mark without touching the marked end of capillary. The capillary

was expelled with a conical bolt (Fig. 1d). For this purpose, conical bolt (instead the conical bolt forceps can be used in place) is inserted into inner part of the capillary and pulled off the straw. The final warming up of spermatozoa is achieved by immersing of capillary without conical apex (capillary must be open from both sides) with vitrified spermatozoa into 1.8 mL centrifuged tube with 0.7 mL pre-warmed to 37°C vitrification medium for approximately 20 sec. (Fig. 1e). It is important to note that the volume of vitrified suspension after warming is not decreased (Fig 1e). Finally, the suspension of spermatozoa was expelled from the capillary for immediate evaluation of spermatozoa quality. Using this technique the exactly quantifiable volumes of spermatozoa samples were obtained: 10  $\mu$ L suspension of spermatozoa were vitrified, 10  $\mu$ L were thawed and the same 10  $\mu$ L added to the respective volume of medium for ICSI or IVF. Thus, one of the most important features of this novel method of vitrification in capillaries is its potential for standardization which can be used for the routine clinical practice. The results of the present study let suggest that cryopreservation by vitrification helps to preserve essential determinants of spermatozoa function, such as motility and plasma membrane integrity. It is well known that spermatozoa cryopreservation is associated with a large decline in spermatozoa viability and other sperm functional parameters (Petrunkina, 2007). In the present study we have compared spermatozoa quality after vitrification by our method with spermatozoa quality after conventional freezing with addition of permeable cryoprotectant. The outcomes indicated that vitrification in capillaries compare to conventional freezing preserved better the motility of spermatozoa (after warming/thawing: 28.0  $\pm$  6.0 % *vs* 18.0  $\pm$  9.2 %, respectively,  $P < 0.05$  and in fresh control 35.0  $\pm$  9.5%; after 24 h *in vitro* culture: 12.0  $\pm$  2.8 % *vs* 5.0  $\pm$  3.1 %, respectively,  $P < 0.05$  and in fresh control 20.0  $\pm$  3.9%; after 48 h *in vitro* culture: 6.0  $\pm$  1.0 % *vs* 0.5  $\pm$  0.02 %, respectively  $P > 0.1$  and in fresh control 10.0  $\pm$  1.9% [Fig. 2]) and their plasma membrane integrity (56.0  $\pm$  5.1 % *vs* 22.0  $\pm$  3.5 %, respectively,  $P < 0.05$  and in fresh control 96.0  $\pm$  0.6 %,  $P < 0.05$  [Figure 3]) which was assessed with LIVE / DEAD sperm viability kit (LIVE/DEAD Sperm Viability Kit, Molecular Probes cat no. L-7011, Eugene, OR, USA). Pilot results have been obtained with respect to evaluating capacitation-like changes associated with cryopreservation, so called "cryo-capacitation" (Cormier and Bailey, 2003). A body of evidence suggests that some spermatozoa' intracellular signaling pathways can be affected during cryopreservation, and after warming spermatozoa display features commonly observed in capacitating or capacitated spermatozoa (Green and Watson, 2001; Petrunkina et al., 2005; Vadnais and Roberts, 2010). It is important, however, to emphasize that the changes induced by cryo-preservation are similar to those of capacitation only at the functional level, and they seem to differ at the molecular level, and with respect to pathways and signaling mechanisms involved (Cormier and Bailey, 2003). Our observations imply that permeable cryoprotectant-free aseptic vitrification is associated with lesser damage to acrosomes compare to conventional freezing (55.0  $\pm$  5.8 % *vs* 21.0  $\pm$  3.8 %, respectively,  $P < 0.05$  and in fresh control 84.0  $\pm$  3.1%,  $P < 0.05$  [Fig. 4]). However, the levels of membrane changes related to "cryo-capacitation" assessed by CTC in vitrified spermatozoa were comparable with those after conventional freezing (8.0  $\pm$  1.1% *vs* 9.0  $\pm$  2.2%, respectively,  $P < 0.01$  and in fresh control 2.0  $\pm$  0.3%,  $P < 0.05$ , [Figure 5]). Changes in the acrosomal membrane status and permeability associated with the capacitation we have evaluated by using the double fluorescence chlortetracycline (CTC)-Hoechst 33258 staining technique (Kay et al, 1994). Nevertheless, the exposure to low temperatures can affect those crucial signaling mechanisms which can not be monitored

by CTC. Thus, further studies with additional, advanced techniques are needed to investigate the changes induced by vitrification in its complexity (e.g. targeting specific pathways and membrane processes such as changes in lipid architecture and/or protein kinases/phosphatases regulated pathways). Given the fact that the outcome of basic spermatozoa quality was comparable (or even better) that after conventional freezing, other advantages of the vitrification process must be taken into account. During conventional procedure, the success of applying permeable cryoprotectants for cryopreservation of varied cells and tissues is inseparably linked to such cryoprotectant properties as their ability to permeate rapidly through cellular membrane and their toxicity (Gilmore et al, 1997). These properties are directly connected to osmotic damages of cells during saturation with permeable cryoprotectants before freezing and then at time of cryoprotectants removing after thawing (Gao et al, 1995, Petrunkina, 2007). It is known that human spermatozoa contain large quantities of proteins, sugars, and other components that may act as natural cryoprotectants. Our technology does not presuppose the use of permeable cryoprotectant. In practical terms, permeable cryoprotectant-free vitrification technology for the cryopreservation of spermatozoa (in straws) instead traditional slow freezing with permeable cryoprotectants is already used in following centers: our university's maternity hospital ([www.uniklinik-ulm.de](http://www.uniklinik-ulm.de)): IVF Centers in Temuco, Chile (about 200 IUI cycles/year) and in Ulm, Germany ([www.kinderwunsch-ulm.de](http://www.kinderwunsch-ulm.de)) (about 1,000 IVF cycles/year). First successful pregnancies and birth of healthy babies has been recently achieved with spermatozoa vitrified without permeable cryoprotectants (Isachenko et al., 2011b). In summary, the newly developed technology of aseptic vitrification of human spermatozoa in capillaries can effectively preserve these cells from cryo-injures. Spermatozoa, vitrified by this technology, are free from seminal plasma owing to swim up procedure preceding vitrification and are free from permeable cryoprotectants. They are ready for further use immediately after warming without any additional treatment. Therefore, the reported technology has a great potential for use in ICSI / IVF.

As successful application of this vitrification technology for routine practice is born of two healthy babies (Isachenko et al., 2011b). We would like shortly present here the history of this case. A couple, both 39 years old, underwent assisted reproduction due to severe endometriosis and oligo-astheno-terato-zoospermia ( $13 \times 10^6$  motile spermatozoa/ml; with 42% of progressive motility and 8% morphologically normal spermatozoa [WHO, 1999]). Cryopreserved spermatozoa were used because the partner was absent during the oocyte retrieval procedure. The swim up-processed spermatozoa were diluted and proceeded with vitrification solution according our technique, described above, to achieve a final concentration of  $2,5 \times 10^6$  spermatozoa/ml and 10 $\mu$ l aliquots were vitrified with using of Cut-Standard-Straws (CSS, Isachenko *et al.*, 2007) which was chosen as the prototype of our capillary technology. The spermatozoa were kept frozen in liquid nitrogen (at -196°C) for 7 months. Only the warming technique was different from newly developed one and supposed the concentrations of spermatozoa by centrifugation after warming. The changes in following physiological and morphological parameters of thirty minutes after warming of vitrified spermatozoa and the freshly prepared swim-up were investigated for progressive motility, capacitation-like membrane changes due to determining of phosphatidylserine translocation (PST). The capacitation-like membrane changes was investigated due to determining of phosphatidylserine translocation (PST) in the sperm with applying the annexin V-FITC staining technique (APOPTESTTM-FITC, Nexins Research, the Netherlands).

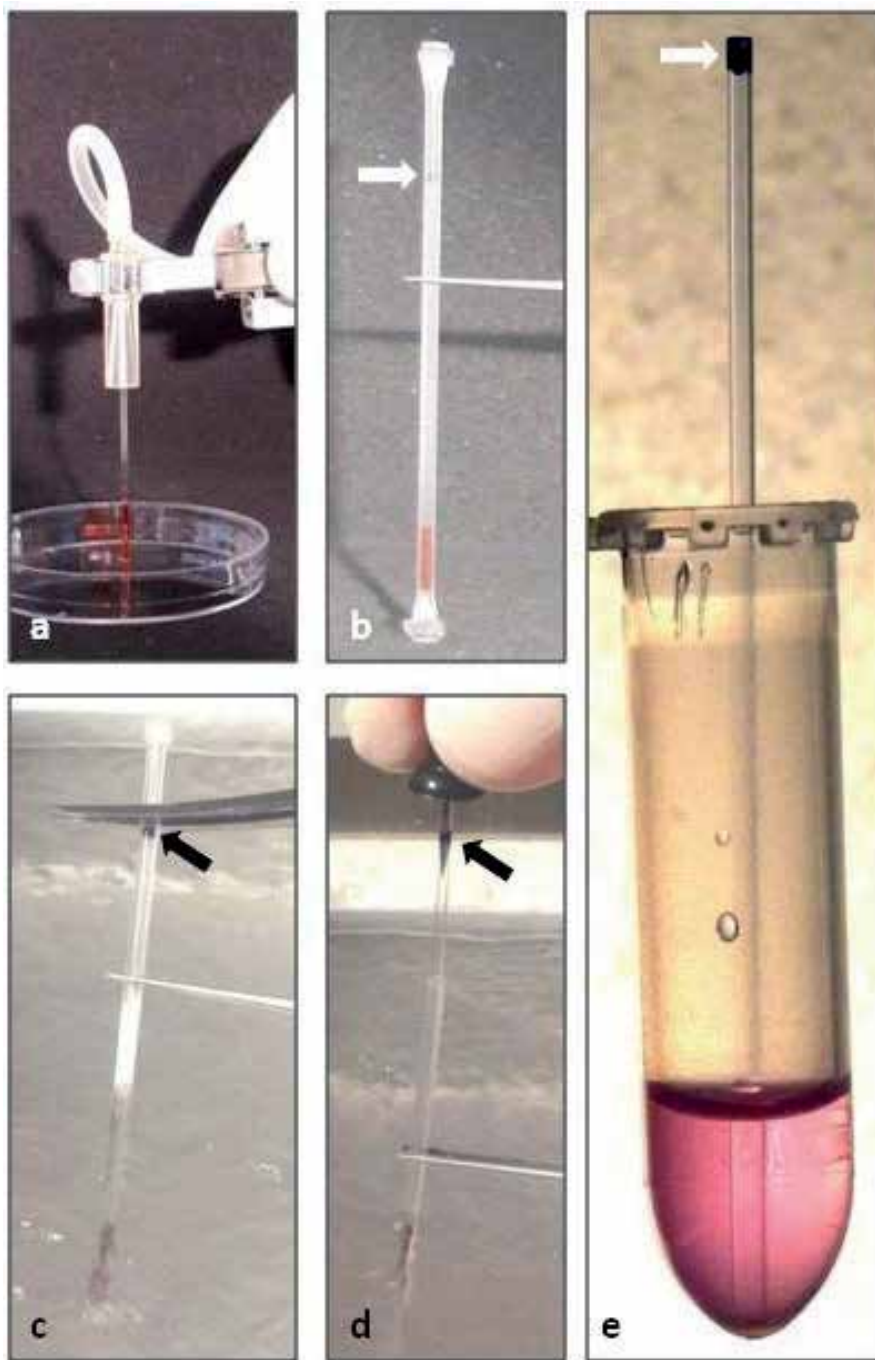

(Arrows) marked end of 50 µL capillary, (a) aspiration of spermatozoa suspension in straw, (b) 50 µL capillary sealed in 0.25 mL straw, (c) cutting of 0.25 mL straw, (d) expelling of 50 µL capillary from 0.25 mL straw, (e) warming of spermatozoa.

Fig. 1. Schematic illustration of human spermatozoa vitrification with 50 µL capillary.

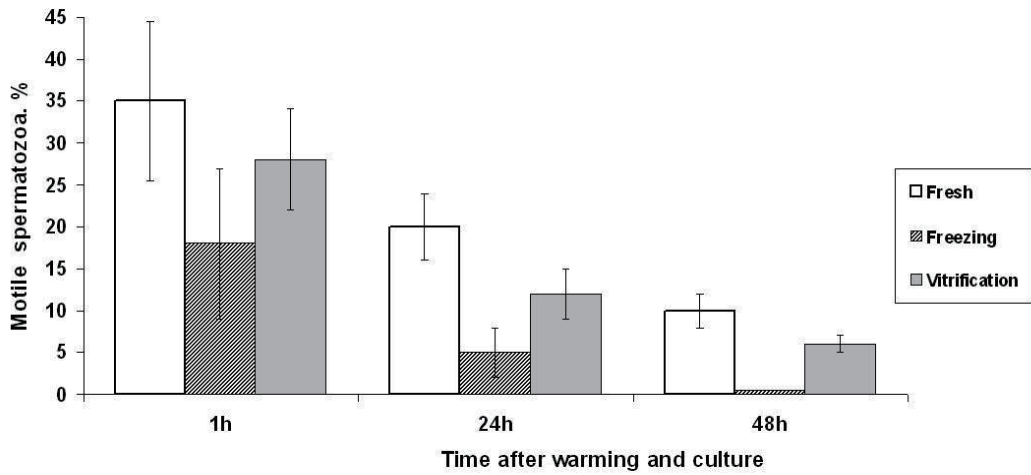

All rates in respective groups are significantly different ( $P < 0.05$ ).

Fig. 2. Motility of human spermatozoa after conventional freezing and vitrification.

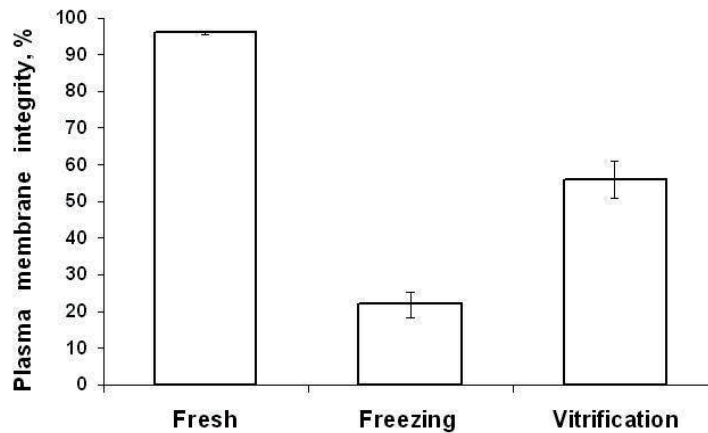

All rates in respective groups are significantly different ( $P < 0.05$ ).

Fig. 3. Plasma membrane integrity of human spermatozoa after conventional freezing and vitrification.

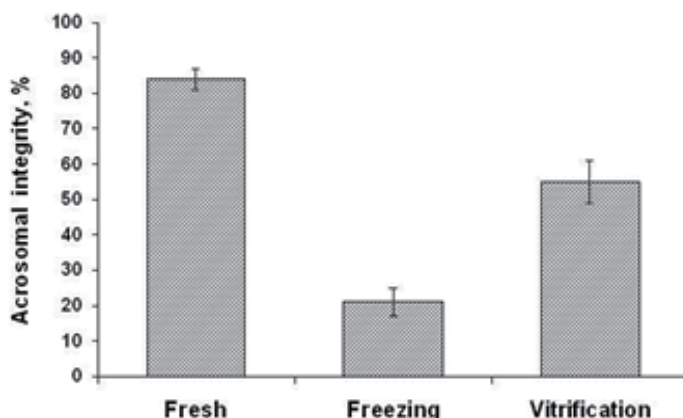

All rates in respective groups are significantly different ( $P < 0.05$ ).

Fig. 4. Acrosomal integrity of human spermatozoa after conventional freezing and vitrification.

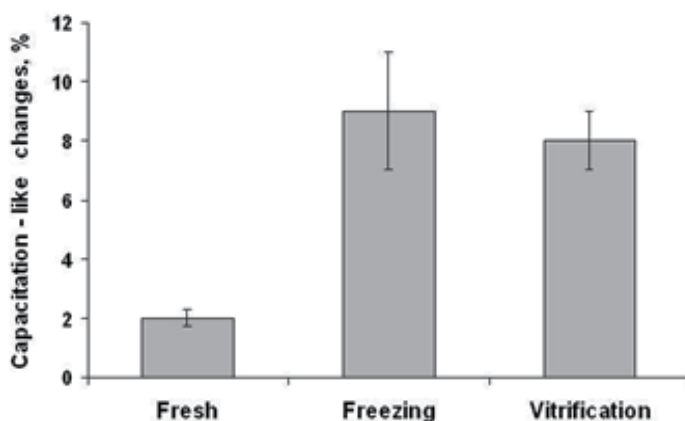

Rates in groups after freezing and vitrification are similar ( $P > 0.5$ ).

Fig. 5. Capacitation-like changes of human spermatozoa after conventional freezing and vitrification.

The mitochondrial membrane potential integrity was evaluated due to measurement of the changes in the ( $M \Delta \Psi$ ) using a unique fluorescent cationic dye, 5,5', 6,6'-tetachloro-1-1', 3,3'-tetraethyl-benzamidazolocarboxyanin iodide. The results were as following: progressive motility 60% *vs* 90%, correspondingly, 10% were identified as displaying a 'capacitation' CTC pattern and 5% as displaying an 'acrosome reaction' pattern, as compared to 8% and 5% in freshly prepared swim-up sperm respectively; 63% of spermatozoa were classified as having high mitochondrial membrane potential (*vs* 96% in freshly prepared spermatozoa).

From ten ICSI-ed with vitrified spermatozoa oocytes 6 oocytes showed signs of normal fertilization and two PN-oocytes were culture subsequent 24 hours. At day of embryo transfer two 4-blastomere embryos of Grades "a" (4a) and "b" (4b) (Steer et al., 1992) were

transferred to the uterus cavity under ultrasonographic guidance. Fifteen days after embryo transfer, the maternal  $\beta$ -hCG level was 360 IU/L and two healthy boys were born at term.

These data supports the notion that: i) cells can be frozen effectively without toxic permeable cryoprotectants, and ii) such frozen material could in principle be lyophilized. It is, however, critical to ensure that freeze-drying is not associated with the genetic and developmental abnormalities that have been observed after fertilization with mouse freeze-dried sperm (Ward *et al.*, 2003).

Cryopreservation is normally achieved through a tertiary combination of cells, permeable cryoprotectants and low temperature environment. In contrast, our cryopreservation protocol can be considered as a simplified binary combination of cells (in a simplified medium containing sucrose as a natural cryoprotectant) and a cold environment. The birth of two healthy babies using this *in vitro* fertilization technique is not only the first report on successful fertilization using vitrified spermatozoa (which has obvious practical advantages for assisted reproduction techniques). The above protocol also demonstrates that highly organized cells (human spermatozoa) may be effectively frozen-dried (lyophilized) with the recovery of their most important physiological function after thawing – propagation of genetic hereditary information and subsequent birth of new individuals. Of course, it would need to be proved on a large number of ejaculates that the damage produced by vitrification does not exceed the damage produced by conventional freezing and that there are no deleterious effects on the genetic integrity of sperm after vitrification (Ward *et al.*, 2003). These aspects, however important, are outside the scope of this case report.

### **3. New technology for vitrification of spermatozoa in big volume (Isachenko et al., 2011d)**

Actually, the technique which is not acceptable for different volumes of the same object is incomplete and needs subsequent investigations and development. In this case the next aim of our research was development the acceptable vitrification methodology for big volume of spermatozoa with possibility to use cryopreserved ejaculate for intrauterine insemination. At the beginning of 2011 we have published (E. Isachenko et al., 2011a) the prototype of our big-volume vitrification technology the success of which a healthy baby was born after intrauterine insemination with vitrified spermatozoa (Sánchez et al., 2011a). We would like shortly present the history of this case. A 39-year-old patient and her 35-year-old husband, with a 3-year history of primary infertility, were referred to our center for infertility treatment. Laparoscopy revealed patency of the Fallopian tubes and no evidence of endometriosis or pelvic adhesions. Semen analysis of the husband showed oligo-astheno-terato-zoospermia (WHO, 1999). Despite the poor quality of ejaculate parameters, for financial reasons the patients decided to try intra-uterine insemination (IUI). For IUI the spermatozoa from two ejaculates obtained 3 days apart were vitrified. The volume of the first ejaculate was 1.9 ml, concentration  $37.8 \times 10^6$  spermatozoa/ml, 8% of progressive “a” and “b” motility, 10% of morphologically normal spermatozoa, and  $0.2 \times 10^6$  round cells/ml. The volume of the second ejaculate was 3.9 ml, concentration  $11.2 \times 10^6$  spermatozoa/ml, 27% progressive motility, 10% of morphologically normal spermatozoa and  $1.2 \times 10^6$  round cells/ml. The swim up-processed spermatozoa were diluted and proceeded with vitrification solution according our technique, described above, to achieve a final

concentration of  $1 \times 10^6$  spermatozoa/ml. All subsequent manipulations were performed at room temperature strictly in a horizontal position to prevent a loss of suspension (E. Isachenko et al., 2011a). Aliquots (100  $\mu$ l) of the diluted sperm suspension were aspirated into one half of 0.25 ml plastic straws (MTG, Bruckberg, Germany); these were then placed in 0.5 ml plastic straws (MTG) and hermetically sealed from both sides to protect the suspension from direct contact with liquid nitrogen. The closed straw-systems, strictly maintained horizontal, were then immersed into liquid nitrogen and stored until use. From two ejaculates three straws were cryopreserved, each with 100  $\mu$ l of spermatozoa suspension in concentration of  $1 \times 10^6$  spermatozoa/ml. Special for this case we have decided to investigate the presence of reactive oxygen species (ROS) in ejaculated and prepared spermatozoa before and after vitrification. The reason was the following. It is known that poor ejaculate quality is closely associated with elevated concentrations of leucocytes (normal values  $<1$  million/ml). The presence of leucocytes can lead to oxidative stress (Henkel and Schill, 2003; Henkel et al., 2005, 2010). Therefore, we determined the concentration of leucocytes in ejaculates due to leucocytes quantifying by an indirect immunofluorescence (IIF) method (Villegas et al., 2002) and presence of the following antibodies were checked: anti CD45 for all leukocytes (M 855-DAKO, Hamburg, Germany, in concentration of 1/50 in PBS with 5% BSA), anti CD15 for granulocytes (M 733-DAKO, Hamburg, Germany, in concentration of 1/100 in PBS with 5% BSA) or anti CD68 for macrophages (M 718-DAKO, Hamburg, Germany, in concentration of 1/600 in PBS with 5% BSA). However, in spite of the presence of a large numbers of round cells, the IIF was negative for all tested monoclonal antibodies, indicating high levels of spermatogenic cells. The presence of ROS in ejaculates was tested using a chemiluminescence assay (Aitken and Clarkson, 1987). Only the mild increasing of ROS to 76.960 RLU  $\times 10^7$ /live sperm was noted (normal value: 35.000 RLU  $\times 10^7$ /live sperm (Henkel et al, 1997). However, it is known that ROS in semen samples of oligozoospermic patients usually is slightly increased (Kumar et al., 2009). On the day of ovulation all three cryopreserved samples of spermatozoa suspension were thawed as described in E. Isachenko et al. (E. Isachenko et al., 2011a), the sperm pellet was resuspended in 500  $\mu$ l of sperm preparation medium pre-warmed to 37°C and used immediately for intrauterine insemination. The suspension of spermatozoa before insemination (30 min post-warming) had a concentration of  $2.7 \times 10^6$  spermatozoa/ml with 60% of progressive motility. Fifteen days after IUI, biochemical pregnancy was confirmed by  $\beta$ -hCG level of 125 IU/L and on 29 December 2010 a healthy male baby was born.

Our finding has confirmed that the aseptic vitrification technique (without use of permeable cryoprotectants) is not only instrumental in effectively preserving spermatozoal function (Isachenko et al., 2011a, b, c, d, Sánchez et al., 2011), but could also have a massive potential for storage of motile spermatozoa for intrauterine insemination, for example, in cases of oligo-astheno-zoospermic patients.

However, the described methodology for vitrification of big-volume spermatozoa suspension is complicated, because exist often dangerous that sperm suspension will flows out the specimen straw and stick together to the inner wall of packaging straw during vitrification procedure. In this case it will be difficult to remove the specimen straw from the packaging one before warming. According to our opinion the technique must be as simple as possible and at the same time with absolute repeatability and the results have to be compatible with slow conventional freezing.



In our lectures we have often mentioned that there is a simplified point of view that vitrification is the solidification without formation of crystals. Extending this description, one could say that vitrification is solidification of vitrifying solution without formation of hexagonal (big, lethal) intracellular structures by extreme elevation in viscosity during cooling. Obviously, thereby vitrification appears beneficial in terms of avoiding cryo-injuries traditionally associated with the formation of intracellular ice. Therefore we developed and for the first time reported (V. Isachenko et al., 2011d) the vitrification methodology where a relatively large volume of spermatozoa suspension can be frozen in one cooling pocket (straw). Vitrification medium described here does include sucrose (Isachenko et al., 2008). As a rule, in routine practice the carbohydrates are the standard part of any cryoprotective solution. They are used for spermatozoa cryopreservation to compensate osmotic effects caused by the permeable cryoprotectants and do play an important role as an additional dissolving, membrane stabilizing and dehydrating agents (Wakayama et al., 1998). Therefore, sucrose can be considered as a natural cryoprotectant, lacking most of toxic properties of permeable cryoprotectants. Human spermatozoa can be successfully frozen in the absence of permeable cryoprotectants, using protein- and sugar-rich extracellular non-permeable cryoprotectants (Koshimoto et al., 2000; Karlsson and Cravalho, 1994). The ability of sucrose to prevent the artificial induction of membrane damages and acrosome reaction during vitrification/warming (Isachenko et al., 2008) corroborated our previous conclusions that the inclusion of sucrose in combination with human serum albumin in the vitrification medium has a visible cryoprotective effect.

In our study (Isachenko et al., 2011d) we reported for the first time a novel technology of aseptic 'cryoprotectant-free' vitrification of human spermatozoa in large volumes. It allows:

1. to obtain 0.5 mL of spermatozoa suspension, free both from seminal plasma (because of swim up procedure preceding vitrification) and free from additives which are part of conventional freezing procedures;
2. to cryopreserve spermatozoa, which are ready for further use immediately after thawing without any additional treatment (centrifugation, separation in the gradient, removal of cryoprotectant and others).

The technology includes:

- cryoprotective medium with only non-permeable cryoprotective agents (0,25 M sucrose in end concentration and 1% human serum albumin). As basal medium is the Human Tubal Fluid (Quinn et al., 1985).
- the end-concentration of prepared for vitrification spermatozoa is  $5 \times 10^6$  spermatozoa / mL. It is possible to vitrify the different concentrations of prepared spermatozoa without influence on warming results (non-published data).
- using of 0.5 mL plastic straws with subsequent sealing from both side before cooling in liquid nitrogen.
- The warming up of spermatozoa is achieved by immersing straw with vitrified spermatozoa into warmed water bath at 42°C.

### **Technological procedure, shortly**

*Vitrification.* Prior to vitrification, spermatozoa were processed by swim-up technique with subsequent dilution with cryoprotectant medium according to Isachenko (Isachenko et al.,

2008). Diluted suspensions were maintained at room temperature for 5 minutes before the cooling procedure. The packaging of spermatozoa for aseptic vitrification was performed in the following way. Spermatozoa suspensions were cooled in 0.5 mL plastic CBS straws (CryoBio System, Paris, France) (Figure 6). The straw was labeled with asterisk (1 cm from the inner end of cotton-polyvinyl plunge, arrows on Figures 6a-g). The straw was filled up to asterisk with 0.5 mL of spermatozoa suspension by aspiration (Figure 6a). Then the filled straw was expelled from the tube while aspiration of air continued. Subsequently, when the suspension reached the polyvinyl plunge, the polymerization of polyvinyl was initiated due to humidification. After aspiration was completed, and the top end of straw was sealed by polymerized polyvinyl, straw was hermetically heat-sealed at both sides using flame of alcohol burner and forceps (Figures 6b,e). The hermetically sealed straw with spermatozoa was allowed to cool briefly (~ 2 seconds). This procedure ensured that spermatozoa at any time were not in contact with the heat-sealing area. Alternatively, any commercial equipment (with exception of ultrasound equipment) could be used for thermo-hermetic sealing. The straws were immersed into liquid nitrogen in horizontal position (approximately for 8 seconds) (Figure 6c) and stored there at least for 24 hours before use.

*Warming.* The warming up of spermatozoa is achieved by immersing straw with vitrified spermatozoa into water bath at 42°C and dangling it gently in water for 20 seconds (Figure 6 d). After warming, the residual fluid was removed from the straw with paper towel, and straw disinfected with 70% ethanol. The heat-sealed part of straw (opposite to the cotton-polyvinyl plunge) was cut off with sterile scissors, and the aspirator was connected with the straw (Figure 6f). A low differential negative pressure was applied by aspiration. That ensured that after subsequent cutting of the cotton-polyvinyl plunge fluid was not leaking out (Figure 6f). Finally, the suspension was expelled from the straw (Figure 6g) for immediate evaluation of sperm quality, loading into catheter and intrauterine insemination.

The results were compared to slow frozen spermatozoa. For this purpose the Freezing Medium TYB, IrvineScientific, with 12 % (v/v) glycerol and 20 % (v/v) egg yolk were used. The suspension of swim up-prepared spermatozoa was 1:2 diluted with freezing medium (to achieve the concentration of  $0.5 \times 10^6$  spermatozoa / mL and equilibrated at room temperature for 10 minutes then the 500  $\mu$ L of spermatozoa suspension was packaged into 0.5 mL plastic straws (Cryo Bio System, Paris, France), the straws were sealed from both sides, kept in horizontal position at 4 °C for 30 minutes and put in the horizontal position into liquid nitrogen vapor (-80 °C, 10 cm over liquid nitrogen surface), kept for 30 minutes and finally placed into liquid nitrogen where they were stored minimum 24 hours until evaluation. For thawing of samples, the straws were taken from liquid nitrogen, hold in air for 30 seconds, immersed into 37°C water bath in horizontal position and hold in this bath for 20 seconds until ice melted. After thawing, 10 mL of basic (HTF-HSA) medium was added to thawed sample and centrifuged for 5 minutes at 340g. The supernatant was removed and pellet resuspended with the same basic medium in order to obtain a final concentration of  $0.5 \times 10^6$  spermatozoa/mL. The changes in following physiological and morphological parameters of thirty minutes after warming of fresh, vitrified and conventional frozen spermatozoa were investigated for progressive motility (WHO, 1999); cytoplasmic membrane integrity (CMI) with applying of a LIVE/DEAD sperm viability kit, which is used to stain nucleic acid probe molecular (SYBR-14 dye) and propidium iodide (IP) and Acrosomal membrane integrity (AMI). The acrosome-reacted, and capacitated spermatozoa were detected using the double fluorescence chlortetracycline (CTC)-Hoechst

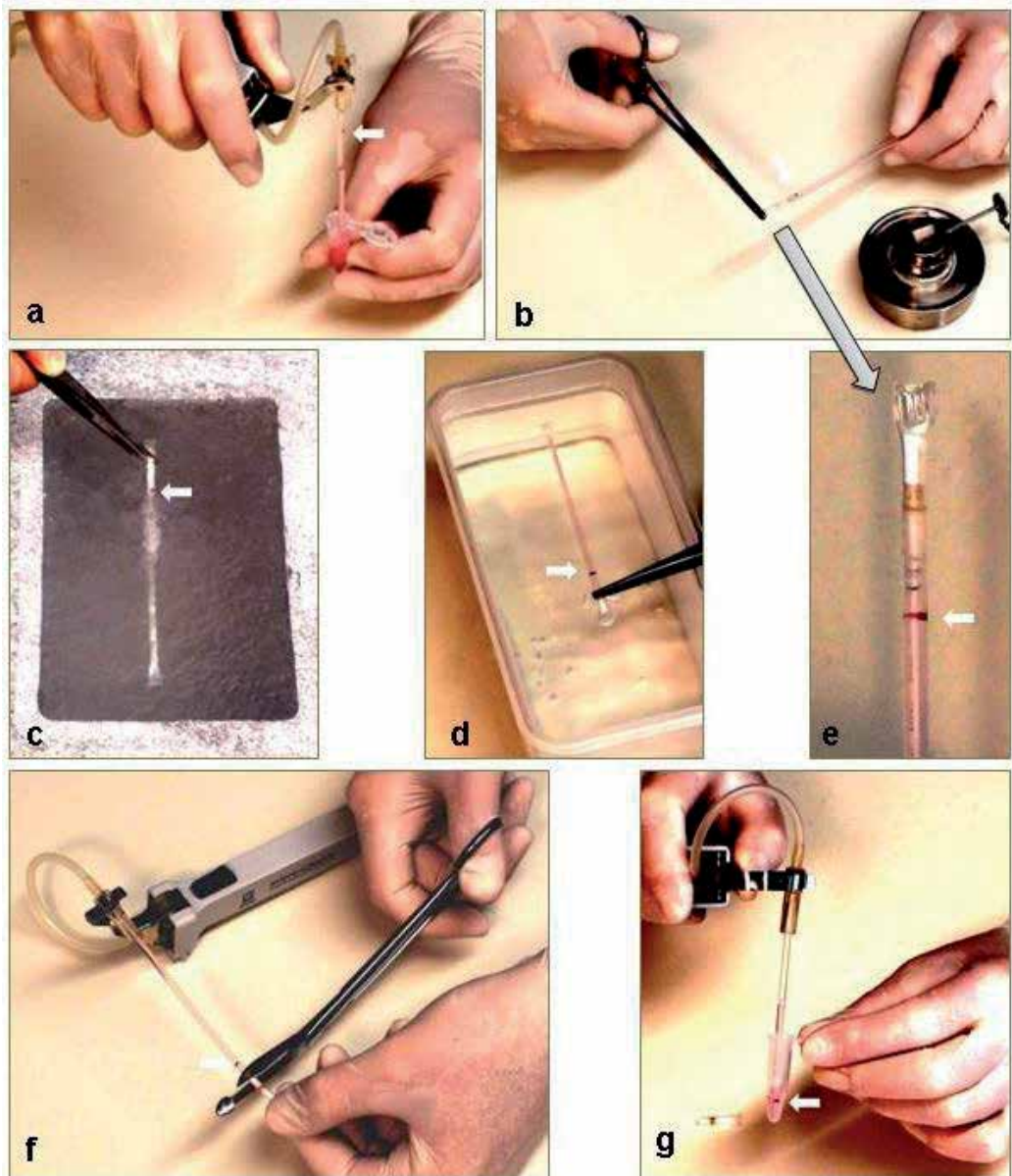

(Arrows) line, (a) aspiration of spermatozoa suspension in straw, (b, e) flame-sealing of straw, (c) cooling of straw, (d) warming of straw, (f) cutting of straw, (g) expelling of spermatozoa suspension from straw.

Fig. 6. Schema of human spermatozoa vitrification using 0.5 mL straws.

33258 staining technique (Kay et al. 1994). The results of that comparative investigation have shown that motility of spermatozoa vitrified in large volume (500  $\mu$ L) in absence of permeable cryo-protectants displayed statistically higher levels of motility as compared to slow conventional freezing (76.0  $\pm$  4.7 % *vs* 52.0  $\pm$  3.9 %, respectively,  $P < 0.05$ ; in fresh 85.0  $\pm$

5.1%) as well as after 24 and 48 hours in vitro culture (Figure 7). It was observed, that higher rates of membrane integrity (Figure 8) were achieved in vitrified sperm as compare to slow conventional freezing ( $54.0 \pm 5.0\%$  vs  $28.3 \pm 3.5\%$ , respectively,  $P < 0.05$ ), but lower then in non-treated fresh control ( $98.2 \pm 0.5\%$ ,  $P < 0.05$ ). The effect of two procedures used for cryopreservation on sperm functional state as assessed by CTC staining is shown on Figure 8. There was a statistically significant difference between percentages of spermatozoa with intact acrosome after vitrification as compared to conventional freezing ( $44.4 \pm 4.5\%$  vs  $30.0 \pm 3.9\%$ , respectively,  $P < 0.05$ ), but statistically lower then in fresh non-treated samples ( $95.4 \pm 5.0\%$ ;  $P < 0.05$ ). There were no statistically significant difference between percentages of sperm identified as 'capacitated' in CTC staining after vitrification as compared to conventional freezing ( $10.0 \pm 1.8\%$  vs  $11.0 \pm 1.1\%$ , respectively,  $P < 0.01$ ), but significantly higher in fresh non-treated control ( $4.0 \pm 0.2\%$ ,  $P < 0.05$ ). Described technology has a massive potential for applications in reproductive assisted procedures (ICSI, IVF and IUI) not only because of its simplicity but also because this procedure can effectively protect these cells from cryo-injuries, at a level at least comparable to conventional freezing as judged by basic parameters of spermatozoa quality.

This cryoprotectant-free vitrification technology for the cryopreservation of spermatozoa instead traditional slow freezing with permeable cryoprotectants is already used in following centers: our university maternal hospital ([www.uniklinik-ulm.de](http://www.uniklinik-ulm.de)): IVF Centers in Temuco, Chile (about 200 IUI cycles/year) and in Ulm, Germany ([www.kinderwunsch-ulm.de](http://www.kinderwunsch-ulm.de)) (about 1,000 IVF cycles/year). First successful pregnancies and birth of healthy babies after insemination of vitrified spermatozoa has been recently achieved with vitrified spermatozoa (Isachenko et al., 2011d; Sanchez et al., 2011a).

In conclusion, a basic protection from cryo-injury can be achieved for human spermatozoa using the novel technology of aseptic cryoprotectant-free vitrification in large volumes.

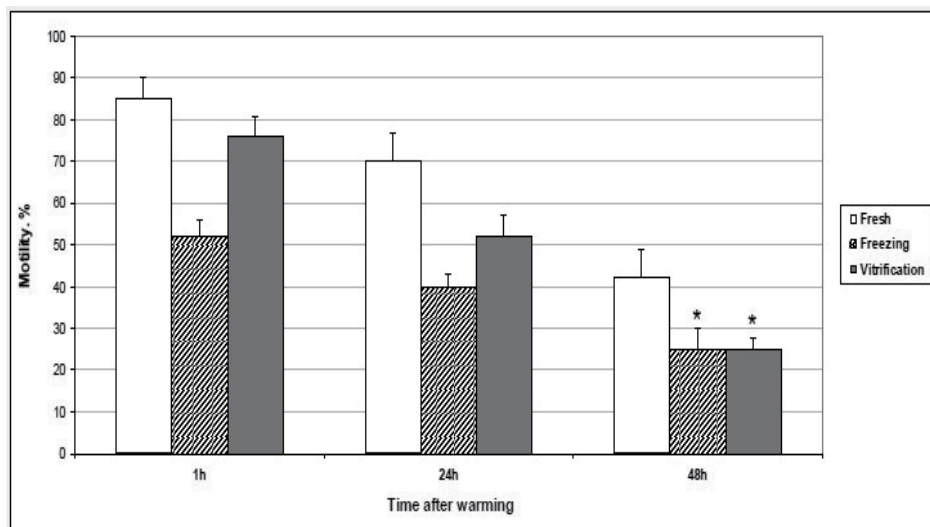

All rates in respective groups are significantly different ( $P < 0.05$ ) instead columns marked with asterisks ( $P > 0.1$ ).

Fig. 7. Motility of human spermatozoa after conventional freezing and vitrification.

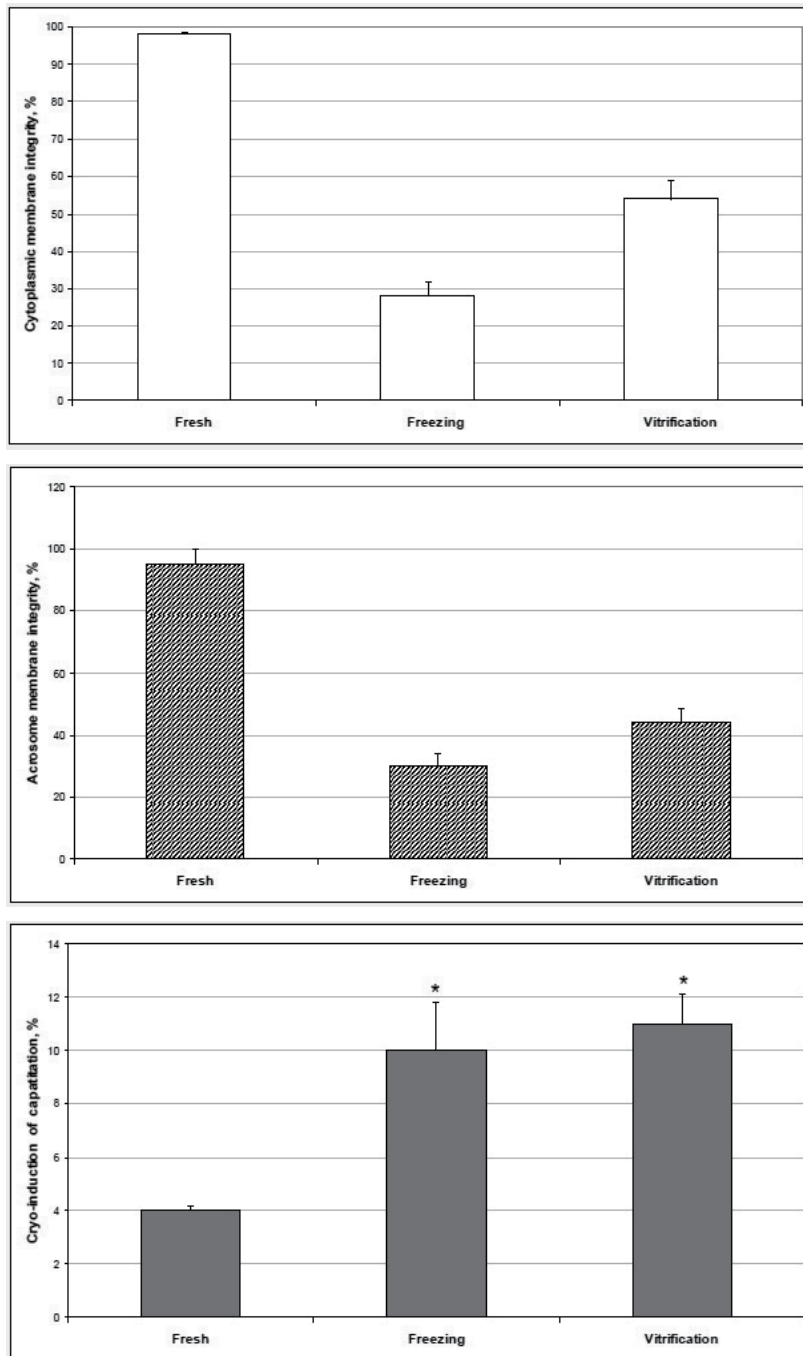

All rates in respective groups are significantly different ( $P < 0.05$ ) instead columns marked with asterisks ( $P > 0.1$ ).

Fig. 8. Cytoplasmic and acrosomal membranes integrity as well as cryo-induction of capacitation of human spermatozoa after conventional freezing and vitrification.

#### 4. Technology for vitrification of dog spermatozoa (Sánchez et al, 2011)

If we will investigate the history of reproductive cryobiology we will see that all routine-used technique, excluding intracytoplasmic sperm injection, was firstly approved on the animal model. The same happened and with vitrification technique. After first promising investigation with frog (Luyet and Hodapp, 1938), human (Jahnel, 1938; Parkes, 1945) fowl (Schaffner, 1942) and human, and rabbit (Hoagland and Pincus 1942) spermatozoa the vitrification technique was successful re-discovered in 2002 (Nawroth et al., 2002) on human spermatozoa. Recently we have decided to extrapolate the results of our investigation on animal model, thus we have with high attention examined the work of Watson and Plummer (Watson and Plummer, 1985) about responses of spermatozoa from different kind of animals to cold shock. According to this work most sensitive to cold injury are spermatozoa of animals, which produce gametes with big blade-shaped flat head. The spermatozoa of human, stallion, dog and cat have the highest stability to cold shock due to smallest blade-shaped flat head compare to the rabbit spermatozoa (have middle stability), ram, bull and boar (have the lowest stability to cold shock). Took into account these data we have decided, that the spermatozoa from human, stallion, dog and cat could be similar well preserved using vitrification technique. In this case we have decided to investigate the ability of dog spermatozoa, which stay on third place after human one according to head's size, to maintain their physiological function after vitrification without use of permeable cryoprotectants. In cryobiological routine practice, carbohydrates were already used for sperm cryopreservation (Nakagata, Takeshima, 1992, 1993; Wakayama et al., 1998). It has been suggested that raffinose plays the role of a membrane stabilizing and dehydrating agent. Comparative investigation of three different sugars, monosaccharide glucose, disaccharide sucrose and trisaccharide raffinose, showed that protection against freezing/thawing injuries is independent of the kind of sugar itself, but depends more on the sugar's concentration (Koshimoto & Mazur, 2002). Based on this evidence, we have decided to investigate the different concentrations of sucrose on the viability of cryopreserved spermatozoa. However, the problem was that the dog spermatozoa have the special physiological property which connect to capacitation process. It is well known that spermatozoa of different kind mammalian species are very sensitive to the negative effect of cryoprotectants dependent on temperature (Sánchez & Schill, 1991; Deppe et al., 2004). It is also proved (Pérez et al., 1996) that low survival and fertilizing capacity of cryopreserved mammalian spermatozoa has been attributed to an early state of capacitation resulting from the procedures by which spermatozoa are preserved. These kind of changes have been called as '*early state capacitation*' or '*cryocapacitation*'. These data of Pérez and colleagues (Pérez et al., 1996) later were supported (Samper, 1997; Maxwell et al., 1997). These authors showed the negative effect of cryocapacitation on the fertilizing capacity and viability of spermatozoa. The described study showed that the canine spermatozoa starts rapidly with capacitation process as soon as have been separated from seminal plasma with subsequent 20–40% of capacitated and spontaneous acrosome reacted spermatozoa in culture media. This rate is higher than in other mammals (Risopatrón et al., 2002; Santiani et al., 2004) and the spermatozoa are therefore more affected by the cryocapacitation process than those of other species. Probably the sperm membrane in this species is especially sensitive to cooling in the range of temperatures between 20°C and 5°C and to heating to 30°C at thawing (Holt & North, 1991; Sánchez & Schill, 1991). In this case for dog spermatozoa which are high sensitive to capacitation the cryopreservation protocol with a very increased cooling speed should be used, because these temperature ranges by ultra-rapid freezing (vitrification) will be just eliminated.

Took into account all mentioned above in our investigation (Sánchez et al., 2011b) to decrease the sensitivity of dog spermatozoa to different manipulations before cryopreservation we have chosen the Human tubal fluid (HTF, Quinn et al., 1985) as basic medium, which was served as control. The centrifugation for removing seminal plasma before dilution with cryoprotective media and subsequent cryopreservation at 700 g for 6 min was performed. This allowed us to achieve very high (~ 80%) amount of spermatozoa with intact acrosome in control.

(Figure 9). Integral membrane proteins are associated with the lipid bilayer and their function may be expected to be altered, especially those that perform the function of transport channels for calcium absorption. The permeability of these channels is increased on cooling, affecting calcium regulation (Robertson & Watson, 1986; Robertson et al., 1988). These facts have serious consequences for cell function (Bailey & Bhur, 1994) and many changes may be incompatible with sperm viability. In this case we have decided to apply to dog spermatozoa the early developed us vitrification protocol (Isachenko et al., 2008) for human sperm cells. The following tested groups were compared: HTF (Control); HTF-bovine serum albumin (BSA, 1% end-concentration); HTF-BSA + 0.1 M sucrose; HTF-BSA + 0.25 M sucrose and HTF-BSA + 0.4 M sucrose.

The vitrification procedure was done as follow. Briefly, aliquots of 30  $\mu$ l of sperm suspension (different vitrification media) were dropped directly into LN<sub>2</sub>. After solidification, the spheres were packaged in cryotubes and stored for at least 24 h in liquid nitrogen before use. The warming was performed by quickly submerging spheres one by one (not more than five spheres) in 5 ml of HTF-BSA 1% pre-warmed to 37°C accompanied by gentle agitation for 5–10 sec. The post-thaw sperm suspension was maintained at 37°C and 5% CO<sub>2</sub> for 10 min and then centrifuged at 300 g for 5 min. The cell pellet was finally re-suspended in 50  $\mu$ l of HTF only for sperm evaluation.

The influence of tested media on the following physiological parameters of dog spermatozoa we have checked with such screening methods: viability and condition of acrosome with double stain technique (Trypan blue–Giemsa) with subsequent evaluation of acrosome pattern according to Didion (Didion et al., 1989); DNA fragmentation was detected with using of TUNEL technique (Gorczyca et al., 1993); detection of the change in mitochondrial permeability was done according to Smiley (Smiley et al., 1991); the motility of spermatozoa was checked as well.

According to our investigation the percentage of spermatozoa with acrosome-intact membrane was high in all treatment groups (Figure 9) independent from concentration of sucrose in vitrification solution, but lower then in control ( $P < 0.05$ ).

The best progressive motility after warming (Figure 10) was significantly increased in the sperm vitrified with 0.25 M sucrose and 1% BSA ( $42.5 \pm 2.3\%$ ), compared to other treatment groups ( $P < 0.01$ ). However, lower or higher concentration of sucrose did not significantly improve the progressive motility post-vitrification. Comparable results (60.7% of motility) was reported (Tsutsui et al., 2003) when the dog semen was chilled in egg yolk–\*\*Tris at 4°C for over 4 days, but the spermatozoa lost their fertilizing capacity.

The presence of sucrose in vitrification solution independent from the concentration has strong positive influence on viability of spermatozoa (Figure 10) and was ~70% ( $P < 0.001$ ) for all sucrose-treatment groups.

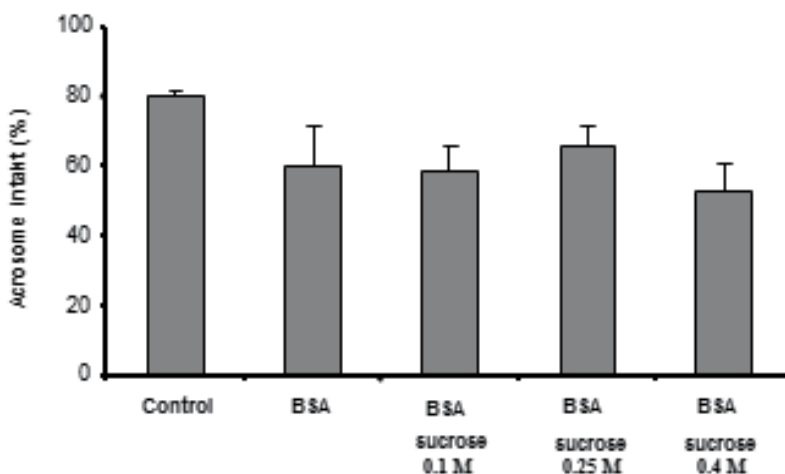

Fig. 9. Acrosome intact in canine spermatozoa after vitrification with 1% BSA and different concentrations of sucrose. Percentage of acrosome intact spermatozoa was determined by dual stain (Trypan blue- Giemsa). Data are expressed as mean  $\pm$  SD from six experiments. Control = Sperm vitrified with medium HTF only. BSA, bovine serum albumin.

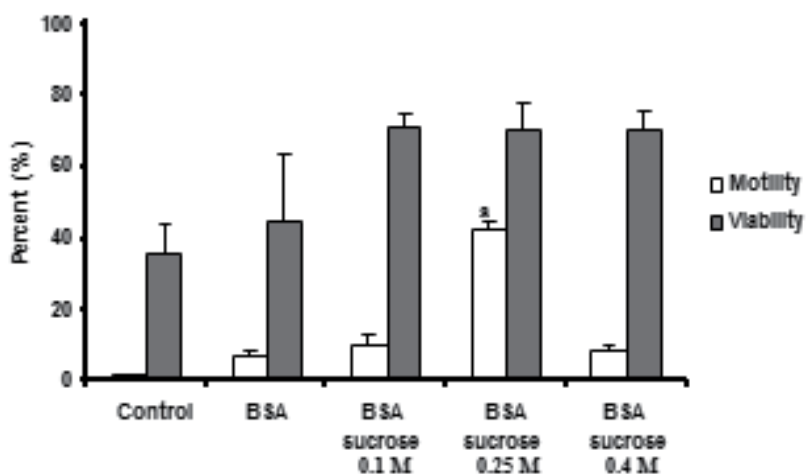

Fig. 10. Progressive motility and viability of canine spermatozoa after vitrification with 1% BSA and different concentrations of sucrose. Motility was determined by microscopic examination using a phase contrast microscope and viability by dual stain (Trypan blue- Giemsa). Data are expressed as mean  $\pm$  SD from six experiments. A significant difference with respect to the control is indicated by a (\*) ( $P < 0.01$ ). Control: Sperm vitrified with medium HTF only. BSA, bovine serum albumin.

Our data have shown that the vitrification significantly protect the sperm DNA (Figure 11) against fragmentation when used 0.25 M sucrose in combination with 1% BSA compare to control ( $97,2 \pm 0,5\%$  vs  $94,4 \pm 0,6\%$ , respectively,  $P < 0,05$ ). However, the lower (0.1 M) as



well as higher concentrations (0.4 M) of sucrose had not significantly protective effect against DNA fragmentation. These data support our previous results (Isachenko et al., 2004a, b, the vitrification medium included only 1% HSA) and we can assume that vitrification itself due to very fast speed of cooling can provide protective effect on DNA and protect against fragmentation. It is very important results, because damage of DNA in sperm is strongly correlated with mutagenic events (Moreno et al., 2004) and how have showed Paasch with colleagues (Paasch et al., 2004) cryopreservation and thawing can be associated with varying extent of activation of apoptotic machinery in human spermatozoa. The danger is that such spermatozoa are still able to fertilize the oocyte, however, the mutations and defects did not possible to discover until the embryo has divided and the fetus has developed (Twigg et al., 1998). At present exist the opinion that DNA decondensation or fragmentation may occur in different magnitudes, which will depend on the process or the kind of cryoprotectant used (Schuffner et al., 2001; Chohan et al., 2004; Ngamwuttivong & Kunathikom, 2007; Yildiz et al., 2007). Unfortunately, until now this question is still open, because it is not entirely clear what the effect of cryopreservation on DNA integrity is, and what would be the ideal conditions of slow freezing to reduce this effect. In this case the method of vitrification is more successful, because allows to obtain low levels of DNA fragmentation by protection due to applying of very high speed of cooling and exclusion of permeable cryoprotectants from vitrification solution.

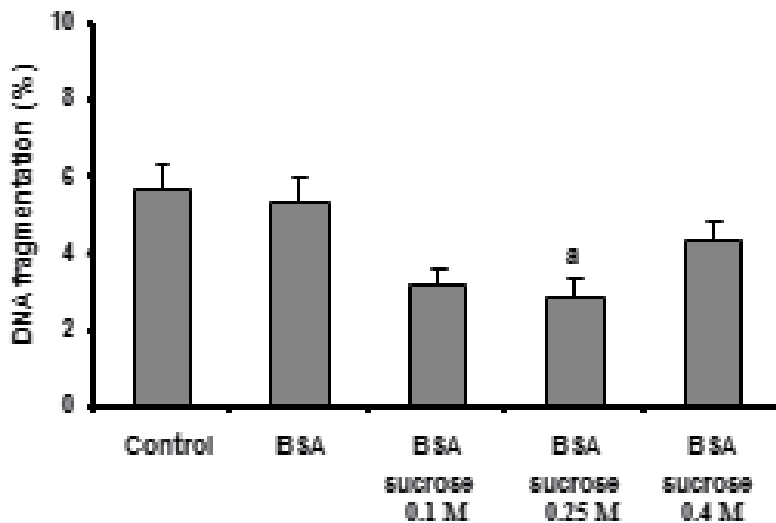

Fig. 11. DNA fragmentation in canine sperm after vitrification with 1% BSA and different concentrations of sucrose. DNA fragmentation was determined by the TUNEL assay. Data are expressed as mean  $\pm$  SD from six experiments. A significant difference with respect to the control is indicated by a ( $P < 0.05$ ). Control: Sperm vitrified with medium HTF only. BSA, bovine serum albumin.

Fragmentation DNA has been interpreted at present as apoptosis or apoptosis-like events (Paasch et al., 2004). This has been verified in cryopreserved / thawed sperm, with presence of increased caspase's activity induced by cryopreservation (caspase-3, -8, -9), decreased  $M \Delta\Psi$  due to release of regulating proteins associated with mitochondria, evidence of DNA

fragmentation, externalization of phosphatidylserine in the plasma membrane (Paasch et al., 2004) and production of reactive oxygen substances (Roca et al., 2005). Among the first events that occur in early apoptosis are changes in mitochondrial permeability which alter the transmembrane potential ( $M \Delta\Psi$ ). Changes in the  $M \Delta\Psi$  are caused by the insertion of proapoptotic proteins within the membrane, and oligomerisation may create pores, dissipating the transmembrane potential and thus releasing cytochrome c into the cytoplasm (Zamzami et al., 1995). In our work (Figure 12) we achieved the reduction of apoptotic-like process in canine spermatozoa and have got after warming more than 40% of spermatozoa with intact  $M \Delta\Psi$  using of the vitrification solution with 0.25 M sucrose and 1% BSA compare to other treatment groups ( $P < 0.001$ ).

These results have demonstrated that vitrification without the use of permeable cryoprotectants allows to avoid the cryoprotectants toxicity caused by their addition and removal with subsequent negative effects on the spermatozoa genome. The use of sucrose in concentration of 0.25 M in combination with 1% BSA and ultrarapid speed of cooling can effectively preserve important physiological parameters of canine spermatozoa.

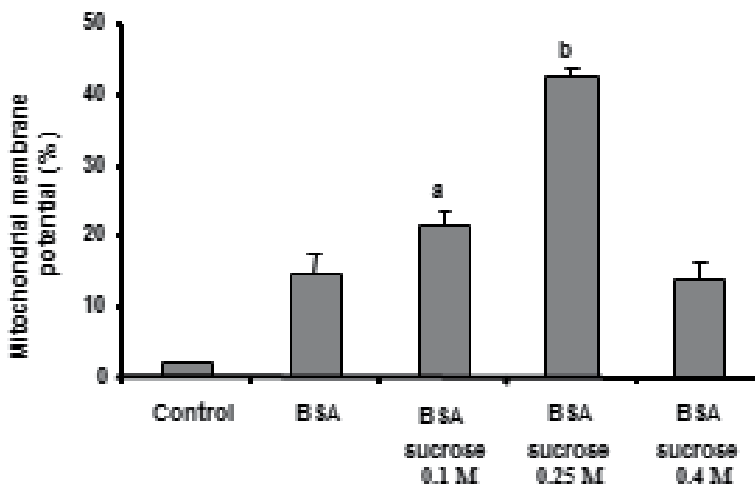

Fig. 12. Integrity of mitochondrial membrane potential in canine spermatozoa after vitrification with 1% BSA and different concentrations of sucrose. Mitochondrial membrane potential was determined by staining with the cationic fluorescent JC-1. Data are expressed as mean  $\pm$  SD from six experiments. A significant difference with respect to the control is indicated by a ( $P < 0.05$ ) and b ( $P < 0.01$ ). Control: Sperm vitrified with medium HTF only. BSA, bovine serum albumin.

## 5. New technology for vitrification of fish (*Oncorhynchus mykiss*) spermatozoa Merino et al., 2011a, b.

At the beginning of this sub-chapter we would like to mention that the fish spermatozoa of both sea and river fish species have a very special peculiarities compare to all mammalian species. The fish sperm cells are homogenous; all spermatozoa can be activated at the same time and then swim with very similar characteristics at a certain time point post-activation. In many fish species, the flagellum is 50–60  $\mu$ m long with a ribbon shape (presence of fins)

instead of cylindrical; thus, the flagellum appears brighter by dark-field microscopy, allowing clear visualization of wave shapes (Cosson et al. 2008). Just for knowledge, the head of investigated rainbow trout spermatozoa is ovoid-shaped, measuring about  $3 \times 1.3 \mu\text{m}$  in diameter and possess any acrosome. In middle piece present only one mitochondrial body (several mitochondria are sometimes identified in the middle piece, but later during evolution they are fused together) is shaped like an incompletely closed ring. The middle piece is completely separated from the flagellum by an invagination of the cell membrane, which reaches from the head to the base (Billard, 1983; Tuset et al., 2008). During spermatogenesis, sperm cells are prepared for accomplishing their fertilizing task for which they need to fully exploit their swimming ability immediately and as fast as possible in order to encounter the egg. The initial velocity is very high at activation, but motility duration lasts for periods ranging only 40 s to 20 min as an energetic consequence of the high velocity (Cosson et al. 2008). As possible to see the fish spermatozoa are much different from mammalian one.

Since the first successful cryopreservation of herring sperm 50 years ago (Blaxter, 1953) considerable improvement has been achieved in sperm cryopreservation and developed technology of conventional freezing of fish spermatozoa has been used in agricultural practice very broadly (Scott and Baynes, 1980; Stoss and Holtz, 1981; Dreanno et al., 1997; Wheeler and Thorgaard, 1991; Conget et al., 1996; Lahnsteiner et al., 2000; Fabbrocini et al., 2000; Zhang et al., 2003; Chen et al., 2004; Viveiros and Godinho, 2009). Usually, for protection of spermatozoa from the negative effects of low temperatures caused by conventional freezing ('slow', with controlled rate of cooling), permeable cryoprotectants are used. At present, applied cryobiology practically always uses only four permeable cryoprotectants: three spirits (ethylene glycol, propylene glycol and glycerol) and the highly polarized organic solvent dimethyl sulfoxide. However, as reported for mammalian spermatozoa, these cryoprotectants can produce osmotic and cytotoxic effects, including parthenogenesis (Gilmore et al., 1997). And for fish spermatozoa these problems are still very actual, because post-thaw viability and fertility of the cryopreserved sperm are reduced dramatically as a result of accumulated cellular damage that arise throughout the freezing-thawing process. The same like for other species the cryopreservation results in considerable damage to cellular structures such as plasma membrane, nucleus, mitochondria, and flagellum (Lahnsteiner et al., 1992; 1996; Drokin et al., 1998; Conget et al., 1996; Zhang et al., 2003). So, according to Ogier de Baulny (Ogier de Baulny, 1997) the percentage of spermatozoa with an intact membrane and a functional mitochondrion after cryopreservation varied below 18% only. According to our results which we have achieved on human spermatozoa (Isachenko et al. 2003, 2004a,b, 2005, 2008, 2011a, b, c, d) and dog (Sánchez et al., 2011b) with applying of cryoprotectant-free vitrification protocol we have decided to investigate the method on fish spermatozoa (*Oncorhynchus mykiss*) (Merino et al., 2011a, b). This decision we have got because the authors of these studies were able to establish statistically higher motility and in vitro fertilization ability of vitrified spermatozoa compared with spermatozoa cryopreserved using conventional slow freezing.

The standard Cortland® culture medium (Trus-Cott et al., 1968) for fish spermatozoa (per liter: 1.88 g NaCl, 0.23 g CaCl<sub>2</sub>, 7.2 g KCl, 0.41 g NaH<sub>2</sub>PO<sub>4</sub>, 1 g NaHCO<sub>3</sub>, 0.23 g MgSO<sub>4</sub> · 7 H<sub>2</sub>O, 1.0 g Glucose, 10% Glycol and 10% Tris Base and prepared to pH 8 at 268mOsm) was used for all manipulation and served as control. Fresh-retrieved semen was diluted 1:3 in the non-activating Cortland® medium with subsequent determination of the motility and concentration by phase-

contrast microscopy. Subjective evaluations of motility were performed by placing 2 $\mu$ l of this sperm suspension on a glass slide and immediately adding 10 $\mu$ l of the activator Powermilt® (Católica de Temuco University, Chile) at 10°C. The motility of the spermatozoa was observed in 12 $\mu$ l sperm activated by subjective microscopic examination under phase contrast optics at 400x magnification. Motility assessments were made in triplicate for each sample at 5 s following activation with Powermilt®. Sperm concentrations were determined with a Neubauer hemocytometer after dilution of 1 $\mu$ l of sperm suspension in 1200 $\mu$ l of standard culture medium. Only samples with high motility (>80%) and concentration 12 $\times$ 10<sup>9</sup> spermatozoa/mL (Drokin et al., 1998) were used in this study.

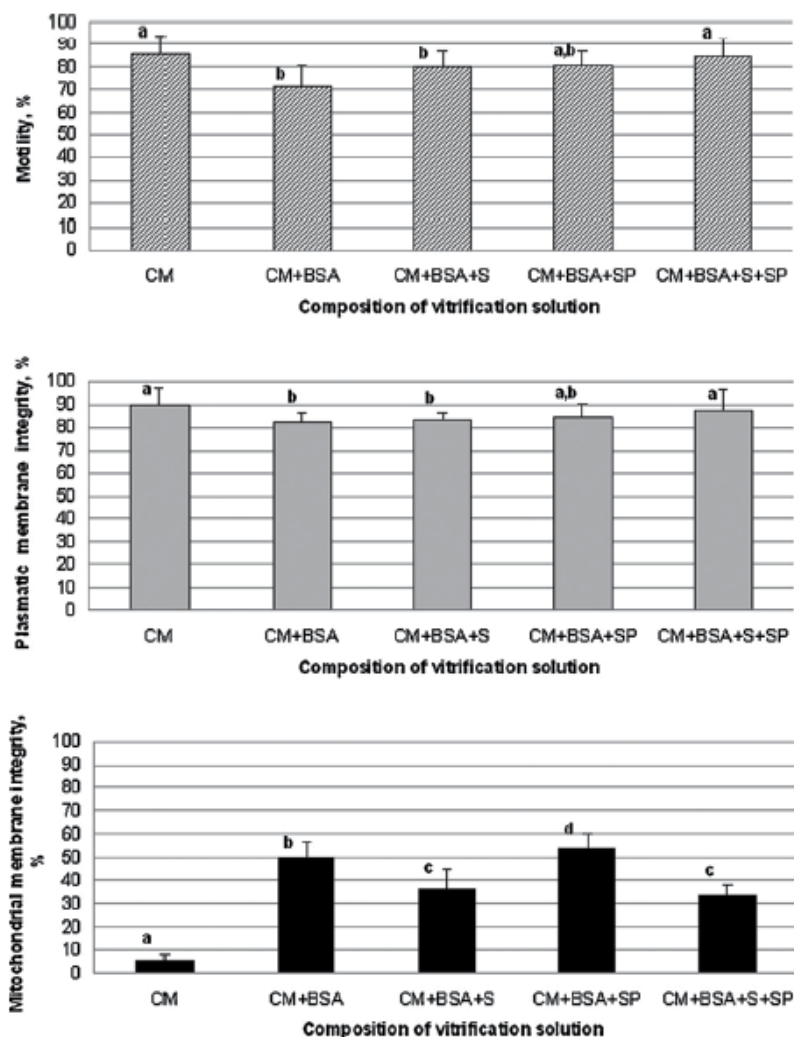

Fig. 13. Motility, cytoplasmic membrane integrity and mitochondrial membrane integrity of vitrified rainbow trout spermatozoa. (CM) Cortland®, (BSA) 1% bovine serum albumin, (SP) 40% of seminal plasma, (S) 0.125 M sucrose. Different superscripts indicate statistical difference between respective values of compared groups ( $P < 0.05$ ).

In our work we have investigated the following five treatments groups (Figure 13):

**Group 1:** Cortland® medium only (frozen control)

**Group 2:** Cortland® medium+ 1% BSA

**Group 3:** Cortland® medium+ 1% BSA + 0.125M sucrose

**Group 4:** Cortland® medium+ 1% BSA + 40% seminal plasma

**Group 5:** Cortland® medium+ 1% BSA + 40% seminal plasma + 0.125M sucrose.

The vitrification /warming of rainbow spermatozoa was proceeded as following:

Sperm samples were centrifuged at 300 g for 10 min at 4 °C. The seminal plasma (supernatant) was retained and the sperm suspension diluted with Cortland® medium to a concentration of  $40 \times 10^6$  spermatozoa/ml. Five equal 500- $\mu$ l aliquots from each preparation were placed in individual 1ml tubes for vitrification. Twenty microliters of sperm suspension from each tube was dropped directly into liquid nitrogen, during which the droplet adopted a spherical form approximately 3mm in diameter. After 5min, the solidified droplets were placed into 2-ml cryovials pre-cooled in liquid nitrogen with precooled tweezers. After storage for at least 24 h in liquid nitrogen, the samples were warmed by plunging the droplets into a 15ml tube containing 5ml Cortland® medium supplemented with 1% BSA at 37°C with intense agitation. After warming (one droplet/tube), the tubes were maintained at 37°C for 5–10 min prior to evaluation of spermatozoa quality.

The spermatozoa quality was tested according the following parameters:

- Motility - (percent of motile spermatozoa detected during 30 s after warming) was performed using phase contrast microscope (Carl Zeiss Jena, Jena, Germany);
- Cytoplasmic membranes integrity was assessed using the LIVE/DEAD Sperm Viability Kit (SYBR-14 dye; Invitrogen Inc., Eugene, OR, USA) and propidium iodide. The analysis of spermatozoa was carried out under an epifluorescence microscope (Axiolab drb KT 450905, Zeiss) at 400x magnification (Figure 14).
- Mitochondrial membranes integrity (mitochondrial activity) was assessed due to relative levels of  $\Delta\Psi$  using the fluorescent cationic dye, JC-1 (5,5',6,6'-tetrachloro-1,1',3,3'-tetraethylbenzamidazolocarboxyanin iodide, according to the manufacturer's protocol (MIT-E- $\Psi$ , BIOMOL® International LP, Plymouth Meeting, PA, USA) and observed under epifluorescent optics (Axiolab drb KT 450905) at 400x magnification at room temperature. For the MIT-E- $\Psi$  reagent, an excitation/emission filter of 488/490nm was used. The monomeric dye structure emits at 527nm (Green FITC channel), whereas J-aggregates indicative of high potential of undamaged mitochondria emit at 590nm (red, RITC channel). If  $\Delta\Psi_m$  is above a certain mV threshold, JC-1 monomers multimerize into a crystalline-like state that shifts the emission spectrum to higher frequencies (orange-red) and it is the multimerization of the monomer that is potential sensitive, the paracrystals can be stable after formation, which is why we can still get red fluorescence in JC- 1 treated cells after collapsing  $\Delta\Psi_m$  with inhibitors, which is why staining is done after inhibitor treatment (Figure 15).

To investigate these cold sensitive (Holt, 2000; O'Connell et al., 2002) organelles of spermatozoa were necessary because the retention of plasma membrane integrity and

mitochondrial function after cryopreservation is too important with regard to fertilization capacity of both spermatozoa and oocytes (Gao et al., 1997; de Lamirande et al., 1997). For all species, normal mitochondrial function is a key factor in the fertilizability of spermatozoa and for fish it is especially critical to maintain mitochondrial activity because high motility normally lasts for only 30 s to few minutes. Spermatozoa of rainbow trout have only one mitochondrion to produce sufficient ATP to drive this transient high motility, and damage during cryopreservation will certainly lead to decrease of motility and as a result, fertilization ability (Maise, 1996). In this case the stability of mitochondrion during cryopreservation can be used as a specific test for applicability of a any investigated cryopreservation protocol (Meseguer et al., 2004; O'Connell et al., 2002).

The results of this investigation showed that the proportion of sperm showing normal, high motility varied between 82% and 95% in fresh samples. In Groups 1, 2, 3, 4, and 5, motility in these solutions was 86%, 71%, 79%, 81%, and 82%, respectively (Figure 13).

The percent of spermatozoa with intact cytoplasmic membrane after thawing was similar between the 5 experimental groups, ranging from 81.8% to 90%, as shown in Figures 13 and 14. Nevertheless, the integrity of mitochondrial membrane potential of spermatozoa (Figures 13 and 15) in Groups 1, 2, 3, 4, and 5 was decreased significantly compare to non

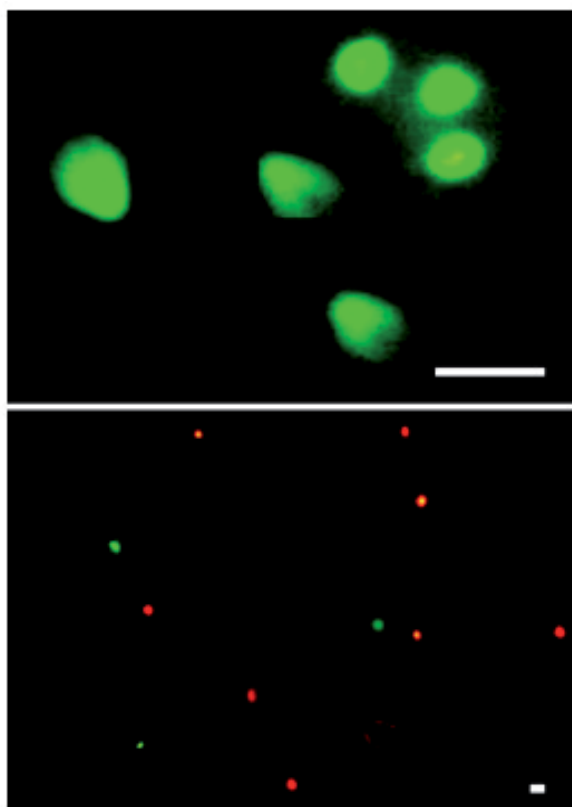

Fig. 14. Example of rainbow trout spermatozoa with non-damaged (green) and damaged (red) cytoplasmic membranes. Bar = 8 $\mu$ m.

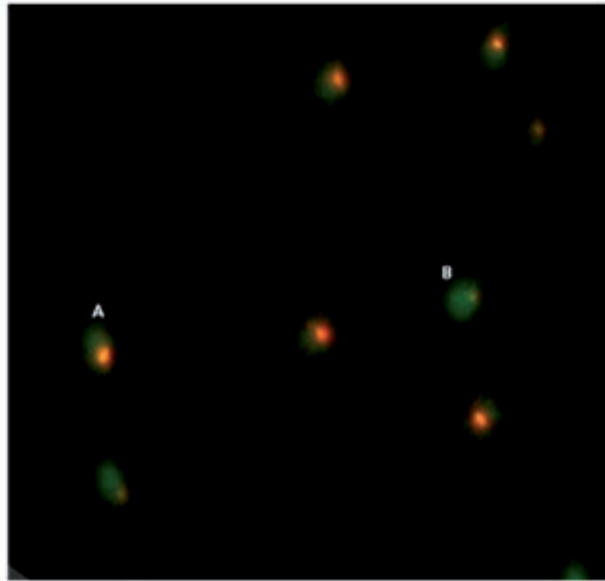

Fig. 15. Example of rainbow trout spermatozoa with (A) non-damaged and (B) damaged mitochondria. Bar = 2.5 $\mu$ m.

treated spermatozoa (5.5%, 49.8%, 37.1%, 54.7%, and 34.4%, respectively). As possible to see from our results they can have the following potential question. How spermatozoa can have a high level of motility with low level of the integrity of mitochondrial membranes? Especially this question is actual taking into account that fish spermatozoa have only one mitochondrion. A lower  $M \Delta\Psi$ , as reflected by green fluorescence, simply can have the following explanation. Activity of the mitochondria, including ATP production, is reduced when compared to their red counterparts. Cell often have “green” and “red” mitochondria with shifts between all green or all red governed by a variety of external and internal conditions, and this is normal. Individual mitochondria constantly shift from red to green and back to red in response to rapid changes in local conditions, including calcium levels and pH (Vanblerkom, personal communication). While the plasma membrane is known to be sensitive to cryopreservation (Cabrita et al., 2001; Aitken and Baker, 2006; Muller et al., 2008), our results shows that it is cryostable in rainbow trout sperm, as indicated by ~90% of non-damaged plasmatic membrane in sperm vitrified in culture medium only i.e., without permeable cryoprotectants and additional proteins). This is similar to levels reported after conventional freezing with permeable cryoprotectants. We suggest that the vitrification technique described here which associated with high rate of cooling allows to avoid the formation of large extracellular water crystals. Sucrose is well known to have a beneficial influence on the plasma membrane of cells subjected to cryopreservation (Anchoroguy et al., 1987; Rodgers and Glaser, 1993). For human spermatozoa, the drop-wise technique of vitrification is a major technical advance because it includes a mixture of non-permeable cryoprotectants such as serum albumin (Isachenko et al., 2008). However, we report that the

inclusion of sucrose in the vitrification solution was ineffective for rainbow trout spermatozoa. According to Lahnsteiner (2007), lipoproteins in the seminal plasma of rainbow trout likely maintain the lipid composition of the plasma and may increase the cryostability of spermatozoa. Our results support this point of view and we suggest that the method of sperm vitrification described here could also be applied to other species. As a rule, carbohydrates are used for sperm cryopreservation to compensate for the decrease in osmotic pressure caused by the permeable cryoprotectant glycerol, which works as an additional solvent and has the ability to decrease the medium's osmotic pressure. Based on this evidence, we investigated whether sucrose had a similar cryoprotective effect on fish spermatozoa during freeze-thaw. We found that its inclusion in vitrification medium has no visible protective effect on mitochondrial membrane integrity nor does it provide significant protection for spermatozoa when compared to other vitrification media containing BSA or BSA + seminal plasma. Indeed, the addition of these non-permeable cryoprotectants did not increase either the motility or plasma membrane integrity of rainbow trout spermatozoa. However, the technology of cryopreservation of fish spermatozoa by direct plunging into liquid nitrogen has a big disadvantage because it did not protect the biological material against direct contact with liquid nitrogen. In this connection in the future investigation it would be necessary to find a synthetic substitute for seminal plasma to avoid the possible microbial contamination. In fact, any technology in reproductive biology, and especially in a therapeutic medical approach, must guarantee the full protection of cells from microorganisms that might survive in liquid nitrogen temperatures (Gardner, 1998; Bielanski et al., 2003), and it has been suggested that liquid nitrogen can be contaminated by microorganisms (Tedder et al., 1995). The problem of potential microbial contamination of spermatozoa during cryopreservation, especially by the virus of Infectious Salmon Anemia is significant in the fish industry, especially in Latin America (Ellis, 2007; Fortt and Buschmann, 2007; Sommer, 2009). In spite of that the results of our experiments conformed that for fish spermatozoa the developed method of cryopreservation by direct plunging into liquid nitrogen (vitrification) without permeable cryoprotectants is potentially significant for this industry, but the development of "aseptic" methods, in which the spermatozoa suspension is enclosed in capillaries or straws to prevent direct contact of sperm with liquid nitrogen, will need to be considered. Filtration or ultraviolet treatment of liquid nitrogen cannot guarantee the absence of contamination of biological material by viruses. For example, Tedder et al. (1995) reported the contamination of blood probes by hepatitis virus during the storage of probes in liquid nitrogen. Different types of viruses, such as hepatitis virus, papova virus, vesicular stomatitis virus and herpes virus, which are simple and very cryostable structures, may increase their virulence after direct plunging and storage in liquid nitrogen (Hawkins et al., 1996; Charles and Sire, 1971; Schaffer et al., 1976; Jones and Darville, 1989).

## 6. General conclusion

Data presented in this review shown that the technique of cryopreservation by direct plunging into liquid nitrogen (vitrification) in absence of permeable cryoprotectants has a great perspective. This technique allows significantly protect the important physiological parameters of mammalian and fish spermatozoa against cryo-injuries.



## 7. References

- Aitken RJ and Clarkson JS. Cellular basis of defective sperm function and its association with the genesis of reactive oxygen species by human spermatozoa. *J Reprod Fertil* 1987;81:459-469.
- Aitken RJ, Baker MA. Oxidative stress, sperm survival and fertility control. *Mol Cell Endocrinol* 2006;250:66-69.
- Anchordoguy T, Rudolph A, Carpenter J, Crowe J. Mode of interaction of cryoprotectants with membrane phospholipids during freezing. *Cryobiology* 1987;24:324-331.
- Andrews FC. Colligative properties of simple solutions. *Science* 1976;194:567-571.
- Bailey JL, Bhur MM. Cryopreservation alters the Ca<sup>2+</sup> flux of bovine spermatozoa. *Can J Anim Sci* 1994;74:45-51.
- Billard R. Ultrastructure of trout spermatozoa: Changes after dilution and deep-freezing. *Cell Tissue Res* 1983; 228:205-218.
- Barbas JP, Mascarenhas RD. Cryopreservation of domestic animal sperm cells. *Cell Tissue Bank* 2009;10:49-62.
- Bielanski A, Bergeron H, Lau PCK, Devenish J. Microbial contamination of embryos and semen during long term banking in liquid nitrogen. *Cryobiology* 2003;46:146-152.
- Blaxter J H S. Sperm storage and cross-ertilization of spring and autumn spawning herring. *Nature* 1953;172:1 189-1 190.
- Cabrera E, Ane L, Herraez M. Effect of external cryoprotectants as membrane stabilizers on cryopreserved rainbow trout sperm. *Theriogenology* 2001;56:623-635.
- Cervera R, Garcia-Ximeñez F. Vitrification of zona-free rabbit expanded or hatching blastocysts: a possible model for human blastocysts. *Hum Reprod* 2003;18:2151-2156.
- Charles GN, Sire DJ. Transmission of papova virus by cryotherapy applicator. *J Am Med Assoc* 1971;218 :1435.
- Chen S L, Ji XS, Yu GC, Tian YS, Sha ZX. Cryopreservation of sperm from turbot (*Scophthalmus maximus*, and application to large-scale fertilization. *Aquaculture* 2004; 236: 547-556.
- Chen S, Lien Y, Cheng Y, Chen H, Ho H, Yang Y. Vitrification of mouse oocytes using closed pulled straws (CPS) achieves a high survival and preserves good patterns of meiotic spindles, compared with conventional straws, open pulled straws (OPS) and grids. *Hum Reprod* 2001;16:2350-2356.
- Chohan KR, Griffin JT, Carrell DT. Evaluation of chromatin integrity in human sperm using acridine orange staining with different fixatives and after cryopreservation. *Andrologia* 2004;36:321-326.
- Conget P, Fernfindez M, Herrera G, Minguell JJ. Cryopreservation of rainbow trout (*Oncorhynchus mykiss*) spermatozoa using programmable freezing. *Aquaculture* 1996;143:319-329.
- Cormier N, Bailey JL. A differential mechanism is involved during heparin- and cryopreservation-induced capacitation of bovine spermatozoa. *Biol Reprod.* 2003; 69:177-185.
- Cosson J, Groison A-L, Suquet M, Fauvel C, Dreanno C, Billard R. Marine fish spermatozoa: racing ephemeral swimmers. *Reproduction* 2008;136 277-294

- Critser JK, Huse-Benda AR, Aaker D, Arneson BW, Ball GD. Cryopreservation of human spermatozoa. III. The effect of cryoprotectants on motility. *Fertil Steril* 1988;50:314-320.
- de Lamirande E, Leclerc P, Gagnon C. Capacitation as a regulatory event that primes spermatozoa for the acrosome reaction and fertilization. *Mol Hum Reprod* 1997;3:175-194.
- Deppe M, Ortloff C, Salinas G, Bravo D, Sánchez R. Efecto de la temperatura de incubación y adición de glicerol sobre la preservación del acrosoma en espermatozoides humanos. *Rev Invest Clin* 2004;56:477-482.
- Didion BA, Dobrinsky JR, Giles JR, Graves CN. Staining procedure to detect viability and the true acrosome reaction in spermatozoa of various species. *Gamete Res* 1989;22:51-57.
- Dreanno C, Suquet M, Quemener L, Cosson J, Fierville F, Normant Y, Billard R. Cryopreservation of turbot (*Scophthalmus Maximus*) spermatozoa. *Theriogenology* 1997; 48: 589-603.
- Drokin S, Stein H, Bartscherer H. Effect of cryopreservation on the fine structure of spermatozoa of rainbow trout (*Oncorhynchus mykiss*) and brown trout (*Salmo trutta F. fario*). *Cryobiology* 1998;37:263-270.
- Ellis S. Risk and factors salmon chilean. Assessing infectious disease emergence potential in the U.S. *Aquacult Industr* 2007;1-111. [www.scribd.com/doc/1446078/USDA-aquaculture23](http://www.scribd.com/doc/1446078/USDA-aquaculture23).
- Fabbrocini A.S, Lavadera L, Rispoli S, Sansone G. Cryopreservation of Seabream (*Sparus aurata*) Spermatozoa. *Cryobiology* 2000;40: 46-53.
- Fraga CG, Motchnik PA, Shigenaga MK, Helbock HJ, Jacob RA, Ames BN. Ascorbic acid protects against endogenous oxidative DNA damage in human sperm. *Proc Nat Acad Sci USA*. 1991;88:11003-11006.
- Franks F. Biological freezing and cryofixation. *J Microsc* 1977;111:3-16.
- Fortt Z, Buschmann AR. Residuos de tetraciclina y quinolonas en peces silvestres en una zona costera donde se desarrolla la acuicultura del salmón en Chile. *Rev Chil Infect* 2007;24:8-12.
- Gao D, Mazur P & Critser J 1997 Fundamental cryobiology of mammalian spermatozoa. In *Reproductive Tissue Banking*, 4 edn, pp 263-328. Eds AM Karow & JK Critser. London: Academic Press
- Gardner DK. Development of serum-free media for the culture and transfer of human blastocysts. *Hum Reprod* 1998;13:218-225.
- Gilmore JA, Liu J, Gao DY, Critser JK. Determination of optimal cryoprotectants and procedures for their addition and removal from human spermatozoa. *Hum Reprod* 1997;12:112-118.
- Glander HJ, Schaller J. Hidden effects of cryopreservation on quality of human spermatozoa. *Cell Tissue Bank* 2000;1:133-42.
- Gorczyca W, Traganos F, Jesionowska H, Darzynkiewicz Z. Presence of DNA strand breaks and increased sensitivity of DNA in situ to denaturation in abnormal human sperm cells; analogy to apoptosis of somatic cells. *Exp Cell Res* 1993;207:202-205.
- Green CE, Watson PF. Comparison of the capacitation-like state of cooled boar spermatozoa with true capacitation, *Reproduction* 2001;122: 889-898.

- Hammadeh ME, Askari AS, Georg T, Rosenbaum P, Schmidt W. Effect of freeze-thawing procedure on chromatin stability, morphological alteration and membrane integrity of human spermatozoa in fertile and subfertile men. *Int J Androl* 1999;22:155-162.
- Hawkins AE, Zuckerman MA, Briggs M, Gilson RJ, Goldstone AH, Brink NS, Tedder RS. Hepatitis B nucleotide sequence analysis: linking an outbreak of acute hepatitis B to contamination of a cryopreservation tank. *J Virol Methods* 1996;60:81-88.
- Henkel R, Ichikawa T, Sánchez R, Miska W, Ohmori H, Schill WB. Differentiation of ejaculates showing reactive oxygen species production by spermatozoa or leukocytes. *Andrologia* 1997;29:295-301.
- Henkel RR, Schill WB. Sperm preparation for ART. *Reprod Biol Endocrinol* 2003;1:108.
- Henkel R, Kierspel E, Stalf T, Mehnert C, Menkveld R, Tinneberg HR, Schill WB, Kruger TF. Effect of reactive oxygen species produced by spermatozoa and leucocytes on sperm functions in non-leucocytospermic patients. *Fertil Steril* 2005;83:635-642.
- Henkel R, Bastiaan HS, Schüller S, Hoppe I, Starker W, Menkveld R. Leucocytes and intrinsic ROS production may be factors compromising sperm chromatin condensation status. *Andrologia* 2010;42:69-75.
- Hoagland H, Pincus G. Revival of mammalian sperm after immersion in liquid nitrogen. *J Gen Physiol* 1942;25:337-344.
- Holt W, North RD. Cryopreservation, actin localization and thermotropic phase transitions in ram spermatozoa. *J Reprod Fertil* 1991;91:451-461.
- Holt WV. Fundamental aspects of sperm cryobiology: the importance of species and individual differences. *Theriogenology* 2000;53:47-58.
- Isachenko E, Isachenko V, Katkov II, Dessole S, Nawroth F. Vitrification of mammalian spermatozoa in the absence of cryoprotectants: from past practical difficulties to present success. *Reprod Biomed Online* 2003;6:191-200.
- Isachenko, E., Isachenko, V., Katkov, I.I., Rahimi, G., Schondorf, T., Mallmann, P., Dessole, S., Nawroth, F. (2004a). DNA integrity and motility of human spermatozoa after standard slow freezing versus cryoprotectant-free vitrification. *Hum. Reprod.* 19, 932-939.
- Isachenko, V., Isachenko, E., Katkov, I.I., Montag, M., Dessole, S., Nawroth, F., van der Ven, H. (2004b). Cryoprotectant-free cryopreservation of human spermatozoa by vitrification and freezing in vapor: effect on motility, DNA integrity, and fertilization ability. *Biol. Reprod.* 71, 1167-1173.
- Isachenko V, Isachenko E, Montag M, Zaeva V, Krivokharchenko A, Nawroth F, Dessole S, Katkov I, Van der Ven H. Clean technique for cryoprotectant - free vitrification of human spermatozoa. *Reprod Biomed Online* 2005a;10:350-354.
- Isachenko V, Montag M, Isachenko E, van der Ven H. Vitrification of mouse pronuclear embryos after polar body biopsy without direct contact with liquid nitrogen. *Fertil Steril* 2005b; 84:1011-1016.
- Isachenko, V., Katkov, I.I., Yakovenko, S., Lulat, A.G., Ulug, M., Arvas, A., Isachenko, E. (2007). Vitrification of human laser treated blastocysts within cut standard straws (CSS): novel aseptic packaging and reduced concentrations of cryoprotectants. *Cryobiology* 54, 305-309.
- Isachenko E, Isachenko V, Weiss JM, Kreienberg R, Katkov II, Schulz M, Lulat AG, Risopatron MJ, Sanchez R. Acrosomal status and mitochondrial activity of human spermatozoa vitrified with sucrose. *Reproduction* 2008;136:167-173.

- Isachenko E, Isachenko V, Sánchez R, Katkov II, Kreienberg R. Cryopreservation of spermatozoa: old routine and new perspective. In: Donnez J, Kim SS, eds. Principles and Practice of Fertility Preservation. Cambridge, UK: Cambridge University Press, 2011a:177-198.
- Isachenko V, Isachenko E, Petrunkina A.M., Sánchez R. Human spermatozoa vitrified in the absence of permeable cryoprotectants: birth of two healthy babies. *Reprod Fertil Dev.* 2011b, 24:323-326.
- V. Isachenko, R. Maettner, A. M. Petrunkina, K. Sterzik, P. Mallmann, G. Rahimi, R. Sánchez, J. Risopatrón, I. Damjanoski, E. Isachenko. Vitrification of Human ICSI/IVF Spermatozoa Without Cryoprotectants: New Capillary Technology. *J Androl.*, 2011c. In press
- Isachenko V, Maettner R, Petrunkina AM, Sterzik K, Mallmann P, Rahimi G, Sánchez R, Risopatrón J, Hancke K, Damjanoski I, Kreienberg R, Isachenko E. Cryoprotectant-free Vitrification of Human Spermatozoa in Large (to 0.5 mL) Volume: Novel Technology. *Clin Lab.* 2011d, 57:643-650.
- Jahnel F. Resistance of human spermatozoa to deep cold, *Klinische Wochenschrift* 1938;17:1273-1274.
- Jones SK, Darville JM. Transmission of virus-particles by cryotherapy and multi-use caustic pencils: a problem to a dermatologist? *Br J Dermatol* 1989;121:481-486.
- Karlsson JOM, Cravalho EG. A model of diffusion-limited ice growth inside biological cells during freezing. *J Appl Phys* 1994;75:4442-55.
- Katkov II, V Isachenko, E Isachenko, M S. Kim, A G-M.I. Lulat, A M. Mackay, F Levine. Low- and high-temperature vitrification as a new approach to biostabilization of reproductive and progenitor cells. *Int J Refrigeration* 2006;29:346-357.
- Kay VJ, Coutts JR, Robertson L. Effects of pentoxifylline and progesterone on human sperm capacitation and acrosome reaction. *Hum Reprod* 1994;9:2318-2323.
- Koshimoto C, Gamliel E, Mazur P. Effect of osmolality and oxygen tension on the survival of mouse sperm frozen to various temperatures in various concentrations of glycerol and raffinose. *Cryobiology* 2000;41:204-31.
- Kumar R, Venkatesh S, Kumar M, Tanwar M, Shasmsi MB, Kumar R, Gupta NP, Sharma RK, Talwar P, Dada R. Oxidative stress and sperm mitochondrial DNA mutation in idiopathic oligoasthenozoospermic men. *Indian J Biochem Biophys.* 2009;46:172-177.
- Koshimoto CH, Mazur P. Effects of cooling and warming rate to and from -70°C, and effect of further cooling from -70 to -196°C on the motility of mouse spermatozoa. *Biol Reprod* 2002;66:1477-1484.
- Kuleshova LL, MacFarlane DR, Trounson AO, Shaw JM. Sugars exert a major influence on the vitrification properties of ethylene glycol-based solutions and have a low toxicity to embryos and oocytes. *Cryobiology* 1999;38:119- 130.
- Lahnsteiner F, Berger B, Horvath A, Urbanyi B, Weismann T. Cryopresevation of spermatozoa in cyprinid fishes. *Theriogenology* 2000;54:1 477-1 496.
- Lahnsteiner F, Weismann T, Patzner RA. Fine structural changes in spermatozoa of the grayling, *Thymallus thymallus* (Pisces: Teleostei), during routine cryopreservation. *Aquaculture* 1992;103: 73-84.

- Lahnsteiner F, Berger B, Wiesmann T, Patzner R. Changes in morphology, physiology, metabolism, and fertilization capacity of rainbow trout semen following cryopreservation. *Prog Fish Cult* 1996;58:149-159.
- Lahnsteiner F. Characterization of seminal plasma proteins stabilizing the sperm viability in rainbow trout (*Oncorhynchus mykiss*). *Anim Reprod Sci* 2007;97:151-164.
- Larson JM, McKinney KA, Mixon BA, Burry KA, Wolf DP. An intrauterine insemination-ready cryopreservation method compared with sperm recovery after conventional freezing and post-thaw processing. *Fertil Steril* 1997;68:143-8.
- Levin RL. A generalized method for the minimization of cellular osmotic stresses and strains during the introduction and removal of permeable cryoprotectants. *J Biomech Eng* 1982;104:81-86.
- Lozina-Lozinski LK. Action of cooling on cells and the body as a multifactorial process. *Tsitologiya* 1982;24:371-390.
- Luyet BJ, Hoddap A. Revival of frog's spermatozoa vitrified in liquid air. *Proc Meet Soc Exp Biol* 1938;39:433-434.
- Maisse G. Cryopreservation of fish semen: a review. In: *Proceedings of Refrigeration and Aquaculture, Bordeaux, France, 1996 March*, pp. 443-466.
- Mazur P. Kinetics of water loss from cells at subzero temperatures and the likelihood of intracellular freezing. *J Gen Physiol* 1963;47:374-369.
- Maxwell WMC, Welch GR, Johnson LA. Viability and membrane integrity of spermatozoa after dilution and flow cytometric sorting in the presence or absence of seminal plasma. *Reprod Fertil Dev* 1997;8:1165-1178.
- McLaughlin EA, Ford WC, Hul MG. A comparison of the freezing of human semen in the uncirculated vapour above liquid nitrogen and in a commercial semi-programmable freezer. *Hum Reprod* 1990;5:724-8.
- Merino O, Risopatrón J, Sánchez R, Isachenko E, Figueroa E, Valdebenito I, Isachenko V. Fish (*Oncorhynchus mykiss*) spermatozoa cryoprotectant-free vitrification: Stability of mitochondrion as criterion of effectiveness. *Animal Reproduction Science* 2011;124 :125-131.
- Merino O, Sánchez R, Risopatrón J, Isachenko E, Katkov II, Figueroa E, Valdebenito I, Mallmann P, Isachenko V. Cryoprotectant-free vitrification of fish (*Oncorhynchus mykiss*) spermatozoa: first report. *Andrologia* 2011;1-6.
- Meseguer M, Garrido N, Martinez-Conejero JA, Simon C, Pellicer A, Remohi J. Role of cholesterol, calcium, and mitochondrial activity in the susceptibility for cryodamage after a cycle of freezing and thawing. *Fertil Steril* 2004;82:514-515.
- Moreno D, Fuentes JL, Sánchez A, Baluja L, Prieto E. Conversio'n y reversio'n ge'nica en *saccharomyces cerevisiae*. Un modelo para el estudio del dan'o producido por radiacio´n gamma. *Rev Cubana Invest Biomed* 2004;23:80-86.
- Muller K, Muller P, Pincemy G, Kurz A, Labbe C. Characterization of sperm plasma membrane properties after cholesterol modification: consequences for cryopreservation of rainbow trout spermatozoa. *Biol Reprod* 2008;78:390-399.
- Nakagata N, Takeshima T. High fertilizing ability of mouse spermatozoa diluted slowly after cryopreservation. *Theriogenology* 1992;37:1263-1291.
- Nakagata N, Takeshima T. Cryopreservation of mouse spermatozoa from inbred and F 1 hybrid strains. *Jikken Dobutsu* 1993;42:317-320.

- Nawroth F, Isachenko V, Dessole S, Rahimi G, Farina M, Vargiu N, Mallmann P, Dattena M, Capobianco G, Peters D, Orth I, Isachenko E. Vitrification of human spermatozoa without cryoprotectants, *Cryo Lett* 23;2002:93-102.
- Ngamwuttiwong T, Kunathikom S. Evaluation of cryoinjury of sperm chromatin according to liquid nitrogen vapour method (I). *J Med Assoc Thai* 2007;90:224-228.
- Ogier de Baulny B, Labb C, Maise G. Membrane integrity, mitochondrial activity, ATP content, and motility of the European catfish (*Silurus glanis*) testicular spermatozoa after freezing with different Cryoprotectants. *Cryobiology* 1999;39:177-184.
- Paasch U, Sharma RK, Gupta AK, Grunewald S, Mascha EJ, Thomas AJ Jr, Glander HJ, Agarwal A. Cryopreservation and thawing is associated with varying extent of activation of apoptotic machinery in subsets of ejaculated human spermatozoa. *Biol Reprod* 2004;71:1828-1837.
- Perez LJ, Valcarcel A, Delasheras MA, Moses D, Baldassarre H. Evidence that frozen/thawed ram spermatozoa show accelerated capacitation in vitro as assessed by chlortetracycline assay. *Theriogenology* 1996;46:131-140.
- Pérez-Sánchez F, Cooper TG, Yeung CH, Nieschlag E. Improvement in quality of cryopreserved human spermatozoa by swim-up before freezing. *Int J Androl* 1994;17:115-120.
- Parkes AS. Preservation of human spermatozoa at low temperatures, *Br Med J* 1945;2:212-213.
- Petrunkina AM, Volker G, Weitze KF, Beyerbach M, Töpfen-Petersen E, Waberski D. Detection of cooling-induced membrane changes in the response of boar sperm to capacitating conditions. *Theriogenology* 2005;63:2278-2299.
- Petrunkina AM. Fundamental aspects of gamete cryobiology. *J Reproduktionsmed Endokrinol* 2007;4:78-91.
- Quinn P, Warnes GM, Kerin JF, Kirby C. Culture factors affecting the success rate of in vitro fertilization and embryo transfer. *Ann NY Acad Sci*. 1985;442:195-204.
- Rall WF, Fahy GM. Ice-free cryopreservation of mouse embryos at  $-196^{\circ}\text{C}$  by vitrification. *Nature* 1985;313:573-575.
- Reed ML, Lane M, Gardner DK, Jensen NL, Thompson J. Vitrification of human blastocysts using the cryoloop method: successful clinical application and birth of offspring. *J Assist Reprod Genet* 2002; 19:304-306.
- Risopatrón J, Catalan S, Miska W, Schill WB, Sánchez R. Effect of albumin and polyvinyl alcohol on the vitality, motility and acrosomal integrity of canine spermatozoa incubated in vitro. *Reprod Domest Anim* 2002;37:347-351.
- Robertson L, Watson PF. Calcium transport in diluted or cooled ram semen. *J Reprod Fertil* 1986;77:117-185.
- Robertson L, Watson PF, Plunner JM. Prior incubation reduces calcium uptake and membrane disruption in boar spermatozoa subjected to cold shock. *Cryo Lett* 1988; 19:286-293.
- Roca J, Rodríguez M, Gil M, Carvajal G, García E, Cuello C, Vásquez J, Emilio A. Survival and in vitro fertility of boar spermatozoa frozen in the presence of superoxide dismutase and/or catalase. *J Androl* 2005;26:15-24.
- Rodgers W, Glaser M. Distributions of proteins and lipids in the erythrocyte membrane. *Biochemistry* 1993;32:12591-21298.

- Samper JC. Reproductive anatomy and physiology of the breeding stallion. In: Current Therapy in Large Animal Theriogenology. Younquist RS (ed). WB Saunders, Pennsylvania, 1997; pp. 3–12.
- Sánchez R, Schill WB. Influence of incubation time/ temperature on acrosome reaction/sperm penetration assay. Arch Androl 1991;27:35–42.
- Sánchez R, Isachenko V, Petrunkina AM, Risopatrón J, Schulz M, Isachenko E. Live Birth after Intrauterine Insemination with Spermatozoa from an Oligo-Astheno-Zoospermic Patient Vitrified Without Permeable Cryoprotectants. J Androl 2011a, [Epub ahead of print]
- Sánchez R, Risopatrón J, Schulz M, Villegas J, Isachenko V, Kreinberg R, Isachenko E. Canine sperm vitrification with sucrose: effect on sperm function. Andrologia 2011b;43:233–41.
- Santiani A, Risopatrón J, Sepúlveda N, Sánchez R. Efecto de la lisofosfatidilcolina en la reacción del acrosoma de espermatozoides caninos. Rev Cient FCV-LUZ 2004;14:311–316.
- Sawetawan C, Bruns ES, Prins GS. Improvement of post-thaw sperm motility in poor quality human semen. Fertil Steril 1993;60:706–10.
- Schaffner CS. Longevity of fowl spermatozoa in frozen condition, Science 1942;96:337.
- Schuffner A, Morshedi M, Oehninger S. Cryopreservation of fractionated, highly motile human spermatozoa: effect on membrane phosphatidylserine externalization and lipid peroxidation. Hum Reprod 2001;16:2148–53.
- Silva ME, Berland M. Vitrificación de blastocitos bovinos producidos in vitro con el método Open Pulled Straw (OPS): primer reporte. Arch Med Vet 2004;36:79–85.
- Smiley ST, Reers M, Mottola-Hartshorn C, Lin M, Chen A, Smith TW, Steele GD Jr, Chen LB. Intracellular heterogeneity in mitochondrial membrane potentials revealed by a J-aggregate-forming lipophilic cation JC-1. Proc Natl Acad Sci USA 1991;88:3671–3675.
- Sommer M. Acuicultura Insostenible en Chile (unsustainable aquaculture in Chile). Rev Electr Vet 2009;10:1–23, [www.veterinaria.org/revistas/redvet/n030309.html](http://www.veterinaria.org/revistas/redvet/n030309.html).
- Stanic P, Tandara M, Sonicki Z, Simunic V, Radakovic B, Suchanek E. Comparison of protective media and freezing techniques for cryopreservation of human semen. Eur J Obstet Gyn RB 2000;91:65–70.
- Steer CV, Mills CL, Tan SL, Campbell S, Edwards RG. The cumulative embryo score: a predictive embryo scoring technique to select the optimal number of embryos to transfer in an in-vitro fertilization and embryo transfer programme. Hum Reprod 1992;7:117–119.
- Trus-Cott B, Idler D, Hoyle R, Freeman H. Sub-zero preservation of Atlantic salmon sperm. J Fish Res Board Can 1968;25:363–372.
- Tsutsui T, Tezuka T, Mikasa Y, Sugisawa H, Kirihara N, Hori T, Kawakami E. Artificial insemination with canine semen stored at a low temperature. J Vet Med Sci 2003;65:307–312.
- Tuset VM, Dietrich GJ, Wojtczak M, Słowińska M, de Monserrat J, Ciereszko A. Relationships between morphology, motility and fertilization capacity in rainbow trout (*Oncorhynchus mykiss*) spermatozoa. J Appl Ichthyol 2008;24:393–397.

- Twigg JP, Irving DS, Aitken RJ. Oxidative damage to DNA in human spermatozoa does not preclude pronucleus formation at intracytoplasmic sperm injection. *Hum Reprod* 1998; 13:1864–1871.
- Vadnais ML, Roberts KP. Seminal plasma proteins inhibit in vitro- and cooling-induced capacitation in boar spermatozoa. *Reprod Fertil Dev.* 2010;22:893-900.
- Villlegas J, Schulz M, Vallejos V, Henkel R, Miska W, Sánchez R. Indirect immunofluorescence using monoclonal antibodies for the detection of leukocytospermia: comparison with peroxidase staining. *Andrologia* 2002;34: 69–73.
- Wakayama T, Whittingham DG, Yanagimachi R. Production of normal offspring from mouse oocytes injected with spermatozoa cryopreserved with or without cryoprotection. *J Reprod Fertil* 1998;112:11-7.
- Ward MA, Kaneko T, Kusakabe H, Biggers JD, Whittingham DG, Yanagimachi R. Long-term preservation of mouse spermatozoa after freeze-drying and freezing without cryoprotection. *Biol Reprod* 2003; 69:2100-2108.
- Watson P, Plummer JM. The responses of boar sperm membranes to cold shock and cooling. In: *Deep Freezing of Boar Semen*. Johnson LA, Larsson K (eds). Swedish University of Agricultural Sciences, Uppsala, Sweden, 1985; pp 113–127.
- Wheeler PA, Thorgaard GH. Cryopreservation of rainbow trout semen in large straws. *Aquaculture* 1991;93:95– 100.
- World Health Organization. *Laboratory Manual for the Examination of Human Semen-Cervical Mucus Interaction*, 4<sup>th</sup> ed. Cambridge University Press, New York, 1999.
- Yildiz C, Ottaviani P, Law N, Ayearst R, Liu L, McKerlie C. Effects of cryopreservation on sperm quality, nuclear DNA integrity, in vitro fertilization, and in vitro embryo development in the mouse. *Reproduction* 2007;133:585– 595.
- Yin HZ, Seibel MM. Human sperm cryobanking. Use of modified liquid nitrogen vapor. *J Reprod Med* 1999;44:87-90.
- Zamzami N, Marchetti P, Castedo M, Zanin C, Vayssiere JL, Petit PX, Kroemer G. Reduction in mitochondrial potential constitutes an early irreversible step of programmed lymphocyte death in vivo. *J Exp Med* 1995;181:1661– 1672.
- Zhang, Y. Z., S. C. Zhang, X. Z. Liu, Y. Y. Xu, C. L. Wang, M. S. Sawant, J. Li and S. L. Chen, 2003. Cryopreservation of flounder (*Parabchthys olivaceus*) sperm with a practical methodology. *Theriogenology* 60: 989-996.



# Cryopreservation of Human Spermatozoa by Vitrification vs. Slow Freezing: Canadian Experience

S.I. Moskovtsev<sup>1,2</sup>, A.G-M. Lulat<sup>1</sup> and C.L. Librach<sup>1,2,3</sup>

<sup>1</sup>CReATe Fertility Centre

<sup>2</sup>Department of Obstetrics & Gynaecology, University of Toronto

<sup>3</sup>Division of Reproductive Endocrinology and Infertility,

Department of Obstetrics & Gynaecology, Sunnybrook Health Sciences Centre and Women's College Hospital, Toronto, Ontario Canada

## 1. Introduction

Many advances in reproductive medicine in the past five decades have made cryopreservation of human spermatozoa an invaluable tool for the clinical management of infertility and sperm banking. The advent of in vitro fertilization (IVF) and intracytoplasmic sperm injection (ICSI) with microsurgical sperm handling techniques along with advances in female gamete acquisition have resulted in an increased demand for the cryopreservation of semen and tissue samples, often containing a very limited number of spermatozoa. Sperm cryopreservation also makes it possible for cancer patients to preserve their fertility prior to gonadotoxic chemotherapy or radiation. Applications of sperm banking are not limited to cancer patients but extend to patients undergoing certain types of pelvic or testicular surgeries; those who suffer from degenerative illnesses such as diabetes or multiple sclerosis; spinal cord disease or injury; and persons in occupations where a significant risk of gonadotoxicity prevails. Sperm cryopreservation is also available to men undergoing surgical sterilization such as vasectomy, in the event that children may be desired in the future. Another use for semen cryopreservation is to allow donor semen samples to be quarantined while appropriate screening is performed to prevent the transmission of infectious pathogens during therapeutic donor insemination (TDI).

Although major improvements have been made in sperm cryopreservation, there are many unresolved technical issues. Since freezing protocols differ between types of cells, the ideal conditions for human sperm freezing and thawing need to be perfected. To add more complexity, samples with abnormal semen parameters, such as severe oligospermia or high seminal fluid viscosity, often require unique cryopreservation conditions. For example, the particular cryoprotectants can affect cooling rates. In addition, storage temperature can significantly influence cryopreservation outcome. Liquid nitrogen (LN<sub>2</sub>) can offer long-term survival of spermatozoa due to essentially absent metabolic activity, such as chemical reactions, genetic modification or aging of cells (Mazur, 1984). A conventional slow freezing protocol has been in use for many years and very little has changed in terms of

methodology and reagents. While freezing aims to preserve cells it can also easily destroy them if certain precautionary steps are not taken into consideration. During cryopreservation cells and tissue undergo dramatic transformation in chemical and physical characteristics as the temperature drops from +37 to -196°C. The cells can lose up to 95% of their intracellular water. The concentration of solutes increases considerably, triggering the possibility of osmotic shock. Moreover, potential intracellular ice crystallization and mechanical deformation by extracellular ice may cause significant injury leading to cell death. Furthermore, if cells survive freezing, they might sustain additional damage during the thawing process due to osmotic shock, uncontrollable swelling and ice re-crystallization (Woods, et al., 2004).

Recently scientists have begun to re-investigate the utility of ultra rapid freezing in the search for alternative methods of sperm cryopreservation. Slow freezing of sperm utilizes cooling rates of 1-10°C/min, while the rapid freezing, or vitrification, technique allows for cooling rates to reach more than 40-1000°C/min in order to avoid intracellular ice formation. As new techniques are perfected, there is a potential for sperm cryopreservation to greatly improve in the future.

## **2. Cryopreservation of human spermatozoa**

### **2.1 History of human spermatozoa cryopreservation**

Remarkably, the first reference of empirical sperm freezing dates as far back as the late 16th century, but it was only with the discovery in 1937 by Bernstein and Petropavlovski that glycerol can aid spermatozoa in surviving long term freezing, that sperm cryopreservation became practical. Expansion of artificial insemination for the dairy industry led to further important research in the field of cryobiology (E. Isachenko, 2003, as cited in Bernstein & Petropavlovski, Polge et al., 1949). Shortly after these practices were initiated with animals, the first pregnancies were reported in humans after insemination with frozen spermatozoa. The next milestone was the discovery of the possibility to store human spermatozoa in LN<sub>2</sub> at -196°C, resulting in superior recovery rates compared to storage at higher temperatures between -20 and -75°C. After the era of empirical freezing; cryobiology matured to its fundamental stage, focusing on the biophysical and biochemical principals of cryopreservation, further advancing the field (Mazur et al., 1972). A comprehensive review of the historical background of sperm freezing was recently published and is recommended for readers looking for more details (Katkov et al., 2006).

### **2.2 Biological aspects of freezing**

Living cells have an isotonic condition with a melting point of their intracellular water of approximately -0.6°C. When cells are cooled below this standard freezing point, supercooling takes place and remains in a metastable state up to -5°C (Katkov et al., 2006; Mazur et al., 1972). Water crystallization and ice formation begin between -5 and -15°C, beginning with the formation of an ice nucleus (seed crystal) in the extracellular water. This 'nucleation' can be induced at a higher temperature by the planned external facilitation of ice formation, often referred to as "seeding". Prior to that stage, water remains unfrozen inside the cell as the membrane prevents ice crystals from intracellular penetration (Woods et al., 2004). Solutes are excluded from ice formation which results in rising concentrations

of solutes within extracellular water. Due to the permeability of the plasma membrane, this chemical imbalance sets up the diffusion of solutes into the cell, forcing water out of the cell. Cells thus undergo excessive dehydration, losing up to 95% of their intracellular water content. This increases the intracellular concentration of solutes, resulting in denaturation of proteins, pH shifts and potential cell death.

Since velocity of cooling is crucial, inaccurate cooling rates can negatively affect sperm survival, motility, plasma membrane integrity and mitochondrial function (Henry et al., 1993). When cooling is slow enough, there is sufficient time for intracellular water efflux and balanced dehydration. If cooling is too slow, damage may occur due to exposure of cells to high concentrations of intracellular solutes. Extreme cellular dehydration leads to shrinkage of cells below the minimum cell volume necessary to maintain its cytoskeleton, genome-related structures, and ultimately cellular viability (Mazur, 1984). On the other hand, if cooling rates are too fast, external ice can induce intracellular ice formation and potential rupture of the plasma membrane and damage intracellular organelles. In addition, mechanical damage of cells is possible due to of extracellular ice compression and close proximity of frozen cells can result in cellular deformation and membrane damage (Fujikawa & Miura, 1986). In contrast, with ultra rapid cooling, the amount of ice formation is insignificant and the entire cell suspension undergoes vitrification. At this stage water transitions, ice formation slows, molecular diffusion and aging stops, and liquids turn into a glass-like condition (Katkov et al., 2006).

Despite the relative insensitivity of human sperm to freezing, optimal cooling rates are needed to ensure appropriate sperm recovery. Currently, there are two types of slow freezing, either static vapour phase freezing to a certain temperature, or the multistep approach using nonlinear controlled-rate freezers, followed by plunging into LN<sub>2</sub>. Most laboratories and sperm banks adapt simple static vapour phase cooling in order to avoid induction of ice nucleation by seeding. For this technique samples are lowered into a vapour phase just above the LN<sub>2</sub> level, allowing them to cool for 15-20 minutes before being plunged into LN<sub>2</sub>. Alternately, controlled rate freezers can be used to cryopreserve human semen. Most of these protocols utilize a "no seeding" option where samples are cooled from room temperature to -4°C at the rate of 2°C/min, followed by an increase of the cooling rate to 10°C/min until -100°C is reached, and finally plunging into LN<sub>2</sub> (Morris et al., 1999). In contrast to these slow freezing techniques, single step ultra rapid cooling is used for the vitrification technique.

### **2.3 Cryoprotective agents (CPAs)**

Most cells would not survive cryopreservation without CPAs, which can minimize cryo-injury of cells. CPAs are low molecular weight chemicals that serve to protect spermatozoa from freezing damage or ice crystallization by decreasing the freezing point of materials. There are two categories of CPAs, and they differ in their ability to penetrate the plasma membrane. Firstly, permeating CPAs such as dimethylacetaldehyde; dimethyl sulfoxide, glycerol, glycol, ethylene and methanol, stabilize cell plasma membrane proteins and reduce concentrations of electrolytes (Arakawa et al., 1990). In contrast, nonpermeating CPAs such as albumins, dextrans, egg yolk citrate, hydroxyethyl, polyethylene glycols, polyvinyl pyrrolidone and sucrose, minimize intracellular crystallization by increasing viscosity of the sample. CPAs themselves can be toxic if used at high concentrations and spermatozoa are

vulnerable to osmotic changes induced by these agents (Gao et al., 1993). Despite the use of CPAs, plasma membranes can still be damaged or ruptured due to the initial extensive dehydration followed by cell swelling and osmotic stress. Gradual introduction of CPAs to the cell suspension or stepwise increase in their concentration, with a limited waiting period prior to freezing, is utilized to minimize the potential negative effects of these agents (McGann & Farrant, 1976).

## **2.4 Biological aspects of thawing**

While there are many risk factors associated with freezing of cells, thawing can also dramatically affect survival rates of spermatozoa. When frozen samples are returned to ambient temperature, a reversal of the freezing process takes place. Cells that were frozen by the slow method, are more vulnerable to rapid thawing, due to the fast influx of water into cells causing uncontrollable swelling and osmotic shock (Curry & Watson, 1994). If cells were frozen rapidly, intracellular ice crystals could re-crystallize and form larger crystals during a slow thaw. To minimize toxic effects, CPAs have to be promptly removed from the cell suspension by washing samples in isotonic solution. Therefore, the thawing process and CPAs removal technique utilized must take into account the original method that was used for freezing.

## **2.5 Cryopreservation of spermatozoa for assisted reproductive techniques (ART)**

Sperm cryopreservation is widely used in combination with ART techniques such as intrauterine insemination (IUI), IVF and ICSI. Despite many years of research and the discovery of new CPAs, significant numbers of spermatozoa still do not survive cryopreservation (Morris, 1999). Both freezing and thawing can inflict irreversible injury on a proportion of human spermatozoa, marked by a significant increase in some apoptosis markers (Giraud et al., 2000). Lipid peroxidation can lead to a decrease in sperm velocity, motility, viability, and mitochondrial activity (Mossad et al. 1994; O'Connell et al. 2002). The recovery rates of intact spermatozoa are highly dependant on the pre-freezing sample quality (de Paula et al., 2006). Poor quality semen may be more prone to DNA damage and cell death after cryopreservation than normal semen samples and thus have lower fertilizing capacity (Borges et al., 2007). It has been shown that reactive oxygen species (ROS) production impacts membrane fluidity and the recovery of motile, viable spermatozoa after cryopreservation. As well, semen samples containing leukocytes may have higher DNA fragmentation. In addition, the cryopreservation process can diminish the antioxidant activity of the semen fluid making spermatozoa more susceptible to ROS-induced damage (Lasso et al., 1994). The occurrence of sperm DNA damage may also be associated with the thawing process. A rapid increase in post thaw sperm DNA fragmentation over time has been observed, with the highest rate of fragmentation occurring during the first four hours after thawing (Gosalvez et al., 2009).

Normozoospermic semen samples appear to be more resistant to damage induced by freezing and thawing compared with oligozoospermic or asthenozoospermic samples. It has been reported that motile spermatozoa can be recovered after five refreezing and thawing rounds in normozoospermic samples, but only after two rounds in cases of oligozoospermia (Verza et al., 2009). Spermatozoa of infertile men were also found to be less resistant to damage during cryopreservation compared with spermatozoa from fertile men (Donnelly et

al., 2001). Optimization of both CPAs concentrations and cryopreservation protocols will maximize survival of spermatozoa and thus improve ART outcome.

## **2.6 Cryopreservation of epididymal and testicular spermatozoa**

Couples with male factor infertility represent 30 to 40% of the infertile population. Azoospermia accounts for 10% of cases of confirmed male infertility, and often requires surgical retrieval of spermatozoa. Since the introduction of ICSI, many cases of severe male infertility can now be successfully treated. Cryopreservation of surgically retrieved spermatozoa is a valuable component in the effective management of male infertility, reducing the necessity of repeat surgeries. Diagnostic sperm retrieval prior to IVF has several benefits including the possibility of freezing spermatozoa for future use, or if none are retrieved, initiation of the IVF stimulation cycle can be postponed or avoided. Testicular spermatozoa have been utilized to achieve pregnancy in couples with severe male factor infertility, with reported pregnancy rates similar to ejaculated spermatozoa, according to a meta-analysis study (Nicopoulos et al., 2004). In the case of obstructive azoospermia, recovery of spermatozoa by aspirations varies from 45 to 97% (Craft et al., 1995; Lania et al., 2006). In cases of non obstructive azoospermia recovery depends on the degree of testicular pathology and varies from 0 to 64% (Schlegel et al., 1997; Hauser et al., 2006). A second or third surgery can increase the chance of complications including hematomas, inflammation, testicular devascularization, fibrosis and permanent testicular damage (Schlegel and Su, 1997). To avoid this, if pregnancy is not achieved during the first ICSI attempt, a repeat of the surgical procedure would not be required if a portion of the surgical specimen has been banked. Cryopreservation of surgically retrieved spermatozoa can also aid the coordination of oocyte retrieval and avoids the pressure of having the urologist available on the day of the ICSI procedure. Usually the number of spermatozoa obtained during a surgical procedure is limited, and in the case of testicular sperm they may not be fully matured. In the future, if no mature spermatozoa are recovered, spermatogonial stem cells or early germs cells could potentially be matured in vitro and used for fertility treatments (Hwang & Lamb, 2010).

There are significant technical challenges for successful cryopreservation of testicular tissue due to its complex structure and intracellular interactions. Different cells of testicular tissue will have dissimilar responses to cryopreservation and require different concentration of CPAs. Freezing larger pieces of tissue is not advisable as it would increase resistance of heat transfer and penetration of CPAs leading to variation in cooling rates within different parts of the tissue. In addition, seminiferous tubules capture liquid and increase chances of ice formation (Woods et al., 2004). To avoid these difficulties, cryopreservation of smaller tissue fragments or mincing tissue prior to freezing has been advocated (Hovatta, 2003).

## **2.7 Cryopreservation of low number or single spermatozoa**

The idea of cryopreservation of low numbers or individual spermatozoa was introduced more than a decade ago (Cohen et al., 1997). While this approach remains very attractive, there are multiple biological and technical issues to overcome. Early attempts to freeze individual spermatozoa were performed by placing them in empty animal or human zona pellucida prefilled with CPAs (Walmsley et al., 1998). Data from these studies suggested lower recovery and fertilization rates with human zona in comparison to hamster, possibly due to the presence of the ZP3 binding protein and induced acrosome reactions when human zona were

used (Cohen et al., 1997). While this method requires special skills, equipment, and is very labour-intensive; live births were reported using both human and hamster zona (Walmsley et al., 1998). Spermatozoa were also injected and frozen within spheres of *Volvox Globator* algae and recovered after thawing using an ICSI needle (Just et al., 2004). While all of these methods appear to be attractive for single spermatozoa cryopreservation, they have a number of limitations. Issues around the use of donor human zona pellucida as well as exposure of human gametes to animal or algae genetic materials present potential risks that restrict the use of such methods for human ART procedures. While in theory zona could be obtained from the female partner of men with severe male infertility, this would be unrealistic in the clinical setting, as it would require IVF egg retrieval and destruction of ooplasm to obtain empty zona pellucidae. An alternative proposal would be to use a non-biological carrier such as non-toxic polysaccharide alginate agarose to cryopreserve small numbers of sperm (Herrler et al., 2006, Isaev et al., 2007). In these studies spermatozoa were mixed with CPAs and added to the alginate before the gelatin stage and then frozen in small bead microspheres. After cryopreservation, they were dissolved in a sodium citrate solution. The residual alginic acid on the sperm membrane can reduce sperm motility with slow freezing (Herrler et al., 2006). Agarose microspheres were also frozen in 0.25 cc straws by vitrification with better recovery rates (Isaev et al., 2007). Another reported method was to divide the sample into several small aliquots of 15–20- $\mu$ l and to freeze in 0.2-mm cryopreservation embryo straws cut into smaller sections, sealed on one end (Desai et al., 2004). Conventional and open-pulled straws containing 1 or 5  $\mu$ l of sperm suspension frozen by vitrification has also been reported (V. Isachenko et al., 2005). However, individual spermatozoa could not be easily sequestered because of possible adherence to the walls of the straws. ICSI pipettes were suggested as a container to freeze individual spermatozoa by either the slow method or vitrification (AbdelHafez et al., 2009; Sohn et al., 2003). Cryopreservation of sperm in microdroplets containing 1 or 40  $\mu$ l of spermatozoa in cryoprotectant placed on a cold surface or directly plunged into liquid nitrogen was also reported (Gil-Salom et al., 2000; Isachenko et al., 2005). Microdroplets covered by mineral oil in a plastic tissue culture dish placed in liquid nitrogen were also used to cryopreserve individual spermatozoa (Quintans et al., 2000; Sereni et al., 2008). A nylon cryoloop first introduced for embryo freezing was successfully used to cryopreserve small volumes of sperm suspension by both slow freezing and vitrification (Nawroth et al., 2002; Schuster et al., 2003; V. Isachenko et al., 2004; Desai et al., 2004). However direct placement of sperm into LN<sub>2</sub> without a container using an 'open system' such as cryoloop or unsealed culture dish increases the risk of cross-contamination and such techniques are discouraged by regulatory agencies such as the FDA and the European Tissue Directive on Sperm.

Overall reported recovery rates of a known number of frozen spermatozoa varied from 59 to 100% with reported survival rates of 8–85% and motility of 0 to 100%. The wide ranges of results depended on patient population, initial quality and number of frozen spermatozoa, as well as the type of cryopreservation device, type of cryoprotectant, and freezing and thawing protocols.

## **2.8 Sperm packaging and relation to the method of cryopreservation**

Storage of frozen samples has to be in suitable freezing containers and at an optimal temperature to ensure long term survival. The packaging containers must meet several criteria. They must: 1) hold freezing temperatures without cracking or leaking, 2) have a large

surface to enable a uniform cooling rate of the sample, 3) have proper heat exchange properties, 4) be easy to label and seal securely and 5) be available in small sterile units. When storage packaging is chosen, the possible risk of microbial or viral contamination must also be considered. The type of packaging also depends on the freezing protocol and sometimes on the quality of the sample. For conventional slow freezing, the two most common types of containers currently used are plastic screw-top vials or straws. Straws can be made of polyethylene terephthalate glycol (PETG) or ionomeric resin (CBS High Security Straws by CryoBioSystem, Paris, France). As described above, a low number or single spermatozoa have been experimentally frozen in empty animal or human zona pellucida, spheres of *Volvox Globator* algae, alginate agarose bead microspheres and ICSI pipettes (AbdelHafez et al., 2009; Herrler et al., 2006; Isaev et al., 2007; Just et al., 2004; Walmsley et al., 1998). For vitrification purposes different types of storing strategies have been suggested. These include: cryoloops, electron microscope copper grids, nylon meshes, open-pulled straws and standard open straws (V. Isachenko et al., 2005).

### **3. Cryopreservation of human spermatozoa by vitrification**

#### **3.1 Background on vitrification of spermatozoa**

Vitrification is an alternative method of freezing based on the rapid cooling of water to a glassy state through extreme elevation of viscosity without intracellular ice crystallization (Fahy, 1986; Katkov et al., 2006). The relationship between the size of different cells, particularly, different spermatozoa species, and the ability of cells to be vitrified are discussed in details in the paper by Katkov (Katkov et al., 2006).

The earliest experiments on vitrification from the 1930s was not successful because critical rates of cooling were unachievable at that time. With the use of LN<sub>2</sub> and the discovery of cryoprotectants, however, it became possible to vitrify many types of cells. The five basic ways to achieve vitrification have been described in details by Katkov et al.: equilibrium freezing-out of the bulk of water with the use of CPAs and storage at ultra low temperature; lyophilization using slow freezing to moderately low (-40 °C) followed by secondary drying at +30°C (mostly used in food and pharmaceutical industries); ice-free vitrification at high rates and high concentration of CPAs; ice-free vitrification at very fast rates without permeable agents ("CPAs-free vitrification"); high temperature' vitrification by air/vacuum drying at temperature above 0°C (Katkov et al., 2006).

However, until only recently, vitrification of spermatozoa was unsuccessful, possibly due to high concentrations of permeable CPAs (30-50% compared to 5-7% with slow freezing) and low tolerance of spermatozoa to permeable agents. Even brief exposure to a high concentration of CPAs can lead to toxic and osmotic shock and would be lethal for spermatozoa. One possible strategy to lower the concentration of CPAs could be to increase the speed of cooling and warming temperatures as higher rates of cooling and warming, require lower concentrations of CPAs; these conditions can help eliminate intracellular ice crystallization, and facilitate the formation of a glassy state (Katkov et al., 2006). Another option is to add non-permeable CPAs--such as carbohydrates--to permeable CPAs to minimize osmotic shock by decreasing osmotic pressure and stabilizing the nuclear membrane. Since the intracellular matrix of human spermatozoa contains large amounts of proteins and sugars, they can be successfully frozen in the absence of permeable CPAs using protein- and sugar-rich non-permeable agents (Koshimoto et al., 2000).

Successful vitrification of human spermatozoa was first reported by the Isaschenkos' group (Nawroth et al, 2002; E. Isachenko et al, 2003). The high viscosity of the intracellular milieu due to large amounts of proteins, nucleotides and sugars and low water in human spermatozoa content determines the ability of human sperm to be vitrified at relatively low cooling rates (Katkov et al., 2006). It was noted that human spermatozoon is one of the smallest germ cells among mammals, has almost no residual histones and has very compacted DNA (Holt, 2000), which indirectly confirms this hypothesis (see also Chapter by Katkov et al in this Book).

As we mentioned above, the major breakthrough in successful vitrification of *human* spermatozoa without the use of permeable CPAs was reported only recently by the Isachenko group (Nawroth et al., 2002), who actually re-invented the work of the "pioneers" in the 1930-40s mentioned above. The combination of extremely high rates of cooling/warming and utilization of vitrification media containing proteins and polysaccharides made it feasible to avoid de-vitrification during warming without use of toxic CPAs. The same group compared viability, survival rate and sperm DNA damage between slow freezing and vitrification and found that DNA integrity was independent from the mode of cooling and the presence of cryoprotectants in thawed spermatozoa (V. Isachenko et al., 2004). The acrosome reaction, capacitation and mitochondrial activity of spermatozoa were compared vis-a-vis slow freezing and vitrification (E. Isachenko et al., 2008). The group reported that changes in the mitochondrial membrane potentials relate to the type of vitrification media with the best achieved results when both sugar and albumin were added to the media. To achieve high cooling rates the vitrification specimen volume needs to be kept to a minimum. Specially designed freezing carriers such as cryovolumes and electron microscope copper grids have been suggested for vitrification of human spermatozoa (E. Isachenko et al., 2003; Nawroth et al., 2002). However, placing drops of semen directly into LN<sub>2</sub> raises the issue of the potential risk of microbial or viral cross contamination during freezing and storage (Katkov, 2002). The development of aseptic techniques of vitrification allowing to freeze 5-10 µl of sperm suspension in open-pulled straws (OPS) or 1-2 µl of sample cut standard straw (CSS) placed inside of insemination straw further advanced the methodology of human sperm vitrification (V. Isachenko et al., 2005). The ultra-high freezing rates utilized for vitrification, via direct plunging of specimens into LN<sub>2</sub>, leads to solidification of a solution by an intense increase in viscosity during cooling which avoids water crystallization and damaging ice formation (Katkov et al., 2006).

Most importantly, vitrified spermatozoa were successfully utilized in ICSI treatment with clinical pregnancy resulting in delivery of healthy twins (E. Isachenko et al., 2011). While only a small volume 0.2 to 40 µl of sample suspension was frozen in the past, recently larger amounts of spermatozoa (100 µl) were successfully vitrified using newly developed straw packaging system (SPS) made from cut in half 0.25 ml plastic straw (E. Isachenko et al., 2011). A first live birth was reported following intrauterine insemination of semen vitrified without permeable cryoprotectants from patient with oligoasthenozoospermia making this freezing technique even more attractive in clinical practice (Sanchez et al., 2011).

### **3.2 Vitrification of human spermatozoa: Canadian experience**

Encouraged by the findings of the German group, we have also looked at possibilities to utilize vitrification in our laboratory. We have compared sperm motility, kinetics and DNA



damage between semen samples cryopreserved by standard vapour freezing verses vitrification protocols (Moskovtsev et al., 2011). Semen samples from 11 patients presenting for infertility were washed by density gradient centrifugation and evaluated by Computer-Aided Sperm Analysis (CASA). Subsequently kinematic parameters were assessed as previously described: sperm motility, average path velocity (VAP) curvilinear velocity (VCL), straight-line velocity (VSL), linearity (LIN), amplitude of lateral head displacement (ALH) (Moskovtsev et al., 2009). However, kinematic parameters are averages of values obtained from analyzing the entire motile fraction of cells in a sample and include absolute (actual) parameters (VAP, VCL, VSL, ALH) and relative (derived) such as LIN. When cryopreserved samples are evaluated after thawing, the CASA-paradox can take place, when despite of deterioration of semen samples after cryopreservation “pseudo-enhancement” of kinematics characteristics is observed (Katkov & Lulat, 2000). Modified Kinematic Parameters (MKP) were calculated as previously described: Kinematic Parameters (KP) x Motility/ 100% To account for this phenomenon, modifications of actual CASA-parameters are recommended and are incorporated into our data (Table 1). (Katkov& Lulat, 2000).

Parameters	Prior to freezing	Post vitrif.	Post vitrif. MKP	Post slow freezing	Post slow MKP	P (vitrif. vs. slow freezing)
Motility (%)	68.0 ± 10.79	25.4 ± 13.6		14.6 ± 10.2		< 0.05
Rapid motility (% of motile)	50.64 ± 4.52	19.45 ± 12.98	4.9 ± 3.3	10.45 ± 8.49	1.5 ± 1.2	< 0.05*
VAP (microns/sec)	60.73 ± 8.93	43.09 ± 14.24	10.9 ± 3.6	38.00 ± 8.57	5.5 ± 1.2	< 0.05
VSL (microns/sec)	47.73 ± 9.39	35.45 ± 13.98	9.0 ± 3.5	31.00 ± 8.27	4.5 ± 1.2	< 0.05
VCL (microns/sec)	96.18 ± 3.68	81.18 ± 21.31	20.6 ± 5.4	68.73 ± 13.01	10.0 ± 1.9	< 0.05
ALH (microns)	4.42 ± 0.79	4.3182 ± 0.80	1.1 ± 0.2	3.67 ± 0.85	0.5 ± 0.1	< 0.05
LIN (ratio of VSL/VCL)	49.91 ± 0.55	42.45 ± 7.43	10.8 ± 1.9	45.91 ± 5.59	6.7 ± 0.8	< 0.05
TUNEL (%)	7.5 ± 5.5	9.6 ± 4.4		9.5 ± 5.1		NS

Note: \* Statistically significant P values, when compared between MKP of samples frozen by vitrification vs. slow freezing.

Table 1. Comparison of CASA and TUNEL results between semen samples frozen by vitrification and slow freezing.

Our results indicate that sperm motility was significantly reduced for both types of frozen-thawed samples ( $P < 0.03$ ) (Table 1). Mean motility of vitrified samples was  $25.4\% \pm 13.6$  (a decrease of 36.4% compared to samples prior to freezing), which was almost two-fold higher compared to motility of samples frozen by standard slow vapour protocol ( $14.6\% \pm 10.2$ , decrease of 47.2% compared to samples prior to freezing), ( $P < 0.05$ ). Sperm kinematics such as VCL, VSL, and LIN were not significantly different between the two types of cryopreservation protocols without taking into account CASA- paradox. However, when MKP were calculated, it was revealed that indeed vitrified samples had superior recovery of sperm kinematic parameters in comparison to slow freezing.

Samples for slow vapour freezing were diluted 3:1 with commercial cryoprotectant medium and frozen by standard protocol in CBS. Aliquots of samples for vitrification were diluted 1:1 with a G-IVF medium (Vitrolife, Göteborg, Sweden) supplemented with 0.25M sucrose and 1% of LSPS (Life Global Protein Supplement, IVF Online, Guelph, ON, Canada). We have used 0.5 ml OPS and loaded 5  $\mu$ l of vitrified sample in each straw by capillary; OPS were inserted into 0.5 CBS straws and sealed (Figure 1).

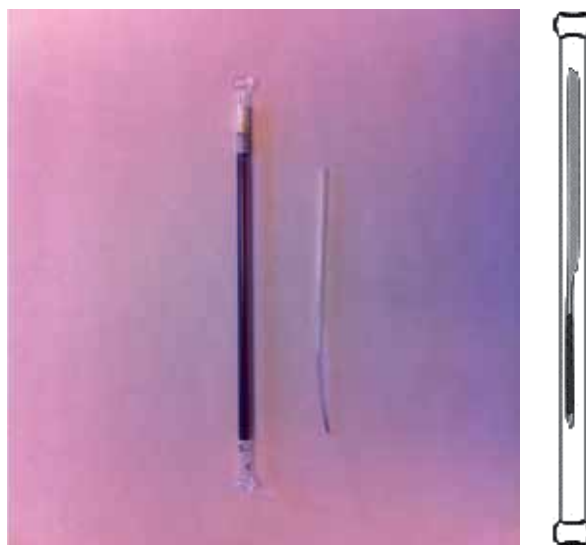
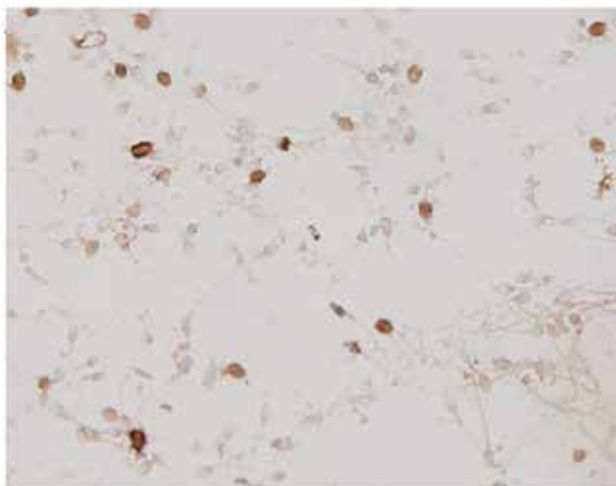

Fig. 1. Comparison of 0.5 ml CBS straw and 0.5 cc OPS straw and schematic of OPS inserted and sealed inside a CBS.

Samples were immediately plunged into LN<sub>2</sub> and stored there for several days. For thawing procedure, OPS were rapidly removed from CBS straws, and plunged into 2 ml of the same medium used for vitrification at 37°C for 10 seconds.

We have evaluated the effect of cryopreservation on sperm DNA damage as the subject remains controversial. |While several reports indicate no negative effect of freezing on sperm DNA integrity (Duty et al., 2002; V. Isachenko et al., 2004). others have reported significant negative effect of sperm cryopreservation and DNA damage and chromatin stability (Hammadeh et al., 1999; Said et al., 2010). Significant increase in percentage of DNA fragmentation was associated with an increase in oxidative stress during cryopreservation

(Thomson et al., 2009). A slide-based technique for the assessment of sperm DNA was performed as previously described (TUNEL: TdT-mediated dUTP nick end labelling) (Moskovtsev et al., 2010) (Figure 2).



**Note:** Brown (TUNEL-positive): damaged DNA; gray-green (TUNEL-negative): undamaged cells.

Fig. 2. Sperm DNA damage assessment by TUNEL assay.

We found statistically significant increase in sperm DNA damage after both methods of sperm freezing ( $P < 0.05$ ). However, the increase in DNA damage was minimal and to a degree probably irrelevant to clinical concerns. No significant differences were observed in sperm DNA damage between slow freezing and vitrification ( $9.6 \pm 4.4$  vs.  $9.5 \pm 5.1$ ).

We can now confirm previous reports that human spermatozoa can be successfully vitrified without the use of potentially toxic cryoprotectants. The vitrification protocol showed significantly better results in preserving motility rates of spermatozoa when compared to slow vapour freezing. No significant differences were observed in post thaw sperm DNA damage in comparison to the standard slow freezing method. While our results are based on the freezing of a small volume of specimens, we are evaluating vitrification of larger volumes of spermatozoa with a proprietary mixture developed in our laboratory in CBS. We have achieved comparable results with both small volume (5  $\mu$ l) and relatively large volume of 200  $\mu$ l semen samples (unpublished data).

## 4. Sperm banking

### 4.1 Referring patients to a sperm bank

Human semen cryobanking can be divided into two broad categories: autologous banking for personal fertility preservation and donor sperm banking. Semen banking is useful in many situations and can be considered a safeguard against unforeseen future circumstances. These may include: prior to chemotherapy or radiation therapy; pre- vasectomy; before certain types of pelvic or testicular surgery; in cases of degenerative illnesses such as diabetes or multiple sclerosis, spinal cord disease or injury; high risk occupations or sports;

and preparation for future fertility treatment. Usually several steps are required prior to initiation of semen storage. Most sperm banks only accept patients referred by their physician, however sometimes self referral is possible. Patients have to be screened by collection of blood, urine and semen samples to ensure that their samples will not contaminate others with infectious diseases when placed into storage. Consent for freezing and storage of semen has to be signed and witnessed. It is important that patients have a clear understanding of the process of banking and that they provide clear instructions on who is responsible for the disposition of the specimens in the event of their demise. Similarly, costs associated with banking and long term storage need to be clearly defined and assigned in case the patient becomes incapacitated. When samples are either used for procreation, transported to another facility, or storage is to be discontinued, the patient or designate must complete specific consent forms allowing the bank to comply with their wishes. In most countries it is assumed or stated by law that the semen belongs to the individual who produced the sample, and it is this individual who must sign all consents, unless the sample was designated for donation (e.g., in the case of anonymous sperm donation). If possible, multiple donations are usually recommended to ensure an adequate sperm reserve for future procreation, depending on the quality of the sample, individual circumstances and reason for sperm banking.

#### **4.2 Methods of sperm collection and retrieval**

In most cases patients are able to produce an ejaculate by masturbation. Patients are given instructions to have minimum of 2 days and a maximum of 5 days of sexual abstinence, and to collect an entire ejaculate into a sterile specimen container. Condoms, creams or lubricants must not be used during collection as they can interfere with sperm motility and vitality due to the spermicidal properties of many products. Some patients would not be able to produce sample at the sperm bank by masturbation due to psychological, medical reasons or religious restrictions. In this case collection of samples by intercourse using a non-spermicidal condom, often referred to as a "semen collection device", is acceptable. Penile vibratory stimulation (PVS) can be helpful in spinal cord injury patients and those who are unable to produce semen by masturbation or intercourse (Brackett et al., 1998). However samples collected after PVS often exhibit relatively low motility (Hovav et al., 2002). PVS can help to produce a semen sample in most patients with spinal cord injuries (Brackett et al., 1998).

In some situations, collection of a retrograde sample is necessary. Retrograde ejaculation is a condition in which some or all of the sperm are not expelled through the urethra during ejaculation, but because of an incompetent bladder neck, the ejaculate refluxes back into the bladder. Reasons for this problem include organic conditions such as diabetes or multiple sclerosis, or pharmacological effects (eg. alpha adrenergic blocker use for hypertension). The general approach is to neutralize the urine pH and normalize the urine osmolarity by giving the patient sodium bicarbonate to alkalinize his urine. The urine sample is subsequently washed and used for insemination, in-vitro fertilization or cryopreservation. In patients with anejaculation, electro-ejaculation might be necessary to obtain semen, but this usually requires anaesthesia and has the associated risk of rectal injury. Additionally, samples produced by electro-ejaculation tend to be of relatively low quality (Denil et al., 1996).

Surgical sperm retrieval should be the last option in patients who can not produce a sample or patients who are diagnosed with azoospermia. Several methods of sperm retrieval are available depending on the etiology of the problem. To retrieve epididymal spermatozoa in cases of obstruction, percutaneous epididymal sperm aspiration (PESA) can be performed without surgical scrotal exploration, it is repeated easily, and does not require an operating microscope or expertise in microsurgery. Microsurgical epididymal sperm aspiration (MESA) is performed under the operating microscope and general anaesthesia. Individual tubules of the epididymis are isolated and aspirated. Testicular sperm aspiration (TESA) is a needle biopsy of the testicle. It is an office procedure performed under local anaesthesia. Testicular sperm extraction (TESE) is the process of making a small incision and removing a small portion of tissue from the testicle under sedation or local anaesthesia. Microdissection (or sometimes referred to as microscopic or microsurgical) testicular sperm extraction (MicroTESE) is a very rigorous search for sperm under high magnification in cases of azoospermia or extremely low sperm production. MicroTESE is usually performed in the operating room under general anaesthesia utilizing an operating microscope. Cryopreservation of surgically retrieved epididymal and testicular spermatozoa is a valuable component in the effective treatment and management of these patients and it reduces the necessity of repeat surgeries when the initial procedure is unsuccessful or if additional children are desired.

#### **4.3 Long term storage**

Proper long term storage is usually achieved by placing specimens in LN<sub>2</sub> freezers, which have been safely used since the 1970s. Some automated systems are available and are capable of LN<sub>2</sub> autofilling, supplied with alarms and data recordings for all activities and are designed to minimize the chances of loss or damage of samples. Despite automation, quality control procedures must be implemented by sperm banks to ensure proper monitoring and safety of samples and staff. The LN<sub>2</sub> itself can be a source of microbial contamination so every available practical step has to be considered to reduce the risk of transmission (Fountain et al., 1997). In general cross-contamination of frozen samples by pathogens are extremely rare, and have not been reported in the setting of sperm banks. It is, however, theoretically possible, as often patients are not fully screened prior to freezing, as in cases of autologous sample cryopreservation or due to time constraints for oncology banking (Clarke, 1999). "Quarantine" tanks are often used to separate samples with pending, unclear laboratory results or unscreened patients. However, contamination is still possible, as released samples that are moved to long term storage could have acquired pathogenic contamination from one of other "pending" samples in the quarantine tank. When samples are cryopreserved for patients with known infections such as HIV or hepatitis B and C carriers, separate tanks for each type of infection are required (Tomlinson & Sakkas, 2000). Cross-contamination can also be avoided by storage of samples in nitrogen vapour. However, in contrast to liquid nitrogen, there are some concerns that vapour has poor heat transfer rates, lower thermal capacity, and significant temperature fluctuation may exist within the vapour (Tomlinson & Saakas, 2000; Wood, 1999). Some older types of vapour storage systems could only guarantee the maintenance of temperature around -100°C and were not acceptable for long term sperm storage. Storage temperatures have to be maintained below -135°C to ensure a glass-like condition of frozen water and for secure long

term storage of semen samples (Clarke, 1999). Newer types of high efficiency LN<sub>2</sub> vapour freezers and others that have a LN<sub>2</sub> "jacket" provide working environments of below -160°C and are more suitable for sperm banks.

#### **4.4 Quality control and quality assurance**

Amongst the many government or professional organizations that require periodic inspection of frozen samples, the standards put forward by Health Canada are the strictest (Health Canada, 2000). Rigorous standards of operation are essential for sperm banks. Sperm banks must have specific requirements for screening, processing and quarantine of samples. Licensing is required in some countries and sperm banks are inspected in accordance with existing standards or regulations. While auditing is absolutely necessary, it might pose the risk of exposure of frozen specimens to room temperature while such inventory is performed. Straws thaw more rapidly than vials and can warm up to -80°C within 8 to 15 seconds at room temperature, dramatically increasing the possibility of damaging samples during inventory or verification of samples' identity (Tyler et al., 1996). Clear labelling systems to easily identify and link samples to a specific donor or patient must be in place to enable sample location and for performing inventory. The samples should remain in LN<sub>2</sub> during the duration of inventory performance and the audit must be performed by qualified and skilled staff.

Several facility and equipment-related quality control and risks factors must be considered for cryopreservation and storage of semen. Physical security of bank facilities and proper identification of sample location within freezers is crucial. Equipment must be appropriate and functional, with defined periodic service and maintenance schedules. Staff must be supplied with all necessary personal protective equipment. Adequate supplies of LN<sub>2</sub> gas must be guaranteed and spare LN<sub>2</sub> prefilled tank must be available in case of emergency. All staff involved in handling LN<sub>2</sub> must be properly trained by a certified organization. Standard operating procedures must be developed to clearly describe each step of the process of sample collection, processing, banking and handling. Annual reviews of both proper documentation and LN<sub>2</sub> training must be performed. Temperature of freezers chambers and LN<sub>2</sub> levels in tanks must be monitored on a continuous basis and all data logged in secure databases. Alarm systems and appropriate call procedures must be in place to attend to any emergencies. 24 hour monitoring and response is absolutely essential to safely maintain the integrity of the clinical samples in storage. Storage rooms must be monitored continuously for O<sub>2</sub> levels and staff activity in enclosed spaces must be monitored to avoid hypoxic injury. Backup power generation must be available in the event of a power failure. Each sample designated for storage has to be properly verified, assessed, processed, labelled, frozen and stored. Double-checking the identity of samples at each step is highly recommended. Some banks choose to divide samples from individual patients or couples and store them in different tanks or locations to minimize the risk of total loss of their biologic material (WHO, 2010).

### **5. Sperm donation**

#### **5.1 Applications for sperm donation**

In cases of severe male infertility, single or lesbian women, the use of donor sperm is the only approach to address fertility issues (Botchan et al., 2001; Golombok, 2005). Advances in

sperm cryopreservation have created opportunities for many families to achieve pregnancies through therapeutic donor insemination or IVF with donor sperm. Pregnancy rates are estimated to be around 10-12% per unstimulated cycle and can be achieved when at least  $5 \times 10^6$  progressively motile spermatozoa inseminated into the lower cervical canal on 2-3 occasions during the ovulatory phase of menstrual cycle (Scott et al., 1990). At present, some 30,000 births per year worldwide are attributable to frozen donor sperm inseminations (Mortimer, 2004). While this seems like a large number, it may fall in the future, as the recruitment of sperm donors is increasingly difficult due to complicated and strict regulatory procedures, as well as lack of interest from potential donors.

The screening process for donor sperm is quite rigorous and includes obtaining a complete medical and sexual history, physical examination, psychological assessment and laboratory work-up on blood, urine and semen specimens to screen for pathogens including Hepatitis B, C, Human Immunodeficiency Virus (HIV 1&2), Human T-cell Lymphotropic Virus (HTLV 1&2), *Treponema pallidum* (Syphilis), Cytomegalovirus, *Chlamydia trachomatis* and *Neisseria gonorrhoea*. Sperm banks perform genetic screening for heritable diseases based on the ethnic background of sperm donors (eg. Cystic Fibrosis for Caucasians). Donors must be retested after the required quarantine interval, and specimens may be released only if the results of repeat testing are negative. Specimens can only be used after they have been quarantined for a minimum of 180 days to avoid the risk of HIV transmission. Donor eligibility restrictions apply to employees of sperm banks, poor donors' health or quality of the semen and in some countries by sexual orientation of the donor, as gay or bisexual men are considered at higher risk for HIV and prohibited from being sperm donors in some countries (including Canada and USA). Many countries have age restrictions for sperm donation. The minimum age is usually 18 and the maximum 40 years of age (Health Canada 2000, American Society for Reproductive Medicine (ASRM), 2004)

## 5.2 Anonymous donors

Semen donors can be classified into two specific groups, anonymous and non-anonymous (known). Currently, with the establishment of many commercial sperm banks and the ability to safely transport samples even between continents, anonymous sperm donation is the method of choice for most recipients. The anonymity of the donor is maintained through the process. This is an important issue to both the recipient and the donor (Ernst et al., 2007). For fully anonymous sperm donation, the recipients would not be known to the donor and the donor offspring would have no future contact with the donor. The sperm donor gives up all legal rights over the biological children conceived from his samples donated to sperm bank. Anonymous donation allows parents, if they wish, to conceal the issue of infertility, or the fact of non-genetic parenting from the offspring. The motivation to hide this information most commonly is driven by pressure from other family members; fear of being rejected by the child or to protect children from the complicated psychosocial matters related to sperm donation. In many Western countries disclosure is encouraged by many counsellors, and if open disclosure is chosen by the parents, it is usually advised to disclose the method of conception to their children at an early age. Non-disclosure by parents of the biological origin of their children is viewed by some as misleading the child and could potentially affect trust between parents and their children, if their origin eventually becomes known to the child (Patrizio et al., 2001). However, it is ultimately the decision of the parents to disclose or not as in adoption cases.

There is some consensus that there should be limits on the number of offspring allowed from a given sperm donor. This is driven by possibility of accidental consanguinity between children from the same sperm donor. For example ASRM recommends a limit of 25 children per population of 800 000 for a single donor, but there are no federal or state laws limiting the number of sperm donation by a donor. In UK the number is limited to 10 different families, but does not apply if a genetically related sibling for an existing child is desired. Some countries limit the number of children to 4 in New Zealand; 5 in China; and 5 to 10 in Australia depending on the region; 25 in the Netherlands (Gong et al., 2009).

Recently, open-identity sperm donors have become available through many sperm banks. These donors have agreed to at least a single contact with any children born through use of their sperm, usually when the child reaches the age of consent (18 years old in most jurisdictions), for those individuals who wish to contact them (Gottlieb et al., 2000; Frith et al., 2007). In some cases audio interviews and pictures are available from these donors.

Two types of anonymous donor samples are usually available through sperm banks, prewashed or unwashed: Prewashed samples are obtained by processing the ejaculate by density gradient centrifugation for seminal fluid removal prior to freezing and can be directly inseminated into the uterine cavity after thawing (Larson et al. 1997). These samples are favoured by doctors' offices without access to an Andrology laboratory for post thaw processing. For processing unwashed samples, density gradient isolation is required to remove contaminants and CPAs after thawing the specimen prior to intrauterine insemination or for IVF. The removal of CPAs has to be performed step-by-step and gradually to minimize osmotic stress on spermatozoa. Drop-wise dilution of the sample with 1:10 sample to sperm wash medium ratio is recommended (Mortimer, 2004).

### **5.3 Non-anonymous sperm donors**

Some donors and recipients choose to arrange donations privately and the donor in this case is known to the recipient(s). The donor may be a family member such as a brother or father or a friend. Most of these donations are done altruistically and acceptable only if all parties are in agreement. All participants involved in the donation process are generally required to attend a separate and a joint counselling session. An initial counselling interview with the donor and his spouse or partner (if applicable) is arranged to discuss the personal, social and legal aspects of donation. The known donor has to meet all requirements to be accepted for donation and undergo the same screening tests and laboratory evaluation as an anonymous donor, including 180 days quarantine for his frozen sample. Proper consent and declaration forms are required to be signed by known semen donor. Furthermore, a child conceived using donated semen is legally deemed to be the child of the recipient(s), and the donor has no legal rights or responsibilities regarding the child. Usually the donor may at any time prior to the use of his semen, vary or revoke his consents. Most clinics require a legal contract with all parties having received independent legal advice. As the use of the third party reproduction such as sperm and egg donation becomes more acceptable in many countries the ethical and legal aspects of these procedures become increasingly important. Issues of the donor's anonymity, financial compensation, religion and cultural acceptance, regulation of donor and prospective parent screening, as well as consideration of the welfare of children conceived with the use of donor sperm are widely discussed in the scientific literature and public media. While guidelines on the use of donated sperm come from



government or professional organizations, they may also be influenced by religious institutions and they vary widely from country to country (Gong, 2009).

## **6. Social importance and psychological aspects around banking oncology patients, adolescent and young adults**

When an individual is diagnosed with cancer almost every aspect of their physical and psychosocial well-being is altered. Quite often in clinical practice, the long term effects of cancer therapy on a patients' ability to have children in the future is not adequately addressed (Thaler-DeMers, et al., 2001). While the priority is to eliminate the cancer and save their life, fertility preservation especially among adolescent or young adults to ensure the potential of procreation with their own gametes after treatment, needs to be considered. Impaired spermatogenesis has been demonstrated before treatment in some patients with malignancies, depending on their location (eg. testicular cancer) or type (eg. Hodgkin's lymphoma) (Rueffer et al., 2001). Current treatment options such as surgery, chemotherapy and/or radiation can impair spermatogenesis and sexual function and lead to temporary or permanent infertility (Magelssen et al., 2006).

The scale of negative effects of cancer treatment on spermatogenesis depend on the specific gonadotoxicity of administered chemotherapeutic agents, number of chemotherapy treatment cycles, radiotherapy field location and dosage, type and stage of the cancer, and age of the patient. Considering combination cancer therapy, uncertainty in individual response to treatment and the large number of confounding variables, it becomes very challenging to assess the risk of iatrogenic infertility in many patients. The ability of cancer survivors to have their own biological offspring is very important for many oncology patients, especially at younger ages (Schover et al., 1999). Advances in early diagnostic investigation and treatments have led to increasing numbers of young cancer survivors. Unfortunately up to 30% of childhood cancer survivors are permanently sterile following cancer treatment (Tournaye et al., 2004). In Canada and the United States, cancer in patients 15 to 29 years of age who can benefit from sperm banking is nearly three times more common than in patients younger than 14 years (Bleyer et al., 2006). Early germ cells, (spermatogonia) are very sensitive to radiation and chemotherapy. Even low doses or a single dose treatment can potentially cause functional impairment of spermatogenesis. With increase in dosage or duration of the treatment, initially spermatocytes get damaged and as treatment progresses spermatids also become damaged. Radiation doses of less than 0.8 Gy can result in oligospermia and doses between 0.8 and 3 Gy can result in azoospermia (Rivkees & Crawford, 1988).

Cryopreservation of semen has changed the reproductive prospects for young patients diagnosed with cancer. Unfortunately, banking services continue to be underutilized since cancer patients and their families are not always informed about the potential fertility risks associated with cancer treatments, or the availability of banking. According to some surveys, less than 20% of patients undergoing chemotherapy or radiation treatment are informed about the adverse effects of such treatment on spermatogenesis or are offered sperm banking for fertility preservation. Cancer patients are usually under huge physiological and time pressure to make cryopreservation decisions while dealing with a life threatening situation. To complicate matters, some young patients are unable to produce semen samples by masturbation. In such cases, PVS or electro-ejaculation under general anaesthetic might be required. Surgical retrieval of testicular tissue may be an option for

prepubertal boys who are not capable of producing mature sperm. Testicular tissue cryopreservation has been reported in boys with cryptorchidism to preserve fertility (Bahadur et al., 2000). Cryopreserved testicular tissues can be autografted to restore reproductive functions; however recurrence of neoplastic process is a concern in oncology patients and such procedures are still considered to be experimental (Hwang & Lamb, 2010). A multi-disciplinary team approach is important to ensure that patients have the opportunity to preserve their fertility potential if they elect to do so.

The posthumous use of semen is an entirely separate and complex ethico-legal subject. The ethical and legal aspects of posthumous assisted reproduction have been recently addressed by the European Society of Human Reproduction and Embryology Task Force on Ethics and Law (ESHRE, 2006).

## 7. Conclusions

Human spermatozoa can be successfully cryopreserved and utilized. Cryopreservation now plays an essential role in fertility preservation under the following scenarios:

- couples undergoing infertility treatment.
- cancer patients undergoing gonadotoxic chemotherapy or radiation.
- patients undergoing certain types of pelvic or testicular surgeries
- patients suffering from degenerative illnesses such as diabetes or multiple sclerosis; spinal cord disease or injury.
- men undergoing surgical sterilization such as vasectomy
- screening and quarantine of donor semen samples

Normozoospermic semen samples appear to be more tolerant to damage induced by freezing and thawing compared with oligozoospermic or asthenozoospermic samples. Cryopreservation of surgically retrieved epididymal and testicular spermatozoa is challenging, but a valuable component in effective treatment and management of severe male factor infertility. Cryopreservation of low numbers or single spermatozoa has multiple biological and technical aspects yet to be worked out; therefore, further research is required to introduce this technique into clinical practice. During cryopreservation, cells and tissue undergo dramatic transformation in chemical and physical characteristics as temperature drops from +37 to -196°C, thus risking cryoinjury. Velocity of cooling and warming is crucial and inaccurate cooling or thawing rates negatively correlate with sperm survival.

Spermatozoa cannot survive slow freezing without CPAs; CPAs have to be used at low concentrations with minimum exposure as CPAs are toxic and can cause osmotic damage. Gradual, stepwise introduction before freezing and removal of CPAs after thawing is essential. Conventional slow freezing with CPAs can offer cooling rates of 1-10°C/min. Vitrification, currently only an experimental technique, allows for extremely rapid freezing at rates of up to a 1000°C/min. LN<sub>2</sub> can offer long-term survival of spermatozoa due to essentially absent metabolic activity and aging of cells and tissues in the frozen state. Rigorous standards of operation and quality control are essential for sperm banks. Social, psychological, legal and ethical issues surrounding sperm banking are very complex and must be considered in each case.

The vitrification method uses no specially developed cooling program; it does not need permeable cryoprotectants; it is much faster, simpler and cheaper; and it can also provide a

high recovery of motile spermatozoa after warming as effective protection of spermatozoa against cryodamage and helps to avoid many problems relevant to slow freezing such as ice formation; shifts in pH, extensive rehydration and osmotic damage.

Successful vitrification of human spermatozoa without toxic CPAs has been reported now by two independent groups. Moreover, live births were reported after vitrification of semen utilized for intrauterine insemination and IVF with ICSI procedures, making this freezing technique even more attractive in clinical practice.

## 8. References

- Abdel Hafez, F.; Bedaiwy, M.; El-Nashar, S.A.; Sabanegh, E. & Desai, N. (2009). Techniques for cryopreservation of individual or small numbers of human spermatozoa: a systematic review. *Human Reproduction Update*, 15(2), pp. 153-164, ISSN 1460-2369
- Arakawa, T.; Carpenter, J.F.; Kita, Y.A. & Crowe, J.H. (1990). The basis for toxicity of certain cryoprotectants. *Cryobiology*, 27, pp. 401-415, ISSN 0011-2240
- Bahadur, G.; Chatterjee, R. & Ralph, D. (2000). Testicular tissue cryopreservation in boys. Ethical and legal issues. *Human Reproduction*, 15(6), pp. 1416-1420, ISSN 0268-1161
- Bahadur, G.; Whelan, J.; Ralph, D. & Hindmarsh P. (2001). Gaining consent to freeze spermatozoa from adolescents with cancer: legal, ethical and practical aspects. *Human Reproduction*, 16(1), pp. 188-193, ISSN 0268-1161
- Bleyer, A.; Budd, T. & Montello, M. (2006). Adolescents and young adults with cancer: the scope of the problem and criticality of clinical trials. *Cancer*, 107 (Suppl. 7), pp. 1645-1655, ISSN 1097-0142
- Borges, E. Jr.; Rossi, L.M.; Locambo de Freitas, C.V.; Guilherme, P.; Bonetti, T.C.; Iaconelli, A. & Pasqualotto, F.F. (2007). Fertilization and pregnancy outcome after intracytoplasmic injection with fresh or cryopreserved ejaculated spermatozoa. *Fertility and Sterility*, 87(2), pp. 316-320, ISSN 1556-5653
- Botchan, A.; Hauser, R.; Gamzu, R.; Yogev, L.; Paz, G. & Yavetz, H. (2001). Results of 6139 artificial insemination cycles with donor spermatozoa. *Human Reproduction*, 16, pp. 2298-2304 ISSN 0268-1161
- Brackett, N.L.; Ferrell, S.M.; Aballa, T.C.; Amador, M.J.; Padron, O.F.; Sonksen, J. & Lynne, C.M. (1998). An analysis of 653 trials of penile vibratory stimulation in men with spinal cord injury. *The Journal of Urology*, 159(6), pp. 1931-1934, ISSN 0022-5347
- British Andrology Society. (1999). *British Andrology Society guidelines for the screening of semen donors for donor insemination*, ISSN 0268-1161
- Clarke, G. (1999). Sperm cryopreservation: is there a significant risk of cross-contamination? *Human Reproduction*, 14, pp. 2941-2943, ISSN 0268-1161
- Cohen, J.; Garrisi, G.J.; Congedo-Ferrara, T.A.; Kieck, K.A.; Schimmel, T.W. & Scott, R.T. (1997). Cryopreservation of single human spermatozoa. *Human Reproduction*, 12(5), pp. 994-1001, ISSN 0268-1161
- Craft, I.; Tsirigotis, M.; Bennett, V.; Taranissi, M.; Khalifa, Y.; Hogewind, G. & Nicholson, N. (1995). Percutaneous epididymal sperm aspiration and intracytoplasmic sperm injection in the management of infertility due to obstructive azoospermia. *Fertility and Sterility*, 63(5), pp. 1038-1042, ISSN 0015-0282
- Curry, M.R. & Watson, P.E. (1994). Osmotic effects on ram and human sperm membranes in relation to thawing injury. *Cryobiology*, 31, pp. 39-46, ISSN 0011-2240
- de Paula, T.S.; Bertolla, R.P.; Spaine, D.M.; Cunha, M.A.; Schor, N. & Cedenho, A.P. (2006). Effect of cryopreservation on sperm apoptotic deoxyribonucleic acid fragmentation

- in patients with oligozoospermia *Fertility and Sterility*, 86(3), pp. 597-600, ISSN 1556-5653
- Denil, J.; Kuczyk, M.A.; Schultheiss, D.; Jibril, S.; K pker, W.; Fischer, R.; Jonas, U.; Schl sser H.W. & Diedrich, K. (1996). Use of assisted reproductive techniques for treatment of ejaculatory disorders. *Andrologia*, 28 (Suppl. 1), pp 43-51, ISSN 0303-4569
- Desai, N.N.; Blackmon, H. & Goldfarb, J. (2004). Single sperm cryopreservation on cryoloops: an alternative to hamster zona for freezing individual spermatozoa. *Reproductive Biomedicine Online*, 9, pp. 47-53, ISSN 1472-6483
- Devireddy, R.V.; Swanlund, D.J.; Roberts, K.P.; Pryor, J.L. & Bischof, J.C. (2000). The effect of extracellular ice and cryoprotective agents on the water permeability parameters of human sperm plasma membrane during freezing. *Human Reproduction* 15(5), pp. 1125-1135, ISSN 0268-1161
- Donnelly, E.T.; Steele, E.K.; McClure, N. & Lewis, S.E. (2001). Assessment of DNA integrity and morphology of ejaculated spermatozoa from fertile and infertile men before and after cryopreservation. *Human Reproduction*, 16(6), pp. 1191-1199, ISSN 0268-1161
- Duty, S.M.; Singh, N.P.; Ruan, L.; Chen, Z.; Lewis, C.; Huang, T. & Hauser, R. (2002). Reliability of the comet assay in cryopreserved human sperm. *Human Reproduction* 17(5), pp. 1274-1280, ISSN 0268-1161
- Ernst, E.; Ingerslev, H.J.; Schou, O. & Stoltenberg, M. (2007). Attitudes among sperm donors in 1992 and 2002: a Danish questionnaire survey. *Acta Obstetricia et Gynecologica Scandinavica*, 86, pp. 327-333, ISSN 0001-6349
- ESHRE Task Force on Ethics and Law 11: Posthumous assisted reproduction (2006). *Human Reproduction*, 21(12), pp. 3050-3053, ISSN 0268-1161
- Fahy, G.M. (1986) The relevance of cryoprotectant "toxicity" to cryobiology. *Cryobiology*, 23, pp. 1-13, ISSN 011-2240
- Foreman, D.M. (1999). The family rule: a framework for obtaining ethical consent for medical interventions from children. *Journal of Medical Ethics*, 25, pp. 491-496, ISSN 0306-6800
- Fountain, D.; Ralston, M.; Gorlin, J.B.; Uhl, L.; Wheeler, C.; Antin, J.H.; Churchill, W.H. & Benjamin, R.J. (1997). Liquid nitrogen freezers: a potential source of microbial contamination of hematopoietic stem cell components. *Transfusion*, 37, pp. 585-591, ISSN 0041-1132
- Frith, L.; Blyth, E. & Farrand, A. (2007). UK gamete donors' reflections on the removal of anonymity: implications for recruitment. *Human Reproduction*, 22(6), pp. 1675-1680, ISSN 0268-1161
- Fujikawa, S. & Miura, K. (1986). Plasma membrane ultrastructural changes caused by mechanical stress in the formation of extracellular ice as a primary cause of slow freezing injury in fruit-bodies of basidiomycetes (*Lyophyllum ulmariuum*). *Cryobiology*, 23, pp. 371-382, ISSN 0386-7196
- Gil-Salom, M.; Romero, J.; Rubio, C.; Ruiz, A.; Remohi, J. & Pellicer, A. (2000). Intracytoplasmic sperm injection with cryopreserved testicular spermatozoa. *Molecular and Cellular Endocrinology*, 169, pp. 15-19, ISSN 0303-7207
- Golombok, S. (2005). Unusual families. *Reproductive Biomedicine Online*, 10 (Suppl. 1), pp. 9-12, ISSN 1472-6483
- Gong, D.; Liu, Y.L.; Zheng, Z.; Tian, Y.F. & Li, Z. (2009). An overview on ethical issues about sperm donation. *Asian Journal of Andrology*, 11(6), pp. 645-652, ISSN 1745-7262

- Gosálvez, J.; Cortés-Gutiérrez, E.; López-Fernández, C.; Fernández, J.L.; Caballero, P. & Nuñez, R. (2009). Sperm deoxyribonucleic acid fragmentation dynamics in fertile donors. *Fertility and Sterility*, 92, pp. 170-173, ISSN 1556-5653
- Gottlieb, C.; Lalos, O. & Lindblad, F. (2000). Disclosure of donor insemination to the child: the impact of Swedish legislation on couples' attitudes. *Human Reproduction*, 15(9), pp. 2052-2056, ISSN 0268-1161
- Hammadeh, M.E.; Askari, A.S.; Georg, T.; Rosenbaum, P. & Schmidt, W. (1999). Effect of freeze-thawing procedure on chromatin stability, morphological alteration and membrane integrity of human spermatozoa in fertile and subfertile men. *International Journal of Andrology*, 22(3):155-162, ISSN 0105-6263
- Hauser, R.; Yogev, L.; Paz, G.; Yavetz, H.; Azem, F.; Lessing, J.B. & Botchan, A. (2006). Comparison of efficacy of two techniques for testicular sperm retrieval in nonobstructive azoospermia: multifocal testicular sperm extraction versus multifocal testicular sperm aspiration. *Journal of Andrology*, 27, pp. 28-33, ISSN 0196-3635
- Health Canada. (2000). *Technical Requirements for Therapeutic Donor Insemination. Therapeutic Products Programme*, Health Canada, Ottawa, Canada, [http://www.hc-sc.gc.ca/dhp-mps/brgtherap/applic-demande/guides/semen-sperme-acces/semen-sperme\\_directive-eng.php](http://www.hc-sc.gc.ca/dhp-mps/brgtherap/applic-demande/guides/semen-sperme-acces/semen-sperme_directive-eng.php)
- Health Canada, *Therapeutic Products Programme Guidance on the Donor Semen Special Access Programme (DSSAP)*, Health Canada, Ottawa, Canada. (2011). [http://www.hc-sc.gc.ca/dhp-mps/brgtherap/applic-demande/guides/semen-sperme-acces/dssap-passd\\_gui\\_doc-ori-eng.php](http://www.hc-sc.gc.ca/dhp-mps/brgtherap/applic-demande/guides/semen-sperme-acces/dssap-passd_gui_doc-ori-eng.php)
- Henry, M.A.; Noiles, E.E.; Gao, D.; Mazur, P. & Critser, J.K. (1993). Cryopreservation of human spermatozoa. The effects of cooling rate and warming rate on the maintenance of motility, plasma membrane integrity, and mitochondrial function. *Fertility and Sterility*, 60(5), pp. 911-918, ISSN 0015-0282
- Herrler, A.; Eisner, S.; Bach, V.; Weissenborn, U. & Beier, H.M. (2006). Cryopreservation of spermatozoa in alginate acid. *Fertility and Sterility*, 85(1), pp. 208-213, ISSN 1556-5653
- Holt, W.V. (2000). Fundamental aspects of sperm cryobiology: the importance of species and individual differences. *Theriogenology*, 53, pp. 47-58, ISSN 0093-691X
- Hovatta, O. (2003). Cryobiology of ovarian and testicular tissue. *Best Practice & Research Clinical Obstetrics & Gynaecology*, 17(2), pp. 331-342, ISSN 1521-6934
- Hovav, Y.; Almagor, M. & Yaffe, H. (2002). Comparison of semen quality obtained by electroejaculation and spontaneous ejaculation in men suffering from ejaculation disorder. *Human Reproduction*, 17(12), pp. 3170-3172, ISSN 0268-1161
- Hwang, K. & Lamb, D.J. (2010). New advances on the expansion and storage of human spermatogonial stem cells. *Current Opinion in Urology*, 20(6), pp. 510-514, ISSN 1473-6586
- Isaev, D.A.; Zaletov, S.Y.; Zaeva, V.V.; Zakharova, E.E.; Shafei, R.A. & Krivokharchenko, I.S. (2007). Artificial microcontainers for cryopreservation of solitary spermatozoa. *Human Reproduction*, 22, pp. i154, (*Abstracts of the 23rd Annual Meeting of the ESHRE*, Lyon, France, 2007)
- Isachenko, E.; Isachenko, V.; Katkov, I.I.; Dessole, S. & Nawroth, F. (2003). Vitrification of mammalian spermatozoa in the absence of cryoprotectants: from past practical difficulties to present success. *Reproductive Biomedicine Online*, 6(2), pp. 191-200, ISSN 1472-6483
- Isachenko, E.; Isachenko, V.; Sanchez, R.; Katkov, I.I. & Kreienberg, R. (2011). Cryopreservation of spermatozoa. Old routine and new perspectives, In: *Principles*

- and Practice of Fertility Preservation*, J. Donnez & S.S. Kim (Ed.), pp. 177-198, Cambridge University Press, ISBN 978-953-7619-81-7, Cambridge, UK
- Isachenko, E.; Isachenko, V.; Weiss, J.M.; Kreienberg, R.; Katkov, I.I.; Schulz, M.; Lulat, A.G.; Risopatrón, M.J. & Sánchez, R. (2008). Acrosomal status and mitochondrial activity of human spermatozoa vitrified with sucrose. *Reproduction*, 136(2), pp. 167-73, ISSN 1741-7899
- Isachenko, V.; Isachenko, E.; Katkov, I.I.; Montag, M.; Dessolet, S.; Nawroth, F. & Van der Ven, H. (2004). Cryoprotectant-free cryopreservation of human spermatozoa by vitrification and freezing in vapor: effect on motility, DNA integrity, and fertilization ability. *Biology of Reproduction*, 71, pp. 1167-1173, ISSN 0006-3363
- Isachenko, V.; Isachenko, E.; Montag, M.; Zaeva, V.; Krivokharchenko, I.; Nawroth, F.; Dessolet, S.; Katkov I.I. & Van der Ven, H. (2005). Clean technique for cryoprotectant-free vitrification of human spermatozoa. *Reproductive Biomedicine Online*, 10(3), pp. 350-354, ISSN 472-6483
- Just, A.; Gruber, I.; Wober, M.; Lahodny, J.; Obruca, A. & Strohmer, H. (2004). Novel method for the cryopreservation of testicular sperm and ejaculated spermatozoa from patients with severe oligospermia: a pilot study. *Fertility and Sterility*, 82, pp. 445-447, ISSN 0015-0282
- Katkov, I.I. (2002). The point of maximum cell water volume excursion in case of presence of an impermeable solute. *Cryobiology* 44, pp. 193-203, ISSN 0011-2240
- Katkov, I.I.; Isachenko, V.; Isachenko, E.; Kim, M.S.; Lulat, A.G.-M.I.; Mackay, A.M. & Levine, F. (2006). Low- and high-temperature vitrification as a new approach to biostabilization of reproductive and progenitor cells. *International Journal of Refrigeration*, 29, pp. 346-357 ISSN 0140-7007
- Katkov, I.I.; Katkova, N.; Critser, J.K. & Mazur, P. (1998). Mouse spermatozoa in high concentrations of glycerol: chemical toxicity vs osmotic shock at normal and reduced oxygen concentration. *Cryobiology*, 37, pp. 235-338, ISSN 0011-2240
- Katkov, I.I. & Lulat, A.G. (2000). Do conventional CASA-parameters reflect recovery of kinematics after freezing? CASA paradox in the analysis of recovery of spermatozoa after cryopreservation. *CryoLetters* 21(3), pp. 141-148, ISSN 0143-2044
- Koshimoto, C.; Gamliel, E. & Mazur, P. (2000). Effect of osmolality and oxygen tension on the survival of mouse sperm frozen to various temperatures in various concentrations of glycerol and raffinose. *Cryobiology*, 41, pp. 204-231, ISSN 0011-2240
- Lania, C.; Grasso, M.; Fortuna, F.; De Santis, L. & Fusi, F. (2006). Open epididymal sperm aspiration (OESA): minimally invasive surgical technique for sperm retrieval. *Archivos españoles de urología*, 59, pp. 313-316, ISSN 0004-0614
- Larson, J.M.; McKinney, K.A.; Mixon, B.A.; Burry, K.A. & Wolf, D.P. (1997). An intrauterine insemination-ready cryopreservation method compared with sperm recovery after conventional freezing and post-thaw processing. *Fertility and Sterility*, 68, pp. 143-148, ISSN 0015-0282
- Lasso, J.L.; Noiles, E.E.; Alvarez, J.G. & Storey, B.T. (1994). Mechanism of superoxide dismutase loss from human sperm cells during cryopreservation. *Journal of Andrology*, 15, pp. 255-265, ISSN 0196-3635
- Magelssen, H.; Brydoy, M. & Fossa, S. D. (2006). The effects of cancer and cancer treatments on male reproductive function. *Nature Clinical Practice Urology*, 3(6), pp. 312-322, ISSN 1743-4270
- Mazur, P. (1984). Freezing of living cells: mechanisms and implications. *American Journal of Physiology*, 247, pp. 125-142, ISSN 0002-9513

- Mazur, P.; Leibo, S.P. & Chu, E.H. (1972). A two factor hypothesis of freezing injury - evidence from Chinese hamster tissue culture cells. *Experimental Cell Research*, 71, pp. 345-355, ISSN 0014-4827
- McGann, L.E. & Farrant, J. (1976). Survival of tissue culture cells frozen by a two-step procedure to -196°C. Holding temperature and time. *Cryobiology*, 13, pp. 261-268, ISSN 0011-2240
- Morris, G.J.; Acton, E. & Avery, S. (1999). Novel approach to sperm cryopreservation. *Human Reproduction*, 14(4), pp. 1013-1021, ISSN 0268-1161
- Mortimer, D. (2004). Current and future concepts and practices in human sperm cryobanking. *Reproductive Biomedicine Online*, 9, pp. 134-151, ISSN 1472-6483
- Moskovtsev, S.I.; Jarvi, K.; Mullen, J.B.; Cadesky, K.I.; Hannam, T. & Lo, K.C. (2010). Testicular spermatozoa have significantly lower DNA damage compared to ejaculated spermatozoa in patients with unsuccessful oral antioxidant treatment. *Fertility and Sterility* 93(4), pp. 1142-1146, ISSN 1556-5653
- Moskovtsev, S.I.; Kuznyetsov, V.; Spiridonov, S; Lulat, A.; Crowe, M. & Librach, C.L. (2011). Comparison of vitrification and slow vapor protocols for cryopreservation of human spermatozoa. In: *Materials of 57th Canadian Fertility and Andrology Society Annual Meeting*, pp. 119, Toronto, Ontario, Canada, September 21- 24 2011
- Moskovtsev, S.I; Willis, J; White, J. & Mullen, J.B. (2009). Sperm DNA damage: correlation to severity of semen abnormalities. *Urology*, 74(4), pp. 789-793, ISSN 527-9995
- Mossad, H.; Morshedi, M.; Torner, J.P. & Oehninger, S. (1994). Impact of cryopreservation on spermatozoa from infertile men – implication for artificial insemination. *Archives of Andrology*, 33, pp. 51–57, ISSN 0148-5016
- Nawroth, F.; Isachenko, V.; Dessole, S.; Rahimi, G.; Farina, M.; Vargiu, N.; Mallmann, P.; Dattena, M.; Capobianco, G.; Peters, D.; Orth, I. & Isachenko, E. (2002). Vitrification of human spermatozoa without cryoprotectants. *CryoLetters*, 23, pp. 93-102, ISSN 0143-2044
- Nicopoulos, J.D.; Ramsay, J.W.; Almeida, P.A. & Gilling-Smith, C. (2004). Assisted reproduction in the azoospermic couple. *An International Journal of Obstetrics and Gynaecology*, 111, pp. 1190-1203, ISSN 1470-0328
- O'Connell, M.; McClure, N. & Lewis, S.E.M. (2002). The effects of cryopreservation on sperm morphology, motility and mitochondrial function. *Human Reproduction*, 17(6), pp. 704-709, ISSN 0268-1161
- Patrizio, P.; Mastroianni, A.C. & Mastroianni, L. (2001). Disclosure to children conceived with donor gametes should be optional. *Human Reproduction*, 16(10), pp. 2036-2038, ISSN 0268-1161
- Rivkees, S.A. & Crawford, J.D. (1988). The relationship of gonadal activity and chemotherapy-induced gonadal damage. *The Journal of the American Medical Association*, 259, pp. 2123-21255, ISSN 0098-7484
- Rueffer, U.; Breuer, K.; Josting, A.; Lathan, B.; Sieber, M.; Manzke, O.; Grotenhermen, F.J.; Tesch, H.; Bredenfeld, H.; Koch, P.; Nisters-Backes, H.; Wolf, J.; Engert, A. & Diehl, V. (2001). Male gonadal dysfunction in patients with Hodgkin's disease prior to treatment. *Annals of Oncology*, 12(9), pp. 1307-1311, ISSN 0923-7534
- Said, T.M.; Gaglani, A. & Agarwal A. (2010). Implication of apoptosis in sperm cryoinjury. *Reproductive Biomed Online* 21(4), pp. 456-462, ISSN 1472-6491
- Sanchez, R.; Isachenko, V.; Petrunkina, A.M.; Risopatron, J.; Schulz, M. & Isachenko, E. (2011). Live Birth after Intrauterine Insemination with Spermatozoa from an Oligo-Astheno-Zoospermic Patient Vitrified Without Permeable Cryoprotectants. *Journal of Andrology (in press)*, ISSN 1939-4640

- Schlegel, P.N. & Su, L.M. (1997). Physiological consequences of testicular sperm extraction. *Human Reproduction*, 12(8), pp. 1688-1692, ISSN 0268-1161
- Schlegel, P.N.; Palermo, G.D.; Goldstein, M.; Menendez, S.; Zaninovic, N.; Veeck, L.L. & Rosenwaks, Z. (1997). Testicular sperm extraction with intracytoplasmic sperm injection for nonobstructive azoospermia. *Urology*, 49, pp. 435-440, ISSN 0090-4295
- Schover, L.R.; Rybicki, L.A.; Martin, B.A. & Bringelsen, K.A. (1999). Having children after cancer. A pilot survey of survivors' attitudes and experiences. *Cancer*, 86(4), pp. 697-709, ISSN 0008-543X
- Schuster, T.G.; Keller, L.M.; Dunn, R.L.; Ohl, D.A. & Smith, G.D. (2003). Ultra-rapid freezing of very low numbers of sperm using cryoloops. *Human Reproduction*, 18(14), pp. 788-795, ISSN 0268-1161
- Sereni, E.; Bonu, M.A.; Fava, L.; Sciajno, R.; Serrao, L.; Preti, S.; Distratis, V. & Borini, A. (2008). Freezing spermatozoa obtained by testicular fine needle aspiration: a new technique. *Reproductive Biomedicine Online*, 16, pp. 89-95, ISSN 1472-6483
- Shimada, K. & Asahina, E. (1975). Visualization of intracellular ice crystals formed in very rapidly frozen cells at -27 degree C. *Cryobiology*, 12(3), pp. 209-218, ISSN 0011-2240
- Thaler-DeMers, D. (2001). Intimacy issues: sexuality, fertility, and relationships. *Seminars in Oncology Nursing*, 17(4), pp. 255-262, ISSN 0749-2081
- The American Society for Reproductive Medicine. (2004). Guidelines for sperm donation. *Fertility and Sterility*, 82, pp. S9-12, ISSN 0015-0282
- Tomlinson, M. & Sakkas, D. (2000). Is a review of standard procedures for cryopreservation needed? Safe and effective cryopreservation—should sperm banks and fertility centres move toward storage in nitrogen vapour? *Human Reproduction*, 15(12), pp. 2460-2463, ISSN 0268-1161
- Tomlinson, M. (2005) Managing risk associated with cryopreservation. *Human Reproduction*, 20, pp. 1751-1756, ISSN 0268-1161
- Thomson, L.K.; Fleming, S.D.; Aitken, R.J.; De Iuliis, G.N.; Zieschang, J.A. & Clark, A.M. (2009). Cryopreservation-induced human sperm DNA damage is predominantly mediated by oxidative stress rather than apoptosis. *Human Reproduction* 24(9), pp. 2061-2070, ISSN 1460-2350
- Tournaye, H.; Goossens, E.; Verheyen, G.; Frederickx, V.; De Block, G.; Devroey, P. & Van Steirteghem, A. (2004). Preserving the reproductive potential of men and boys with cancer: current concepts and future prospects. *Human Reproduction Update*, 10(6), pp. 525-532, ISSN 1355-4786
- Tyler, J.P.; Kime, L.; Cooke, S. & Driscoll, G.L. (1996). Temperature change in cryocontainers during short exposure to ambient temperatures. *Human Reproduction*, 11(7), pp. 1510-1512, ISSN 0268-1161
- Verza, Jr. S.; Feijo, C.M. & Esteves, S.C. (2009). Resistance of human spermatozoa to cryoinjury in repeated cycles of thaw-refreezing. *International Brazilian Journal of Urology*, 35, pp. 581-590, ISSN 1677-6119
- Walmsley, R.; Cohen, J.; Ferrara-Congedo, T.; Reing, A. & Garrisi J. (1998). The first births and ongoing pregnancies associated with sperm cryopreservation within evacuated egg zona. *Human Reproduction*, 13 (Suppl. 4), pp. 61-70, ISSN 0268-1161
- Woods, E.J.; Benson, J.D.; Agca, Y. & Critser, J.K. (2004). Fundamental cryobiology of reproductive cells and tissues. *Cryobiology*, 48, pp. 146-156, ISSN 0011-2240
- World Health Organization (1999). *WHO laboratory manual for the examination of human semen and sperm-cervical mucus interaction*, pp. 169-179, 4th ed. Cambridge University Press, ISBN 978-924-154-778-9, Cambridge, UK



# Prevention of Lethal Osmotic Injury to Cells During Addition and Removal of Cryoprotective Agents: Theory and Technology

Dayong Gao<sup>1</sup> and Xiaoming Zhou<sup>2</sup>

<sup>1</sup>*University of Washington, Seattle, WA*

<sup>2</sup>*University of Electronic Science and Technology of China, Chengdu,*

<sup>1</sup>*USA*

<sup>2</sup>*China*

## 1. Introduction

Significant survival of cryopreserved cells became a reality only after the discovery and the use of cell-membrane-permeating cryoprotective agents (CPAs) (e.g. glycerol, Polge et al, 1949). Before freezing, one or various CPAs should be added to cell suspensions to prevent the cells from the cryoinjury during the freezing and thawing processes. Unfortunately, the CPAs, themselves, may have chemical toxicity to cells after thawing at room temperatures (Katkov et al, 1998). Therefore, a post-thaw washing of CPAs is required to remove CPAs from cells prior to scientific or medical applications. However, the addition of CPAs to cells before freezing and the removal of CPAs from cells after thawing may cause serious cell loss and damage if the processes are not properly handled.

“One-step” methods were formerly used for addition/removal CPAs. During the “one-step” CPA addition process, cells are directly (one-step) placed in a solution that is hyperosmotic with respect to the permeating CPA but isosmotic with respect to the impermeable salts/electrolytes. Cells first shrink because of the osmotic efflux of intracellular water and then increase in volume as the CPA permeates and as water concomitantly reenters the cells (as shown in Figure 1a). During the “one-step” CPA removal process, cells with a high intracellular concentration of CPA are directly exposed to an isotonic salt solution without CPA. Cells will swell because of an osmotic influx of extracellular water and then decrease in volume as the CPA diffuses out of the cells and as water concomitantly moves out (as shown in Figure 1b). As a result of these two aspects (i.e. addition and removal of CPAs) of the cryopreservation procedures, the cells may experience severe osmotic volume excursion causing significant cell “osmotic” injury (Sherman, 1973; Mazur and Schneider, 1984, 1986; Penninckx et al, 1984; Leibo, 1986, Crister et al, 1988a, Meryman, 2007).

Several possible reasons for the osmotic injury have been proposed, including (i) rupture of the cell membrane in hypo-osmotic conditions (i.e. expansion lysis); (ii) the water flux hypothesis: frictional force between water and potential membrane ‘pores’ caused cell membrane damage (Muldrew and McGann, 1994); (iii) the minimum volume hypothesis:

cell shrinkage in hyper-osmotic condition is resisted by cytoskeleton components, and the resultant interaction between shrunken cell membrane and the cytoskeleton damages the cells (Meryman, 1970); (iv) the maximum cell surface hypothesis: the cell shrinkage induces irreversible membrane fusion/change, and hence the effective area of cell membrane is reduced; when returned to isotonic condition, the cells lyse before their normal volume is recovered (Steponkus and Wiest, 1979); and (v) the solute loading hypothesis: hyperosmotic stress causes a net leak/influx of non-permeating solutes; when cells are returned to isotonic conditions, they swell beyond their normal isotonic volume and lyse (Mazur et al., 1972).

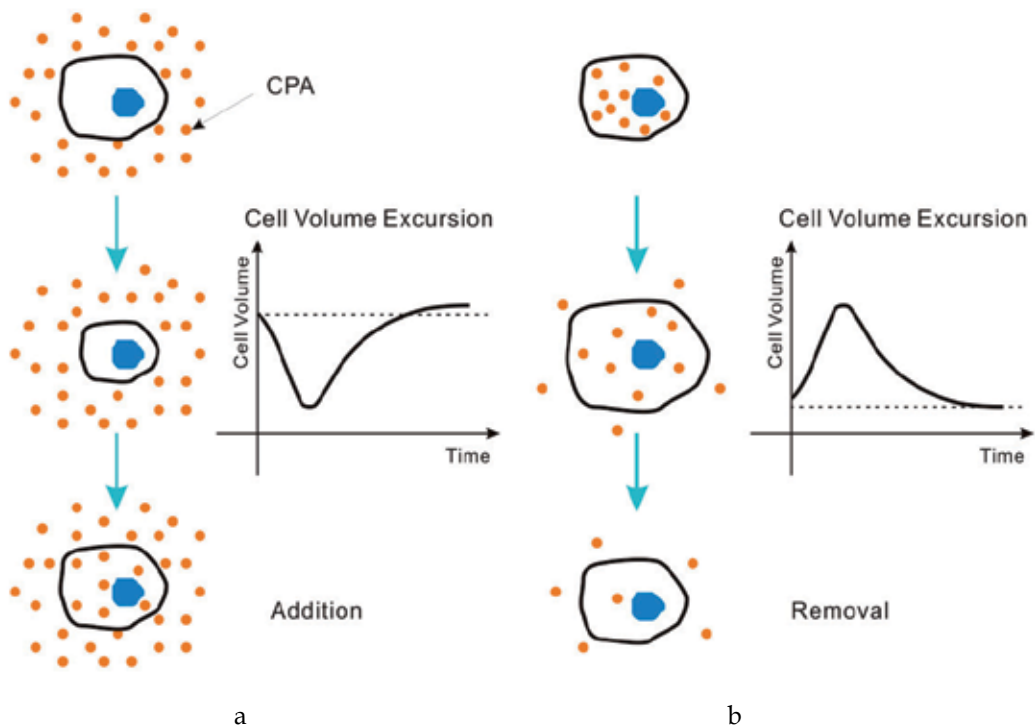

Fig. 1. Cell volume excursion during addition and removal of CPAs

In order to minimize osmotic injury, many efforts have been made and several techniques have been proposed. Basically, people utilize so-called "multi-step methods" instead of "one-step method" for addition and removal of CPAs, and the resulting cell recovery rate can be significantly improved. During the multi-step CPA addition process, solution with high CPA concentration is added into a cell suspension step by step and the CPA concentration in the cell suspension increases slowly and gradually. During the multi-step CPA removal process, an isotonic salt solution is added into the cell suspension step by step, and then by means of centrifugation CPAs in the cell suspension are removed (Figure 2). Although to some extent multi-step method reduces osmotic damage of cells, it is complex to operate, requires more laboratory staffs, and costs more time, which makes the addition and removal procedures more expensive and difficult practically.

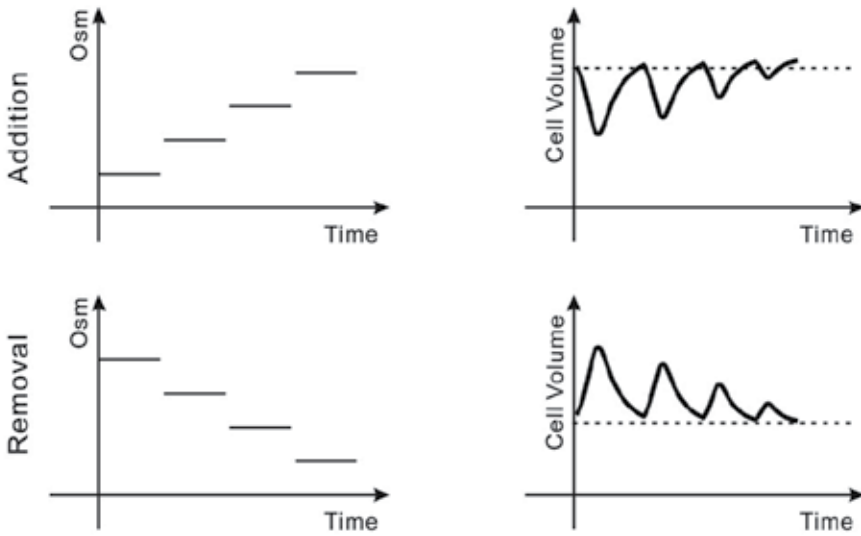

Fig. 2. Multi-step method for addition and removal of a CPA

In the past, attempts to develop procedures for the addition and removal of CPAs have been made based primarily on empirical approaches, i.e. for a given cell type, various temperatures, CPA types and concentrations, and number of procedures or steps for CPA addition and removal were empirically tested to find an acceptable procedure. Typical techniques includes (i) a multi-step addition and multi-step removal of permeating CPAs (Watson, 1979) and (ii) a multi-step addition and two-step removal (using a non-permeating solute as osmotic buffer) of CPAs (Rowe et al., 1968; Mazur and Leibo, 1977; Leibo 1981). New CPA addition-removal methods and automated devices have recently been developed based on fundamental cell membrane transport theory and engineering approaches (Gao, et al, 1995; Gilmore et al, 1997; Katkov, 1998; Myrthe, et al ,2004, Zhou, et al, 2011), which are introduced and discussed in this chapter.

## 2. Cell membrane transport models and mathematical formulatins

To date, a number of formalisms exist for describing the cell membrane transport process. These include a one-parameter model, a two-parameter model, and a three-parameter model, considering solute-solvent interactions.

- i. one-parameter model (Mazur et al, 1974, 1976),

The one-parameter model utilizes the hydraulic permeability ( $L_p$ ) of cell membrane as the only parameter to describe the water transport across cell membrane. The model can be formulized as follows.

$$\frac{dV_w^i}{dt} = -L_p A_c (\Pi_e - \Pi_i) \quad (1)$$

where,  $V_w^i$  is the volume of intracellular water,  $A_c$  is the area of cell membrane surface,  $\Pi_e$  and  $\Pi_i$  are the extracellular and intracellular osmotic pressures.

### ii. Two-parameter model

The two-parameter model was firstly presented by Jacob (1932-1933), and further developed by Kleinhans (1998), Katkov (2000) recently. The model utilizes the parameters  $L_p$  and  $P_s$  (CPA solute permeability) to characterize membrane permeability when water, a permeable solute and a nonpermeable solute are present:

$$\frac{dV_w^i}{dt} = -L_p A_c RT (M^e - M^i) \quad (2)$$

$$\frac{dN_s^i}{dt} = P_s A_c (M_s^e - M_s^i) \quad (3)$$

where  $N_s$  is the number of osmoles of solute inside cell,  $R$  is the universal gas constant,  $T$  is the absolute temperature,  $M_i$  and  $M_e$  are the intracellular and extracellular osmolality, respectively. The subscript 's' refers to permeable solute, and remaining symbols are as previously defined.

### iii. Three-parameter model

The classical formulation of coupled, passive membrane transport was developed by Kedem and Katchalshy (1958) using the theory of linear irreversible thermodynamics. The formulation includes two coupled first-order non-linear ordinary equations which describe the total transmembrane volume flux and the transmembrane permeable solute flux respectively.

In the model (so called Kedem-Katchalssky transport formalism or KK formalism), a reflection coefficient ( $\sigma$ ) was introduced with  $L_p$  and  $P_s$  to describe water and solute (CPA) transport across the plasma membrane:

$$\frac{dV_c}{dt} = -L_p A_c RT \left[ (M_n^e - M_n^i) + \sigma (M_s^e - M_s^i) \right] \quad (4)$$

$$\frac{dN_s^i}{dt} = (1 - \sigma) \bar{M}_s \frac{dV_c}{dt} + P_s A_c (M_s^e - M_s^i) \quad (5)$$

Where  $V_c$  is cell volume,  $\bar{M}_s$  is the average osmolality of intracellular and extracellular solution, and the subscript 'n' refers to nonpermeable solute, respectively.

The KK formalism used to be the most general of the three mentioned. However, more recent literature suggests that aquaporins in cell membrane are highly selective, with nonionic solute transport occurring mainly through the lipid bilayer or through other channels that are distinct from the aquaporins (Gilmore et al, 1995; Preston et al, 1992). In this case, the estimation of  $\sigma$  as independent parameter may be inappropriate and may not be relevant from a biological stand point (Kleinhans, 1998). By assuming that there is no interaction between water and solute during their transport through the membrane, the value of  $\sigma$  can be determined as  $1 - (P_s \bar{V}_s) / (RT L_p)$ , where  $\bar{V}_s$  = partial molar volume of permeating solute. In this manner, the KK formalism can still get correct result as two parameter model.

In the following context, two examples are demonstrated to show how to use cell membrane transport models and mathematical formulations to develop optimal conditions and technology/instrument for the addition and/or removal of the permeating CPAs in cells. **An important hypothesis** is that the degree of cell volume excursion can be used as an independent indicator to evaluate and predict the possible osmotic injury of the cells during addition and removal of CPAs.

Example 1: Development of optimal “multi-step methods” for addition and dilution of glycerol in human sperm

Glycerol is the most commonly used CPA in the cryopreservation of spermatozoa (Polge et al, 1949; Watson, 1979; Critser et al., 1988a). Glycerol permeability characteristics for human spermatozoa have been very well studied and reported (Du et al, 1994; Gao et al., 1992). The hypothesis above was tested first using the following procedures: (i) to determine sperm osmotic injury as a function of its volume excursion limits (swelling/shrinking) in anisotonic solutions containing only non-permeating solutes without glycerol; (ii) to simulate, by computer, the kinetics of water-glycerol transport through the sperm plasma membrane and to calculate the sperm volume excursion during different glycerol addition and removal processes using membrane transport equations and previously determined sperm membrane permeability coefficients for glycerol and water; (iii) combining information obtained from procedures (i) and (ii), to predict sperm osmotic injury caused by different procedures of glycerol addition and removal; and (iv) to perform experiments to test the predictions. If the hypothesis is confirmed, the above procedures also provide a methodology for predicting optimal protocols to reduce the osmotic injury associated with the addition and removal of high concentrations of glycerol in human spermatozoa.

## 2.1 Materials and methods

### Preparation of sperm suspension

Human semen samples were obtained by masturbation from healthy donors after at least 2 days of sexual abstinence. Samples were allowed to liquefy in an incubator (5% CO<sub>2</sub>, 95% air, 37°C, and high humidity) for ~1h. A total of 5 ul of the liquefied semen were used for a computer-assisted semen analysis (CASA) using CellSoft (Version 3.2/C, CRYO Resources, Ltd, Montgomery, NY, USA) (Jequier and Crich, 1986; Crister et al., 1988b). A swim-up procedure was performed to separate motile from immotile cells [layering 500ul of modified Tyrode's medium (TALP: Bavister et al., 1983) over 250 ul of semen, incubating for ~1 h in the incubator and carefully aspirating 400 ul of the supernatant in which >95% of spermatozoa were motile]. The motile cell suspensions were centrifuged at 400g for 7min and resuspended in the TALP medium (286~290 Osmol) supplemented with pyruvate (0.01 mg/ml) and bovine serum albumin (4 mg/ml), at a cell concentration of 1×10<sup>9</sup> cell/ml.

### Assessment of human sperm membrane integrity

A methodology for the assessment of sperm membrane integrity, using dual fluorescent staining and flow cytometric analysis, has been developed by Garner et al. (1986) and previously validated in our laboratory (Gao et al., 1992, 1993; Noilles et al., 1993). Propidium iodide (catalogue no. P4170; Sigma Chemical Co., St Louis MO, USA) is a bright red, nucleic acid-specific fluorophore which permeates poorly into spermatozoa with intact plasma

membrane, but is able to diffuse readily in to spermatozoa with a damaged membrane. 6-Carboxyfluorescein diacetate (CFDA; Sigma, Catalog #C5041) is a membrane-permeable compound. After penetrating into cells, it is hydrolysed by intracellular esterase to 6-carboxyfluorescein which is a bright green, membrane-impermeable fluorophore (Garner et al., 1986). When CFDA is added into the cell suspension with membrane-intact spermatozoa, the cells fluoresce bright green (Garner et al., 1986). Thus 5  $\mu$ l CFDA (0.25 mg/ml DMSO) and 5  $\mu$ l propidium iodide (1 mg/ml water) stock solutions were added to each 0.5ml of the treated sperm suspensions. A total of  $1 \times 10^5$  spermatozoa per treatment were analyzed using a FACStar Plus Flow cytometer (Becton Dickinson, Rutherford, NJ, USA). The cells with CFDA staining and without propidium iodide staining were considered as intact cells. The percentage of intact cells was determined for each treatment.

The flow cytometer settings used for the experiments were (i) the gates were set using forward and  $90^\circ$  light scatter signals at acquisition to exclude debris and aggregates; (ii) instrument alignment was performed daily with fluorescent microbead standards to standardize sensitivity and setup; (iii) photomultiplier settings were adjusted with unstained overlap with individually stained cells; (iv) excitation was at 488 nm from a 4 W argon laser operating at 200 mW. Fluorescein emission intensity was measured using a 530/30 nm bandpass filter, and propidium iodide intensity using a 630/22 nm bandpass filter.

#### **Determination of osmotic injury as a function of sperm volume excursion in anisotonic solutions of nonpermeating solutes**

The anisotonic solutions, ranging from 40 to 1500 mOsmol, were prepared as follows: hypo-osmotic solutions were made osmotic solutions were made by adding sucrose to TALP medium (sucrose and the solutes in TALP medium are essentially membrane-impermeable compounds). The final osmolality of each solution was measured and checked using a freezing-point depression osmometer (Advanced DigiMate Osmometer, Model 3D2; Advanced Instrument, Inc., Needham Heights, MA, USA). The osmotic tolerance of human spermatozoa was evaluated by exposing the cells to the anisotonic solutions. A 10  $\mu$ l volume of isotonic cell suspension (286 mOsmol,  $1 \times 10^9$  cells/ml) was mixed with 150  $\mu$ l of each anisotonic solution. After 1 s to 30 min, spermatozoa in each anisotonic solution were returned to near isotonic conditions (272-343 mOsmol) by adding 1500  $\mu$ l isotonic TALP medium to 100  $\mu$ l of each anisotonic cell suspension. Sperm motility and plasma membrane integrity were measured by CASA and CFDA-propidium iodide dual fluorescent staining techniques respectively before and after the anisotonic exposure. The centrifugal force used in sample preparation was 400 g for 7 min. All experiments were conducted at 22°C.

#### **Thermodynamic modeling and mathematical formulation for glycerol and water permeating across the human sperm membrane**

The next step was to compute the osmotic cell volume excursions associated with the addition and removal of hyperosmotic solutions of the permeating cryoprotectant glycerol to suspensions of human spermatozoa in isotonic saline. The classical KK formalism (shown as equations (4) and (5)) is used here and for the case of a solution consisting of a single permeable solute (e.g. glycerol) the average of extracellular and intracellular cryoprotective agent concentrations (osmolality) can be given as

$$\bar{M}_s = (M_s^e - M_s^i) / \left[ \ln(M_s^e / M_s^i) \right]$$

Since human spermatozoa behave as ideal osmometer (Du et al., 1993), intracellular concentrations of impermeable solute (salt) and permeable solute (cryoprotective agent) can be calculated as previously described (Mazur and Schneider, 1984).

$$M_n^i(t) = M_n^i(0) \left( \frac{V(0) - V_b - \bar{V}_s N_s^i(0)}{V(t) - V_b - \bar{V}_s N_s^i(t)} \right) \quad (6)$$

$$M_s^i(t) = \left( \frac{N_s^i(t)}{V(t) - V_b - \bar{V}_s N_s^i(t)} \right) \quad (7)$$

Where  $V_b$  = osmotically inactive cell volume ( $\mu\text{m}^3$ ), and 0 = initial condition ( $t=0$ ). Initial conditions for  $V(0)$ ,  $M_n^i(0)$ ,  $M_s^i(0)$ ,  $N_s^i(0)$  are known based on each experimental condition or protocol. In the computer simulations, it was assumed that extracellular concentrations of permeating or non-permeating solutes were constant, and that the mixture of solutions during the glycerol addition and removal was instantaneous, i.e. the mixing time = 0.

Human sperm volume, surface area,  $v_b$ , water and glycerol permeability coefficients have been determined and previously published (Gao et al., 1992; Kleinhans et al., 1992; Noiles et al., 1993; Du et al., 1994). The values of these parameters are shown in Table 1. Assuming that there is no interaction between water and glycerol during their transport through the sperm membrane (or in other words, water and glycerol penetrate the cell membrane independently), the value of  $\sigma = 1 - (P_s \bar{V}_s) / (RTL_p)$  (Kedem and Katchalsky, 1958), can be calculated. From this equation and the data in Table 1,  $\sigma$  was calculated to be 0.99. This value was used in the present example.

<b>Surface area</b>	(A)	120 $\mu\text{m}^2$	Kleinhans et al (1992)
<b>Volume</b>	(V)	34 $\mu\text{m}^3$	(Kleinhans et al. (1992)
<b>Osmotically inactive volume</b>	( $V_b$ )	16.6 $\mu\text{m}^3$	Kleinhans et al. (1992) Du et al. (1993)
<b>Water permeability coefficient</b>	( $L_p$ )	2.4 $\mu\text{m}/\text{min}/\text{atm}$	Noiles et al. (1993)
<b>Glycerol permeability coefficient</b>	( $P_s$ )	1.68 $\times 10^{-3}\text{cm}/\text{min}$	Gao et al. (1993)

Table 1. Characteristic of human spermatozoa at 22°C

Using equations [4-7] kinetics of glycerol/water transport across the sperm plasma membrane as well as the cell volume excursion during different glycerol addition and removal procedures were calculated using a commercial differential equation solver, SLAB (Civilized Software, Inc., Bethesda, MD, USA). The sperm volume excursion and water transport through the membrane of cells in anisotonic solution without glycerol were calculated using equation [4] and [5] with  $M_s=0$  and  $N_s=0$ .

### Addition of glycerol

A final 1.00 M glycerol in sperm suspension was achieved by 1:1 (v/v) mixing of the original, isotonic sperm suspension with 2.0M glycerol solution which contains an isotonic

(non-permeating solute) salt concentration. Two approaches for mixing the 2.0 M glycerol solution with the sperm suspension were used, i.e. a fixed-volume-step (FVS) approach and a fixed-molarity-step (FMS) approach:

*Approach 1: fixed-volume-step addition*

A 2.0 M glycerol solution was added stepwise to the sperm suspension, and the volume of the 2.0 M glycerol solution added in each step was constant. For example, to make a four step addition of 1ml of 2.0 M glycerol solution to a 1 ml isotonic sperm sample, 0.25 ml of 2.0 M glycerol solution would be added four times to the isotonic sperm suspension. The time interval between any two steps was 0.5-1 min.

In the general case, the volume of cryoprotective agent stock medium added to cell suspension in each step can be calculated by the following equation:

$$V_i = \frac{M_f \times V_o}{M_o - M_f} \times \frac{1}{n} \quad (8)$$

Where  $M_f$ = the final CPA concentration (molarity) in the cell suspension,  $M_o$  = cryoprotective agent concentration (molarity) in the original stock cryoprotective agent medium,  $n$ = total number of steps,  $i$ = $i^{\text{th}}$  step addition,  $V_o$ = the original volume of isotonic cell suspension, and  $V_i$ = the volume of CPA stock medium added into cell suspension at the  $i^{\text{th}}$  step.

*Approach 2: fixed-molarity-step addition*

Glycerol-containing medium was added stepwise into the cell suspension in such a way that the glycerol molar concentration in the cell suspension was increased by a fixed amount after each step of addition. For example, to increase the molarity by 0.25 M in each of four steps, 0.14, 0.19, 0.27 and 0.4 ml of 2.0 M glycerol stock solution should be added (step by step, four steps in total) to 1 ml of the sperm suspension. The time interval between any two steps was 0.5-1min.

In the general case, the volume of cryoprotective agent stock medium added to cell suspension at the  $i^{\text{th}}$  step can be calculated by the following equation:

$$V_i = \frac{M_f \times V_o \times n \times M_o}{(nM_o - iM_f)[nM_o - (i-1)M_f]} \quad \text{where } i=1, \dots, n \quad (9)$$

$$V_i = \frac{1}{\lambda n (V_o/V_{i-1}^*) - 1} \times V_{i-1}^* \quad (10)$$

$$V_{i-1}^* = V_o + \sum V_k \quad \text{where } k=1, \dots, i-1 \quad (11)$$

$$\lambda = \frac{M_o}{M_f} \quad (12)$$



$$\Delta M = \frac{M_f}{n} \quad (13)$$

Where  $M_f$  = the final cryoprotective agent concentration in the cell suspension (molarity),  $M_o$  = cryoprotective agent concentration in the original stock cryoprotective agent medium (molarity),  $n$  = total number of steps,  $i$  =  $i^{\text{th}}$ -step addition,  $V_o$  = the original volume of isotonic cell suspension (ml),  $\Delta M$  = increment of glycerol molarity in cell suspension after each step of glycerol addition,  $V_{i-1}^*$  = the total volume of cell suspension before the  $i^{\text{th}}$ -step addition,  $V_i$  = volume of cryoprotective agent stock medium added to cell suspension at the  $i^{\text{th}}$  step.

### Removal of glycerol

To dilute the concentrated glycerol in the sperm suspension and remove glycerol from the cells, an isotonic without glycerol was added stepwise to the suspension. The FVS approach, FMS approach, and a two-step osmotic buffer approach were used for the dilution.

#### Approach 1: FVS dilution

Given the volume of the sperm suspension ( $V_o$ ) with an initial cryoprotective agent concentration ( $M_o$ ), the total volume of isotonic solution required to dilute the cryoprotective agent concentration from  $M_o$  to  $M_s$  can be calculated by the following equation:

$$V = \left[ \frac{M_o}{M_s} - 1 \right] \quad (14)$$

Using the FVS approach, the volume of isotonic solution which needs to be added to be cell suspension at the  $i^{\text{th}}$ -step during the first  $n-1$  steps ( $n$  steps in total) can be calculated as follows:

$$V_i = \frac{V}{n-1} = \frac{V_o}{n-1} \left[ \frac{M_o}{M_s} - 1 \right] \quad (15)$$

where  $M_s$  = cryoprotective agent concentration in the cell suspension (molarity) after  $n-1$  step dilutions,  $M_o$  = cryoprotective agent concentration initial sperm suspension (molarity),  $n$  = total number of steps,  $i$  = the  $i^{\text{th}}$ -step addition,  $V_o$  = original volume of cell suspension (ml) and  $V_i$  = volume of isotonic solution added into cell suspension at the  $i^{\text{th}}$  step. After  $n-1$  steps of addition of isotonic solution into the cell suspension, the diluted sperm suspension was centrifuged (400 g for 5-7 min), and then the sperm pellet was resuspended in an isotonic solution, which results in the last ( $n^{\text{th}}$ ) step removal of glycerol from the cells.

#### Approach 2: FMS dilution

Concentrated glycerol in the sperm suspension was diluted stepwise by addition of an isotonic solution. The decrement in the molarity of glycerol after each step dilution was fixed. In the general case, the following equation can be used to calculate the volume of isotonic solution added to cell suspension at the  $i^{\text{th}}$  step during the first  $n-1$  step ( $n$  steps in total):

$$\Delta M = \frac{M_o}{n} \quad (16)$$

$$V_i = \frac{1}{n(V_o/V_{i-1}^*) - 1} \times V_{i-1}^* \quad \text{where } i=1, \dots, n-1 \quad (17)$$

$$V_{i-1}^* = V_o + \sum V_k \quad \text{where } k=1, \dots, i-1 \quad (18)$$

where  $\Delta M$  = the decrement in the glycerol molarity in the spermatozoa after each stepwise addition of the isotonic solution,  $M_o$  = cryoprotective agent concentration (molarity) in the initial sperm suspension,  $n$  = total number of steps,  $i$  =  $i^{\text{th}}$ -step addition,  $V_o$  = original volume of cell suspension,  $V_{i-1}^*$  = the total volume of cell suspension before the  $i^{\text{th}}$ -step addition and  $V_i$  = volume of isotonic solution added into cell suspension at  $i^{\text{th}}$  step. After  $n-1$  step of addition, the cryoprotective agent concentration in the cell was diluted to  $\Delta M$ . Then spermatozoa were transferred to isotonic conditions, which is the last (the  $n^{\text{th}}$ ) step removal of glycerol, see Table 2 for examples.

*Approach 3: Two-step dilution with an osmotic buffer*

Eight-step dilution	
Fixed-volume-step method	Fixed-molarity-step method
Add 100 $\mu\text{l}$ of isotonic TALP seven times to 100 $\mu\text{l}$ of sperm suspension to achieve a final glycerol concentration of 0.125 M. After centrifugation, 710 $\mu\text{l}$ of supernatant is taken off. The remaining cell suspension is 90 $\mu\text{l}$	(1) Stepwise add 14.3, 19, 26.6 and 40 $\mu\text{l}$ of isotonic TALP medium to 100 $\mu\text{l}$ of sperm suspension with 1.0 M glycerol; (2) centrifuge the supernatant; stepwise volume add 10, 20 and 60 $\mu\text{l}$ of isotonic solution to the remaining 30 $\mu\text{l}$ of sperm suspension. After the seven dilution steps, the glycerol concentration in the sperm suspension is 0.125 M. The final suspension volume is 120 $\mu\text{l}$ .
The final sperm suspensions (90 or 120 $\mu\text{l}$ ) were further diluted by adding 180 $\mu\text{l}$ of TALP solution. The time interval between any two steps was $\sim 0.5$ -1 min. The volume of diluent added in each step was calculated using equation [8] or [9]	
One-step dilution	
Add 2000 $\mu\text{l}$ of isotonic solution directly to 100 $\mu\text{l}$ of cell suspension with 1.0 M glycerol	

Table 2. Procedures used in one-step and eight-step removal of 1.0 M glycerol from human spermatozoa

1.	Add 2000 $\mu\text{l}$ of sucrose buffer medium (TALP + sucrose, 600 mOsm to 100 $\mu\text{l}$ of sperm suspension with 1.0 M glycerol. (The total length of time spermatozoa were in contact with sucrose was 0.5 min before centrifugation. Centrifuge the suspension (400 g for 7 min) and aspirate the supernatant. Resuspend the cell pellet with 500 $\mu\text{l}$ of isotonic TALP medium
----	--

Table 3. Procedures used in the two-step removal of 1.0 M glycerol from spermatozoa using sucrose as an osmotic buffer

In the first step, glycerol was directly removed by transferring cells to a hyperosmotic medium (osmotic buffer, TALP with sucrose) containing no glycerol but only non-permeating solutes (salts and sucrose), and in the second step spermatozoa in the osmotic

buffer were directly transferred to an isotonic solution (TALP), (Table 3) (Rowe et al, 1968; Mazur and Leibo, 1977; Leibo, 1981).

### **Experimental examination of the predicted osmotic injury during addition/removal of glycerol**

Medium (TALP) with 2.0M glycerol was added either in one step or stepwise (using FVS or FMS approaches) to an equal volume of the isotonic sperm suspension to achieve a final 1.0 M glycerol concentration at 22°C. The glycerol in the spermatozoa was removed/diluted by a one-step or stepwise addition (using FVS or FMS approaches) of TALP medium, with or without an osmotic buffer (sucrose), to the cell suspension. Some detailed procedures for the removal of glycerol are described in Table 2 and 3. Sperm motility and plasma membrane integrity were measured before and after the different glycerol addition and removal procedures by CASA and the dual staining technique and flow cytometry respectively.

### **Statistical analysis**

Data were analyzed using standard analysis of variance approaches with the General Linear Models procedure of the Statistical Analysis System (Spector et al., 1985). Comparisons were conducted using a protected LSD (least significant difference) approach (Zar, 1984).

## **2.2 Result**

The percentage of spermatozoa which maintained motility or plasma membrane integrity after each treatment was normalized to that of untreated, isotonic control samples and the data are so presented.

### **Determination of osmotic injury as a function of sperm volume excursion**

Human spermatozoa were exposed for 5min to hyper- or hypo-osmotic solutions of sucrose and TALP salts ranging in concentration from 60 to 1200 mOsmol, and their motilities were then determined by CASA while still in those solutions. Figure 3 shows that sperm motilities dropped significantly when the osmolality was >50 mOsmol above or below isotonic (286 mOsmol). Motilities approached zero when the osmolalities were <200 or >600 mOsmol.

The next step was to compare these motilities with those observed after spermatozoa were transferred from these anisotonic solutions back to near isotonic solutions. Figures 4 and 5 show the motilities as a function of time after transfer from hyperosmotic or from hypo-osmotic exposures respectively. In both cases, the more the initial exposure departed from isotonicity, the greater the damage upon return to isotonicity. Most, or all, of the damage was evident in the first 30 s after the return, although in the case of transfer from hypertonic solutions to near isotonic, there was a further slight and gradual decline over the ensuing 30 min.

Figure 6 compares sperm motilities after a 5 min exposure to the various anisotonic solutions before and after the return to near isotonic conditions. The reduction in the motilities of spermatozoa exposed to hypo-osmotic media was not affected by the return to isotonic media, but most of the apparent loss of motility of spermatozoa in hyperosmotic media of between 286 and 600 mOsmol was reversed when spermatozoa were returned to near isotonic. For example, although only 10% of spermatozoa were motile in 600 mOsmol

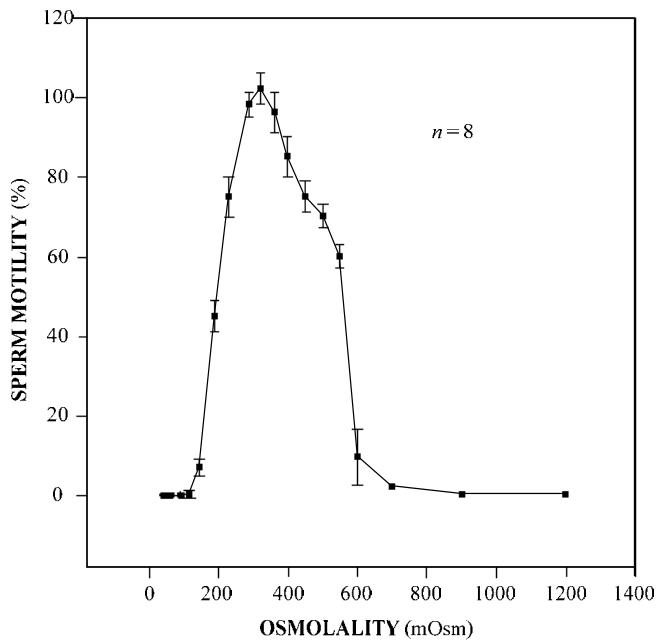

Fig. 3. Percent motility (mean $\pm$ SEM,  $n=8$ ) of human spermatozoa which were abruptly (one-step) exposed to different osmotic conditions for 5 min at 22°C.

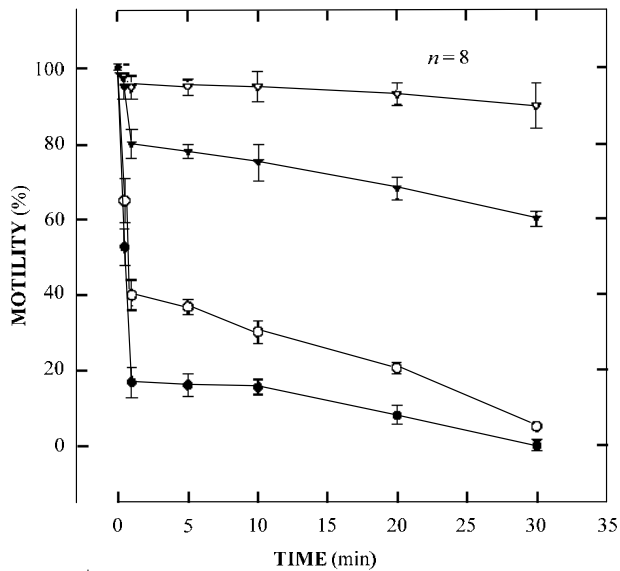

Fig. 4. Percent motility (mean $\pm$ SEM,  $n=8$ ) of human spermatozoa which were abruptly (one-step) returned to near isotonic conditions (305-343 mOsmol) after they had been exposed to different hyperosmotic conditions (TALP +sucrose) for different periods of time.  $\nabla$ , 600 mOsmol;  $\blacktriangledown$ , 700 mOsmol;  $\circ$ , 900 mOsmol;  $\bullet$ , 1200 mOsmol.

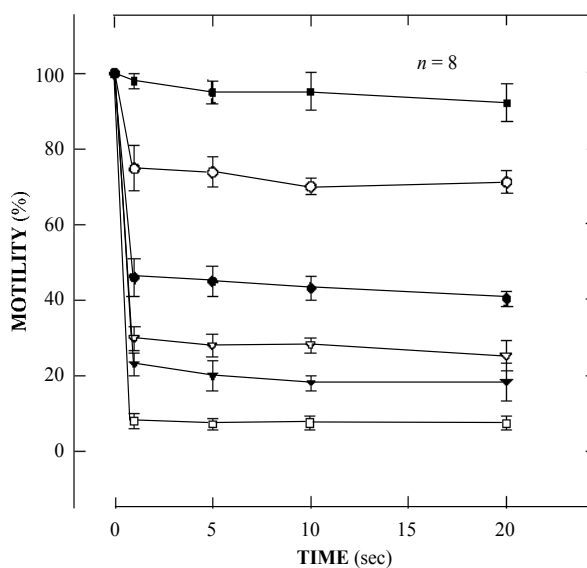

Fig. 5. Percent motility (mean±SEM,  $n=8$ ) of human spermatozoa which were abruptly (one-step) returned to near isotonic conditions (273-284 mOsmol) after they had been exposed to different hyperosmotic conditions (TALP +water) for different periods of time. ■, 240 mOsmol; ○, 215 mOsmol; ●, 190 mOsmol; ▽, 143 mOsmol; ▼, 114 mOsmol; □, 90 mOsmol.

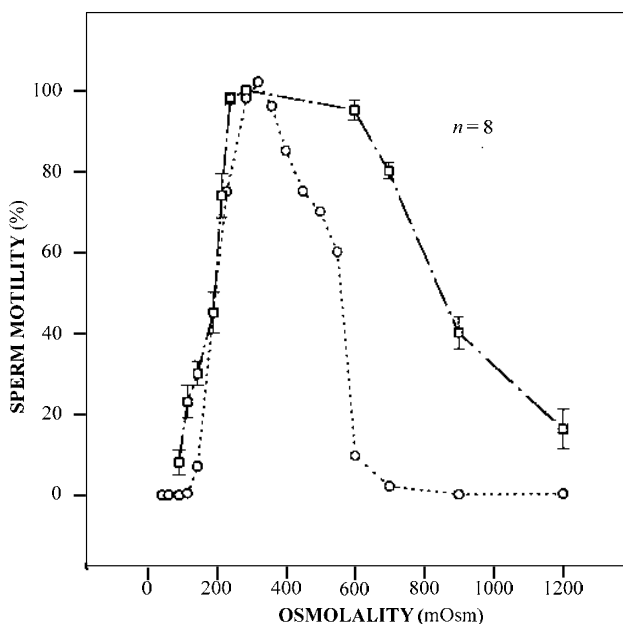

Fig. 6. A comparison of human sperm motility (% mean±SEM,  $n=8$ ) after a 5 min exposure to the various hypo- and hyperosmotic solutions of non-permeating solutions before (○) and after (□) the return to near isotonic conditions (273-343 mOsmol).

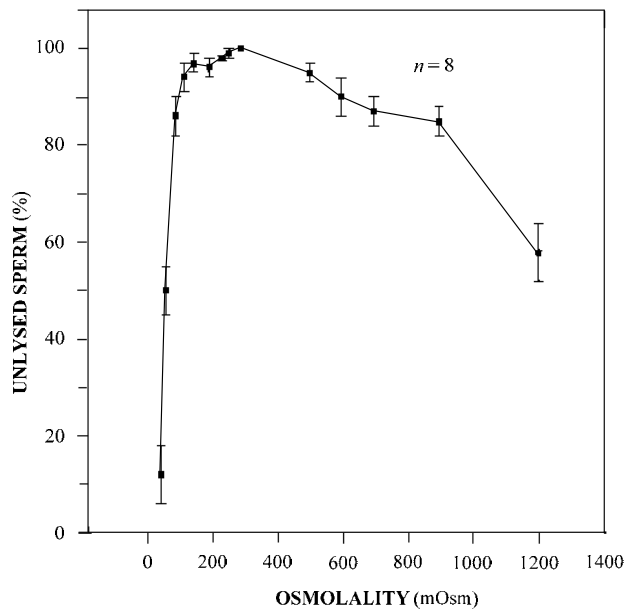

Fig. 7. Membrane integrity (CFDA and propidium iodide stain) (% mean $\pm$ SEM,  $n=8$ ) of human spermatozoa which were abruptly (one-step) returned to near isotonic conditions (273-343 mOsmol) after they had been exposed to different anisosmotic conditions for 5 min.

solutions, 95% of spermatozoa were motile after return to isotonic media. The return to near isotonic became especially damaging, however, when the initial hyperosmotic concentration was >600 mOsmol.

Figure 7 shows that integrity of the plasma membrane of spermatozoa (as assessed by CFDA /propidium iodide) was substantially more resistant to wide excursions from isotonicity than was motility. Thus, >90% of those spermatozoa exposed to a 90 mOsmol salt solution retained intact plasma membrane after return to near isotonic, whereas <10% remained motile both before and after return to isotonic. Loss of plasma membrane integrity in 50% of the spermatozoa occurred only when spermatozoa were exposed to a 60 mOsmol solution, a figure that agrees with a previous report (Noiles et al, 1993); that loss occurs whether or not spermatozoa are returned to isotonic. This has been interpreted to represent lysis from the attainment of a cell volume in excess of that tolerated by the surface area of the plasma membrane.

Using light microscopy, morphological changes in sperm cells were observed during the exposure to anisosmotic solutions. In a portion of the spermatozoa, the tail region became configured as a 'zigzag' pattern when exposed to a hyper-osmotic solution. The pattern of sperm tail curling in hypo-osmotic solutions was osmolality dependent, which is consistent with a previous report (Jeyendran et al., 1984). In addition, the curling of sperm tails occurred not only when the isotonic spermatozoa were exposed to a relative hypo-osmotic condition. (For example, the shrunken spermatozoa in hyperosmotic solutions were returned to iso-osmotic conditions. Iso-osmolality was 'hypo' relative to a given hyper osmolality.) The tail curling was irreversible. The mechanism(s) behind the morphological change is not clearly understood.

### Calculated volume excursions associated with exposures to anisotonic solutions

Since it has been shown that human spermatozoa behave as ideal osmometer over most of the range of osmolalities studied here (Du et al., 1993), a direct physical consequence of the exposures to anisotonic conditions is major excursion in cell volume. The kinetics of volume excursion of spermatozoa in these hypo- and hyperosmotic solutions (containing only non-permeating solutes) were calculated and are plotted in Figure 8A and B

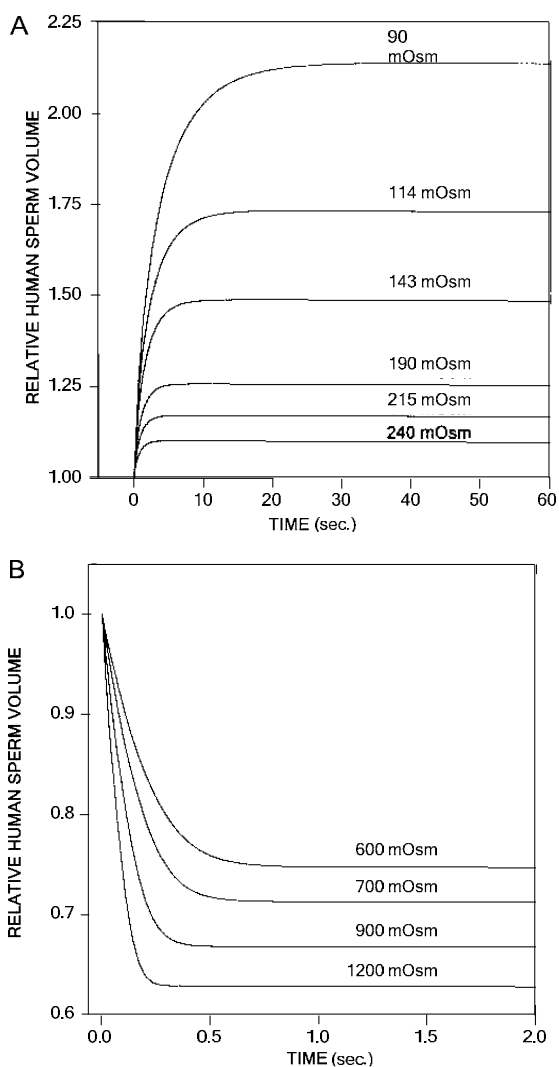

Fig. 8. (A) Calculated relative sperm volume (normalized to an isotonic sperm volume of 1) as a function of time after spermatozoa were one-step exposed to different hypo-osmotic solution containing non-permeating solutes. (B) Calculated relative sperm volume (normalized to the isotonic sperm volume of 1) as a function of time after the isotonic spermatozoa were one-step exposed to different hyperosmotic solutions containing non-permeating solutes.

respectively, indicating that only a short time was required for human spermatozoa to achieve osmotic equilibration ( $<1$  s for shrinking, and  $\leq 30$  s for swelling). Figure 8A and B also show the maximum or minimum volume of spermatozoa when they were osmotically equilibrated with each anisotonic solution. Sperm equilibration volume as a function of extracellular osmolality is shown in Figure 9, which can be calculated using equation (6) (no cryoprotective agent) or obtained directly from Figure 8A and B. To obtain a high ( $>95\%$ ) motility recovery, the lowest and highest osmolalities which human spermatozoa can tolerate (Figures 4 and 5) were found to be close to 240 and 600 mOsmol respectively. At these two osmolalities, the corresponding cell volume at osmotic equilibrium were directly estimated (Figure 9) to be  $\sim 1.1$  (for 240 mOsmol) and 0.75 (for 600 mOsmol) times the isotonic sperm volume, indicating that spermatozoa can only swell or shrink in a relatively narrow range to maintain high post-anisotonic motility recovery. Based on Figure 4, 5 and 9, Figure 10 was plotted, which clearly shows the post-anisotonic injury (motility loss) as a function of osmotic equilibrium volume of spermatozoa in anisotonic solutions. Defining lower volume limit (LVL) and upper volume limit (UVL) as cell volumes at which 5% of motile spermatozoa may irreversibly lose their motility, or, reciprocally, 95% of spermatozoa maintain their motility, one can obtain the LVL and UVL values for human spermatozoa from Figure 10 as follows: LVL =  $0.75 \times$  isotonic sperm volume, UVL =  $1.10 \times$  isotonic sperm volume.

#### Prediction of optimal protocols for glycerol addition/removal

The kinetics of human sperm volume excursion during one-step addition and removal of 0.5-2.0 M glycerol were calculated using equations (6-9) and are shown in Figure 11A and B respectively. The higher the glycerol concentration, the longer the time period taken for sperm volume recovery and the greater the volume excursion.

Two different approaches, i.e. fixed-volume-step (FVS) and fixed-molarity-step (FMS), for the addition/removal of glycerol in spermatozoa were considered and used in the present example. Based equations (6-9), the kinetics of water and glycerol transport through the

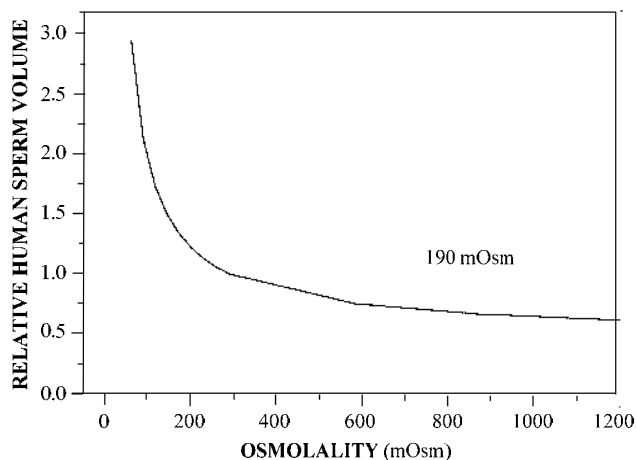

Fig. 9. Calculated relative sperm volume (normalized to the isotonic sperm volume of 1) after spermatozoa were osmotically equilibrated to different anisotonic conditions.



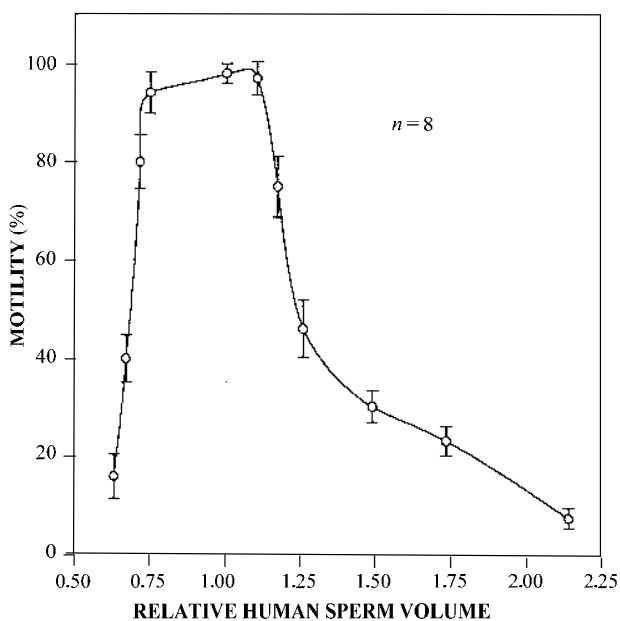

Fig. 10. Post-anisotomic sperm motility recovery as a function of relative sperm volume (normalized to the isotonic sperm volume of 1) in different anisotomic equilibrium states. Human spermatozoa were abruptly (one-step) returned to near isotonic conditions after exposure to anisotomic conditions for 1 min.

sperm membrane were simulated by computer. Figure 12 shows the calculated sperm volume excursion during a one-step or four-step addition of glycerol achieve a final 1.0 M glycerol concentration at 22 C using the FMS and FVS approaches respectively. From Figure 12, a one-step addition of glycerol to spermatozoa was predicted to cause ~20% sperm motility loss because the minimum volume which the cells would achieve during this glycerol addition was ~72% of the original cell volume, i.e. below the LVL (75% or 0.75  $\times$  isotonic sperm volume). In contrast, a four-step FMS glycerol addition was predicted to be able to prevent sperm loss (<5% loss). Figure 12 also shows a comparison between a four-step FVS and FMS approach. A four-step FVS method was predicted to cause a lower minimum volume than a four-step FMS method. From Figure 13, a one-step removal of 1.0 M glycerol was predicted to cause >70% motility loss, because the maximum cell volume during the glycerol removal was calculated to be in excess of 1.6 times the isotonic cell volume, which is much higher than the UVL (1.1 $\times$ isotonic sperm volume). Figure 14 shows that a four- or six-step FMS removal procedure was predicted to reduce sperm motility loss significantly, but these still may cause >5 % motility loss, while an eight-step FMS removal was predicted to able to prevent sperm motility loss (<5% loss). Figure 13 also shows a comparison between an eight-step FMS and an eight-step FVS removal procedure. An eight-step FVS removal was predicted to cause a maximum cell swelling >1.2\* isotonic cell volume (>UVL), while the maximum cell volume during an eight-step FMS removal was predicted to be much lower than the UVL, indicating the eight-step FVS removal is not as good as an eight-step FMS. Based on the data presented in Figures 11-14, it was also found, from calculations, that human spermatozoa will

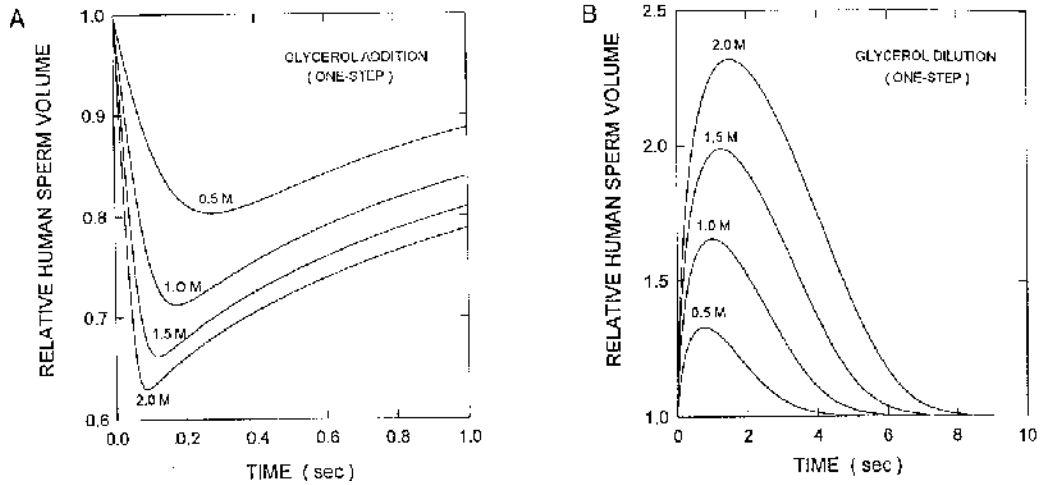

Fig. 11. (A) Calculated relative sperm volume (normalized to the isotonic sperm volume of 1) as a function of time after the isotonic sperm were exposed to different hyperosmotic glycerol solution isotonic with respect to non-permeating solutes (salt). (B) Calculated relative sperm volume (normalized to the isotonic sperm volume of 1) as a function of time after spermatozoa, which had been pre-equilibrated with different hyperosmotic glycerol solutions isotonic with respect to non-permeating solutes (salt), were one-step exposed to isotonic (286 mOsmol) saline solution without glycerol.

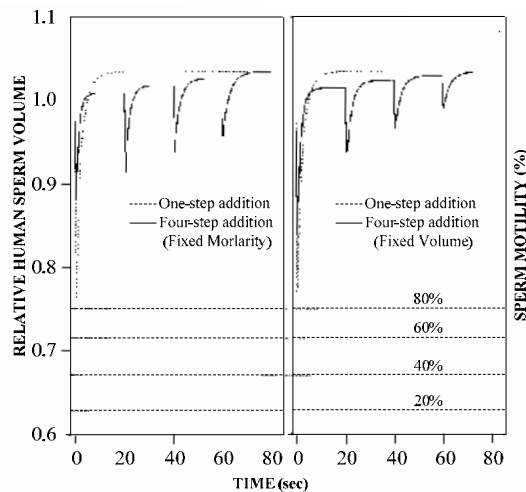

Fig. 12. (left) Calculated relative sperm volume (normalized to the isotonic sperm volume of 1) as a function of time after 1M glycerol was added to spermatozoa by either one-step or four fixed molarity steps. (right) Calculated relative sperm volume (normalized to the isotonic sperm volume of 1) as a function of time 1M glycerol was added to spermatozoa by either one step or four fixed-volume steps. The estimates of percent motility recovery as a function of sperm relative volume were obtained from Figure 8 and are indicated in the diagrams.

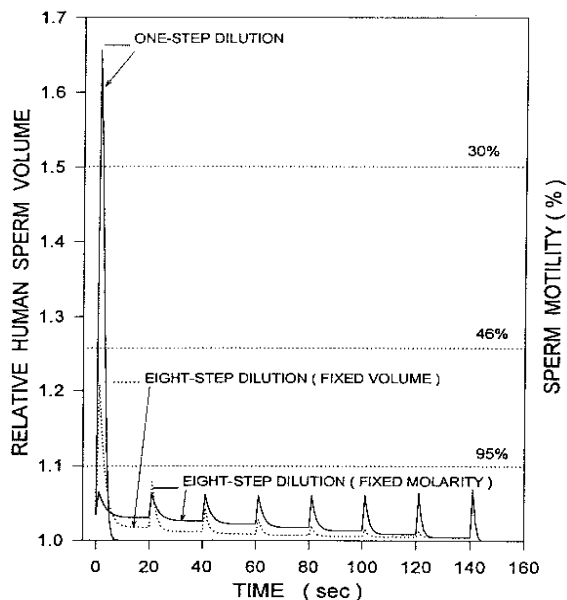

Fig. 13. Calculated relative sperm volume (normalized to the isotonic sperm volume of 1) as a function of time after 1 M glycerol was removed from spermatozoa by one-step, eight fixed-molarity steps or eight fixed-volume steps. The estimates of percent motility recovery as a function of sperm relative volume were obtained from Figure 10 and are indicated in the diagrams.

rapidly achieve an osmotic equilibrium (within 15 s) during any stepwise addition or removal of glycerol. For example, from the calculations, human spermatozoa achieve osmotic equilibrium within 15 s after each step addition of glycerol by either one-step of four-step addition (Figure 12). This indicates that only a short time interval between steps of glycerol addition/removal is required for cells to achieve corresponding osmotic equilibration volume after each step of glycerol addition and removal.

In the analysis above, sperm osmotic injury (motility loss) caused by different glycerol addition/removal procedures has been predicted and a four-step FMS addition and an eight-step FMS removal of 1.0 M glycerol were found to be acceptable protocols to prevent sperm motility loss (<5%).

#### Theoretical evaluation of two-step glycerol removal using an osmotic buffer

A two-step removal of cryoprotective agent from human spermatozoa using a non-permeating solute as an osmotic buffer has been previously used to avoid osmotic injury in other cell types (Rowe et al., 1968; Leibo and Mazur, 1978; Watson, 1979). The steps involved in this approach are (i) the cryoprotective agent is directly removed and cell swelling is reduced by transferring cells with the cryoprotective agent to a hyperosmotic medium (osmotic buffer) of non-permeating solutes; and (ii) the cells in the osmotic buffer are rehydrated by directly transferring them to isotonic solution. Since current results showed that 600 mOsmol was the hyperosmotic upper tolerance limit for human spermatozoa to maintain 95% motility, the osmolality of the osmotic buffer medium should not exceed 600

mOsmol. Using this limiting criterion, a hyperosmolality of 600 mOsmol would be expected to provide the maximum 'buffer effect' to reduce sperm volume swelling during the first step of glycerol removal. Sperm volume excursion during this two-step glycerol removal process was calculated and is shown in Figure 15. It was predicted that the maximum volume spermatozoa would achieve is 1.25 times (15%) the isotonic cell volume, which is higher than the UVL of human spermatozoa, and could be expected to cause >40% sperm motility loss, as predicted from Figure 10.

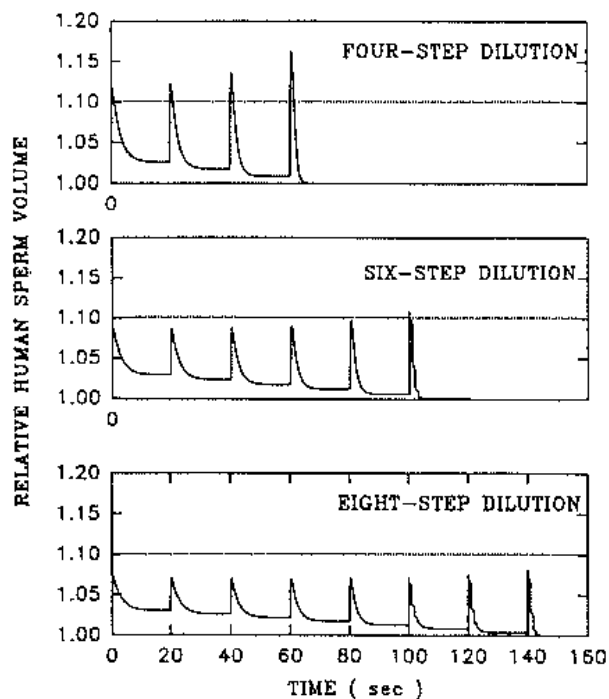

Fig. 14. Calculated relative sperm volume (normalized to the isotonic sperm volume of 1) as a function of time after 1 M glycerol was removed from spermatozoa by four, six and eight fixed-molarity steps. The dotted lines in this figure indicate the upper volume limit, 1.1, below which >95% of spermatozoa can maintain the motility. The four- or six-step dilution results in a cell volume excursion causing >5% motility loss.

### Results from experimental examination

Glycerol was added to or removed from human spermatozoa using stepwise procedure to test the theoretical predictions. A one-step addition resulted in  $\sim 19.2\%$  sperm motility loss or  $81.8 \pm 8.7\%$  ( $\bar{X} \pm \text{SEM}$ ,  $n=15$ ) motility recovery, while the four-step FMS or FVS addition significantly ( $P < 0.001$ ) increased in the motility recovery to  $93.5 \pm 5.6\%$  ( $\bar{X} \pm \text{SEM}$ ,  $n=15$ ) or  $91 \pm 4.8\%$  ( $\bar{X} \pm \text{SEM}$ ,  $n=15$ ) respectively. During different glycerol removal procedures (c.f. Table 2),  $<30\%$  ( $28.5 \pm 3.8\%$ ,  $n=15$ ) of motile spermatozoa kept their motility after a one-step removal of 1.0 M glycerol, while the majority of spermatozoa ( $92 \pm 8.2\%$ ,  $n=15$ ) maintained motility after the eight-step FMS removal. In comparison, only  $62 \pm 5.8\%$  of spermatozoa maintained motility after eight-step FVS removal. The motility recovery after a two-step

removal of glycerol (Table 3) using sucrose as an osmotic buffer was  $43 \pm 5.3\%$  ( $\bar{X} \pm \text{SEM}$ ,  $n=15$ ). The experimental result agreed well with the predictions generated from the computer simulations. Data analyses indicated that the different glycerol removal procedures caused different motility losses ( $P < 0.001$  between any two procedures). Over 90% of spermatozoa maintained membrane integrity under all experimental conditions.

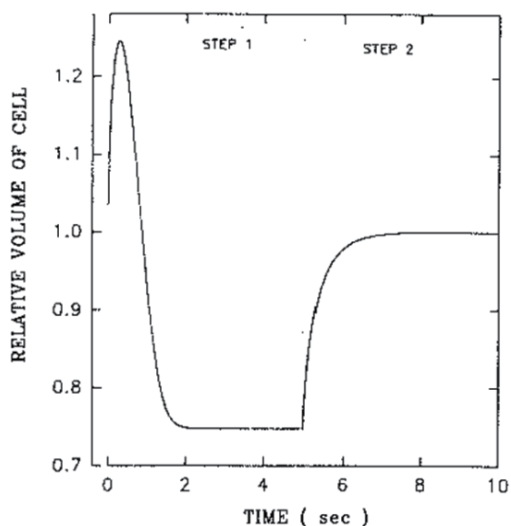

Fig. 15. Calculated relative sperm volume (normalized to the isotonic sperm volume of 1) as a function of time after 1 M glycerol was removed from spermatozoa by two steps using a 'hyperosmotic buffer' solution. Step 1: 1.0 M glycerol was removed from spermatozoa by one -step exposure of spermatozoa to 600 mOsmol hyperosmotic (salt+sucrose) solution without glycerol. Step 2: Spermatozoa in the 600 mOsmol solution were returned to isotonic condition (286 mOsmol) in one step.

Example 2: Development of a novel dilution-filtration method and instrument to remove glycerol from human red blood cells (RBCs)

Cryopreservation has been widely used today around the world for long term preservation of RBCs. In the USA, the FDA has approved the storage of frozen RBCs at  $-80^{\circ}\text{C}$  for as long as 10 years (Meryman, 2007). However, the glycerol in RBCs must be reduced to final concentration below 1% before infusion to prevent hemolysis (Valeri et al, 2001). The step of removing CPAs may cause serious cell loss due to the cell volume excursion induced by osmotic disequilibria (Meryman, 2007). In the past decades, many efforts have been made to improve the process (Rowe et al, 1968; Meryman et al, 1972, 1977; Valeri et al, 1975, 2001; Castino et al, 1996; Arnaud et al 2003).

Currently, multi-step centrifuging methods are most commonly used, and some of them can achieve favorable results (Rowe et al, 1968; Meryman et al, 1972, 1977; Valeri et al, 1975, 2001). However, the procedures are very difficult and time consuming for manual operation due to the large cell suspension volume or high CPA concentration. In addition, most of the systems are not closed and are thus open to contamination (Castino et al, 1996; Valeri et al, 2006). Automatic centrifuging systems may significantly reduce human labor and

contamination (Valeri et al, 2001), but the expensive cost limits their application in many areas. Recently, Dialysis was considered as an alternative method by some researchers (Castino et al,1996; Arnaud et al 2003; Ding et al 2007,2010). It can remove CPAs efficiently; however, due to the non-uniformity of distribution of hollow fibers, the mass transport in dialyzer is too complicated to be controlled, especially in the unsteady state. In addition, dialysis method is not efficient to remove large molecular substances (Daugirdas, et al, 2006), such as cell fragment and the released protein from broken cells. These factors limit the use of dialysis method in some applications.

In clinic, hemofiltration, which involves dilution and filtration to remove toxins from blood, has been proved to have better controllability as well as ability of removing large molecular substances than hemodialysis (Daugirdas, et al, 2006). By referencing to hemofiltration, a dilution-filtration system is developed recently for removing CPAs (Zhou et al, 2011). The closed system helps to avoid contamination to cells, and the continuous and automatic process could provide particular advantage in efficiency especially for large-scale samples. The related research work is introduced in the following.

## 2.3 Materials and methods

### Technical Design

A dilution-filtration system is developed as shown in Fig.16 (Hemofilter: Plasmflo™ AP-05H/L, ASAHI; Pumps: 400F/M1, Watson-Marlow; silicone tubing: 985-75, Pall). For removing CPAs, thawed cell suspension is first transferred into the special blood bag (made by an infusion bag). Then, the suspension is driven by the blood pump to flow circularly among the bag, the mixer and the hemofilter. While going through the mixer, the suspension is quickly diluted by diluent, and the dilution ratio can be controlled to prevent lysis. In the hemofilter, extracellular solution containing CPA is partly ultrafiltrated while cells keep inside. Along with the circulation goes on, CPAs in cell suspension can be removed continuously. The whole process is conducted automatically in a closed system, and thus it is hopeful for this method to reduce human labor as well as the risk of contamination significantly.

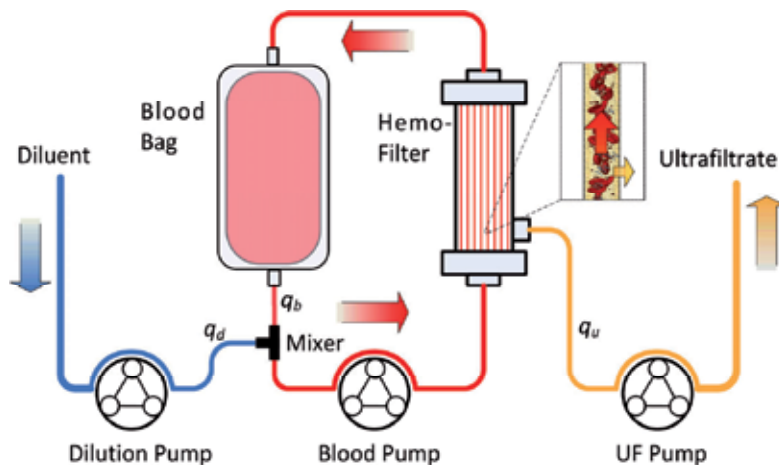

Fig. 16. Principle of the dilution-filtration system. Cell suspension is diluted and ultrafiltrated during circulating in the system, and then the CPAs inside can be continuously removed.

### Theory of optimal operation protocol

Optimal operation protocol is defined here as the processes that minimize the operation time (to a final CPA concentration below 10g/L) as well as the osmotic cell volume excursion. A theoretical model was developed to predict the optimal operation protocols under the given experimental conditions (initial CPA concentration, cell density and total volume of cell suspension) and practical constraints. The detailed considerations for this procedure are described below.

### Basic Assumptions and Formulation

The theoretical model of the dilution-filtration system is developed (as shown in Fig.17) under the following assumptions: (1) Both intra- and extra-cellular solutions in cell suspension consist of water, a permeable CPA (e.g. glycerol) and an impermeable salt (e.g. NaCl); (2) Blood bag, hollow fibers and their connecting tubing are filled with cell suspension, and cells are uniformly distributed in the suspension; (3) Extracellular solution is diluted/filtrated immediately and evenly at the diluting/filtrating point when cell suspension circulates in the system; (4) Suspension flow is one dimensional, and the convection factors can be neglected.

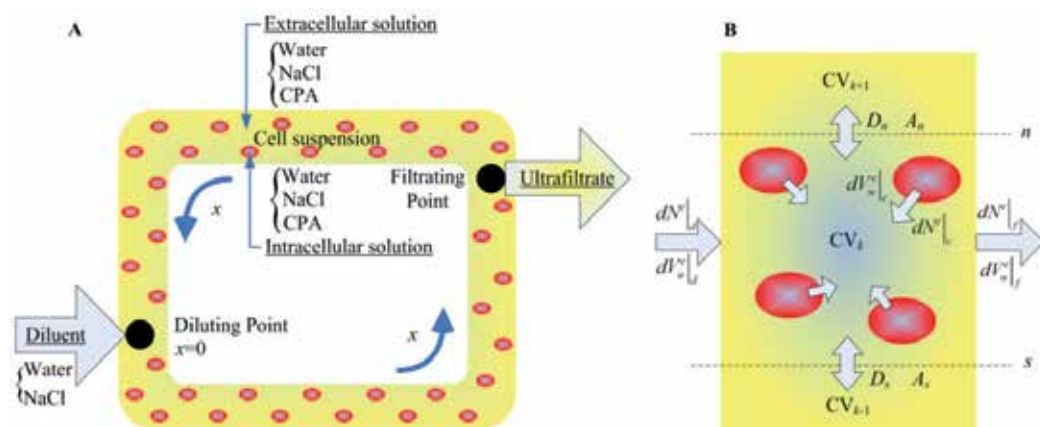

Fig. 17. Theoretical modeling of the system. A: the overall system, and B: a control volume.

Based on the assumptions, a governing equation about the mass transfer process can be derived by focusing on the extracellular solution:

$$\frac{\partial \phi^e}{\partial t} = \frac{1}{A} \frac{\partial}{\partial x} (DA \cdot \frac{\partial \phi^e}{\partial x}) + S \quad (19)$$

where, A refers to effective mass transfer area, D refers to diffusion coefficient,  $\phi^e$  refers to extracellular solute concentration (in osmolality), and S is the mass source/sink term, respectively.

#### Source/Sink terms

The source/sink term can be derived by temporarily ignored the diffusion term:

$$S = \frac{\overline{d\phi^e}}{dt} = \frac{\overline{d(N^e/V_w^e)}}{dt} = \frac{1}{V_w^e} \frac{\overline{dN^e}}{dt} - \frac{\phi^e}{V_w^e} \frac{\overline{dV_w^e}}{dt} \quad (20)$$

where  $N^e$  and  $V_w^e$  are the number of osmoles of solutes and water volume in extracellular solution, respectively. The overlines in the equation indicate the given deriving condition. The terms of  $\overline{dN^e}$  and  $\overline{dV_w^e}$  can be further specified as

$$\overline{dN^e} = dN^e|_d - dN^e|_f + dN^e|_c \quad (21)$$

$$\overline{dV_w^e} = dV_w^e|_d - dV_w^e|_f + dV_w^e|_c \quad (22)$$

where the subscripts "d", "f" and "c" refer to the effects of dilution, filtration and cell membrane transport, respectively. According to assumption (2), cell suspension inside the system can be equally divided into a finite number of control volumes (CVs), as shown in Fig.17B. For each CV, the values of the terms in the right hands of equation [21] and [22] can be determined as flows.

#### i. Dilution/filtration

According to assumption (3), when a CV is going through the diluting point, the extracellular solution will be diluted immediately. Considering the pure filtration method used in the system, it is also assumed that ultrafiltration happens only at a certain location (the filtrating point, shown in Fig.17A), and the ultrafiltrate has the same composition as the extracellular solution. Thus the values of  $dV_w^e|_d$ ,  $dN^e|_d$ ,  $dV_w^e|_f$  and  $dN^e|_f$  of each CV can be determined as

$$\overline{dV_w^e|_d} = \begin{cases} \frac{Q_d V_{CV}}{Q_b} & \text{CV at the diluting point} \\ 0 & \text{CVs at the other locations} \end{cases} \quad (23)$$

$$\overline{dN^e|_d} = \overline{dV_w^e|_d} \cdot \phi^d \quad (24)$$

$$\overline{dV_w^e|_f} = \begin{cases} \frac{Q_f V_{CV}}{(Q_b + Q_d)(1 + \bar{V}_s \phi_s^e)} & \text{CV at the filtrating point} \\ 0 & \text{CVs at the other locations} \end{cases} \quad (25)$$

$$\overline{dN^e|_f} = \overline{dV_w^e|_f} \cdot \phi^e \quad (26)$$

where  $Q_f$ ,  $Q_b$  and  $Q_d$  are the flow rates of ultrafiltrate, cell suspension and diluent,  $\phi^d$  is the solute concentration in diluent,  $\phi_s^e$  is the extracellular CPA concentration,  $\bar{V}_s$  is the partial molar volume of the CPA, and  $V_{CV}$  is the volume of a CV, respectively.



ii. Transportation across cell membrane

For the ternary system as considered in the present example, the mass transport across cell membrane can be described by the two-parameter formalism [2,3]. The total cell volume is the sum of the water, CPA and cell solid volumes:

$$V_c = V_w^i + V_s^i + V_{cb} \quad (27)$$

where the intracellular CPA volume can be determined as  $V_s^i = \bar{V}_s N_s^i$ . As soon as cell volume and intracellular solute concentrations are calculated the values of  $dN_s^e|_c$  and  $dV_w^e|_c$  can be further determined based on mass conservation:

$$dN_s^e|_c = -n_c dN_s^i, \quad dN_n^e|_c = 0 \quad (28)$$

$$dV_w^e|_c = -n_c dV_w^i = -n_c (dV_c - dV_s^i) \quad (29)$$

where  $n_c$  is the number of cells in a CV.

Numerical Simulation

With finite volume method, a fully implicit control volume integration of the governing equation will result in a finite difference scheme:

$$\left[ a_{k-1} + a_{k+1} + a_k^{old} - (S_p V_{CV})_k \right] \phi_k^e = a_{k-1} \phi_{k-1}^e + a_{k+1} \phi_{k+1}^e + a_k^{old} \phi_k^{eold} + (S_c V_{CV})_k, k = 2, \dots, K-1 \quad (30)$$

where  $a$  is the coefficient and  $K$  is the total number of CV in the system. The subscript 'k' refers to the kth CV in the system and the superscript 'old' refers to the previous time level.  $S_c$  and  $S_p$  are the constant portion and gradient of the linearized source term:

$$S_c = \frac{1}{V_w^e} \frac{dN^e}{dt}, \quad S_p = -\frac{1}{V_w^e} \frac{dV_w^e}{dt} \quad (31)$$

The subscript 'k-1' and 'k+1' in equation (30) refer to the previous and next CVs along the  $x$  direction, respectively. Noting that the cell suspension flows circularly in the closed system, the 1st CV is followed by the Kth one. Thus

$$\left[ a_K + a_2 + a_1^{old} - (S_p V_{CV})_1 \right] \phi_1^e = a_K \phi_K^e + a_2 \phi_2^e + a_1^{old} \phi_1^{eold} + (S_c V_{CV})_1 \quad (32)$$

$$\left[ a_{K-1} + a_1 + a_K^{old} - (S_p V_{CV})_K \right] \phi_K^e = a_{K-1} \phi_{K-1}^e + a_1 \phi_1^e + a_K^{old} \phi_K^{eold} + (S_c V_{CV})_K \quad (33)$$

Here, the removal of glycerol from cryopreserved human red blood cells (RBCs) is discussed for an instance. For the ease of discussion, it is further restricted that blood volume keeps constant, i.e. ultrafiltrate flow rate keeps equal to diluent flow rate, although the presented system and model can adapt to more complicated situations. Besides, the concentration of NaCl in diluent and thawed blood are considered to be isotonic (0.29 Osmol/kg water). In

this manner, the basic variables for a simulation consist of the experimental conditions (including the initial blood volume ( $V_b^0$ ), hematocrit ( $h^0$ ), and the concentrations of CPA ( $M_s^0$ ) in extra/intracellular solution) as well as the operation parameters (including the flow rates of blood ( $Q_b$ ) and diluent ( $Q_d$ )). The initial values of the other parameters in the model can be determined as

$$V_{CV}^0 = V_b^0 / K \quad (35)$$

$$V_c^0 = V_{iso} + V_s M_s^0 (V_{iso} - V_{cb}) \quad (36)$$

$$n_c^0 = V_{CV}^0 h^0 / V_c^0 \quad (37)$$

where  $V_{iso}$  is the isotonic volume of RBC. When terming the CV at the diluting point ( $x=0$ ) when  $t=0$  as the 1st CV ( $CV_1$ ), the initial location of each CV can be allocated. Then the values of  $dN^e$  and  $dV^e$  for each CV can be calculated according to equations [21]-[31]. By alternatively calculating the source terms and solving the linearized governing equation, the concentration variation of extra-/intracellular solution as well as the responding cell volume excursion can be simulated. A typical process is shown in Fig.18, in which  $V_b^0 = 200\text{ml}$ ,  $h^0 = 30\%$ ,  $M_s^0 = 6.28 \text{ Osmol/kg water}$  (approximately 40% w/v),  $Q_b=200\text{ml/min}$ , and  $Q_d=25\text{ml/min}$ .

To quantitatively evaluate the effect of an operation protocol, the maximum cell volume and the total time cost (to a final glycerol concentration below 10g/L (Brecher, 2002)) of the removing process can be taken as criteria for cell recovery rate and removing efficiency, respectively. Then the optimal protocol can be found out by applying different operation parameters to the given experimental conditions and comparing the simulated results. Hereinafter, the diffusion coefficients of glycerol and NaCl in water were set to be  $5.43 \times 10^{-10} \text{ m}^2/\text{s}$  and  $14.41 \times 10^{-10} \text{ m}^2/\text{s}$ , respectively (Ternstorm et al, 1996). The parameters about the dilution-filtration system and RBC membrane are also specified as listed in Table 4 and Table 5. These parameters may be different in various applications and systems.

Sections	Inner volume	Effective area
From the outlet of blood bag to the diluting point	5ml	$1.25 \times 10^{-5} \text{ m}^2$
From the diluting point to the filtrating point	5ml	$1.25 \times 10^{-5} \text{ m}^2$
From the filtration point to the outlet of hemofilter	85ml	$5 \times 10^{-4} \text{ m}^2$
From the outlet of hemofilter to the inlet of blood bag	5ml	$1.25 \times 10^{-5} \text{ m}^2$
Blood bag	Variable	$5 \times 10^{-3} \text{ m}^2$

Table 4. Structural parameters of the dilution-filtration system used in the calculation

Surface area of RBC ( $A_c$ )	$135 \times 10^{-12} \text{ m}^2$ <sup>a</sup>
Hydraulic permeability of cell membrane ( $L_p$ )	$1.74 \times 10^{-12} \text{ m/Pa/s}$ <sup>a</sup>
Isotonic volume of RBC ( $V_{iso}$ )	$98.3 \times 10^{-18} \text{ m}^3$ <sup>a</sup>
Solid volume of RBC ( $V_{cb}$ )	$0.283 \times V_{iso}$ <sup>a</sup>
Glycerol permeability to cell membrane ( $P_s$ )	$6.61 \times 10^{-8} \text{ m/s}$ <sup>a</sup>

<sup>a</sup> From literature (Papanek, 1978);

Table 5. Membrane parameters of human RBC used in the calculation

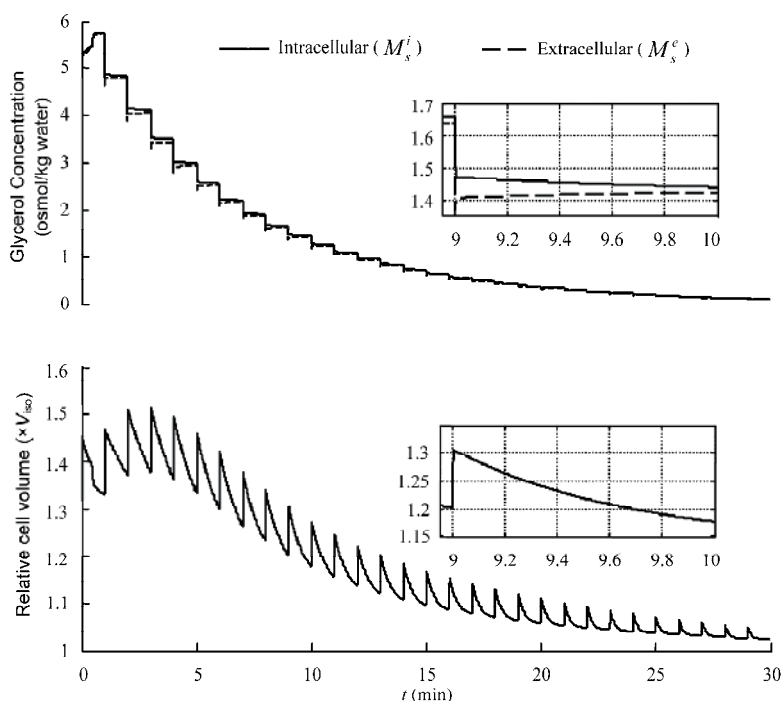

Fig. 18. Simulated glycerol concentration variation and cell volume excursion in  $CV_1$  (initially at the diluting point) during a dilution-filtration process.

## Experiments

Venous human blood was collected from healthy, adult blood donors in the Red Cross Transfusion Center of Heifei. For each donor, up to 200ml whole blood was collected into CPDA-1 anticoagulant solution in PVC plastic bag, and stored for up to 24 hours at 4°C. Then it was centrifuged at  $1615\times g$  for 4 minutes, and the platelets, leukocytes and plasma were removed to produce a hematocrit of  $75\pm 5$  percent.

Each of the RBC suspensions was transferred into a 400-ml plastic bag, and then it was glycerolized by 57.1% w/v glycerol solution with a volume ratio of 2:1 (glycerol to blood) to achieve a final glycerol concentration about 40% (w/v) and a hematocrit of 25%-30%. Subsequently the blood bag was covered by PE foam sheet (thickness: 5mm) and then placed into a metal box (size: 200mm $\times$ 150mm $\times$ 20mm). After 30 minutes of equilibrium, the metal box was transferred to a -80°C freezer (MDF-U52V, SANYON, Japan) and the RBC suspension was frozen gradually. After cryopreservation in the freezer for 2~7 days, the RBC suspension was taken out and thawed in a 37°C water bath for about 10 minutes with gentle agitating.

Each unit of the thawed blood was deglycerolized with the dilution-filtration system as shown in Fig. 16, and the operation protocol was theoretically optimized. A typical experimental conditions ( $V_b^0 = 200\text{ml}$ ,  $h^0 = 30\%$ ,  $M_s^0 = 6.28$  Osmol/kg water) was studied first to reveal the general law. To evaluate the effect of each operation parameter, different protocols were applied respectively. Fig.19 shows that time cost is significantly reduced but maximum cell volume grows directly along with diluent flow rate increases, i.e. the washing efficiency can be

improved by applying higher diluent flow rate but more hemolysis may be induced. Thus the diluent flow rate has to be carefully selected to achieve the optimal result. Comparatively, the effect of blood flow rate is not so complicated. Increasing of blood flow rate has little effect on glycerol clearance, but helps to reduce the maximum cell volume excursion.

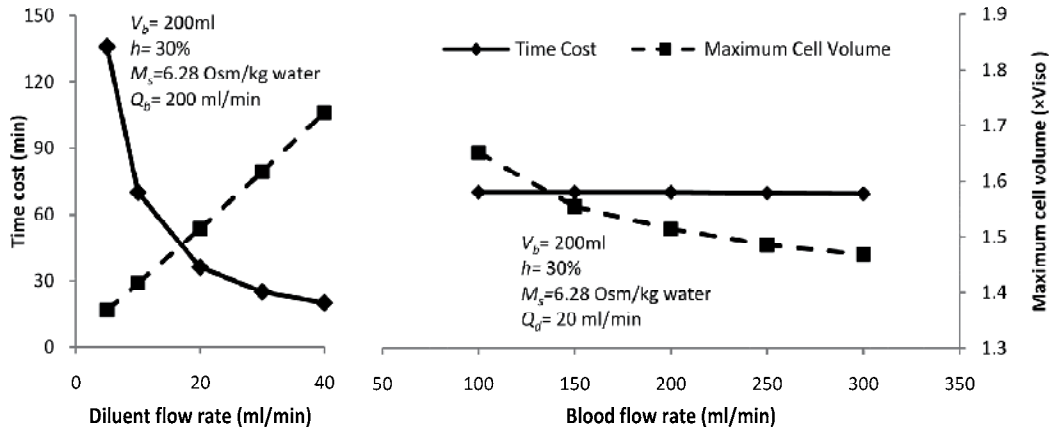

Fig. 19. Variations of time cost (real line and left Y-axis) and maximum cell volume (dash line and right Y-axis) with blood or diluent flow rates as parameters.

On the other hand, the effect of the operation parameters is also highly related to the blood conditions, especially the glycerol concentration. As shown in Fig.20, the same operation protocol ( $Q_b=200\text{ ml/min}$  and  $Q_d =20\text{ml/min}$ ) is applied to several different conditions, in which  $V_b^0 =200\text{ml}$ ,  $h^0 =30\%$ , and  $M_s^0$  varies from  $0.56\text{ Osmol/kg water}$  (5% w/v) to  $6.28\text{ Osmol/kg water}$  (40% w/v). When the glycerol concentration decreases, both the glycerol clearance and the maximum cell volume are reduced (glycerol clearance is defined here as the difference of initial and final numbers of osmoles of glycerol in blood over time cost). This phenomenon indicates us that along with the glycerol concentration drops during washing, diluent flow rate can be continuously increased to speed up the process without inducing extra cell volume excursion.

Based on the analysis above, it can be concluded that to achieve the optimal deglycerolization it is important to: a) use a low diluent flow rate at first, and stepwise increase it as CPA concentration drops; b) always use a high blood flow rate. The detailed operation parameters of the optimal protocol can be found out by the theoretical model with some practical constraints. During the in-vitro experiments, operation protocol for each unit was optimized theoretically according to the specific experimental conditions as well as the following constraints: maximum cell volume: 1.35 times of the isotonic volume ( $V_{iso}$ ) of RBCs; maximum flow rate of pumps:  $200\text{ ml/min}$  and maximum ultrafiltrate flow rate of hemofilter:  $40\text{ ml/min}$ . The value of upper cell volume level was conservatively selected in order to achieve the best cell recovery rate, although the washing efficiency may be limited.

Samples were taken before and after deglycerolization. Cell count and hematocrit were measured by a hematology Analyzer (Ac·T diff II TM, Beckman COULTER®) The Freeze-Thaw-Wash (FTW) cell count recovery rates were calculated by comparing the total cell counts

after thawing to that after washing (Valeri et al, 2001). Residual glycerol concentration in the washed blood was measured by a glycerol assay kit (K-GCROL, Megazyme®) and a spectrophotometer (756MC UV-VIS, Scientific Instrument®, Shanghai, China).

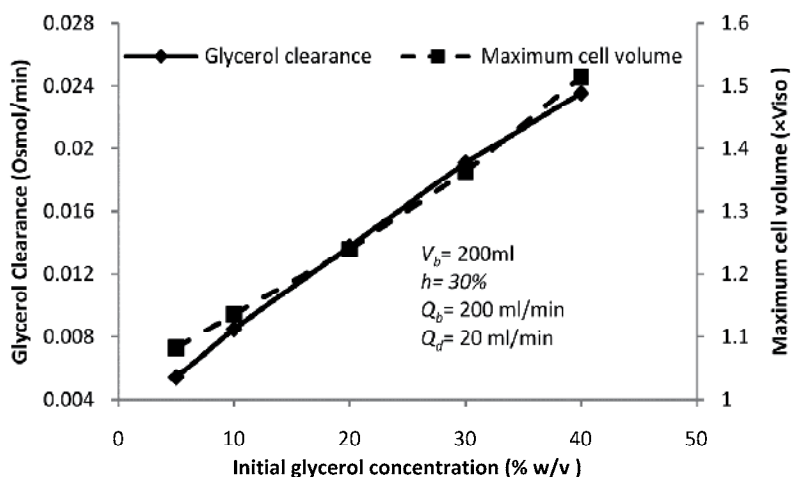

Fig. 20. Variations of glycerol clearance (real line and left Y-axis) and maximum cell volume (dash line and right Y-axis) with glycerol concentration as a paramter.

## 2.4 Results

A total number of ten units of blood were cryopreserved and deglycerolized by the dilution-filtration method, and the results are shown in Table 6. The residual glycerol concentration ( $5.57 \pm 2.81$  g/L,  $n=10$ ) is obviously lower than the standard value (10g/L) indicated by American association of blood banking (AABB). During the optimization of the operation procedures, the maximum cell volume constraints was critically applied ( $1.35 \times \text{Viso}$ ) for the best of cell recovery, and thus the deglycerolizing efficiency is limited. However, each of the unit was processed within an hour, which is similar to the automatic centrifuging method (Valeri et al, 2001). The cell count recovery rate is  $91.19 \pm 3.57\%$  ( $n=10$ ). Comparing to the reported methods (Diafiltration method: 70% (Castino et al, 1996), dialysis method, no in vitro data was presented (Ding et al, 2007, 2010), manual centrifuging method:  $>80\%$  (Brecher, 2002), and automatic centrifuging method  $89.4 \pm 3.0\%$  (Valeri et al, 2001)), the recovery rate indicates an obviously advantage of our method in cell safety.

UNITS	Thawed Blood Volume (ml)	Thawed Blood Hct (%)	Cell Count Recovery (%)	Residual Glycerol (g/L)
1	221.8	30	93.64	2.60
2	204.1	27	85.92	3.39
3	229.8	29	91.64	12.26
4	219.0	23	90.91	4.90
5	217.6	25	91.38	3.39
6	210.0	28	90.76	6.56
7	216.7	24	81.60	3.80
8	200.5	29	94.18	7.34
9	204.5	21	92.24	5.35
10	205.0	30	93.80	6.08
<b>Mean</b>	212.9	27	91.19	5.57
<b>S.D.</b>	9.49	3	3.57	2.81

Table 6. *In-vitro* experiments of deglycerolization with dilution-filtration method

## 2.5 Discussion

An optimized method for addition and removal glycerol from cryopreserved human spermatozoa has been illustrated as an example. Although the mechanism(s) of the osmotic injury during cryopreservation is not clearly understood, the hypothesis has been tested and confirmed, i.e. human sperm volume excursion can be used as an indicator to predict possible osmotic injury to spermatozoa during glycerol addition and removal processes. Hence, the procedures used for testing the hypothesis provide a methodology to predict optimal protocols for cryoprotective agent addition/removal.

The FVS, multi-step procedure for the addition of glycerol to human spermatozoa before cryopreservation is a conventional, commonly used technique, i.e. 'drop by drop' (stepwise) addition of a solution with a relatively high glycerol concentration (the volume of each 'drop' is roughly constant) to the spermatozoa or sperm suspension in order to achieve a 0.6-1.0 M glycerol concentration in the final sperm suspension. In practice, the frozen-thawed sperm samples containing glycerol are either washed for intrauterine insemination or four in-vitro fertilization or directly transferred into the lower female reproductive tract for artificial insemination (e.g. intercervical insemination). In both cases, the glycerol is abruptly removed from spermatozoa by direct exposure to near isotonic conditions. In the example, it was predicted by computer simulation, and confirmed experimentally, that a one-step removal of glycerol would cause a high frequency of sperm motility loss even without freezing. Based on the results, the FMS removal ( $\geq 8$  steps) of 1.0 M glycerol is recommended. Within the scope of the present investigation, a four-step FMS addition of glycerol to spermatozoa to achieve a final 1.0 M glycerol concentration and an eight-step

FMS removal of 1.0 M glycerol from spermatozoa were predicted and shown to be acceptable procedures which minimize osmotic injury. From calculations, the minimum or maximum cell volumes after each step of FVS addition or removal were shown to be unequal, some of which may exceed the lower or upper volume limits of the cells. In contrast, from calculations, the minimum or maximum cell volumes after each step of FMS addition or removal of glycerol were shown to be relatively even (Figures 12 and 13). For a fixed number of steps, the minimum or maximum of cell volume excursion during glycerol addition or removal using the FMS approach is much smaller than that using the FVS approach (see Figures 12 and 13).

In the example, it was postulated that the sperm osmotic injury as a function of cell volume excursion must be determined to predict the optimal glycerol addition and removal procedures. However, the definition and determination of 'sperm injury' is dependent upon the assays used. In the example, sperm motility was used as a standard of sperm viability because of its relatively high sensitivity to osmotic changes and the requirement of sperm motility for functional viability. If sperm membrane integrity was chosen as the endpoint to evaluate the sperm viability, as shown in Figure 7, different osmotic tolerance limits would be obtained. One can readily repeat the same procedures to predict the extent to which spermolysis is caused by the different glycerol addition/removal procedures used in the example, based on the information provided in Figure 5. For example, it was found (Figure 7) that >85% of spermatozoa maintained membrane integrity when they were returned to isotonic condition after having been exposed to anisotonic conditions ranging from 90 and 700 mOsmol. The corresponding sperm volume excursion range was 0.7-2.1 times the isotonic sperm volume (Figure 9). From Figures 12 and 13, it can be seen that a one-step addition and one-step removal of 1.0 M glycerol would result in a minimum relative sperm volume of 0.72 and maximum volume of 1.68 respectively, which did not exceed the sperm volume excursion range 90.7-2.1 times relative volume) for maintaining >85% sperm membrane integrity. Based on this information, one can predict that the majority (>85%) of spermatozoa would maintain membrane integrity even using one-step addition and one-step removal of glycerol.

A dilution-filtration system for removing CPAs from cryopreserved cell suspension was also introduced here. The system realized continuous processing of cell suspension and the dilution & filtration were conducted simultaneously, thus it can achieve much better efficiency than traditional multi-step centrifuging methods. Moreover, dilution in the system is conducted to cell suspension flow in tubing but not whole suspension in container, thus the mixing process should be much rapider and then the osmotic disequilibrium during dilution can be significantly reduced.

A theoretical model was established to simulate the specific process. Based on the model, cell volume excursion and the variation of CPA concentration during the dilution-filtration process can be simulated. Theoretical analysis indicates the operation parameters, especially the flow rate of diluent, are critical for the dilution-filtration method. In the previous studies concerning removing CPAs with hollow fibers (Castino et al, 1996; Arnaud et al 2003; Ding et al, 2007, 2010 ), only the protocols with constant flow rates were discussed. However, it was found to be difficult to balance the requirements in removing efficiency and cell safety. This problem also exists in the presented dilution-

filtration method. Removing efficiency can be improved by using higher diluent flow rate, but the cell recovery rate may be seriously reduced in the way. Besides, when using a constant diluent flow rate, the profile of glycerol concentration is nearly exponential, i.e., the removing efficiency starts at the highest value but gradually decreases as the process going on. However, when using a stepwise increased diluent flow rate, the removing efficiency can be maintained at a high level for a quite long period. Moreover, theoretical analysis also indicates stepwise increasing of the diluent flow rate may not cause any extra cell damage. Therefore, a stepwise increased diluent flow rate is necessary to achieve both high cell recovery rates and efficient glycerol clearance when using the dilution-filtration system. In addition, it was also deduced by the theoretical analysis that the removing effect of an operation protocol is highly related to the initial volumes and cell densities of cell suspensions. Therefore, the optimal operation protocols should be specialized and various from case to case. The theoretical model provides an effective tool to find out the optimal protocols for given applications.

The system was also investigated experimentally with deglycerolization from cryopreserved blood, and the operation procedures were optimized based on the theoretical model. It is clearly indicated by the results that the dilution-filtration method is safe and efficient for deglycerolization from cryopreserved RBCs. Comparing to the automatic centrifuging method, the cell recovery rate and removing efficiency are similar, but the equipment cost of the dilution-filtration system is much lower and thus it can be applied in more areas. We can also believe that with properly selected operation parameters, this system can also be applied to various CPA removal applications. In addition, all the media are processed in a closed system, and thus the system should have further advantages in avoiding contamination. It is hopeful for the cells to have a long shelf life after washing. These suppositions will be verified by further experiments.

### 3. References

- Arnaud, F.G. and Pegg, D.E. (1990) Permeation of glycerol and propane-1,2-diol into human platelets. *Cryobiology*, 27, 107-118.
- Arnaud, F., Kapnik, E., and Meryman, H. T., 2003, "Use of hollow fiber membrane filtration for the removal of DMSO from platelet concentrates," *Platelets*, 14(3), pp. 131-138.
- Bavister, B.D., Leibfried, M.L. and Lieberman, G. (1983) Development of preimplantation embryos of the golden hamster in a defined culture medium. *Biol. Reprod.*, 28, 235-247
- Brecher, M. E., 2002, *Technical manual of the American Association of Blood Banks*. 14th ed., American Association of Blood Banks, Bethesda.
- Castino, F., and Wickramasinghe, S. R., 1996, "Washing frozen red blood cell concentrates using hollow fibers," *Journal of membrane science*, 110(2), pp. 169-180.
- Crister, J.K., Huse-Benda, A.R., Aaker, D.V., Arneson, B.W. and Ball G.D. (1988a) Cryopreservation of human spermatozoa, 3. The effect of cryoprotectants on motility. *Fertil. Steril.*, 50, 314-320.
- Crister, J.K., Colvin, K.E. and Crister, E.S. (1988b) Effect of sperm concentration on computer assisted semen analysis results. Abstracts of the 1988 Annual Meeting of American Society of Andrology. *J. Androl.*, 9 (Suppl.), Abstr. 105, p.45.



- Curry, M.R. and Watson, P.F. (1994) Osmotic effects on ram and human sperm membranes in relation to thawing injury. *Cryobiology*, 31, 39-46.
- Daugirdas, J. T., Blake, P., Ing, T. S. and Blagg, C., 2006, *Handbook of Dialysis*, Fourth Edition., Lippincott Williams & Wilkins, Philadelphia, pp.265-275.
- Ding, W. P., Yu, J. P., Woods, E., Heimfeld, S., and Gao D. Y., 2007, "Simulation of removing permeable cryoprotective agents from cryopreserved blood with hollow fiber modules," *Journal of membrane science*, 288(1), pp. 85-93.
- Ding, W. P., Zhou, X. M., Heimfeld, S., Reems, J., and Gao D. Y., 2010, "A Steady-State Mass Transfer Model of Removing CPAs from Cryopreserved Blood with Hollow Fiber Modules," *Journal of Biomechanical Engineering*, 132(1), pp. 011002
- Du, Junying, Kleinhans, F.W., Mazur, P. and Crister, J.K. (1993) Osmotic behavior of human spermatozoa studied by EPR. *Cryo-letters*, 14, 285-294.
- Du, Junying, Kleinhans, F.W., Mazur, P. and Crister, J.K. (1994) Human spermatozoa glycerol permeability and activation energy determined by electron paramagnetic resonance. *Biochim. Biophys. Acta*, 1994, 1-11.
- Gao, D.Y., Mazur, P., Kleinhans, F.W., Watson, P.F., Noiles, E.E. and Crister, J.K. (1992) Glycerol permeability of human spermatozoa and its activation energy. *Cryobiology*, 29, 657-667.
- Gao, D.Y., Ashworth, E., Watson, P.F., Kleinhans, F.W., Mazur, P. and Crister, J.K. (1993) Hyperosmotic tolerance of human spermatozoa: separate effect of glycerol, sodium chloride and sucrose on spermolysis. *Biol. Reprod.*, 49, 112-123.
- Gao, D.Y., Liu, J., Liu, C., McGann, L.E., Watson, P.F., Kleinhans, F.W., Mazur, P., Crister E.S. and Crister J.K. (1995). Prevention of osmotic injury to human spermatozoa during addition and removal of glycerol, *Human Reproduction* 10, 1109-1122.
- Garner, D.L., Pinkel, D., Johnson, L.A. and Pace, M.M. (1986) Assessment of spermatozoal function using dual fluorescent staining and flow cytometric analyses. *Biol. Reprod.*, 34, 127-138.
- Gilmore, J.A., Liu, J., Gao, D.Y. and Crister, J.K. (1997) Determination of optimal cryoprotectant and procedures for their addition and removal from human spermatozoa. *Human Reproduction* 12, 112-118.
- Gilmore, J.A., McGann, L.E., Liu, J., Gao, D.Y., Peter, A.T., Kleinhans, F.W., and Crister, J.K. (1995) Effect of cryoprotectant solutes on water permeability of human spermatozoa. *Biol. Reprod.* 53, 985-995.
- Jequier, A. and Crich, J. (1986) Computer assisted semen analysis (CASA). In *semen Analysis: A practical Guide*. Blackwell Scientific, Boston, pp. 143-149.
- Jeyendran, R.S., Van der Ven, H.H., Perez-Pelaez, M., Crabo, B.G. and Zaneveld, L.J.D. (1984) Development of an assay to assess the functional integrity of the human sperm membrane and its relationship to other semen characteristics. *J. Reprod. Fertil.*, 70, 219-228.
- Katkov, I. I., 2000, "A Two-Parameter Model of Cell Membrane Permeability for Multisolute Systems," *Cryobiology*, 40(1), pp. 64-83.
- Katkov, I.I., Katkova, N., Crister, J.K., and Mazur, P. (1998a) Mouse spermatozoa in high concentrations of glycerol: Chemical toxicity vs osmotic shock at normal and reduced oxygen concentration. *Cryobiology* 37, 325-338.

- Katkov, I.I. (1998b) Cell suspensions in high concentrations of a permeable cryoprotectant: Optimization of addition and dilution protocols. *Cryobiology* 37, 403-404
- Kedem, O. and Katchalsky, A. (1958) Thermodynamic analysis of the permeability of biological membrane to nonelectrolytes. *Biochim. Biophys. Acta*, 27, 229-246.
- Kleinhans, F. W., 1998, "Membrane Permeability Modeling: Kedem-Katchalsky vs a Two-Parameter Formalism," *Cryobiology*, 37(4), pp. 271-289.
- Kleinhans, F.W., Travis, V.S., Du, Junying, Villines, P.M., Colvin, K.E. and Criter, J.K. (1992) Measurement of human sperm intracellular water volume by electron spin resonance. *J. Androl.* 13, 498-506.
- Leibo, S.P. (1981) Preservation of ova and embryos by freezing. In Brackett, E.G. Seidel, G.E. and Seidel, S.M. (eds), *New Technologies in Animal Breeding* Academic Press, New York, pp. 127-139.
- Leibo, S.P. (1986) Cryobiology: preservation of mammalian embryos. *Basic Life Sci.*, 37, 251-272.
- Leibo, S.P. and Mazur, P. (1978) Methods for the preservation of mammalian embryos by freezing. In Daniel, J.C., Jr (ed.), *Methods in Mammalian Reproduction*. Academic Press, New York, pp. 179-201.
- Mazur, P. (1984) Freezing of living cells: mechanism and implications. *Am. J. Physiol.* 247, C125-C142.
- Mazur, P. and Leibo, S.P. (1977) Mechanisms of freezing damage in bacteriophage T4 (Discussion). In Elliott, K. and Whelan, J. (eds), *The Freezing of Mammalian Embryos*. Ciba Foundation Symposium No. 52. Elsevier, Amsterdam, pp. 255-226.
- Mazur, P. and Schneider, U. (1984) Osmotic consequences of cryoprotectant permeability and its relation to the survival of frozen-thawed embryos. *Theriogenology*, 21, 68-79.
- Mazur, P. and Schneider, U. (1986) Osmotic responses of preimplantation mouse and bovine embryos and their cryobiological implications. *Cell Biophys.*, 8, 259-284.
- Mazur, P., Leibo, S.P. and Chu, E.H.Y. (1972) A two-factor hypothesis of freezing injury. *Exp. Cell Res.* 71, 345-355.
- McGann, L.E., Turner, A.R. and Turc, J.M. (1982) Microcomputer interface for rapid measurement of average volume using an electronic particle counter. *Med. Biol. Eng. Comput.*, 20, 117-120.
- Meryman, H.T. (1970) The exceeding of a minimum tolerable cell volume in hypertonic suspension as a cause of freezing injury. In Wolstenholme, G.E.W. and O'Connor, M. (eds), *The Frozen Cell*. CIBA Foundation Symposium. Churchill, London, pp. 51-67.
- Meryman, H. T., 2007, "Cryopreservation of living cells: principles and practice," *Transfusion*, 47, pp. 935-945.
- Meryman, H. T., and Hornblower M., 1972, "A method for freezing and washing red blood cells using a high glycerol concentration," *Transfusion*, 12(3), pp. 145-156.
- Meryman, H. T., and Hornblower, M., 1977, "A simplified procedure for deglycerolizing red blood cells frozen in a high glycerol concentration," *Transfusion*, 17(5), pp. 438-442.

- Muldrew, K. and McGann, L.E. (1994) The osmotic rupture hypothesis of intracellular freezing injury. *Biophys. J.*, 66, 532-541.
- Myrthe, T.W., and Barry A. B. (2004) Step-wise dilution for removal of glycerol from fresh and cryopreserved equine spermatozoa. *Animal Reproduction Science* 84, 147-156.
- Noiles, E.E., Mazur, P., Watson, P.F., Kleinhans, F.W. and Crister, J.K. (1993) Determination of water permeability coefficient for human spermatozoa and its activation energy. *Biol. Reprod.*, 48, 99-109.
- Papanek, P. T., 1978, "The water permeability of the human erythrocyte in the temperature range +25 °C to -10°C," Ph.D. thesis, MIT.
- Penninchx, P., Poelmans, S., Kerremans, R. and De Loecher, W. (1984) Erythrocyte swelling after rapid dilution of cryoprotectants and its prevention. *Cryobiology*. 21, 25-32.
- Polge, C. Smith, A.U. and Parkes, A.S. (1949) Revival of spermatozoa after vitrification and dehydration at low temperatures, *Nature*, 164, 666-676.
- Preston, G.M., Carroll, T.P., Guggion, W.B., and Agre, P.(1992) Appearance of water channels in *Xenopus* oocytes expressing red cell CHIP 28. *Science* 256, 385-387.
- Rowe, A.W., Eyster, E. and Kellner, A. (1968) Liquid nitrogen preservation of red blood cells for transfusion: a low glycerol-rapid freeze procedure. *Cryobiology*, 5, 19-128.
- Sherman, J.K. (1973) Synopsis of the use of frozen human sperm since 1964: state of the art of human semen banking. *Fertil .Steril.*, 24, 397-412.
- Spector, P.C., Goodnight, J.H., Sall, J.P., Sarle, S.W. and W.M. Stanish (1985) The GLM and the Catmod procedure. In SAS Institute, Inc., *SAS User's Guide: Statistics*, 5<sup>th</sup> end. SAS Institute. Inc., Cary, NC. Pp. 403-506.
- Steponkus, P.A. and Wiest, S.C. (1979) Freeze-thaw induced lesions in the plasma membrane. In Lyons, J.M., Graham, D. and Raison, J.K. (eds), *Low Temperature Stress in Crop Plants: The rolle of the Membrane*. Academic Press, New York, pp. 231-350.
- Ternstrom, G., Sjostrand, A., Aly, G., and Jernqvist, A. 1996, "Mutual Diffusion Coefficients of Water + Ethylene Glycol and Water + Glycerol Mixtures," *Journal of chemical and engineering data*, 41(4), pp. 876-979.
- Valeri, C. R., 1975, "Simplification of the methods for adding and removing glycerol during freeze-preservation of human red blood cells with the high or low glycerol methods: biochemical modification prior to freezing," *Transfusion*, 15(3), pp. 195-218.
- Valeri, C. R., and Ragno, G., 2006, "Cryopreservation of human blood products," *Transfusion and apheresis science*, 34(3), pp. 271-287.
- Valeri, C. R., Ragno, G., Pivacek, L., and O'Neill E. M., 2001, "In vivo survival of apheresis RBCs, frozen with 40-percent (wt/vol) glycerol, deglycerolized in the ACP 215, and stored at 4 degrees C in AS-3 for up to 21 days," *Transfusion*, 41(7), pp. 928-932.

- Watson, P. F. (1979) The preservation of semen in mammals, in Finn, C. A. (ed.) Oxford Reviews of Reproductive Biology, vol 1. Oxford University Press, Oxford, 283-350.
- Zar, J.H. (1984) Biostatistical Analysis. 2<sup>nd</sup> edn. Prentice-Hall, Inc., Englewood Cliffs, NJ, P. 718.
- Zhou, X. M., Liu, Z., Shu, Z. Q., Ding, W. P., Du, P. A., Chung, J., Liu, C., Heimfeld, S., and Gao, D. Y. (2011) A Dilution-filtration Method for Removing Cryoprotective Agents. J. Biomech. Eng-ASME Trans. 133, 021007.

## **Part 2**

# **Stem Cells and Cryopreservation in Regenerative Medicine**



# Cryopreservation of Human Pluripotent Stem Cells: Are We Going in the Right Direction?

Raquel Martín-Ibáñez<sup>1,2,3</sup>, Outi Hovatta<sup>4</sup> and Josep M. Canals<sup>1,2,3</sup>

<sup>1</sup>*Departament de Biologia Cel·lular, Immunologia i Neurociències, Programa de Teràpia Cel·lular, Facultat de Medicina, Universitat de Barcelona, Barcelona*

<sup>2</sup>*Institut de Investigacions Biomèdiques August Pi i Sunyer (IDIBAPS), Barcelona*

<sup>3</sup>*Centro de Investigación Biomédica en Red Sobre Enfermedades Neurodegenerativas (CIBERNED)*

<sup>4</sup>*Division of Obstetrics and Gynecology, Department of Clinical Science, Intervention and Technology, Karolinska Institutet, K57, Karolinska University Hospital, Huddinge, Stockholm,*

<sup>1,2,3</sup>*Spain*

<sup>4</sup>*Sweden*

## 1. Introduction

The first derivation of human embryonic stem cells (hESCs) (Thomson et al., 1998) and the more recently development of human induced pluripotent stem cells (iPSCs) (Park et al., 2008; Takahashi et al., 2007; Takahashi & Yamanaka, 2006; Wernig et al., 2007; Yu et al., 2007) have marked the beginning of a new era in biomedical research. These two types of human pluripotent stem cells (hPSCs) are characterized by an unlimited capacity to self-renew while retaining their potential to differentiate into almost all cell types of the body (Odorico et al., 2001; Reubinoff et al., 2000; Silva & Smith, 2008). These remarkable properties turn hPSCs into one of the most interesting cell types for toxicology and drug discovery, tissue engineering and regenerative medicine (Battey, 2007; Mountford, 2008). In fact, work with hPSCs has already provided new and exciting developments that may eventually lead to the creation of novel cell-based therapies for the treatment of a wide range of human diseases including Parkinson's and other neurodegenerative diseases, diabetes, cardiac and vascular diseases (Kiskinis & Eggan, 2010; Ronaghi et al., 2010). However, a major challenge for the widespread application of hPSCs is the development of efficient protocols for cryopreservation.

To date, two techniques are mainly applied for the cryopreservation of hPSCs: conventional slow freezing and vitrification. The conventional slow-freezing and rapid-thawing procedure using dimethylsulfoxide (DMSO) as a cryoprotectant is the most commonly used method (Grout et al., 1990; Meryman, 2007). While this established technique is effective for somatic cell lines and even murine embryonic stem cells (mESCs), hematopoietic and mesenchymal human stem cells, this is not the case for hPSCs, due to low recovery rates and high levels of differentiation (Berz et al., 2007; Reubinoff et al., 2001; Richards et al., 2004; Thirumala et al., 2010). In contrast, vitrification of hPSCs by the "open pulled straw" method

using high cryoprotectant concentrations together with flash-freezing in liquid nitrogen has reported higher cell survival rates (Li et al., 2010b; Reubinoff et al., 2001; Richards et al., 2004). However, there are several disadvantages preventing the widespread use of this technique. First, high concentrations of cryoprotectors, which are cytotoxic above 4°C, are needed. Second, these procedures are tedious to perform manually. Additionally, as vitrification is mostly performed in open pulled straws, contact between the liquid nitrogen and the cells is unavoidable, which carries the risk of contamination. Finally, and one of the most limiting disadvantages of this technique is that it is clearly unsuited for freezing bulk quantities of hPSCs.

During the last decade, several groups have been studying different approaches to improve the above described cryopreservation protocols. In the present work we will review the recent advances in the cryopreservation field trying to point out how a better understanding of the sensitivity of hPSCs to the cryopreservation process will help to develop more efficient protocols.

## 1.1 Human pluripotent stem cells

### 1.1.1 Human embryonic stem cells

The pioneering work on mESCs, and later advances in culturing techniques that were developed to culture nonhuman primate embryonic stem cell lines eventually led to the first successful generation of hESC lines by Thompson and coworkers and two years later by Reubinoff and coworkers (Evans & Kaufman, 1981; Martin, 1981; Reubinoff et al., 2000; Thomson et al., 1995; Thomson et al., 1996; Thomson et al., 1998). These hESCs were derived from human embryos that were produced by *in vitro* fertilization for clinical purposes. HESC lines were karyotypically normal and maintained the developmental potential to contribute to derivatives of all three germ layers, even after clonal derivation and prolonged undifferentiated proliferation (Amit et al., 2000). Since then, hundreds of stem cell lines have been derived world-wide from morula, later blastocyst stage embryos, fresh and cryopreserved supernumerary embryos, single blastomeres and parthenogenetic embryos (Klimanskaya et al., 2006; Lin et al., 2007; Mai et al., 2007; Revazova et al., 2007; Stojkovic et al., 2004; Strelchenko et al., 2004).

HESCs grow in tightly packed colonies and maintain defined borders at the periphery of colonies. High nucleus to cytoplasm ratio and prominent nucleoli are typical features of individual hESCs within colonies. HESCs are also characterized by high telomerase activity and expression of a number of cell surface markers and transcription factors including stage-specific embryonic antigen (SSEA)-4, SSEA-3, TRA antigens, Oct3/4, Nanog and absence of hESCs negative markers such as SSEA-1 (Carpenter et al., 2003; Chambers et al., 2003; Draper et al., 2004; Heins et al., 2004; Nichols et al., 1998). Functional confirmation of the multipotent nature of hESCs is generally achieved by examining their potential to differentiate into all three germ layers (ectoderm, mesoderm and endoderm) both *in vitro* and *in vivo*. *In vitro*, hESCs are allowed to randomly differentiate as embryoid bodies (EBs), which are aggregates of cells grown in suspension culture, followed by immunocytochemical analysis, or measurement of expression of genes associated with the three germ layers by RT-PCR (Reubinoff et al., 2000). The *in vivo* test for pluripotency of hESCs is normally teratoma formation in immunocompromised mice (Bosma et al., 1983).



### 1.1.2 Human induced pluripotent stem cells

An important revolution in the stem cell research field was accomplished when several groups in different studies demonstrated that using a cocktail of four factors, somatic cells could be reprogrammed into iPSCs (Maherali et al., 2007; Okita et al., 2007; Park et al., 2008; Takahashi et al., 2007; Takahashi & Yamanaka, 2006; Wernig et al., 2007; Yu et al., 2007). Consequently, it was shown that such cells could be generated from patient-specific cells for a wide variety of diseases (Kiskinis & Eggan, 2010; Raya et al., 2009; Raya et al., 2010) and from a wide variety of somatic cell types (Sun et al., 2010). These cells are morphologically similar to hESCs, express typical hESC-specific cell surface antigens and genes, differentiate into multiple lineages *in vitro*, and form teratomas containing differentiated derivatives of all three primary germ layers when injected into immunocompromised mice. Indeed, these new pluripotent cell lines satisfy all the original criteria proposed for hESCs (Thomson et al., 1998). Nevertheless, some differences have been observed between hESCs and iPSCs (Chin et al., 2009); but it remains unclear whether the small percentage of genes that are differentially expressed between these two types of hPSCs are shared among different lines and whether these differences are biologically significant.

Developing iPSCs into therapeutic reagents faces a number of practical hurdles, including risks associated with cell processing, the difficulty of ensuring the purity and characteristics of the reprogrammed population and the safety and efficacy of reprogrammed cells *in vivo* (Condic & Rao, 2008; Rao & Condic, 2008; Rao & Condic, 2009). Moreover, a case of rejection has been recently described after iPSCs autologous transplantation (Apostolou & Hochedlinger, 2011). Nonetheless, there is cause for considerable optimism that patient-specific iPSC lines will both enhance the study of human diseases and advance these studies toward clinical applications.

## 1.2 Cryopreservation of hPSCs

Cryopreservation is the process of cooling and storing cells, tissues or organs at sub-freezing temperatures, below  $-80^{\circ}\text{C}$  and typically below  $-140^{\circ}\text{C}$ , to maintain viability (Baust et al., 2009). The freezing process involves complex phenomena of water crystallization and changes in solute concentration both outside and inside the cell that can be detrimental to cell survival. In addition, exposure to low temperatures has been reported to induce a stress response resulting in biomolecular-based cell death for different cell types (Baust et al., 2001; Fu et al., 2001; Paasch et al., 2004; Xiao & Dooley, 2003).

In general, the major steps used in cryopreservation of most cell types can be summarized as follows (figure 1): i) harvesting the cells, ii) addition of cryoprotective agents within a carrier media to the cell suspension, iii) ice crystal induction in cell suspension following a determined cooling rate (ranging from  $-1$  to  $-10^{\circ}\text{C}/\text{min}$ ), iv) long-term storage at cryogenic temperatures (normally in liquid nitrogen), v) rapid thawing by warming the cell suspension in a  $37-40^{\circ}\text{C}$  water bath, vi) removal of cryoprotective agent by centrifugation and vii) seeding down the cells to allow culture growth (Gao et al., 1998; Hubel, 1997).

Cryo-injury can be due to one or a combination of the following processes: 1) cytotoxicity of cryoprotective agents (Muldrew & McGann, 1994; Schneider & Maurer, 1983); 2) osmotic injury due to excursion of cryoprotective agents upon freeze-thawing (Gao et al., 1995; Mazur & Schneider, 1986); 3) intracellular ice formation in the cooling process (Fujikawa,

1980; Mazur et al., 1972) and 4) recrystallization of the intracellular ice during the warming process (Mazur & Cole, 1989; Trump et al., 1965). In addition, recent studies have linked numerous stress factors associated with cryopreservation to known initiators of molecular-based apoptotic cell death processes (Baust et al., 2009).

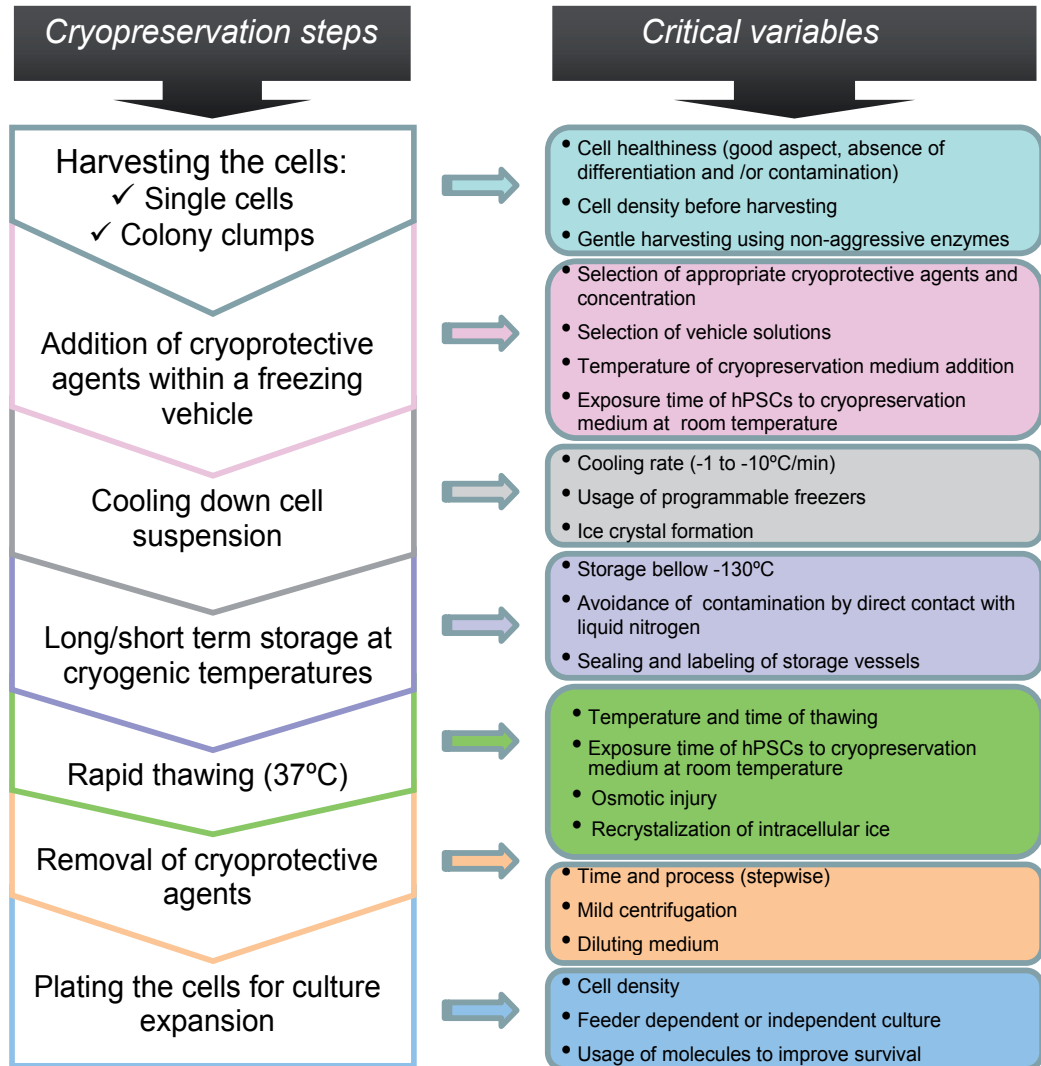

Fig. 1. Representative diagram of the main steps involved in a general cryopreservation process and the critical variables that should be considered in order to preserve cells with good recovery rates.

## 2. Sensitivity of hPSCs to cryopreservation

The techniques employed for the cryopreservation of hPSCs which include slow freezing-rapid thawing and vitrification, have been shown to be refractory for these cells that present

very low survival rates (5-20% and 25-75% respectively) and many of the cells that do survive differentiate upon thawing and expansion (Reubinoff et al., 2001; Richards et al., 2004). The low efficiency of hPSCs cryopreservation has been attributed, in part, to the highly “cooperative” nature of these cells (as comparable with mESCs), which appear to require intimate physical contact between them within the colony (to permit cell-cell signaling) and an optimum clump size of about 100-500 cells during cryopreservation and serial passage (Amit et al., 2000; Reubinoff et al., 2000). All these statements mean that we are dealing with a cell type that presents extremely high sensitivity to cryopreservation. Therefore, the arising questions are: why are hPSCs so vulnerable to the cryopreservation process? And which are the processes involved in the low survival rates of hPSCs after cryopreservation?

Heng et al postulated for the first time that apoptosis instead of cellular necrosis, was the major mechanism inducing the loss of viability of cryopreserved hESCs during freeze-thawing with conventional slow-cooling protocols (Heng et al., 2006). They showed that most of the cells were viable (~98%) immediately after thawing (determined by the Trypan blue dye exclusion method) and that cell viability was gradually decreasing with time in culture at 37°C. Moreover, the kinetics of cell death could be reversibly slowed by a reduction in the temperature at which the cells were held post-thaw, indicating an apoptotic mechanism for cell death rather than an unregulated necrotic process. Based on these previous results, Xu et al investigated the apoptotic pathways activated during cryopreservation (Xu et al., 2010a). They described that the largest effect observed, mainly due to the freezing step, was an increase in the level of reactive oxygen species in hESCs. This presumably leads to the activation and translocation of p53 as strong expression of this protein was seen in the nucleus of thawed cells. Consequently, Caspase 9 was activated and a significant increase was also observed after thawing. In addition, Caspase 8 activity showed a similar increase post-thaw, indicating the possible activation of the extrinsic apoptotic pathway. They also stated that the elevated levels of F-actin observed during freezing could result in changes in apoptotic signals. These results led the authors to conclude that apoptosis in cryopreserved hESCs was induced through both, the intrinsic and extrinsic pathways (Xu et al., 2010a).

However, a remaining question is unanswered: why hPSCs are so sensitive to apoptosis compared to mESCs or other cell lines? In order to answer this issue, Wagh et al performed detailed microarray studies on hESCs at different time points after thawing and compared their transcriptomes with control cells that did not go through the cryopreservation process (Wagh et al., 2011). Viability, stemness, colony morphology and proliferation were also monitored at different times post-thawing. They observed a full recovery of the phenotypes of cryopreserved hESCs after 5 days of cultivation. However, the number of colonies was significantly smaller in the frozen hESCs compared to control groups. Furthermore, the colony growth rate was also reduced. Gene expression analysis showed very similar transcriptomes for the surviving fraction of 30 minutes frozen-thawed hESCs and the control unfrozen cells. Therefore, they concluded that the transcriptome of the surviving hESCs is preserved during cryopreservation. On the other hand, increases in the number of the up- and down-regulated genes occur continuously within 24 h after thawing and culturing, and those genes are declined or maintained within 48 h. This observation favored the hypothesis that physical cellular damage induced by freezing and/or thawing inhibits proper attachment during cultivation resulting in an induction of anoikis apoptotic cell

death despite an almost stable transcriptome. Supporting this theory the analysis of the microarray showed differences in the expression of genes involved in cell communication, cell growth and maintenance, cell death, cell differentiation and cell proliferation (Wagh et al., 2011). In agreement, Li et al showed that increased cellular adhesion induced by the Rho associated kinase (ROCK) inhibitor Y-27632 enhances the survival of single hESCs after thawing (Li et al., 2009). To demonstrate this, they treated cryopreserved hESCs simultaneously with Y-27632 and EGTA, a calcium chelant that disrupts cadherin activity and therefore cell adhesion. This double treatment significantly reduced the capacity of hESCs to form colonies and cell viability after thawing (Li et al., 2009). These results point to a high sensitivity of cryopreserved hPSCs to the loss of adherence between cells and/or to the substrate, resulting in a detachment induced apoptosis or anoikis.

According to the high differentiation rates experienced by hPSCs after cryopreservation, Wagh et al observed a down-regulation of pluripotency markers such as *nanog*, *sox2* or *klf4* (Wagh et al., 2011). In agreement with these results, it has been shown that the pluripotency marker Oct-4 was significantly decreased after culturing cryopreserved hESCs for several days (Katkov et al., 2006). In addition, the freeze-thaw stress increases the expression of several genes involved in the differentiation processes such as embryonic morphogenesis, neurogenesis, ossification, tissue morphogenesis, regeneration and vasculature development (Wagh et al., 2011).

### **3. Improvement of existing cryopreservation protocols**

Many laboratories have been working over the last 10 years in the development of new cryopreservation protocols for hPSCs. The main aim of the vast majority of these protocols has been the improvement of cell recovery including: an enhancement of cell survival and a reduction of cell differentiation. To this end different approaches have been adopted: development of new cryopreservation protocols such as vitrification, usage of different cryoprotective agents or molecules to improve survival, xeno-free cryopreservation media, cryopreservation of adherent hPSC colonies or single cells and/or utilization of devices to control changes in temperature. Although each of these works (summed up below), provide some improvements in hPSCs recovery after cryopreservation, not many of them have addressed the key question: how the changes introduced in the cryopreservation protocols contribute to the enhancement in cell recovery?

#### **3.1 Vitrification and optimizations of the technique**

One of the first attempts to overcome the low survival rates experienced by hPSCs after cryopreservation using the standard slow freezing-rapid thawing method was the adaptation of the vitrification protocol. This technique was developed for the cryopreservation of bovine ova and embryos (Vajta et al., 1998) and it was successfully adapted for hESCs freezing by Reubinoff and colleagues some years ago (Reubinoff et al., 2001). The protocol requires stepwise exposure of colony fragments to two vitrification solutions of increasing cryoprotectant concentrations. This exposure is sequential and brief (60 and 26 seconds respectively either at room temperature or at 37°C). The common components of the vitrification medium are DMSO and ethylene glycol. The composition of the vehicle solution varies, with differences in sucrose concentration, the presence or absence of serum and the buffer used. Using mixtures of cryoprotectants helps to reduce the

intrinsic toxicity of each, and the method published by Reubinoff et al utilized 20% DMSO, 20% ethylene glycol and 0.5 mol/l sucrose (Reubinoff et al., 2001). However, no studies have been reported so far to determine the permeability of the cells (or colony fragments) to either cryoprotectant, or the intrinsic toxicity of these components to hESCs (Hunt, 2011).

Extremely rapid cooling rates are required to achieve vitrification using this two-component system. This is accomplished by direct immersion into liquid nitrogen of open-pulled straws containing small droplets (typically 1-20  $\mu$ l) of vitrification solution within which the colony fragments (< 10) are held. Straws are then generally transferred to liquid nitrogen for long term storage (Vajta et al., 1997; Vajta et al., 1998).

The thawing process has to be as well, as rapid as possible to avoid ice crystallization. This is accomplished by direct immersion of the vitrified samples into pre-warmed culture medium containing sucrose, followed by stepwise elution of the cryoprotectants using sucrose as an osmotic buffer. An alternative method with direct exposure to growth medium without stepwise elution of the cryoprotectants has also been used with no noticeable deleterious effects (Hunt & Timmons, 2007; Reubinoff et al., 2001).

Vitrification has been adopted by many groups as the method of choice for hPSCs cryopreservation based on several comparative studies reporting recovery rates of undifferentiated colonies of more than 75% after vitrification compared to the 5-10% obtained after slow-cooling and rapid thawing (Li et al., 2010b; Reubinoff et al., 2001; Richards et al., 2004; Zhou et al., 2004). However, this technique presents some limitations: it is labor intensive and technically challenging, it is not suitable for large amounts of cells and the contact between the liquid nitrogen and the cells carries the risk of contaminations (Vajta & Nagy, 2006). Some attempts to improve these limitations have been done so far. One approximation was proposed by Heng et al for the cryopreservation of adherent hESCs colonies (Heng et al., 2005). They designed a culture plate made of detachable screw-cap culture wells resistant to storage at low temperatures in liquid nitrogen envisioned to develop automated systems for handling bulk quantities of cells (Heng et al., 2005). Alternatively, a method combining the large holding volume of slow-cooling rapid-thawing in cryotubs with the high efficiency of vitrification was described by Li et al (Li et al., 2008a). In this protocol hESCs clumps (>70 $\mu$ m) were harvested after passage and transferred to a nylon cell strainer, exposed to vitrification solutions and vitrified by direct immersion in liquid nitrogen. Using this bulk vitrification method, 30 times more hESCs clumps (100-150) can be vitrified in a cell strainer compared to the open pulled straws. In addition, comparable results to those obtained for the classical vitrification method were reported for the recovery rate, the degree of differentiation and the maintenance of the pluripotency of the surviving cells (Li et al., 2008a). A refinement of this technique, using a cryovial fitted with stainless steel mesh, produced similar results (Li et al., 2010a). Although this method is easy and efficient to perform it still presents the limitation of direct contact of the cells with liquid nitrogen increasing the possibility of contamination and cell infection.

In order to avoid direct contact of the vitrification solution with the liquid nitrogen several methods have been developed. Usage of embryo straws sealed in both ends with a commercial plastic bag heat sealer was reported by Richards et al (Richards et al., 2004). This

improvement of the cryopreservation technique presents a similar yield of hESCs recovery after thawing with low differentiation rates comparable with the results of Reubinoff et al (Reubinoff et al., 2001). The usage of cryovials for vitrification has also been explored showing interesting results. Nishigaki et al used a DMSO-based and serum-free vitrification medium to cryopreserve iPSCs in cryovials (Nishigaki et al., 2011). They compared various vitrification solutions containing different concentrations of DMSO, ethylene glycol and polyethylene glycol with knockout serum replacement (KSR) in both DMEM and Euro-collins vehicle solutions. Analysis of the thermal properties of the cryopreservation solutions during the cooling process by differential scanning calorimetry (DSC) indicated that they would vitrify at an optimal cooling rate of  $\sim -125$  °C/min. Recovery rates between 20-30% are described one day after thawing using 40% ethylene glycol and 10% polyethylene glycol in Euro-Collins solution. Furthermore, cryopreserved cells express undifferentiation markers and keep pluripotency (Nishigaki et al., 2011). Therefore, using this protocol the vitrification of large amounts of cells is feasible and avoids the risk of contamination.

### 3.2 Usage of different cryoprotective agents and vehicles

During the cryopreservation course, as the cell suspension is cooled below the freezing point, ice crystals form and the concentration of the solutes in the suspension increases, being both processes damaging for the cells. Cryoprotective agents (CPAs) are necessary to minimize or prevent the damage associated with the freezing process. The mechanisms providing this protection in slow cooling-rapid thawing protocols, although not completely understood, appear to work primarily by altering the physical conditions of both the ice and the solutions immediately surrounding (external to) the cells. In contrast, vitrification overcomes the problems associated with ice crystallization in a different manner. Here cryoprotectants are used in high concentrations preventing ice formation entirely (Baust et al., 2009; Hunt, 2011).

Different CPAs have been identified so far to be used for the cryopreservation of mammalian cells (Klebe & Mancuso, 1983; Matsumura et al., 2010); however, the two most commonly used substances are glycerol and DMSO. Other substances used include sugars, polymers, alcohols and proteins. CPAs can be divided roughly into two different categories: (1) permeating CPAs: substances that permeate the cell membrane (e.g. DMSO and glycerol); and (2) nonpermeating CPAs: impermeable substances (e.g. polyethylen glycol and trehalose); both types present a different impact on the freezing process. Permeating CPAs have a low molecular weight and thus can penetrate the cell membrane and gradually substitute the water present in the cells. The osmolality of the cells is thereby increased, and subsequently, the percentage of extracellular water that can form ice crystals before reaching the osmotic equilibrium is reduced and total dehydration of the cells is prevented. Nonpermeating CPAs cannot penetrate the cell membrane and stabilize the cell by forming a viscous glassy shell around its surface (Hubel, 1997; Karlsson, 2002; Karlsson & Toner, 1996; Meryman, 2007). Therefore, the selection of an appropriate CPA or a combination of them used in optimal concentrations within an effective vehicle solution will determine the efficiency of the cryopreservation process for a given cell type. In this sense, alternatives to DMSO as the cryoprotectant of choice for hPSCs have been tested due to the known effect of this solvent on inducing differentiation and cytotoxicity (Adler et al., 2006). See Table 1 for an overview of CPAs and freezing vehicles used in different protocols describe here.

Trehalose is a natural disaccharide that has been selected as an attractive CPA for several reasons. First of all, it has been shown to be effective in mammalian cell stabilization at low temperatures and water contents. Secondly, trehalose preserves cell viability by different mechanisms than DMSO (Crowe et al., 2001; Sum et al., 2003; Sum & de Pablo, 2003). Finally, trehalose addition to the cryopreservation medium containing DMSO and fetal bovine serum (FBS) has been proven to increase the viability of hematopoietic precursor cells from 7% to 20% and improved membrane integrity in cryopreserved fetal skin cells (Erdag et al., 2002; Zhang et al., 2003). Ji et al showed that trehalose loading into adherent colonies of hESCs prior to cryopreservation results in small, but significant improvements in cell viability when combined with DMSO treatment and high FBS concentrations (Ji et al., 2004). In the same line of results, it has been demonstrated that trehalose addition to the freezing and post-thawing medium of hESC colonies cryopreserved in suspension in freezing medium containing 10% DMSO, increased the recovery rate by ~3 folds (from 15 to 48%) (Wu et al., 2005). These results suggested that the protective mechanism of trehalose addition might be the reduction of osmotic changes during the freezing and thawing process, although this hypothesis has not been demonstrated. The addition of trehalose did not affect the normal karyotype of the cells neither their pluripotency capacity tested by teratoma formation (Wu et al., 2005).

A comparison between four different types of CPAs for iPSCs cryopreservation has recently been described: DMSO, ethylene glycol, propylene glycol and glycerol (Katkov et al., 2011). Interestingly, the toxicity of these four CPAs was analyzed after 30 minutes exposure of a 10% CPA solution at 37°C. The results showed that DMSO was the most toxic CPA for iPSCs while glycerol was the least harmful being the other two CPAs in between. Surprisingly, the protective effect exerted by the same CPAs after cryopreservation of small iPSC clumps by the slow cooling-rapid thawing protocol was the opposite, being DMSO the most protective CPA together with ethylene glycol while glycerol was the least protective one. The same result was obtained when iPSCs previously dissociated with Accutase™ were cryopreserved in the presence of a ROCK inhibitor in combination with the previous mentioned CPAs. Therefore, ethylene glycol was selected as the cryoprotectant of choice since it presents less toxicity than DMSO and exerts similar levels of protection (Katkov et al., 2011). In addition, these results give clear evidence that the low hPSCs recovery rate obtained after cryopreservation is mainly caused by the freezing-thawing procedure, rather than by the process of CPA addition/removal.

The combination of different CPAs has also been tested in comparison to the conventional freezing solution containing 10% DMSO in slow cooling-rapid freezing protocols. Ha et al performed a detailed study about the composition of the cryopreservation medium, initially analyzing the impact of both DMSO and FBS concentration in hESCs recovery (Ha et al., 2005). They reached the conclusion that a combination of 5% DMSO plus 50% FBS was the most effective one sustaining survival rates of 10%. Afterwards, they used this freezing medium composition as a starting point to test different concentrations of other CPAs such as ethylene glycol or glycerol. An increase of 3 fold in the survival rate (around 30%) was obtained when using a combination of 5% DMSO + 50% FBS +10% ethylene glycol that was selected as the most effective cryopreservation medium. Three passages after thawing cryopreserved hESCs retained the key properties and characteristics of hPSCs (Ha et al., 2005).

CPA composition	Freezing vehicle	Addition of other molecules	Cell type	Cell processing	Type of culture	Recovery rate	Reference
10 % EG	Not described	ROCK inhibitor	iPSCs	Colony clumps and single cells	MEF feeder layer	~20-50% recovery <sup>(1)</sup>	(Katkov et al., 2011)
		No		Adherent colonies		~60% recovery <sup>(1)</sup>	
10% DMSO	Growth medium	No	hESC	Colony clumps	MEF feeder layer	60% (30 min) <10% (24 h) <sup>(2)</sup>	(Wagh et al., 2011)
		ROCK inhibitor	hESC	Single cells	Human foreskin feeder layer	50-60% survival <sup>(4)</sup>	(Martin-Ibanez et al., 2008)
			hESC and iPSC		MEF feeder layer and feeder-free culture	7-8 fold increase in the number of recovered cells or colonies <sup>(8)</sup>	(Claassen et al., 2009)
		ROCK inhibitor + P53 inhibitor	hESC	Single cells	MEF feeder layer and feeder-free culture	~80% survival <sup>(5)</sup>	(Xu et al., 2010a)
	90% FCS	ROCK inhibitor	hESC and iPSC	Single cells	Feeder-free culture	90% viable cells <sup>(4)</sup>	(Mollamohammadi et al., 2009)
	90% KSR	No	hESC	Colony clumps	MEF feeder layer	8-53% survival <sup>(17)</sup>	(Lee et al., 2010)
		ROCK inhibitor	hESC	Colony clumps	MEF feeder layer	85-95% survival <sup>(6)</sup>	(Li et al., 2008b)
				Single cells	Feeder-free culture	53-65% <sup>(7)</sup>	(Li et al., 2009)
	90% (DMEM/F12 + 20% FBS)	Z-VAD-FMK	hESC	Adherent colonies	MEF feeder layer	18.7% <sup>(11)</sup>	(Heng et al., 2007)
		No				~98% (5 min) 20-30% (90 min) <sup>(12)</sup>	(Heng et al., 2005)
	60 % growth medium + 30%FBS	No	hESC	Adherent colonies (microcarriers)	MEF feeder layer and feeder-free culture	1.5-1.9 fold increase in recovery rate <sup>(13)</sup>	(Nie et al., 2009)
5% DMSO 5% HES	80% (DMEM/F12 + 20% KSR)	No	hESC	Colony clumps	MEF feeder layer	~80% recovery <sup>(9)</sup>	(T'joen et al., 2011)
10% DMSO + 0.2 mol/l Trehalose	90% KSR	No	hESC	Colony clumps	MEF feeder layer	37-48% recovery <sup>(10)</sup>	(Zhang et al., 2003)



10% DMSO+ 35 mM Trehalose	40% Growth medium + 50% FBS	No	hESCs	Adherent colonies	MEF feeder layer and feeder-free culture	25% viability increase in respect to DMSO alone <sup>(14)</sup>	(Ji et al., 2004)
7.5% DMSO 2.5% PEG	Growth medium	ROCK inhibitor + P53 inhibitor	hESCs	Single Cells	MEF feeder layer and feeder-free culture	80-90% survival <sup>(5)</sup>	(Xu et al., 2010b)
10% DMSO + another undisclosed CPA	Phosphate buffer	No	hESCs and iPSCs	Colony clumps	Human foreskin feeder layer	90-96% viability <sup>(15)</sup>	(Holm et al., 2010)
5% DMSO 10% EG	50%FBS and DMEM/ F12	No	hESCs	Colony clumps	MEF feeder layer	30% colony recovery <sup>(3)</sup>	(Ha et al., 2005)

Table 1. Cryoprotectant agents and freezing vehicles used for the cryopreservation of hPSCs using the slow-freezing rapid-thawing protocol. The conditions and recovery rates showed in the table correspond to the best condition tested in the referenced works. (DMSO: dimethyl sulfoxide; EG: ethylene glycol; PEG: polyethylene glycol; HES: Hydroxyethylstarch; FBS: fetal bovine serum; FCS: fetal calf serum; KSR: Knockout serum replacement; MEF: mouse embryonic fibroblasts). The recovery rates were determined using different tests: (1) % cell recovery determined by QUANTA Coulter Counter measurement of Calcein-PM+/7AAD-. (2) % viability determined with FDA/EB staining at different time points after thawing. (3) Number of colonies 10 days after plating. (4) Cell viability was determined counting the number of cells by the Trypan blue exclusion method immediately after thawing. (5) Cell viability was determined by FACS using propidium iodide staining immediately after thawing. (6) Number of colonies at day 5/total colonies replated. (7) Flow cytometry analysis of apoptosis using Annexin V and propidium iodide immediately after thawing. (8) Fold increase in the number of recovered cells determined using a Z2 Coulter Counter and Size analyzer 4 days after thawing. Fold increase in the number of colonies determined by microscopy. (9) Recovery rate was calculated as follows: the amount of Grade A+B colonies at day 7 post-thawing versus the amount of frozen Grade A+B colonies. (10) Number of colonies 7 days after thawing. (11) MTT assay to measure % survival rate 24 h post-thawing. (12) Viability determined by Trypan blue exclusion method of adherent colonies at different time points after thawing. (13) Recovery was calculated as the number of cells one week after thawing divided by the number of cells at the time of freezing. The recoveries of hPSCs frozen using microcarriers are normalized to the recoveries of hPSCs frozen as free colonies. (14) Cell viability was measured by MTT assay or Alamar Blue assay several days after thawing. (15) Viability or percentage of surviving cells was calculated as a ratio between live hPSCs after thawing and total number of initially frozen cells. Cells were counted using the Trypan blue exclusion method. (16) Recovery rates were estimated as the % of attached and undifferentiated clumps counted 7-8 days after-thawing respect to the initially frozen. (17) Viability was assessed counting the number of colonies stained for alkaline phosphatase.

A new cryopreservation formula containing 7.5% DMSO plus 2.5% polyethylene glycol was analyzed in another work (Xu et al., 2010b). This study resulted in slight but significant increase in the hESCs recovery determined by counting the number of cells or colonies in

feeder-independent or feeder-dependent culture respectively (Xu et al., 2010b). Recently, an alternative cryopreservation medium combining intracellular (5% DMSO) and extracellular (5% Hydroxyethylstarch) CPAs has been proven to be highly effective for the cryopreservation of small hESC clumps by the classical slow-freezing rapid-thawing method. These clumps are obtained by a combination of hESC colony detachment with Collagenase IV followed by 5 minutes dissociation using an undisclosed solution. This protocol is suitable for handling bulk amounts of hPSCs (T'joen et al., 2011).

Comparison of different freezing vehicles using DMSO as a cryoprotectant has also been studied for the cryopreservation of dissociated hESCs (Mollamohammadi et al., 2009). Three preservation media containing 10% DMSO plus: 90% fetal calf serum (FCS), 90% KSR or 90% hESCs medium containing 20% KSR and ROCK inhibitor were analyzed. The percentage of viable cells obtained by the Trypan blue exclusion method after thawing showed that cells were better preserved in the presence of 90% FCS as a vehicle (~90%). The other two freezing solutions caused lower survival rates (60-80%) (Mollamohammadi et al., 2009). Following a similar approach, Ha et al studied the impact of different FBS concentrations (5, 50 and 95%) in the vehicle freezing solution using a 5% DMSO as a CPA (Ha et al., 2005). A decrease in the survival rate is observed as the FBS concentration is reduced although no differences were found between 50 and 95%. Therefore, the authors established 50% of FBS as the optimal concentration to support hPSCs survival during the cryopreservation process (Ha et al., 2005).

### 3.3 Addition of molecules to enhance survival

One of the first molecules studied in the cryopreservation process to enhance cell survival was the caspase inhibitor Z-VAD-FMK (Heng et al., 2007). Results obtained in a previous work from the same group showing that apoptosis rather than necrosis was the responsible mechanism involved in the loss of viability during hESCs cryopreservation encouraged them to test a broad-spectrum irreversible inhibitor of caspase enzymes (Heng et al., 2006). Exposure to 100 mM Z-VAD-FMK in the freezing solution alone did not significantly enhance the post-thaw survival rate. However, when Z-VAD-FMK was added to the freezing solution as well as to the post-thawing solution a significant enhancement in the cell survival rate (~two fold) was observed. Nevertheless, the differentiation rates of cryopreserved hESCs were not reduced and therefore the culture recovery was not improved (Heng et al., 2007). Similarly, the addition of a specific Caspase-9 inhibitor to the post-thawing recovering medium failed to increase hESCs colony formation 4-5 days after thawing, although it did reduce Caspase 8 and 9 activity 2 h after cryopreservation (Xu et al., 2010a). These results suggested that Caspase activity was not the triggering mechanism contributing to the low hPSCs recovery after cryopreservation, but it could be a downstream effector.

A significant improvement in the cryopreservation field came up with the addition of a ROCK inhibitor. ROCK have been found to play a role in the regulation of multiple biological pathways such as apoptosis, cell cycle, differentiation, cell adhesion as well as gene expression (Amano et al., 1997; Hall, 1994; Ishizaki et al., 1997; Krawetz et al., 2009; Maekawa et al., 1999). Watanabe et al reported for the first time, that addition of the ROCK inhibitor Y-27632 improved the cloning efficiency of dissociated hESCs more than 25-fold when the cells were plated at low density (Watanabe et al., 2007). One year later, the same inhibitor was tested for the cryopreservation of hESCs. Li et al demonstrated that 10  $\mu$ M Y-27632 added to the post-thaw medium during 1 day increased hESCs survival when

cryopreserved as small clumps (Li et al., 2008b). In parallel our group reported that dissociated hESCs could be cryopreserved in the presence of ROCK inhibitor (Martin-Ibanez et al., 2008; Martin-Ibanez et al., 2009). The addition of Y-27632 to the freezing medium did not increase the formation of hESCs colonies compared to the control non treated cells although it increased cell survival. In contrast, the presence of ROCK inhibitor in the post-thawing recovery medium did increase the formation of hESCs colonies significantly (50-100 times). The addition of Y-27632 to both, the cryopreservation and the post-thawing medium was the condition tested contributing to the highest cell recovery after freezing.

Rock inhibitor addition	Type of cell and culture	Cell processing	Recovery rate (method of analysis)	Time of analysis	Reference
Freezing and post-thawing recovery media (1 day)	hESCs on human foresking feeders	Single cells	50-60% survival % survival after thawing analyzed by Trypan Blue exclusion method	Immediately after thawing	(Martin-Ibanez et al., 2008)
	hESCs and iPSCs in feeder-free culture	Single cells	60-80% viable cells % survival after thawing analyzed by Trypan blue exclusion method	Immediately after thawing	(Mollamohammadi et al., 2009)
	hESCs on MEF feeders and feeder-free culture	Single cells	80-90% survival % survival after thawing analyzed by propidium iodide staining	Immediately after thawing	(Xu et al., 2010a) (Xu et al., 2010b)
	iPSCs on MEF feeders	Single cells, clumps and adherent colonies	20-60% recovery depending on the type of culture % recovery after thawing by QUANTA Coulter Counter measurement of Calcein-PM+/7AAD-	Not stated	(Katkov et al., 2011)
Post-thawing recovery medium (1 day)	hESCs on MEF feeders	Colony clumps	85-95% survival Number of colonies at day 5/total colonies replated	5 days after thawing	(Li et al., 2008b)
	hESCs in feeder-free culture	Single cells	53-65% Flow cytometry analysis of apoptosis using Annexin V and propidium iodide	Immediately after thawing and 24 h after thawing	(Li et al., 2009)
Post-thawing recovery medium (4 days)	hESCs on MEF feeders and feeder-free culture	Single cells	7-8 fold increase in the number of recovered cells 4 days after thawing (Z2 Coulter Counter and Size analyzer)	4 days after thawing	(Claassen et al., 2009)
Post-thawing recovery medium (2 days)	iPSCs on MEF feeders	Single cells	7 fold increase in the number of colonies 48 h post-thawing	2 days after thawing	(Claassen et al., 2009)

Table 2. Overview of the ROCK inhibitor treatments tested to improve the recovery rates after cryopreservation of hPSCs. Survival rates showed in the table are obtained using the best condition tested in the work referenced.

Moreover, we described a complete avoidance of hESCs differentiation just after cryopreservation showing that most of the colonies expressed the undifferentiation markers: Oct-4, nanog, SSEA-4, TRA-1-81 and TRA-1-60. The addition of Y-27632 increased the growth rates to control levels, did not affect hESCs normal karyotype and kept their pluripotency (Martin-Ibanez et al., 2008). Similar results have been shown not only for hESCs but also for iPSCs in both feeder-associated and feeder-free conditions (Claassen et al., 2009; Katkov et al., 2011; Mollamohammadi et al., 2009). See table 2 for a sum up of all the ROCK inhibitor treatments used for cryopreservation of hPSCs.

ROCK inhibitors have also been used in combination with other molecules such as Caspase inhibitors, p53 inhibitors or Bax inhibitors added always to the post-thawing culture medium. Xu et al showed that none of the three combinations pan-Caspase inhibitors + Y-27632, Caspase 9 inhibitor + Y-27632 and Bax inhibitor + Y-27632 enhanced the protective effect of ROCK inhibitor alone for cryopreserved hESCs (Xu et al., 2010a). Only the treatment with a p53 inhibitor + Y27632 induced a cell recovery similar to that of ROCK inhibitor. However, treatment with p53 alone did not account for an increase in cell survival (Xu et al., 2010a). Similar results were obtained by the same group in another report where they observed an enhancement of hESCs recovery when cryopreserved in 10% DMSO or 7.5% DMSO + 2.5% polyethylene glycol and treated with p53 inhibitor + Y-27632 in the post-thawing medium (Xu et al., 2010b).

Although most of the works studying the effect of ROCK inhibitor during cryopreservation did not address the mechanism of action of this molecule, at least two of them showed some interesting results (Li et al., 2009; Xu et al., 2010a). Both of them reported a reduction in hESCs apoptosis and/or Caspase activity one day after cryopreservation driven by Y-27632. This is in agreement with the previous report of Watanabe et al who pointed to an antiapoptotic role of this ROCK inhibitor (Watanabe et al., 2007). In addition, Li et al demonstrated that Y-27632 treatment increased the adherent properties of cryopreserved hESCs favoring cell aggregate formation and adhesion to the substrate. This effect, in turn, prevented anoikis and enhanced hESCs survival (Li et al., 2009; Mollamohammadi et al., 2009).

### 3.4 Cryopreservation of adherent versus suspension hPSC colonies

In view of the poor survival rates obtained after cryopreservation of hPSCs in suspension using the slow-cooling rapid thawing method, some authors decided to test cryopreservation of adherent cells. This decision was based on previous studies done with certain cell types difficult to preserve. For example, hepatocytes cryopreserved in alginate gels display a higher viability and lower apoptotic activity than hepatocytes cryopreserved in suspension (Mahler et al., 2003). Similarly, hepatocytes sandwiched between two layers of collagen provide enhanced viability and protein secretion compared with cells preserved in solution (Birraux et al., 2002; Koebe et al., 1990; Koebe et al., 1999). Taking these results as a proof of principle, hESCs were successfully cryopreserved as adherent colonies in 24 well plates in medium containing 10% DMSO + 30% FBS by Ji et al (Ji et al., 2004). This approach demonstrated that hESCs frozen as adherent colonies were five times more viable than clumps of colonies frozen in suspension. In addition, encapsulation of hESCs colonies inside Matrigel™ for 1 or 2 days increased viability significantly respect to unencapsulated adherent frozen colonies or colonies encapsulated for just 1 h. The percentage of adherent hESC colonies recovered 1 to 2 weeks after cryopreservation was about 80-90% and almost no differentiation was detected. In

contrast, less than 2% of hESC colonies attached when frozen in suspension. A recent work by Katkov et al reported a refinement of the technique cryopreserving adherent iPSC colonies in the presence of ethylene glycol as a cryoprotectant and using a six-step programmed protocol (Katkov et al., 2011). Preservation of iPSCs under these conditions induced a six-fold increase in cell recovery after thawing respect the standard cryopreservation of cell clumps by the slow-freezing rapid thawing method (Katkov et al., 2011). Two mechanisms are postulated to explain the increased viability obtained preserving hESCs as adherent colonies. The first is that hESC colonies do not have to settle to the surface and attach. This is a decisive process for the survival of hPSC colonies frozen in suspension that is rarely achieved due to the massive cell death or cell damage experienced within the colony during cryopreservation. Second, the maintenance of a continuous extracellular matrix signaling may also play a role in the enhanced viability and reduced differentiation of hESCs cryopreserved in an adherent state (Ji et al., 2004). The disadvantage of this technique is that large scale storage is not feasible because hPSCs attached to plates cannot be stored at high density. In addition, culture plates are unable to be sealed like cryovials, increasing the risk of sample cross-contamination during storage in liquid nitrogen. However, methodologies such as preservation on microcarriers might provide the advantages of freezing adherent cells at higher densities that are not possible on flat surfaces. This is what has been described by Nie et al, who used Cytodex 3 microcarriers to cryopreserve adherent hESCs (Nie et al., 2009). These microcarriers consisted of a thin layer of denatured collagen covalently coupled to a matrix of cross-linked dextran. They were modified with Matrigel™ or irradiated MEF to enhance the adhesion of hESC colonies. In this work it was first demonstrated that hESCs colonies were effectively expanded in a pluripotent, undifferentiated state on both types of microcarriers (Matrigel™ and MEF coated). Then cryopreservation utilizing this system was compared to standard freezing of hESC colonies in suspension. hESCs-microcarriers were suspended in freezing medium consisting in 10%DMSO and 30%FBS at a cell density of  $1 \times 10^6$  cells/ml on 10 cm<sup>2</sup> microcarriers. The suspension was transferred to cryovials, frozen inside a freezing container at a cooling rate of -1°C/min and moved into liquid nitrogen. Seven days after thawing viability was assessed by counting the number of cells. This number was compared to that of the conventional hESCs slow freezing method. Cryopreservation on microcarriers resulted in 1.7 times the recovery of hESCs frozen in free suspension (Nie et al., 2009). Although the enhancement of cell recovery is not very promising, further optimization of this methodology holds a great potential for future larger-scale cryopreservation.

### 3.5 Cryopreservation of dissociated single hPSCs versus clumps of colonies

hPSCs are colony-forming social cells that present a high vulnerability to apoptosis upon cellular detachment and dissociation (Amit et al., 2000; Watanabe et al., 2007). These characteristics could explain why most of the cryopreservation protocols rely on hPSCs small clumps to improve survival rates (Heng et al., 2006; Reubinoff et al., 2001; Richards et al., 2004; Zhou et al., 2004). However, the cryopreservation of clumps presents some associated problems such as limitations on cryoprotectant exposure inside the clump. In this sense, T'Joen et al demonstrated that the application of a cell dissociation solution before freezing, thereby creating a mixed population of very small hESC clumps and single cells, increased the recovery rate after cryopreservation (T'joen et al., 2011). In addition, the use of hPSC colony clumps also prevents a good estimation of freezing-thawing efficiency, as precise cell numbers cannot be estimated. Therefore, development of cryopreservation protocols for dissociated hPSCs is a pre-requisite for the widespread use of these cells in basic or clinical research.

Most of the studies carried out so far for the cryopreservation of dissociated hPSCs involved the usage of ROCK inhibitors (usually 10 $\mu$ M of Y-27632), since in its absence very few or none colonies are obtained. This inhibitor has been reported to significantly increase the survival rate of frozen/thawed single hESC as well as iPSCs (Claassen et al., 2009; Li et al., 2009; Martin-Ibanez et al., 2008; Mollamohammadi et al., 2009; Xu et al., 2010a; Xu et al., 2010b). Recent studies have demonstrated that Y-27632 increased not only the survival rate but also the adhesion of frozen-thawed dissociated single hPSCs in the presence and absence of feeder cells (Claassen et al., 2009; Katkov et al., 2011; Li et al., 2009; Martin-Ibanez et al., 2008; Mollamohammadi et al., 2009; Xu et al., 2010a; Xu et al., 2010b). In fact, Li et al. proposed that Y-27632 does not block apoptotic pathways, but rather prevents hPSCs from sensing their external environment, giving them time to make important cell-cell interactions and thus allowing them to escape anoikis (Krawetz et al., 2009; Li et al., 2009). Moreover, Mollamohammadi et al. showed by RT-PCR analysis that the expression of integrin chains  $\alpha$ V,  $\alpha$ 6 and  $\beta$ 1 increased significantly in the presence of ROCK inhibitor (Mollamohammadi et al., 2009). They proposed that this increase in integrins expression may account for the maintenance of an undifferentiated state and an increase in cell adhesion of hESCs and iPSCs to the substrate allowing better cloning efficiency (Mollamohammadi et al., 2009).

The usage of ROCK inhibitors for continuous treatments has not induced any adverse effects on hPSCs pluripotency or chromosomal stability, even after substantial number of passages (Mollamohammadi et al., 2009; Watanabe et al., 2007). ROCK inhibitors such as Y-27632 or Fasudil are already used clinically in cardiovascular therapies (Hu & Lee, 2005), suggesting that they are safe for the treatment of hPSCs. Although the exact mechanism of action of ROCK inhibitors is, at the moment, unknown and a lot of cross talks between signaling pathways occur, the usage of this compound opens a new field of study to improve hPSCs cryopreservation and culture protocols.

### 3.6 Controlled-rate cryopreservation

The cooling rate is one of the cryobiological variables associated with damage during slow-cooling (Figure 2). When the cooling process is rapid, intracellular ice crystals form before complete cellular dehydration has occurred. These ice crystals disrupt cellular organelles and membranes and lead to cell death during the recovery (thawing) process. On the other hand, when the cooling process is slow, free intracellular water is osmotically pulled from the cells resulting in complete cellular dehydration and shrinkage. This can also cause cellular death but there is little agreement on the mechanisms involved. However, when the cooling rate is slow enough to prevent intracellular ice formation, but fast enough to avoid serious dehydration effects, cells may be able to survive the freezing and thawing process. This survival zone or window is readily observed in many bacteria and other prokaryotes, but for most eukaryotic cells it is nonexistent or very difficult to find without using cryoprotectants. These agents have little effect on the damage caused by fast freezing (intracellular ice crystal formation), but rather prevent or lessen the damage caused by slow freezing (dehydration and shrinkage) (Figure 2) (Mazur, 1984). Thus, a tight control of the cooling rate is crucial to reduce cellular damage during cryopreservation, even in the presence of CPAs. This is achieved by the usage of programmable freezers. These devices, although expensive and not always available, are technically more reliable and reproducible. Several works have studied the relevance of programmable freezers for the cryopreservation of hPSCs. Ware et al. reported survival rates of 60-70% with no apparent increase in differentiation using DMSO as a cryoprotectant, a control rate freezing device and straws as containers (Ware et al., 2005). The

results of this study identified three critical factors for successful hESCs freezing: ice crystal seed at some point above the temperature of spontaneous intracellular ice formation (between  $-7^{\circ}\text{C}$  and  $-12^{\circ}\text{C}$ ), an appropriate freezing rate (between  $-0,3^{\circ}\text{C}$  and  $-1,8^{\circ}\text{C}/\text{min}$ ) and rapid thawing (at  $25-37^{\circ}\text{C}$ ) (Ware et al., 2005). Another study optimizing the same critical factors described an improved protocol consisting in: cooling the sample from  $0^{\circ}\text{C}$  to  $-35^{\circ}\text{C}$  at a cooling rate of  $-0.5^{\circ}\text{C}/\text{min}$ , seeding at  $-10^{\circ}\text{C}$  before being plunged immediately into the liquid nitrogen and rapid thawing. Under these conditions a survival rate of 80% was obtained (Yang et al., 2006). A successful usage of programmable freezing for the cryopreservation of adherent iPSCs has also been recently described (Katkov et al., 2011). The authors developed a six step programmed protocol including : 1)  $-1^{\circ}\text{C}/\text{min}$  from  $0^{\circ}\text{C}$  (addition of CPA on ice) to  $-10^{\circ}\text{C}$ ; 2) hold for 30 min at  $-10^{\circ}\text{C}$ ; 3)  $-3^{\circ}\text{C}/\text{min}$  to  $-40^{\circ}\text{C}$ ; 4)  $-1^{\circ}\text{C}/\text{min}$  to  $-60^{\circ}\text{C}$ ; 5)  $-0.33^{\circ}\text{C}/\text{min}$  to  $-80^{\circ}\text{C}$  and 6) hold at  $-80^{\circ}\text{C}$  for 5 min and then transfer to liquid nitrogen. Adherent iPSC colonies cryopreserved using ethylene glycol as a CPA under these conditions showed a 63% recovery, which represents a 6 fold increase respect the preservation without a programmable freezer using DMSO (Katkov et al., 2011).

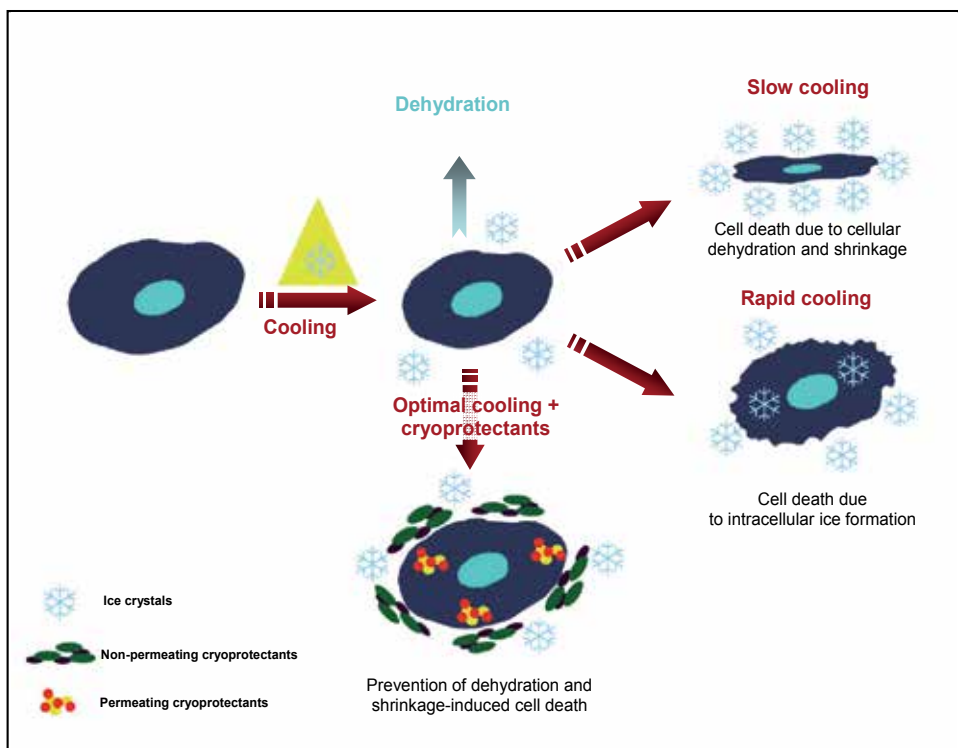

Fig. 2. Effects occurring during the cryopreservation of cells at different cooling rates. When the cooling process starts, ice crystals formation is induced and free intracellular water is osmotically pulled from the cells. If the cooling process is slow this effect lead to cellular cell death by dehydration and shrinkage. In contrast, if the cooling process is rapid, intracellular ice crystals form before complete cellular dehydration has occurred. These crystals induce cell death by cellular organelles and membrane disruption during the thawing process. An optimal cooling rate together with the usage of cryoprotectants in the freezing media avoids dehydration effects and intracellular ice formation allowing cell survival after thawing.

A recent report made an interesting comparison of three methods of cryopreservation of hESC clumps including: conventional slow freezing-rapid thawing using cryovials, vitrification and programmable cryopreservation in plastic straws (Li et al., 2010b). Assessing the efficiency of cryopreservation by counting the number of attached undifferentiated colonies 1-2 days and 7-8 days after thawing they reached the conclusion that conventional cryopreservation may not be appropriated for hESCs preservation since few colonies attached and most of them were differentiated. The usage of a programmable freezer increased significantly the cryopreservation efficiency (~50% colony recovery respect to ~5% of conventional freezing), although it was not better than the high efficiency obtained by vitrification (80-90% colony recovery). Both methodologies maintain unaffected the pluripotency and normal karyotype of the cells (Li et al., 2010b). Another comparative study published at the same time reported lower survival rates after programmable cryopreservation of hESC clumps (10-20% survival colonies), although they were significantly higher than the ones obtained after conventional slow-freezing (4-8%) (Lee et al., 2010). In this study the best cryopreservation condition was obtained using a stepwise transfer method for hESC clumps, which consisted in using a series of solutions with increasing serum replacement and DMSO concentrations to achieve a stepwise equilibration before freezing. The same inverse process was performed after thawing in order to gradually rehydrate the cells. The combination of stepwise methods with programmable freezers yielded survival rates of 30-50% with low numbers of differentiated cells (Lee et al., 2010).

### 3.7 Cryopreservation in xeno-free conditions

Clinical application of hPSCs would need hESC and iPSC lines derived, cultured, differentiated and cryopreserved in xeno-free conditions following good manufacturing practice (GMP) regulations. Several attempts to improve hPSCs culture conditions have been reported. These advances include: the derivation of clinical grade hESC and iPSC lines, the use of conditioned media together with Matrigel™ as an attachment substrate for hPSCs culture and the derivation and propagation of hESC lines on human feeder layers in xeno-free culture media (Amit et al., 2004; Hovatta et al., 2003; Rajala et al., 2007; Rajala et al., 2010; Richards et al., 2002; Richards et al., 2003; Skottman et al., 2006; Unger et al., 2008). Some approaches have also been done in the cryopreservation field towards the development of xeno-free effective cryopreservation protocols. The first one was an optimization of the established vitrification method previously described by Reubinoff et al (Reubinoff et al., 2001; Richards et al., 2004). In this new method they reported the successful vitrification of hESCs in sealed closed straws, their storage in the vapor phase of liquid nitrogen and the substitution of FCS with human serum albumin as the major protein source in the cryoprotectant solution. This refinement of the technique allowed the removal of animal components from the cryopreservation medium, therefore lowering the risk of cross-transfer of viruses and other pathogens to the hESCs. Moreover, sealing the straws the authors also prevented contact with potentially contaminated liquid nitrogen during cooling and storage. The efficiency of hESCs preservation was similar to the original vitrification protocol (Richards et al., 2004).

An effective serum and xeno-free chemically defined freezing procedure for hESCs and iPSCs has been recently developed (Holm et al., 2010). This protocol describes the usage of a commercially available freezing and post-thaw washing solution that presents the



advantage of being chemically defined, sterile and batch tested. The cryopreservation solution named STEM-CELLBANKER™ contains 10% DMSO, glucose and a high molecular weight polymer (undisclosed) used as a second cryoprotectant, all dissolved in phosphate-buffered saline. hPSCs are preserved using this solution in cryovials and the slow-cooling rapid-thawing method, without any programmed freezer. After thawing, cells are recovered in the washing solution named CELLOTION™ containing NaCl, centrifuged to eliminate cryoprotectants and plated down on a feeder layer of human mitotically inactivated fibroblasts. Post-thaw recovery was substantially increased without any detrimental impact on proliferation or differentiation (Holm et al., 2010). Similar cryopreservation yields were obtained for both hESCs preserved as clumps and iPSCs preserved as single cells without ROCK inhibitor treatment. Therefore, this is a simple and efficient system that enables the cryopreservation of large quantities of hPSCs in a chemically defined medium that is clinical grade compatible (Holm et al., 2010). Employing a similar protocol but using a home-made cryopreservation solution containing 10% DMSO and 90% KSR, Li et al reported the preservation of single hESCs in serum and feeder-free conditions in the presence of ROCK inhibitor during the first day after thawing (Li et al., 2009).

#### 4. Conclusion

Understanding the mechanisms involved in the high vulnerability of hPSCs to the cryopreservation process is essential to develop efficient protocols for cryopreservation. Most of the research being undertaken over the last years is still empirical and few advances have been achieved in the identification of the pathways involved in the enhancement of cell survival induced by different factors, cryoprotectants or preservation systems. However, from the results obtained in these studies it is becoming increasingly clear that cell-cell adhesion and/or paracrine signaling between hPSCs are essential for survival and control of their undifferentiated state (Amit et al., 2000; Reubinoff et al., 2000; Thomson et al., 1998). Gap junctions and cell adhesion molecules are highly expressed in hESCs and have been implicated in these processes (De et al., 2002; Richards et al., 2004; Sathananthan et al., 2002; Wong et al., 2004; Wong et al., 2008). Therefore, disruption of these structures during cryopreservation due to ice crystal formation outside the cells may induce anoikis contributing to the poor recovery of hPSCs after slow cooling. However, a better understanding of this process together with a systematic study of the critical cryobiological variables is still needed to improve the already existing cryopreservation protocols. Further advances in the field would also require the development of reliable and standardized assays to measure not only immediate post-thaw recovery but also the ability of single cells or clumps to re-attach, proliferate and maintain pluripotency. Moreover, it is necessary to establish the n-points at which these assays should be applied, in order to allow direct quantitative comparisons between different cryopreservation methods that are not feasible at the moment. Thus, all present and future investigations would likely provide a reproducible effective and efficient cryopreservation protocol for hPSCs large-scale storage that will fulfill GMP requirements, permitting the widespread use of hPSCs in basic and/or clinical research.

#### 5. Acknowledgements

Our group is supported by grants from the Ministerio de Ciencia e Innovación (SAF2009-07774 and PLE2009-0089), Instituto de Salud Carlos III, Ministerio de Ciencia e Innovación

[CIBERNED and RETICS (RD06/0010/0006; Red de Terapia Celular)] and Generalitat de Catalunya (2009SGR-00326), Spain. The Cell Therapy Program is supported by the Centre of Regenerative Medicine in Barcelona (CMRB; Promt-0901), Generalitat de Catalunya, Spain.

## 6. References

- Adler, S., Pellizzer, C., Paparella, M., Hartung, T., & Bremer, S. (2006). The effects of solvents on embryonic stem cell differentiation. *Toxicol. In Vitro*, Vol. 20, No. 3, pp. (265-271)
- Amano, M., Chihara, K., Kimura, K., Fukata, Y., Nakamura, N., Matsuura, Y., & Kaibuchi, K. (1997). Formation of actin stress fibers and focal adhesions enhanced by Rho-kinase. *Science*, Vol. 275, No. 5304, pp. (1308-1311)
- Amit, M., Carpenter, M.K., Inokuma, M.S., Chiu, C.P., Harris, C.P., Waknitz, M.A., Itskovitz-Eldor, J., & Thomson, J.A. (2000). Clonally derived human embryonic stem cell lines maintain pluripotency and proliferative potential for prolonged periods of culture. *Dev. Biol.*, Vol. 227, No. 2, pp. (271-278)
- Amit, M., Shariki, C., Margulets, V., & Itskovitz-Eldor, J. (2004). Feeder layer- and serum-free culture of human embryonic stem cells. *Biol. Reprod.*, Vol. 70, No. 3, pp. (837-845)
- Apostolou, E. & Hochedlinger, K. (2011). Stem cells: iPS cells under attack. *Nature*, Vol. 474, No. 7350, pp. (165-166)
- Batthey, J.F. (2007). Stem cells: current challenges and future promise. *Dev. Dyn.*, Vol. 236, No. 12, pp. (3193-3198)
- Baust, J.G., Gao, D., & Baust, J.M. (2009). Cryopreservation: An emerging paradigm change. *Organogenesis.*, Vol. 5, No. 3, pp. (90-96)
- Baust, J.M., Vogel, M.J., Van, B.R., & Baust, J.G. (2001). A molecular basis of cryopreservation failure and its modulation to improve cell survival. *Cell Transplant.*, Vol. 10, No. 7, pp. (561-571)
- Berz, D., McCormack, E.M., Winer, E.S., Colvin, G.A., & Quesenberry, P.J. (2007). Cryopreservation of hematopoietic stem cells. *Am. J. Hematol.*, Vol. 82, No. 6, pp. (463-472)
- Birraux, J., Genin, B., Matthey-Doret, D., Mage, R., Morel, P., & Le, C.C. (2002). Hepatocyte cryopreservation in a three-dimensional structure. *Transplant. Proc.*, Vol. 34, No. 3, pp. (764-767)
- Bosma, G.C., Custer, R.P., & Bosma, M.J. (1983). A severe combined immunodeficiency mutation in the mouse. *Nature*, Vol. 301, No. 5900, pp. (527-530)
- Carpenter, M.K., Rosler, E., & Rao, M.S. (2003). Characterization and differentiation of human embryonic stem cells. *Cloning Stem Cells*, Vol. 5, No. 1, pp. (79-88)
- Chambers, I., Colby, D., Robertson, M., Nichols, J., Lee, S., Tweedie, S., & Smith, A. (2003). Functional expression cloning of Nanog, a pluripotency sustaining factor in embryonic stem cells. *Cell*, Vol. 113, No. 5, pp. (643-655)
- Chin, M.H., Mason, M.J., Xie, W., Volinia, S., Singer, M., Peterson, C., Ambartsumyan, G., Aimiwu, O., Richter, L., Zhang, J., Khvorostov, I., Ott, V., Grunstein, M., Lavon, N., Benvenisty, N., Croce, C.M., Clark, A.T., Baxter, T., Pyle, A.D., Teitell, M.A., Pelegri, M., Plath, K., & Lowry, W.E. (2009). Induced pluripotent stem cells and embryonic stem cells are distinguished by gene expression signatures. *Cell Stem Cell*, Vol. 5, No. 1, pp. (111-123)

- Claassen, D.A., Desler, M.M., & Rizzino, A. (2009). ROCK inhibition enhances the recovery and growth of cryopreserved human embryonic stem cells and human induced pluripotent stem cells. *Mol. Reprod. Dev.*, Vol. 76, No. 8, pp. (722-732)
- Condic, M.L. & Rao, M. (2008). Regulatory issues for personalized pluripotent cells. *Stem Cells*, Vol. 26, No. 11, pp. (2753-2758)
- Crowe, J.H., Crowe, L.M., Oliver, A.E., Tsvetkova, N., Wolkers, W., & Tablin, F. (2001). The trehalose myth revisited: introduction to a symposium on stabilization of cells in the dry state. *Cryobiology*, Vol. 43, No. 2, pp. (89-105)
- De, M.A., Vega, V.L., & Contreras, J.E. (2002). Gap junctions, homeostasis, and injury. *J. Cell Physiol*, Vol. 191, No. 3, pp. (269-282)
- Draper, J.S., Smith, K., Gokhale, P., Moore, H.D., Maltby, E., Johnson, J., Meisner, L., Zwaka, T.P., Thomson, J.A., & Andrews, P.W. (2004). Recurrent gain of chromosomes 17q and 12 in cultured human embryonic stem cells. *Nat. Biotechnol.*, Vol. 22, No. 1, pp. (53-54)
- Erdag, G., Eroglu, A., Morgan, J., & Toner, M. (2002). Cryopreservation of fetal skin is improved by extracellular trehalose. *Cryobiology*, Vol. 44, No. 3, pp. (218-228)
- Evans, M.J. & Kaufman, M.H. (1981). Establishment in culture of pluripotential cells from mouse embryos. *Nature*, Vol. 292, No. 5819, pp. (154-156)
- Fu, T., Guo, D., Huang, X., O'Gorman, M.R., Huang, L., Crawford, S.E., & Soriano, H.E. (2001). Apoptosis occurs in isolated and banked primary mouse hepatocytes. *Cell Transplant.*, Vol. 10, No. 1, pp. (59-66)
- Fujikawa, S. (1980). Freeze-fracture and etching studies on membrane damage on human erythrocytes caused by formation of intracellular ice. *Cryobiology*, Vol. 17, No. 4, pp. (351-362)
- Gao, D.Y., Chang, Q., Liu, C., Farris, K., Harvey, K., McGann, L.E., English, D., Jansen, J., & Critser, J.K. (1998). Fundamental cryobiology of human hematopoietic progenitor cells. I: Osmotic characteristics and volume distribution. *Cryobiology*, Vol. 36, No. 1, pp. (40-48)
- Gao, D.Y., Liu, J., Liu, C., McGann, L.E., Watson, P.F., Kleinhans, F.W., Mazur, P., Critser, E.S., & Critser, J.K. (1995). Prevention of osmotic injury to human spermatozoa during addition and removal of glycerol. *Hum. Reprod.*, Vol. 10, No. 5, pp. (1109-1122)
- Grout, B., Morris, J., & McLellan, M. (1990). Cryopreservation and the maintenance of cell lines. *Trends Biotechnol.*, Vol. 8, No. 10, pp. (293-297)
- Ha, S.Y., Jee, B.C., Suh, C.S., Kim, H.S., Oh, S.K., Kim, S.H., & Moon, S.Y. (2005). Cryopreservation of human embryonic stem cells without the use of a programmable freezer. *Hum. Reprod.*, Vol. 20, No. 7, pp. (1779-1785)
- Hall, A. (1994). Small GTP-binding proteins and the regulation of the actin cytoskeleton. *Annu. Rev. Cell Biol.*, Vol. 10, pp. (31-54)
- Heins, N., Englund, M.C., Sjoblom, C., Dahl, U., Tonning, A., Bergh, C., Lindahl, A., Hanson, C., & Semb, H. (2004). Derivation, characterization, and differentiation of human embryonic stem cells. *Stem Cells*, Vol. 22, No. 3, pp. (367-376)
- Heng, B.C., Bested, S.M., Chan, S.H., & Cao, T. (2005). A proposed design for the cryopreservation of intact and adherent human embryonic stem cell colonies. *In Vitro Cell Dev. Biol. Anim*, Vol. 41, No. 3-4, pp. (77-79)

- Heng, B.C., Clement, M.V., & Cao, T. (2007). Caspase inhibitor Z-VAD-FMK enhances the freeze-thaw survival rate of human embryonic stem cells. *Biosci. Rep.*, Vol. 27, No. 4-5, pp. (257-264)
- Heng, B.C., Ye, C.P., Liu, H., Toh, W.S., Rufaihah, A.J., Yang, Z., Bay, B.H., Ge, Z., Ouyang, H.W., Lee, E.H., & Cao, T. (2006). Loss of viability during freeze-thaw of intact and adherent human embryonic stem cells with conventional slow-cooling protocols is predominantly due to apoptosis rather than cellular necrosis. *J. Biomed. Sci.*, Vol. 13, No. 3, pp. (433-445)
- Holm, F., Strom, S., Inzunza, J., Baker, D., Stromberg, A.M., Rozell, B., Feki, A., Bergstrom, R., & Hovatta, O. (2010). An effective serum- and xeno-free chemically defined freezing procedure for human embryonic and induced pluripotent stem cells. *Hum. Reprod.*, Vol. 25, No. 5, pp. (1271-1279)
- Hovatta, O., Mikkola, M., Gertow, K., Stromberg, A.M., Inzunza, J., Hreinsson, J., Rozell, B., Blennow, E., Andang, M., & Ahrlund-Richter, L. (2003). A culture system using human foreskin fibroblasts as feeder cells allows production of human embryonic stem cells. *Hum. Reprod.*, Vol. 18, No. 7, pp. (1404-1409)
- Hu, E. & Lee, D. (2005). Rho kinase as potential therapeutic target for cardiovascular diseases: opportunities and challenges. *Expert. Opin. Ther. Targets.*, Vol. 9, No. 4, pp. (715-736)
- Hubel, A. (1997). Parameters of cell freezing: implications for the cryopreservation of stem cells. *Transfus. Med. Rev.*, Vol. 11, No. 3, pp. (224-233)
- Hunt, C.J. (2011). Cryopreservation of Human Stem Cells for Clinical Application: A Review. *Transfus. Med. Hemother.*, Vol. 38, No. 2, pp. (107-123)
- Hunt, C.J. & Timmons, P.M. (2007). Cryopreservation of human embryonic stem cell lines. *Methods Mol. Biol.*, Vol. 368, pp. (261-270)
- Ishizaki, T., Naito, M., Fujisawa, K., Maekawa, M., Watanabe, N., Saito, Y., & Narumiya, S. (1997). p160ROCK, a Rho-associated coiled-coil forming protein kinase, works downstream of Rho and induces focal adhesions. *FEBS Lett.*, Vol. 404, No. 2-3, pp. (118-124)
- Ji, L., de Pablo, J.J., & Palecek, S.P. (2004). Cryopreservation of adherent human embryonic stem cells. *Biotechnol. Bioeng.*, Vol. 88, No. 3, pp. (299-312)
- Karlsson, J.O. (2002). Cryopreservation: freezing and vitrification. *Science*, Vol. 296, No. 5568, pp. (655-656)
- Karlsson, J.O. & Toner, M. (1996). Long-term storage of tissues by cryopreservation: critical issues. *Biomaterials*, Vol. 17, No. 3, pp. (243-256)
- Katkov, I.I., Kan, N.G., Cimadamore, F., Nelson, B., Snyder, E.Y., & Terskikh, A.V. (2011). DMSO-Free Programmed Cryopreservation of Fully Dissociated and Adherent Human Induced Pluripotent Stem Cells. *Stem Cells Int.*, Vol. 2011, pp. (981606-)
- Katkov, I.I., Kim, M.S., Bajpai, R., Altman, Y.S., Mercola, M., Loring, J.F., Terskikh, A.V., Snyder, E.Y., & Levine, F. (2006). Cryopreservation by slow cooling with DMSO diminished production of Oct-4 pluripotency marker in human embryonic stem cells. *Cryobiology*, Vol. 53, No. 2, pp. (194-205)
- Kiskinis, E. & Eggan, K. (2010). Progress toward the clinical application of patient-specific pluripotent stem cells. *J. Clin. Invest*, Vol. 120, No. 1, pp. (51-59)
- Klebe, R.J. & Mancuso, M.G. (1983). Identification of new cryoprotective agents for cultured mammalian cells. *In Vitro*, Vol. 19, No. 3 Pt 1, pp. (167-170)

- Klimanskaya, I., Chung, Y., Becker, S., Lu, S.J., & Lanza, R. (2006). Human embryonic stem cell lines derived from single blastomeres. *Nature*, Vol. 444, No. 7118, pp. (481-485)
- Koebe, H.G., Dunn, J.C., Toner, M., Sterling, L.M., Hubel, A., Cravalho, E.G., Yarmush, M.L., & Tompkins, R.G. (1990). A new approach to the cryopreservation of hepatocytes in a sandwich culture configuration. *Cryobiology*, Vol. 27, No. 5, pp. (576-584)
- Koebe, H.G., Muhling, B., Deglmann, C.J., & Schildberg, F.W. (1999). Cryopreserved porcine hepatocyte cultures. *Chem. Biol. Interact.*, Vol. 121, No. 1, pp. (99-115)
- Krawetz, R.J., Li, X., & Rancourt, D.E. (2009). Human embryonic stem cells: caught between a ROCK inhibitor and a hard place. *Bioessays*, Vol. 31, No. 3, pp. (336-343)
- Lee, J.Y., Lee, J.E., Kim, D.K., Yoon, T.K., Chung, H.M., & Lee, D.R. (2010). High concentration of synthetic serum, stepwise equilibration and slow cooling as an efficient technique for large-scale cryopreservation of human embryonic stem cells. *Fertil. Steril.*, Vol. 93, No. 3, pp. (976-985)
- Li, T., Mai, Q., Gao, J., & Zhou, C. (2010a). Cryopreservation of human embryonic stem cells with a new bulk vitrification method. *Biol. Reprod.*, Vol. 82, No. 5, pp. (848-853)
- Li, T., Zhou, C., Liu, C., Mai, Q., & Zhuang, G. (2008a). Bulk vitrification of human embryonic stem cells. *Hum. Reprod.*, Vol. 23, No. 2, pp. (358-364)
- Li, X., Krawetz, R., Liu, S., Meng, G., & Rancourt, D.E. (2009). ROCK inhibitor improves survival of cryopreserved serum/feeder-free single human embryonic stem cells. *Hum. Reprod.*, Vol. 24, No. 3, pp. (580-589)
- Li, X., Meng, G., Krawetz, R., Liu, S., & Rancourt, D.E. (2008b). The ROCK inhibitor Y-27632 enhances the survival rate of human embryonic stem cells following cryopreservation. *Stem Cells Dev.*, Vol. 17, No. 6, pp. (1079-1085)
- Li, Y., Tan, J.C., & Li, L.S. (2010b). Comparison of three methods for cryopreservation of human embryonic stem cells. *Fertil. Steril.*, Vol. 93, No. 3, pp. (999-1005)
- Lin, G., Ouyang, Q., Zhou, X., Gu, Y., Yuan, D., Li, W., Liu, G., Liu, T., & Lu, G. (2007). A highly homozygous and parthenogenetic human embryonic stem cell line derived from a one-pronuclear oocyte following in vitro fertilization procedure. *Cell Res.*, Vol. 17, No. 12, pp. (999-1007)
- Maekawa, M., Ishizaki, T., Boku, S., Watanabe, N., Fujita, A., Iwamatsu, A., Obinata, T., Ohashi, K., Mizuno, K., & Narumiya, S. (1999). Signaling from Rho to the actin cytoskeleton through protein kinases ROCK and LIM-kinase. *Science*, Vol. 285, No. 5429, pp. (895-898)
- Maherali, N., Sridharan, R., Xie, W., Utikal, J., Eminli, S., Arnold, K., Stadtfeld, M., Yachechko, R., Tchieu, J., Jaenisch, R., Plath, K., & Hochedlinger, K. (2007). Directly reprogrammed fibroblasts show global epigenetic remodeling and widespread tissue contribution. *Cell Stem Cell*, Vol. 1, No. 1, pp. (55-70)
- Mahler, S., Desille, M., Fremond, B., Chesne, C., Guillouzo, A., Champion, J.P., & Clement, B. (2003). Hypothermic storage and cryopreservation of hepatocytes: the protective effect of alginate gel against cell damages. *Cell Transplant.*, Vol. 12, No. 6, pp. (579-592)
- Mai, Q., Yu, Y., Li, T., Wang, L., Chen, M.J., Huang, S.Z., Zhou, C., & Zhou, Q. (2007). Derivation of human embryonic stem cell lines from parthenogenetic blastocysts. *Cell Res.*, Vol. 17, No. 12, pp. (1008-1019)

- Martin, G.R. (1981). Isolation of a pluripotent cell line from early mouse embryos cultured in medium conditioned by teratocarcinoma stem cells. *Proc. Natl. Acad. Sci. U. S. A.*, Vol. 78, No. 12, pp. (7634-7638)
- Martin-Ibanez, R., Stromberg, A.M., Hovatta, O., & Canals, J.M. (2009). Cryopreservation of dissociated human embryonic stem cells in the presence of ROCK inhibitor. *Curr. Protoc. Stem Cell Biol.*, Vol. Chapter 1, pp. (Unit-
- Martin-Ibanez, R., Unger, C., Stromberg, A., Baker, D., Canals, J.M., & Hovatta, O. (2008). Novel cryopreservation method for dissociated human embryonic stem cells in the presence of a ROCK inhibitor. *Hum. Reprod.*, Vol. 23, No. 12, pp. (2744-2754)
- Matsumura, K., Bae, J.Y., & Hyon, S.H. (2010). Polyampholytes as cryoprotective agents for mammalian cell cryopreservation. *Cell Transplant.*, Vol. 19, No. 6, pp. (691-699)
- Mazur, P. (1984). Freezing of living cells: mechanisms and implications. *Am. J. Physiol.*, Vol. 247, No. 3 Pt 1, pp. (C125-C142)
- Mazur, P. & Cole, K.W. (1989). Roles of unfrozen fraction, salt concentration, and changes in cell volume in the survival of frozen human erythrocytes. *Cryobiology*, Vol. 26, No. 1, pp. (1-29)
- Mazur, P., Leibo, S.P., & Chu, E.H. (1972). A two-factor hypothesis of freezing injury. Evidence from Chinese hamster tissue-culture cells. *Exp. Cell Res.*, Vol. 71, No. 2, pp. (345-355)
- Mazur, P. & Schneider, U. (1986). Osmotic responses of preimplantation mouse and bovine embryos and their cryobiological implications. *Cell Biophys.*, Vol. 8, No. 4, pp. (259-285)
- Meryman, H.T. (2007). Cryopreservation of living cells: principles and practice. *Transfusion*, Vol. 47, No. 5, pp. (935-945)
- Mollamohammadi, S., Taei, A., Pakzad, M., Totonchi, M., Seifinejad, A., Masoudi, N., & Baharvand, H. (2009). A simple and efficient cryopreservation method for feeder-free dissociated human induced pluripotent stem cells and human embryonic stem cells. *Hum. Reprod.*, Vol. 24, No. 10, pp. (2468-2476)
- Mountford, J.C. (2008). Human embryonic stem cells: origins, characteristics and potential for regenerative therapy. *Transfus. Med.*, Vol. 18, No. 1, pp. (1-12)
- Muldrew, K. & McGann, L.E. (1994). The osmotic rupture hypothesis of intracellular freezing injury. *Biophys. J.*, Vol. 66, No. 2 Pt 1, pp. (532-541)
- Nichols, J., Zevnik, B., Anastassiadis, K., Niwa, H., Klewe-Nebenius, D., Chambers, I., Scholer, H., & Smith, A. (1998). Formation of pluripotent stem cells in the mammalian embryo depends on the POU transcription factor Oct4. *Cell*, Vol. 95, No. 3, pp. (379-391)
- Nie, Y., Bergendahl, V., Hei, D.J., Jones, J.M., & Palecek, S.P. (2009). Scalable culture and cryopreservation of human embryonic stem cells on microcarriers. *Biotechnol. Prog.*, Vol. 25, No. 1, pp. (20-31)
- Nishigaki, T., Teramura, Y., Nasu, A., Takada, K., Toguchida, J., & Iwata, H. (2011). Highly efficient cryopreservation of human induced pluripotent stem cells using a dimethyl sulfoxide-free solution. *Int. J. Dev. Biol.*, Vol. 55, No. 3, pp. (305-311)
- Odorico, J.S., Kaufman, D.S., & Thomson, J.A. (2001). Multilineage differentiation from human embryonic stem cell lines. *Stem Cells*, Vol. 19, No. 3, pp. (193-204)
- Okita, K., Ichisaka, T., & Yamanaka, S. (2007). Generation of germline-competent induced pluripotent stem cells. *Nature*, Vol. 448, No. 7151, pp. (313-317)

- Paasch, U., Sharma, R.K., Gupta, A.K., Grunewald, S., Mascha, E.J., Thomas, A.J., Jr., Glander, H.J., & Agarwal, A. (2004). Cryopreservation and thawing is associated with varying extent of activation of apoptotic machinery in subsets of ejaculated human spermatozoa. *Biol. Reprod.*, Vol. 71, No. 6, pp. (1828-1837)
- Park, I.H., Zhao, R., West, J.A., Yabuuchi, A., Huo, H., Ince, T.A., Lerou, P.H., Lensch, M.W., & Daley, G.Q. (2008). Reprogramming of human somatic cells to pluripotency with defined factors. *Nature*, Vol. 451, No. 7175, pp. (141-146)
- Rajala, K., Hakala, H., Panula, S., Aivio, S., Pihlajamaki, H., Suuronen, R., Hovatta, O., & Skottman, H. (2007). Testing of nine different xeno-free culture media for human embryonic stem cell cultures. *Hum. Reprod.*, Vol. 22, No. 5, pp. (1231-1238)
- Rajala, K., Lindroos, B., Hussein, S.M., Lappalainen, R.S., Pekkanen-Mattila, M., Inzunza, J., Rozell, B., Miettinen, S., Narkilahti, S., Kerkela, E., Aalto-Setälä, K., Otonkoski, T., Suuronen, R., Hovatta, O., & Skottman, H. (2010). A defined and xeno-free culture method enabling the establishment of clinical-grade human embryonic, induced pluripotent and adipose stem cells. *PLoS. One.*, Vol. 5, No. 4, pp. (e10246-
- Rao, M. & Condic, M.L. (2008). Alternative sources of pluripotent stem cells: scientific solutions to an ethical dilemma. *Stem Cells Dev.*, Vol. 17, No. 1, pp. (1-10)
- Rao, M. & Condic, M.L. (2009). Musings on genome medicine: is there hope for ethical and safe stem cell therapeutics? *Genome Med.*, Vol. 1, No. 7, pp. (70-
- Raya, A., Rodriguez-Piza, I., Guenechea, G., Vassena, R., Navarro, S., Barrero, M.J., Consiglio, A., Castella, M., Rio, P., Sleep, E., Gonzalez, F., Tiscornia, G., Garreta, E., Aasen, T., Veiga, A., Verma, I.M., Surrallés, J., Bueren, J., & Izpisua Belmonte, J.C. (2009). Disease-corrected haematopoietic progenitors from Fanconi anaemia induced pluripotent stem cells. *Nature*, Vol. 460, No. 7251, pp. (53-59)
- Raya, A., Rodriguez-Piza, I., Navarro, S., Richaud-Patin, Y., Guenechea, G., Sanchez-Danes, A., Consiglio, A., Bueren, J., & Izpisua Belmonte, J.C. (2010). A protocol describing the genetic correction of somatic human cells and subsequent generation of iPSC cells. *Nat. Protoc.*, Vol. 5, No. 4, pp. (647-660)
- Reubinoff, B.E., Pera, M.F., Fong, C.Y., Trounson, A., & Bongso, A. (2000). Embryonic stem cell lines from human blastocysts: somatic differentiation in vitro. *Nat. Biotechnol.*, Vol. 18, No. 4, pp. (399-404)
- Reubinoff, B.E., Pera, M.F., Vajta, G., & Trounson, A.O. (2001). Effective cryopreservation of human embryonic stem cells by the open pulled straw vitrification method. *Hum. Reprod.*, Vol. 16, No. 10, pp. (2187-2194)
- Revazova, E.S., Turovets, N.A., Kochetkova, O.D., Kindarova, L.B., Kuzmichev, L.N., Janus, J.D., & Pryzhkova, M.V. (2007). Patient-specific stem cell lines derived from human parthenogenetic blastocysts. *Cloning Stem Cells*, Vol. 9, No. 3, pp. (432-449)
- Richards, M., Fong, C.Y., Chan, W.K., Wong, P.C., & Bongso, A. (2002). Human feeders support prolonged undifferentiated growth of human inner cell masses and embryonic stem cells. *Nat. Biotechnol.*, Vol. 20, No. 9, pp. (933-936)
- Richards, M., Fong, C.Y., Tan, S., Chan, W.K., & Bongso, A. (2004). An efficient and safe xeno-free cryopreservation method for the storage of human embryonic stem cells. *Stem Cells*, Vol. 22, No. 5, pp. (779-789)
- Richards, M., Tan, S., Fong, C.Y., Biswas, A., Chan, W.K., & Bongso, A. (2003). Comparative evaluation of various human feeders for prolonged undifferentiated growth of human embryonic stem cells. *Stem Cells*, Vol. 21, No. 5, pp. (546-556)

- Ronaghi, M., Erceg, S., Moreno-Manzano, V., & Stojkovic, M. (2010). Challenges of stem cell therapy for spinal cord injury: human embryonic stem cells, endogenous neural stem cells, or induced pluripotent stem cells? *Stem Cells*, Vol. 28, No. 1, pp. (93-99)
- Sathananthan, H., Pera, M., & Trounson, A. (2002). The fine structure of human embryonic stem cells. *Reprod. Biomed. Online.*, Vol. 4, No. 1, pp. (56-61)
- Schneider, U. & Maurer, R.R. (1983). Factors affecting survival of frozen-thawed mouse embryos. *Biol. Reprod.*, Vol. 29, No. 1, pp. (121-128)
- Silva, J. & Smith, A. (2008). Capturing pluripotency. *Cell*, Vol. 132, No. 4, pp. (532-536)
- Skottman, H., Stromberg, A.M., Matilainen, E., Inzunza, J., Hovatta, O., & Lahesmaa, R. (2006). Unique gene expression signature by human embryonic stem cells cultured under serum-free conditions correlates with their enhanced and prolonged growth in an undifferentiated stage. *Stem Cells*, Vol. 24, No. 1, pp. (151-167)
- Stojkovic, M., Lako, M., Stojkovic, P., Stewart, R., Przyborski, S., Armstrong, L., Evans, J., Herbert, M., Hyslop, L., Ahmad, S., Murdoch, A., & Strachan, T. (2004). Derivation of human embryonic stem cells from day-8 blastocysts recovered after three-step in vitro culture. *Stem Cells*, Vol. 22, No. 5, pp. (790-797)
- Strelchenko, N., Verlinsky, O., Kukharencov, V., & Verlinsky, Y. (2004). Morula-derived human embryonic stem cells. *Reprod. Biomed. Online.*, Vol. 9, No. 6, pp. (623-629)
- Sum, A.K. & de Pablo, J.J. (2003). Molecular simulation study on the influence of dimethylsulfoxide on the structure of phospholipid bilayers. *Biophys. J.*, Vol. 85, No. 6, pp. (3636-3645)
- Sum, A.K., Faller, R., & de Pablo, J.J. (2003). Molecular simulation study of phospholipid bilayers and insights of the interactions with disaccharides. *Biophys. J.*, Vol. 85, No. 5, pp. (2830-2844)
- Sun, N., Longaker, M.T., & Wu, J.C. (2010). Human iPS cell-based therapy: considerations before clinical applications. *Cell Cycle*, Vol. 9, No. 5, pp. (880-885)
- T'joen, V., De, G.L., Declercq, H., & Cornelissen, M. (2011). An Efficient, Economical Slow-Freezing Method for Large-Scale Human Embryonic Stem Cell Banking. *Stem Cells Dev.*,
- Takahashi, K., Tanabe, K., Ohnuki, M., Narita, M., Ichisaka, T., Tomoda, K., & Yamanaka, S. (2007). Induction of pluripotent stem cells from adult human fibroblasts by defined factors. *Cell*, Vol. 131, No. 5, pp. (861-872)
- Takahashi, K. & Yamanaka, S. (2006). Induction of pluripotent stem cells from mouse embryonic and adult fibroblast cultures by defined factors. *Cell*, Vol. 126, No. 4, pp. (663-676)
- Thirumala, S., Gimble, J.M., & Devireddy, R.V. (2010). Evaluation of methylcellulose and dimethyl sulfoxide as the cryoprotectants in a serum-free freezing media for cryopreservation of adipose-derived adult stem cells. *Stem Cells Dev.*, Vol. 19, No. 4, pp. (513-522)
- Thomson, J.A., Itskovitz-Eldor, J., Shapiro, S.S., Waknitz, M.A., Swiergiel, J.J., Marshall, V.S., & Jones, J.M. (1998). Embryonic stem cell lines derived from human blastocysts. *Science*, Vol. 282, No. 5391, pp. (1145-1147)
- Thomson, J.A., Kalishman, J., Golos, T.G., Durning, M., Harris, C.P., Becker, R.A., & Hearn, J.P. (1995). Isolation of a primate embryonic stem cell line. *Proc. Natl. Acad. Sci. U. S. A*, Vol. 92, No. 17, pp. (7844-7848)



- Thomson, J.A., Kalishman, J., Golos, T.G., Durning, M., Harris, C.P., & Hearn, J.P. (1996). Pluripotent cell lines derived from common marmoset (*Callithrix jacchus*) blastocysts. *Biol. Reprod.*, Vol. 55, No. 2, pp. (254-259)
- Trump, B.F., YOUNG, D.E., ARNOLD, E.A., & Stowell, R.E. (1965). EFFECTS OF FREEZING AND THAWING ON THE STRUCTURE, CHEMICAL CONSTITUTION, AND FUNCTION OF CYTOPLASMIC STRUCTURES. *Fed. Proc.*, Vol. 24, pp. (S144-S168)
- Unger, C., Skottman, H., Blomberg, P., Dilber, M.S., & Hovatta, O. (2008). Good manufacturing practice and clinical-grade human embryonic stem cell lines. *Hum. Mol. Genet.*, Vol. 17, No. R1, pp. (R48-R53)
- Vajta, G., Holm, P., Greve, T., & Callesen, H. (1997). Survival and development of bovine blastocysts produced in vitro after assisted hatching, vitrification and in-straw direct rehydration. *J. Reprod. Fertil.*, Vol. 111, No. 1, pp. (65-70)
- Vajta, G., Holm, P., Kuwayama, M., Booth, P.J., Jacobsen, H., Greve, T., & Callesen, H. (1998). Open Pulled Straw (OPS) vitrification: a new way to reduce cryoinjuries of bovine ova and embryos. *Mol. Reprod. Dev.*, Vol. 51, No. 1, pp. (53-58)
- Vajta, G. & Nagy, Z.P. (2006). Are programmable freezers still needed in the embryo laboratory? Review on vitrification. *Reprod. Biomed. Online.*, Vol. 12, No. 6, pp. (779-796)
- Wagh, V., Meganathan, K., Jagtap, S., Gaspar, J.A., Winkler, J., Spitkovsky, D., HESCsheler, J., & Sachinidis, A. (2011). Effects of cryopreservation on the transcriptome of human embryonic stem cells after thawing and culturing. *Stem Cell Rev.*, Vol. 7, No. 3, pp. (506-517)
- Watanabe, K., Ueno, M., Kamiya, D., Nishiyama, A., Matsumura, M., Wataya, T., Takahashi, J.B., Nishikawa, S., Nishikawa, S., Muguruma, K., & Sasai, Y. (2007). A ROCK inhibitor permits survival of dissociated human embryonic stem cells. *Nat. Biotechnol.*, Vol. 25, No. 6, pp. (681-686)
- Wernig, M., Meissner, A., Foreman, R., Brambrink, T., Ku, M., Hochedlinger, K., Bernstein, B.E., & Jaenisch, R. (2007). In vitro reprogramming of fibroblasts into a pluripotent ES-cell-like state. *Nature*, Vol. 448, No. 7151, pp. (318-324)
- Wong, R.C., Pebay, A., Nguyen, L.T., Koh, K.L., & Pera, M.F. (2004). Presence of functional gap junctions in human embryonic stem cells. *Stem Cells*, Vol. 22, No. 6, pp. (883-889)
- Wong, R.C., Pera, M.F., & Pebay, A. (2008). Role of gap junctions in embryonic and somatic stem cells. *Stem Cell Rev.*, Vol. 4, No. 4, pp. (283-292)
- Wu, C.F., Tsung, H.C., Zhang, W.J., Wang, Y., Lu, J.H., Tang, Z.Y., Kuang, Y.P., Jin, W., Cui, L., Liu, W., & Cao, Y.L. (2005). Improved cryopreservation of human embryonic stem cells with trehalose. *Reprod. Biomed. Online.*, Vol. 11, No. 6, pp. (733-739)
- Xiao, M. & Dooley, D.C. (2003). Assessment of cell viability and apoptosis in human umbilical cord blood following storage. *J. Hematother. Stem Cell Res.*, Vol. 12, No. 1, pp. (115-122)
- Xu, X., Cowley, S., Flaim, C.J., James, W., Seymour, L., & Cui, Z. (2010a). The roles of apoptotic pathways in the low recovery rate after cryopreservation of dissociated human embryonic stem cells. *Biotechnol. Prog.*, Vol. 26, No. 3, pp. (827-837)
- Xu, X., Cowley, S., Flaim, C.J., James, W., Seymour, L.W., & Cui, Z. (2010b). Enhancement of cell recovery for dissociated human embryonic stem cells after cryopreservation. *Biotechnol. Prog.*, Vol. 26, No. 3, pp. (781-788)

- Yu, J., Vodyanik, M.A., Smuga-Otto, K., ntosiewicz-Bourget, J., Frane, J.L., Tian, S., Nie, J., Jonsdottir, G.A., Ruotti, V., Stewart, R., Slukvin, I.I., & Thomson, J.A. (2007). Induced pluripotent stem cell lines derived from human somatic cells. *Science*, Vol. 318, No. 5858, pp. (1917-1920)
- Zhang, X.B., Li, K., Yau, K.H., Tsang, K.S., Fok, T.F., Li, C.K., Lee, S.M., & Yuen, P.M. (2003). Trehalose ameliorates the cryopreservation of cord blood in a preclinical system and increases the recovery of CFUs, long-term culture-initiating cells, and nonobese diabetic-SCID repopulating cells. *Transfusion*, Vol. 43, No. 2, pp. (265-272)
- Zhou, C.Q., Mai, Q.Y., Li, T., & Zhuang, G.L. (2004). Cryopreservation of human embryonic stem cells by vitrification. *Chin Med. J. (Engl. )*, Vol. 117, No. 7, pp. (1050-1055)

## **Part 3**

# **Human Assisted Reproduction Techniques (ART)**



# Vitrification of Oocytes and Embryos

Juergen Liebermann

*Director of Laboratory, Fertility Centers of Illinois, Chicago, IL  
USA*

## 1. Introduction

Currently, controlled ovarian hyperstimulation protocols commonly provide embryos in excess of those needed for fresh transfer. Therefore, techniques have been developed to store these surplus embryos in liquid nitrogen (referred to as cryopreservation) for an indefinite period of time without significant compromise of their quality. Based on data from the Centers for Disease Control and Prevention (CDC) from 2001 to 2004, about 18% of all IVF cycles in the USA used frozen embryos for transfer. In addition, data from the same registry compared live births per transfer using frozen and fresh embryos (25% versus 34% respectively) clearly showing that cryopreservation is an important adjunct to maximize the efficiency of every single patient's oocyte retrieval. The fundamental objectives for successful cryostorage of cells in liquid nitrogen at  $-196^{\circ}\text{C}$  can be summarized as follows: **1)** arresting the metabolism reversibly, **2)** maintaining structural and genetic integrity, **3)** achieving acceptable survival rates after thawing, **4)** maintain of developmental competence post thaw and, **5)** the technique has to be reliable and repeatable.

Furthermore, all methods and protocols for cryopreservation should be developed such that ice crystals formation and growth inside the cells or tissues must either be eliminated or massively suppressed. One recent hotly debated topic in the area of reproductive cryobiology is whether slow-cooling or rapid-cooling protocols both satisfy the fundamental cryo-biological principles for reduction of damage by ice crystal formation during cooling and warming, and which approach is better. It is the case nonetheless, that both methods of cryopreservation of biological material include six principal steps: **1)** initial exposure to the cryoprotectant (intracellular water has to be removed by gradual dehydration, **2)** cooling (slow/rapid) to subzero temperatures ( $-196^{\circ}\text{C}$ ), **3)** storage at low temperature, **4)** thawing/warming by gradual rehydration, **5)** dilution and removal of the cryoprotectant agents and replacement of the cellular and intracellular fluid at precise rate and, **6)** recovery and return to a physiological environment.

Although initially reported in 1985 as a successful cryopreservation approach for mouse embryos, vitrification has taken a backseat in human assisted reproduction. However, the practical advantages of this cryopreservation method have more recently caught the attention of many ART laboratories as a feasible alternative to traditional slow freezing methods. Since 1985 more than 2,100 publications can be found referring to the topic of "vitrification", which is further evidence of the burgeoning growth of interest in this cryopreservation technology. One "drawback" considered by embryologists who are not

familiar with the vitrification technique, is the use of higher concentration of cryoprotectants, which does potentially mean that the vitrification solutions are more toxic than their counterpart solutions used for conventional slow freezing. However, with better understanding of the physical and biological principles of vitrification this has led to numerous successful clinical applications of this technique within the field of assisted reproduction. As of today, all developmental stages of human embryos cultured in vitro have been successfully vitrified and warmed, with resulting offspring. Today, slow freezing technology still has the longest clinical track record, and greater 'comfort level' amongst embryologists. Nevertheless, vitrification with its increasing clinical application is showing a trend of greater consistency and better outcomes when compared to slow freezing technology. Therefore, when (not if) IVF programs overcome the fear of the 'unknown', and take on the challenge of the short learning curve with vitrification, then at that point vitrification will become the clinical standard for human embryo cryopreservation.

Cryopreservation at low temperature slows or totally prevents unwanted physical and chemical change. The major disadvantage to using low temperature cryostorage is that it can lead to the crystallization of water, and thereby this approach can create new and unwanted physical and chemical events that may injure the cells that are being preserved. Although the results achieved by slow freezing in many cases seem quite successful (Gardner *et al.*, 2003; Van den Abbeel *et al.*, 2005), ice crystal formation still renders traditional slow-freezing programs generally less consistent in their clinical outcomes. Another downside to the slow freezing approach is the time to complete such freezing procedures for human embryos, which can range from 1.5 to 5hrs. This is due to the fact that the slow rate of cooling attempts to maintain a very delicate balance between multiple factors that may result in cellular damage by ice crystallization and osmotic toxicity. Traditionally slow-freeze embryo cryopreservation has been a positive contributor to cumulative patient pregnancy rates, but ultimately the limitations of current slow-rate freezing methods in ART have become more evident in the shootout with vitrification-based cryostorage.

Vitrification is one of the more exciting developments in ART in recent years that attempts to avoid ice formation altogether during the cooling process by establishing a glassy or vitreous state rather than an ice crystalline state, wherein molecular translational motions are arrested without structural reorganisation of the liquid in which the reproductive cells are suspended. To achieve this glass-like solidification of living cells for cryostorage, high cooling rates in combination with high concentrations of cryoprotectants are used. A primary strategy for vitrifying cells and tissue is to increase the speed of thermal conductivity, while decreasing the concentration of the vitrificants to reduce their potential toxicity. There are two main ways to achieve the vitrification of water inside cells efficiently: **a)** to increase the cooling rate by using special carriers that allow very small volume sizes containing the cells to be very rapidly cooled; and **b)** to find materials with rapid heat transfer. However, one has to take into account that every cell seems to require its own optimal cooling rate, e.g., mature unfertilized oocytes are much more sensitive to chilling injury than any of the cell stages of the pre-implantation embryo. The earliest attempts using vitrification as an ice-free cryopreservation method for embryos were first reported in 1985 (Rall & Fahy, 1985). In 1993 successful vitrification of mouse embryos was demonstrated (Ali & Shelton, 1993). Furthermore, bovine oocytes and cleavage-stages were vitrified and

warmed successfully a few years later (Vajta *et al.* 1998). In 1999 and 2000 successful pregnancies and deliveries after vitrification and warming of human oocytes were reported (Kuleshova *et al.*, 1999; Yoon *et al.*, 2000). Since that time, and because it seems to be that both entities appear to be especially chill-sensitive cells in ART, oocytes and blastocysts seem to receive a potentially significant boost in survival rates by avoiding ice-crystallization using vitrification (Walker *et al.*, 2004). In general, vitrification solutions are aqueous cryoprotectant solutions that do not freeze when cooled at high cooling rates to very low temperature. Interest in vitrification has clearly risen as evinced by the almost exponential growth of scientific publications about vitrification. Vitrification is very simple, requires no expensive programmable freezing equipment, and relies especially on the placement of the embryo in a very small volume of vitrification medium (referred also as “minimal volume approach”) that must be cooled at extreme rates not obtainable in traditional enclosed cryo-storage devices such as straws and vials. The importance of the use of a small volume, also referred to „minimal volume approach“ was described and published in 2005 (Kuwayama *et al.*, 2005; Kuwayama, 2007). In general, the rate of cooling/warming and the concentration of the cryoprotectant required to achieve vitrification are in inversely related. In addition, recent publications have shown the dominance of warming rate over cooling rates in the survival of oocytes subjected to a vitrification procedure (Serki & Mazur, 2009; Mazur & Seki, 2011).

During vitrification, by using a cooling rate in the range of 2,500 to 30,000°C/min or greater, water is transformed directly from the liquid phase to a glassy vitrified state. The physical definition of vitrification is the solidification of a solution at low temperature, not by ice-crystallization but by extreme elevation in viscosity during cooling (Fahy *et al.*, 1984; Fahy 1986). Vitrification of the aqueous solution inside cells can be achieved by increasing the speed of temperature change, and by increasing the concentration of the cryoprotectant used. However, a major potential drawback of vitrification is the use of high concentration of cryoprotectant, and an unintentional negative impact of these cryoprotectants in turn can be their toxicity, which may affect the embryo and subsequent development in utero. It is therefore essential to achieve a fine balance between the speed of cooling and the concentration of the vitrifying cryoprotectants. This is necessitated by the practical limit for the rate of cooling, and the biological limit of tolerance of the cells for the concentration of toxic cryoprotectants being used to achieve the cryopreserved state. It is important to note that recently published papers (Takahashi *et al.*, 2005; Liebermann & Tucker, 2006; Liebermann, 2009, 2011) have shown that the use of relatively high concentration of cryoprotectants such as 15% (vol/vol) ethylene glycol (EG) used in an equimolar mixture with dimethyl sulphoxide (DMSO) had no negative effect on the perinatal outcomes from blastocyst transfers following vitrification when compared with those from fresh blastocyst transfers.

Vitrification in principle is a simple technology, that is potentially faster to apply, and relatively inexpensive; furthermore, it is becoming clinically established, and is seemingly more reliable and consistent than conventional cryopreservation when carried out appropriately (Tucker *et al.*, 2003; Liebermann & Tucker, 2004).

Cryoprotectant agents are essential for the cryopreservation of cells. Basically two groups of cryoprotectants exist: **1**) permeating (*glycerol, ethylene glycol, dimethyl sulphoxide*); and **2**) non-permeating (*saccharides, protein, polymers*) agents. The essential component of a vitrification

solution is the permeating agent. These compounds are hydrophilic non-electrolytes with a strong dehydrating effect. Furthermore, these CPAs are able to depress the “freezing point” of the solution. Regarding the high concentration of cryoprotectant used for vitrification, and in view of the known biological and physiochemical effects of cryoprotectants, it is suggested that the toxicity of these agents is a key limiting factor in cryobiology. Not only does this toxicity prevent the use of fully protective levels of these additives, but it may also be manifested in the form of cryo-injury above and beyond that seen occurring due to classical causes of cell damage (osmotic toxicity and ice formation) during cryopreservation. In spite of this, the permeating CPA should be chosen firstly by their permeating property, and secondly on the basis of their potential toxicity. Because the permeating CPA is responsible for the toxicity (*the key limiting factor in cryobiology*), different cryoprotectants have been tested for their relative toxicity, and the results indicate that ethylene glycol (EG; MW 62.02) is the least toxic followed by glycerol. Additionally, these highly permeating cryoprotectants are also more likely to diffuse out of the cells rapidly and the cells regained their original volume more quickly upon warming, thus preventing osmotic injury. Therefore, the most common and accepted cryoprotectant for vitrification procedures is ethylene glycol (EG). Today EG is more commonly used in an equimolar mixture with DMSO. Often additives are added to the vitrification solution such as disaccharides. Disaccharides, for example sucrose, do not penetrate the cell membrane, but they help to draw out more water from cells by osmosis, and therefore lessen the exposure time of the cells to the toxic effects of the cryoprotectants. The non-permeating sucrose also acts as an osmotic buffer to reduce the osmotic shock that might otherwise result from the dilution of the cryoprotectant after cryostorage. In addition, permeating agents are able to compound with intracellular water and therefore water is very slowly removed from the cell. Hence the critical intracellular salt concentration is reached at a lower temperature. Removal of the cryoprotectant agent during warming can present a very real problem in terms of trying to reduce toxicity to the cells. Firstly, because of the toxicity of the vitrification solutions, quick dilution of them after warming is necessary; and secondly, during dilution water permeates more rapidly in to the cell than the cryoprotective additive diffuses out. As a consequence of the excess water inflow the cells are threatened by injury from osmotic swelling. In this situation the non-permeating sucrose acts as an osmotic buffer to reduce the osmotic shock. During warming using a high extracellular concentration of sucrose (e.g., 1.0M) counterbalances the high concentration of the cryoprotectant agents in the cell, as it reduces the difference in osmolarity between the intra- and extracellular compartments. The high sucrose concentration cannot totally prevent the cell from swelling, but it can reduce the speed and magnitude of swelling (Liebermann and Tucker, 2002; Liebermann *et al.*, 2002a; 2003).

## 2. Oocytes

The cryopreservation of human oocytes constitutes an important step forward in Assisted Reproductive Technology (ART) despite the fact that for more than 2 decades oocyte cryopreservation has long been the focus of unsuccessful efforts to perfect its clinical application. More recently, vitrification as an alternative to traditional slow freezing protocols has been shown to provide high degrees of success in vitrified metaphase-II



human oocytes. Although oocyte cryopreservation historically has low efficiency mainly because of low rates of survival, fertilization, and cleavage, data on ~2000 “frozen oocyte” babies born worldwide since 1986 exists. The question arises as to what makes oocytes so unique compared to embryos, besides differences in cell size and membrane permeability? Oocytes have a low volume-to-surface ratio; hence they are less efficient at taking up cryoprotectant and at losing water. Other differences to be considered are **a)** that the maternal DNA is held suspended in the cytoplasm on the meiotic spindle & not within the protective confines of the nuclear membrane, therefore damage in the DNA and microtubules could explain the limited success of oocytes, **b)** the oocyte is arrested in a state primed for activation, and **c)** the changes in its environment can cause parthenogenetic activation. What are the applications then for oocyte cryopreservation in the US? One application would be to preserve fertility in women with malignant/premalignant conditions who would have to undergo treatment that might negatively impact their future ability to have children (50,000 per year <40 yr old), also in women who may want to delay childbearing (“clock-tickers”) because of their careers, partnership status or psychological/emotional reasons. A very interesting approach is donor oocyte banking, which makes the donor-recipient cycle more convenient by facilitating the “egg donation” and allows quarantining of the oocytes, which provides a unique advantage in economy as well as feasibility. Other applications are if a male is unable to produce a semen sample on the day of egg retrieval and or it could also eliminate ethical/moral questions of producing extra embryos. Overall, oocyte cryostorage offers an opportunity to reduce number of embryos generated per IVF cycle, and therefore lessening the pressure on the patient to increase the number of fresh embryos transferred. In addition, while also reducing embryo cryostorage it has the benefit of helping women “retain ownership” of their ability to be genetic parents at a time of their choosing, a time of greater convenience & health. The live born babies from cryopreserved oocytes have shown no apparent increase in congenital anomalies. Although 13 years later after the first slow-freeze birth, the number of reported babies born as a result of vitrified oocytes is now approaching that of slow-frozen oocytes without any increasing risk in congenital abnormalities (Noyes *et al.*, 2009). Vitrification of oocytes does not appear to increase risks of abnormal imprinting or disturbances in spindle formation or chromosome segregation (Trapphoff *et al.*, 2010). It has the greatest potential for successful oocyte cryopreservation and with its increased clinical application is showing a trend to greater consistency and better outcomes (similar to outcomes between fresh or warmed oocytes). Vitrification of oocytes, when applied to properly screened patients, will be a useful technology in reproductive medicine practice and will constitute a major step forward in ART.

Fortunately to date, no significant increase in abnormalities has been reported from these cryostored oocyte pregnancies (Chian *et al.*, 2009), regardless of the historical concerns that cryopreservation of mature oocytes might disrupt the meiotic spindle and thus increase the potential for aneuploidy in the embryos arising from such eggs. These concerns have mostly been allayed by publications that show no abnormal or stray chromosomes from previously frozen oocytes (Gook & Edgar, 1999), and FISH comparison of embryos from fresh and thawed oocytes show no increase in anomalies (Cobo *et al.*, 2001). There also appears to be adequate recovery of the meiotic spindle post-cryopreservation whether using conventional

or vitrification technology (Chen *et al.*, 2004; Bianchi *et al.*, 2005; Larman *et al.*, 2007). The scientific literature on oocyte cryopreservation grows daily it seems. Most reports focus on clinical pregnancy rates (Boldt *et al.*, 2003; Boldt *et al.*, 2006), and as such while this data is helpful to increase our confidence in the technology, it does little to research new directions for oocyte cryopreservation.

### 3. Zygotes

Conventional cryopreservation of pronuclear zygotes (2PN) is well established in countries such as Germany where freezing of later stage human embryos is by law or by ethical reasons not allowed. The time to complete the conventional protocol to cryopreserved zygotes is 98min. In Germany the clinical pregnancy outcomes arising from the frozen/thawed 2PN cycles is about 18%, with an implantation of around 10% per embryo transferred. The time to complete vitrification of zygotes requires approximately 12min. Recently successful vitrification of 2PN with high survival (~ 90%), cleavage rates on day-2 (>80%), and blastocyst formation of 31% and pregnancies were reported (Park *et al.*, 2000; Jelinkova *et al.*, 2002; Liebermann *et al.*, 2002b; Al-Hasani *et al.*, 2007). Zygote vitrification implemented as a clinical setting can provide a clinical pregnancy rate of close to 30%, with an implantation rate of 17% (Al-Hasani *et al.*, 2007). The pronuclear stage appears well-able to withstand the vitrification and warming conditions, which is probably due to the significant membrane permeability changes that occur post-fertilization; such changes to the oolemma may also make it more stable and able to cope with the vagaries of the cold-shock and striking osmotic fluctuations that occur during the vitrification process.

### 4. Cleavage stage embryo

Reports of human embryo vitrification have been more frequent. Liebermann and Tucker (2002) using either the cryoloop or the hemi-straw system (HSS) showed post-warming survival rates (after 2 hours of culture of day-3 embryos where more than half of their blastomeres were intact) from 84 to 90% which was dependent on the carrier system used. There was a reasonable further cleavage and compaction rate of 34%. This finding supports previous reports in which high survival rates of eight-cell human embryos using 40% EG were documented (Mukaida *et al.*, 1998). In comparison to traditional slow-rate cryopreservation, a survival rate of cleavage stage embryos of 76% was reported with vitrification (Jericho *et al.*, 2003). Recently reported successful pregnancies and deliveries after vitrification of day-3 human embryos using the OPS have been reported (El-Danasouri and Selman, 2001; Selman and El-Danasouri, 2002). Their results showed a negative correlation between stage of development and survival, eight-cell embryos showed a higher survival rate (79.2%; 62/78) than did embryos with fewer than six cells (21.1%; 11/53) after vitrification (El-Danasouri and Selman, 2001). Despite the fact, that Liebermann and Tucker (2002) achieved a promising post-warming survival rate, overall only about 34% of the surviving embryos had the developmental potential to reach the compaction stage. Recently publications on cleavage stage vitrification provided good outcome data. Loutradi *et al.* (2008) were performing a meta-analysis and systematic review by comparing traditional and vitrification protocols for cleavage stage embryos, and found a survival rate of 84.0% versus 97.0%. In addition, clinical pregnancy rates between 35 and 48%, with implantation rates between 15 to 39% have been reported (Rama Raju *et al.*, 2005; Desai *et al.*, 2007; Li *et al.*,

2007; Balaban *et al.*, 2008). So clearly vitrification appears to have a positive impact on overall embryo utilization. A study on the neonatal outcome of 907 vitrified/warmed cleavage stage embryos found no significant increase in the congenital birth defect rate when compared with pregnancies using fresh cleavage stage embryos (Rama Raju *et al.*, 2009).

## 5. Blastocyst stage

Vitrification of human blastocysts using different carriers shows survival rates of 70% to 90%, with clinical pregnancy rates of 37% to 53% and implantation rates of 20% to 30% ((Yokota *et al.*, 2000, 2001; Reed *et al.*, 2002; Mukaida *et al.*, 2001; 2003; Hiraoka *et al.*, 2004; Vanderzwalmen *et al.*, 2002; 2003; Huang *et al.*, 2005; Liebermann & Tucker, 2006; Liebermann, 2009, 2011).

## 6. The advantage of blastocyst cryopreservation

Activation of the embryonic genome occurs after the 8-cell stage (3 days post-oocyte retrieval) is reached (Braude *et al.*, 1988). If the activation does not occur, the embryo will not survive further. Therefore, the improvement of human IVF outcomes requires identification of embryos that will progress beyond the 8-cell stage. Blastocyst culture (5 days post-oocyte retrieval) allows for the transfer of embryos that clearly have an activated embryonic genome. This requires that the elimination of embryos in extended culture from day 3 to day 5 should depend solely on their inherited survival potential and not be a consequence of an adverse effect exerted by the sequential media used for culture beyond day 3. Additional advantages in cryopreserving at the blastocyst stage are: 1) At this stage a lower numbers of embryos can be transferred in fresh cycles, resulting in less high order multiple pregnancies, 2) The same is true for cryopreserved blastocysts showing higher pregnancy rates and implantation per thawed embryo transferred, 3) Approximately 120 hours (day five) into development the healthy human embryo should be at the blastocyst stage comprised of some 50 to 150 cells, of which about 20 to 30% make up the inner cell mass (ICM), the remainder making up the trophoctoderm (TE), 4) the higher cell number allows better compensation for cryo-injuries, which results in greater viability and faster recovery, 5) the cytoplasmatic volume of the cells is lower, thus the surface-volume ratio is higher, and that in turn makes the penetration of the cryoprotectant faster, and 6) on average fewer embryos per patient were frozen-stored, but each one when thawed has a greater potential for implantation.

Both natural and hormone replacement cycles seem to provide comparable levels of receptivity in naturally cycling women, though they differ in level of convenience. Regardless of the day of cryopreservation of the embryo (whether day 5, 6 or 7), at thawing/warming blastocysts should be treated as if they had been frozen on the fifth day of development. Vitrification of blastocysts has been undertaken utilizing an "open system" (Cryotop; Kitazato Bio Pharma Co. Ltd., Fuji-shi, Japan), and since 2007 on a "closed system" (HSV [High Security Vitrification Kit]; CryoBio System, L'Aigle, France) after a two-step loading with cryoprotectant agents at 24°C. Briefly, blastocysts were placed in equilibration solution, which is the base medium (Hepes-buffered HTF with 20% Serum Supplement Substitution (SSS) containing 7.5% (v/v) ethylene glycol (EG) and 7.5% (v/v) dimethyl sulfoxide (DMSO). After 5-7 min, the blastocysts were washed quickly in vitrification solution, which is the base medium containing 15% (v/v) DMSO, 15% (v/v) EG, and 0.5M sucrose, for 45-60sec and transferred onto the Cryotop or HSV using a micropipette. Immediately after the loading of

not more than two blastocysts in a 1µl drop on the Cryotop, the carrier was plunged into fresh clean liquid nitrogen (LN2). After loading the embryos, the Cryotop was capped under the LN2 to seal and protect the vitrified material prior to cryo storage. In contrast, after loading the HSV, the straw was heat sealed and then plunged in LN2, and stored the same way as the cryotop (Liebermann & Tucker, 2006; Liebermann, 2009, 2011).

To remove the cryoprotectants, blastocysts were warmed and diluted in a two step process. With the Cryotop or HSV submerged in LN2, the protective cap (Cryotop) or inner straw (HSV) were removed, and then both carriers with the blastocysts were removed from the LN2 and placed directly into a pre-warmed (~35-37°C) organ culture dish containing 1ml of 1.0M sucrose. Blastocysts were picked up directly from the Cryotop and placed in a fresh drop of 1.0M sucrose at 24°C. After 5min blastocysts were transferred to 0.5M sucrose solution. After an additional 5min, blastocysts were washed in the base medium and returned to the culture medium (SAGE Blastocyst Medium, Trumbull, CT, USA) until transfer.

Between January 2004 and July 2011 the *Fertility Centers of Illinois* "IVF Laboratory River North" (Chicago) has vitrified 13,568 blastocysts *without artificial shrinkage* before the cryopreservation procedure (Table 1). After 2562 frozen embryo transfers (FET) including day 5 and day 6 blastocysts with a mean age of the patients of  $34.9 \pm 5.1$  years, to date we have seen a survival rate, implantation, and clinical pregnancy rate per transfer (cPR) of 97.3%, 30.2%, and 42.5%, respectively (Table 2). After 7 1/2 years of vitrifying blastocysts the perinatal outcome is as follow: from 687 deliveries with vitrified blastocysts, 852 babies (422 boys and 430 girls) were born (Table 2). No abnormalities were recorded. The singleton, twin and triplet pregnancy rates were 71%, 27%, and 2%, respectively.

Day of Development	Day 5	Day 6	Day 7	Total
Number of Blastocysts vitrified (%)	6220 (46%)	6988 (51%)	360 (3%)	13568

Table 1. Retrospective data from 3,712 patients (average age  $33.8 \pm 4.9$ ) with blastocyst cryopreservation by vitrification from January 2004 till July 2011.

Technique	VIT
Patient's age (y)	$34.9 \pm 5.1$
No. of warmed cycles	2580
No. of transfers	2562
No. of blastocysts warmed	4965
No. of blastocysts survived (%)	4829 (97.3)
No. of blastocysts transferred	4752
Mean no. of blastocysts transferred	1.8
No. of implantations (%)	1432 (30.2)
No. of positive pregnancy/warm (%)	1255 (48.6)
No. of positive pregnancy/VET (%)	1255 (49.0)
No. of clinical pregnancy/warm (%)	1089 (42.2)
No. of clinical pregnancy/VET (%)	1089 (42.5)
Ongoing pregnancies/VET (%)	875 (34.2)
No. of livebirths	852 (422 boys & 430 girls)

Table 2. Retrospective data from the blastocyst cryopreservation program (Fertility Centers of Illinois, Chicago) where vitrification (VIT) technology was applied from January 2004 till July 2011.

When the vitrified-warmed blastocysts were divided into day 5 and day 6 groups, the following data was gather (Table 3 & 4). In 1265 FETs transferring day 5 blastocysts, the survival, implantation, and cPR were 97.6%, 34.8%, and 48.3% compared to 97.2%, 25.3%, and 36.5% of in 1204 day 6 FETs.

Patient's Age	< 35	35-37	38-40	> 40	Donor	Total
Ø Age	30.8±2.6	35.8±0.8	38.8±0.8	42.8±2.0	43.5±4.7	34.6±5.2
Day 5 Cycles	678	248	157	74	112	1269
Day 5 Transfers	677	247	155	74	112	1265
Embryos survived (%)	97.5%	96.9%	98.7%	96.0%	97.7%	97.6
Embryos transferred (MEAN)	1.9	1.8	1.9	1.9	1.8	1.9
Positive Pregnancies/Transfer	56.1%	56.7%	56.1%	51.4%	54.5%	55.8%
Clinical Pregnancies/Transfer	50%	49%	43%	43%	50%	48.3%
Ongoing Pregnancies/Transfer	43%	37%	30%	30%	39%	38.8%
# Sacs	478	152	87	42	69	828
Implantation Rate	37.3%	33.3%	29.7%	29.2%	33.7%	34.8%

Table 3. Retrospective outcome data at FCI from vitrified day 5 blastocysts in regards to the patients age between June 2007 till July 2011.

Patient's Age	< 35	35-37	38-40	> 40	Donor	Total
Ø Age	31.0±2.4	36.0±0.8	38.8±0.8	42.5±1.8	43.9±4.9	35.1±5.0
Day 5 Cycles	586	271	177	103	83	1220
Day 5 Transfers	579	266	176	101	82	1204
Embryos survived (%)	96.7%	97.8%	97.9%	95.2%	99.4%	97.2%
Embryos transferred (MEAN)	1.8	1.8	1.8	1.7	1.8	1.8
Positive Pregnancies/Transfer	43.0%	43.6%	39.2%	31.1%	50.0%	42.1%
Clinical Pregnancies/Transfer	37%	38%	35%	29%	42%	36.5%
Ongoing Pregnancies/Transfer	31%	30%	27%	20%	32%	29.2%
# Sacs	276	128	80	34	41	559
Implantation Rate	25.5%	26.5%	24.8%	19.0%	28.1%	25.3%

Table 4. Retrospective outcome data at FCI from vitrified day 6 blastocysts blastocyst in regards to the patients age between June 2007 till July 2011.

In addition, in 1128 FET using aseptic vitrification, 2041 blastocysts were transferred with a survival, implantation, and cPR of 98.4%, 31.8%, and 44.2%, respectively (Table 5). After 4 1/2 years of vitrifying blastocysts using a closed system the perinatal outcome is as follow: 313 babies (165 boys and 148 girls) were born (Table 5). No abnormalities were recorded.

Technique	aVIT
Patient's age (y)	34.5 ± 5.0
No. of warmed cycles	1132
No. of transfers	1128
No. of blastocysts warmed	2102
No. of blastocysts survived (%)	2069 (98.4)
No. of blastocysts transferred	2041
Mean no. of blastocysts transferred	1.8
No. of implantations (%)	650 (31.8)
No. of positive pregnancy/warm (%)	572 (50.7)
No. of positive pregnancy/VET (%)	572 (53.9)
No. of clinical pregnancy/warm (%)	499 (44.1)
No. of clinical pregnancy/VET (%)	499 (44.2)
Ongoing pregnancies/VET (%)	423 (37.5)
No. of livebirths	313 (165 boys & 148 girls)

Table 5. Retrospective data from the blastocyst cryopreservation program (*Fertility Centers of Illinois, Chicago*) where aseptic vitrification (aVIT) technology was applied from June 2007 till July 2011.

Our data has shown that freezing at the blastocyst stage provides excellent survival, implantation and clinical pregnancy (Liebermann & Tucker, 2006; Liebermann, 2009, 2011). To achieve this data the following points should be considered: a) without a successful blastocyst vitrification storage program, extended culture should never be attempted, b) the blastocyst is composed of more cells and therefore better able to compensate for cryo-injury, c) the cells are smaller thus making cryoprotectant penetration faster, and d) on average fewer embryos per patient are cryo-stored, but each one when thawed, has a greater potential for implantation, often with an opportunity for an ET with a single blastocyst.

Furthermore, a vitrification solution with a mixture of 7.5% EG/DMSO, followed by a 15% EG/DMSO with 0.5M sucrose step is safe for clinical use, giving rise to healthy babies without abnormalities. Vitrification of blastocysts using an open or closed system (Cryotop or HSV) is effective for achieving high implantation and pregnancy rates as seen in fresh embryo transfers. Although the outcome in terms of implantation and clinical pregnancy is significantly different when comparing day 5 blastocyst to day 6 blastocysts, our data should encourage cryopreservation of day 6 blastocysts as well. Based on the data presented, it is clear that the vitrification of Day 6 blastocysts is of clinical value since it can result in live births. This observation is confirmed by Saphiro *et al.* (2001) and Levens *et al.* (2008); they found that blastocyst development rate impacts outcome in slow cryopreserved blastocyst transfer cycles.

In conclusion, vitrification of human blastocysts is a viable and feasible alternative to traditional slow freezing methods. The key to this success lies in the more optimal timing of embryo cryopreservation, e.g. individual blastocysts may be cryopreserved at their optimal stage of development and expansion. In addition, the repeatedly discussed topic of using open systems (direct contact between cells and LN2) and the possible danger of contamination by bacteria, fungus or different strains of virus from LN2, can be avoided by moving forward to a closed system providing lower cooling rates, but without a negative impact on the outcome.

## 7. Contamination of LN2: Open versus closed systems

There are many potential advantages of vitrification in that it is an easy, cheap, fast and an apparently successful cryopreservation method; however, there is one issue that is still up for debate. It has been shown that fungi, bacteria and viruses are able to survive in liquid nitrogen (LN2) (Tedder *et al.*, 1995; Fountain *et al.*, 1997; Bielanski *et al.*, 2000; 2003; Kyuwa *et al.*, 2003; Letur-Konirsch *et al.*, 2003). Given the direct exposure of the human cells as they are directly plunged into LN2 during the vitrification process, this therefore raises the question as to whether the LN2 has to be sterilized, as it may be a possible source of contamination for those cells. To this point there has been no fungal, viral or bacterial contamination that has been described from about 400 publications related to vitrification since the first report in 1985. Bielanski and colleagues (2000) demonstrated a viral transmission rate of 21 % to human embryos stored in open freezing containers under experimental conditions of extremely elevated viral presence; while in contrast all embryos stored in sealed freezing containers were free from contamination. Based on this observation they proposed that the sealing of freezing containers appears to prevent exposure to potential contaminants. Commercial systems to purify LN2 by filtration have been developed, however this technology to date has received little practical application in IVF laboratories that have active cryopreservation programs. While it is not totally clear that contamination is a real risk in everyday use of LN2, nevertheless it may be prudent to consider routine sterilization of LN2 when open carrier systems are used for vitrification, followed by a sealing of that system for cryo-storage. Further there are currently at least three 'closed' sealed vitrification systems that are commercially available, with FDA clearance, that represent successful alternatives to open systems for embryo vitrification (Liebermann, 2009, 2011)

## 8. Conclusions and future directions

Vitrification is a very promising cryopreservation method with many advantages, and an ever increasing clinical track record. A standardized vitrification protocol applicable to all stages of the pre-implantation embryo may not be realistic because of: **a)** different surface-to-volume ratios; **b)** differing cooling rate requirements between oocytes, zygotes, cleavage stage embryos and blastocysts; and **c)** variable chill-sensitivity between these different developmental stages. Currently however, the most widely used protocol applied to any embryo stage is the two-step equilibration in an equi-molar combination of the cryoprotectants ethylene glycol and DMSO, at a concentration of 15% each (v/v) supplemented with 0.5 mol/l sucrose.

For the adoption of vitrification in ART, as with all new technologies, there has been initial resistance; but as clinical data has been accrued, this technology is becoming more commonly adopted as standard procedure in many IVF programs worldwide. With this increased use in human assisted reproduction will come evolution of the vitrification process as it is fine tuned to clinical needs, so pushing forward its development to higher levels of clinical efficiency, utilization and universal acceptance.

## 9. Acknowledgement

The author thank the *Fertility Centers of Illinois* (FCI) and the embryologists at the FCI IVF Laboratory River North for their invaluable contributions and support in pushing vitrification to become our standard protocol for cryopreservation of human oocytes and blastocysts within our program.

## 10. References

- [1] Ali and Shelton (1993). Vitrification of preimplantation stages of mouse embryos. *J Reprod Fertil* 98:459–465.
- [2] Al-Hasani S, Ozmen B, Koutlaki N, Schoepper B, Diedrich K, Schultze-Mosgau A. (2007) Three years of routine vitrification of human zygotes: is it still fair to advocate slow-rate freezing? *Reprod Biomed Online* 14:288-93.
- [3] Balaban B, Urman B, Ata B, Isiklar A, Larman MG, Hamilton R, Gardner DK (2008) A randomized controlled study of human Day 3 embryo cryopreservation by slow freezing or vitrification: vitrification is associated with higher survival, metabolism and blastocyst formation. *Hum Reprod.*23:1976-82.
- [4] Bianchi V, Coticchio G, Fava L, Flamigni C, Borini A (2005) Meiotic spindle imaging in human oocytes frozen with a slow freezing procedure involving high sucrose concentration. *Hum Reprod.* 20:1078-83.
- [5] Bielanski et al. (2000). Viral contamination of embryos cryopreserved in liquid nitrogen. *Cryobiology* 40:110-116.
- [6] Bielanski et al. (2003). Microbial contamination of embryos and semen during long term banking in liquid nitrogen. *Cryobiology* 46:146-152.
- [7] Boldt J, Cline D, McLaughlin D (2003) Human oocyte cryopreservation as an adjunct to IVF - embryo transfer cycles. *Hum. Reprod.* 18:1250-5



- [8] Boldt J, Tidswell N, Sayers A, Kilani R, Cline D (2006) Human oocyte cryopreservation: 5-year experience with a sodium-depleted slow freezing method. *Reprod Biomed Online* 13:96-100.
- [9] Braude P, Bolton V, Moore S (1988) Human gene expression first occurs between the four- and eight-cell stages of preimplantation development. *Nature* 332:459-461.
- [10] Chen CK, Wang CW, Tsai WJ, Hsieh LL, Wang HS, Soong YK (2004) Evaluation of meiotic spindles in thawed oocytes after vitrification using polarized light microscopy. *Fertil Steril* 82:666-72.
- [11] Chian RC, Gilbert L, Huang JY *et al.* 2009 Live birth after vitrification of in-vitro matured human oocytes. *Fertil Steril* 91, 372-376.
- [12] Cobo A, Rubio C, Gerli S, Ruiz A, Pellicer A, Remohi J (2001) Use of fluorescence in situ hybridisation to assess the chromosomal status of embryos obtained from cryopreserved oocytes. *Fertil Steril* 75:354-60.
- [13] Desai N, Blackmon H, Szeptycki J, Goldfarb J. (2007) Cryoloop vitrification of human day 3 cleavage-stage embryos: post-vitrification development, pregnancy outcomes and live births. *Reprod Biomed Online*, 14:208-13.
- [14] El-Danasouri and Selman (2001). Successful pregnancies and deliveries after a simple vitrification protocol for day 3 human embryos. *Fertil Steril* 76:400-402.
- [15] Fahy *et al.* (1984). Vitrification as an approach to cryopreservation. *Cryobiology* 21:407-426.
- [16] Fahy (1986). Vitrification: a new approach to organ cryopreservation. In: Merryman HT (ed.), *Transplantation: approaches to graft rejection*, New York: Alan R Liss, 305-335.
- [17] Fountain *et al.* (1997). Liquid nitrogen freezer: a potential source of microbial contamination of hematopoietic stem cell components. *Transfusion* 37:585-591.
- [18] Gardner *et al.* (2003). Changing the start temperature and cooling rate in a slow-freezing protocol increases human blastocyst viability. *Fertil Steril* 79:407-410.
- [19] Gook DA, Edgar DH (1999) Cryopreservation of the human female gamete: current and future issues. *Hum Reprod* 14:2938-40.
- [20] Huang CC, Lee TH, Chen SU, Chen HH, Cheng TC, Liu CH, *et al.*, (2005) Successful pregnancy following blastocyst cryopreservation using super-cooling ultra-rapid vitrification. *Hum Reprod* 20:122-128.
- [21] Jelinkova *et al.* (2002). Twin pregnancy after vitrification of 2-pronuclei human embryos. *Fertil Steril* 77:412-414.
- [22] Kuleshova *et al.* (1999). Birth following vitrification of a small number of human oocytes: case report. *Hum Reprod* 14:3077-3079.
- [23] Kuwayama M, Vajta G, Ieda S, Kato O (2005) Comparison of open and closed methods for vitrification of human embryos and the elimination of potential contamination. *Reprod Biomed Online*; 11: 608-14.
- [24] Kuwayama M (2007) Highly efficient vitrification for cryopreservation of human oocytes and embryos: the Cryotop method. *Theriogenology* 67:73-80.
- [25] Kyuwa *et al.* (2003). Experimental evaluation of cross-contamination between cryotubes containing mouse 2-cell embryos and murine pathogens in liquid nitrogen tanks. *Exp Anim* 52:67-70.

- [26] Larman MG, Minasi MG, Rienzi L, Gardner DK (2007) Maintenance of the meiotic spindle during vitrification in human and mouse oocytes. *Reprod Biomed Online* 15:692-700.
- [27] Levens ED, Whitcomb BW, Henessy S, James AN, Yauger BJ, Larsen FW 2008 Blastocyst development rate impacts outcome in cryopreserved \blastocyst transfer cycles. *Fertility and Sterility*, 90, 2138-2143.
- [28] Letur-Kornisch et al. (2003). Safety of cryopreservation straws for human gametes or embryos: a study with human immunodeficiency virus-1 under cryopreservation conditions. *Hum Reprod* 18:140-144.
- [29] Li Y, Chen ZJ, Yang HJ, Zhong WX, Ma SY, Li M. 2007 Comparison of vitrification and slow-freezing of human day 3 cleavage stage embryos: post-vitrification development and pregnancy outcomes. *Zhonghua Fu Chan Ke Za Zhi*. 42:753-5.
- [30] Liebermann et al. (2002a). Potential importance of vitrification in reproductive medicine. *Biol Reprod* 67:1671-1680.
- [31] Liebermann et al. (2002b). Blastocyst development after vitrification of multipronucleate zygotes using the flexipet denuding pipette (FDP). *RBMOnline* 4:146-150.
- [32] Liebermann and Tucker (2002). Effect of carrier system on the yield of human oocytes and embryos as assessed by survival and developmental potential after vitrification. *Reproduction* 124:483-489.
- [33] Liebermann et al. (2003). Recent developments in human oocyte, embryo and blastocyst vitrification: where are we now? *RBMOnline* 7:623-633.
- [34] Liebermann and Tucker (2004). Vitrifying and warming of human oocytes, embryos, and blastocysts: vitrification procedures as an alternative to conventional cryopreservation methods *Mol Biol* 254:345-364.
- [35] Liebermann J, Tucker MJ 2006 Comparison of vitrification versus conventional cryopreservation of day 5 and day 6 blastocysts during clinical application. *Fertility and Sterility* 86, 20-26.
- [36] Liebermann J 2009 Vitrification of human blastocysts: an update. *Reproductive BioMedicine Online* 19:Suppl 4, 105-114.
- [37] Liebermann J (2011) More than six years of Blastocyst Vitrification - What is the verdict? *US Obstetrics and Gynecology*, 5: 14-17.
- [38] Loutradi KE, Kolibianakis EM, Venetis CA, Papanikolaou EG, Pados G, Bontis I, Tarlatzis BC 2008 Cryopreservation of human embryos by vitrification or slow freezing: a systematic review and meta-analysis. *Fertil Steril*. 90:186-93.
- [39] Mazur P, Seki S (2011) Survival of mouse oocytes after being cooled in a vitrification solution to -196°C at 95° to 70,000 °C/min and warmed at 610° to 118,000 °C/min: A new paradigm for cryopreservation by vitrification. *Cryobiology* 62: 1-7.
- [40] Mukaida et al. (1998). Vitrification of human embryos based on the assessment of suitable conditions for 8-cell mouse embryos. *Hum Reprod* 13:2874-2879.
- [41] Mukaida T, Nakamura S, Tomiyama T, Wada S, Kasai M (2001) Takahashi K Successful birth after transfer of vitrified human blastocysts with use of a Cryoloop containerless technique. *Fertil Steril* 2001;76:618 -623
- [42] Mukaida T, Takahashi K, Kasai M (2003) Blastocyst cryopreservation: ultrarapid vitrification using Cryoloop technique. *Reprod Biomed Online* 6:221-225

- [43] Noyes N, Porcu E, Borini A. (2009) Over 900 oocyte cryopreservation babies born with no apparent increase in congenital anomalies. *Reprod Biomed Online* 18:769-76.
- [44] Park et al. (2000). Ultra-rapid freezing of human multipronuclear zygotes using electron microscope grids. *Hum Reprod* 15:1787-1790.
- [45] Rall and Fahy (1985). Ice-free cryopreservation of mouse embryos at -196 °C by vitrification. *Nature* 313:573-575.
- [46] Rama Raju GA, Haranath GB, Krishna KM, Prakash GJ, Madan K. (2005) Vitrification of human 8-cell embryos, a modified protocol for better pregnancy rates. *Reprod Biomed Online*. 2005;11:434-7.
- [47] Rama Raju GA, Jaya Prakash G, Murali Krishna K, Madan K. (2009) Neonatal outcome after vitrified day 3 embryo transfers: a preliminary study. *Fertil Steril*. 92:143-8
- [48] Reed ML, Lane M, Gardner DK, Jensen NL, Thompson J (2002) Vitrification of human blastocysts using the Cryoloop method: successful clinical application and birth of offspring. *J Assist Reprod Genet* 2002;19:304-306.
- [49] Selman and El-Danasouri (2002). Pregnancies derived from vitrified human zygotes. *Fertil Steril* 77:422-423.
- [50] Seki S, Mazur P (2009) The dominance of warming rate over cooling rate in the survival of mouse oocytes subjected to a vitrification procedure. *Cryobiology* 59: 75-82
- [51] Shapiro B, Richter K, Harris D, Daneshmand S 2001 A comparison of day 5 and 6 blastocysts transfers. *Fertility and Sterility* 75, 1126 -1130.
- [52] Takahashi et al. (2005) Perinatal outcome of blastocyst transfer with vitrification using cryoloop: a 4-year follow-up study. *Fertil Steril* 84:88-92.
- [53] Tedder, R.S., Zuckerman, M.A., Goldstone, A.H., Hawkins AE, Fielding A, Briggs EM. et al. (1995) Hepatitis-B transmission from contaminated cryopreservation tank. *Lancet* 346, 137-140.
- [54] Trapphoff et al. (2010) DNA integrity, growth pattern, spindle formation, chromosomal constitution and imprinting patterns of mouse oocytes from vitrified pre-antral follicles. *Human Reproduction* 25, 3025-3042.
- [55] Tucker et al. (2003). Cryopreservation protocols. In *Color Atlas of Human Assisted Reproduction: Laboratory and Clinical Insights*, eds. P Patrizio, V Guelman and MJ Tucker, pp 257-276, Lippincott, Williams and Wilkins, Philadelphia.
- [56] Vajta et al. (1998). Open pulled straws (OPS) vitrification: a new way to reduce cryoinjuries of bovine ova and embryos. *Mol Reprod Dev* 51: 53-58.
- [57] Van den Abbeel et al. (2005). Slow controlled-rate freezing of sequentially cultured human blastocysts: an evaluation of two freezing strategies. *Hum Reprod* 20: 2939-45.
- [58] Vanderzwalmen P, Bertin G, Debauche Ch, Standaert V, van Roosendaal E, Vandervorst M, et al., (2002) Births after vitrification at morula and blastocyst stages: effect of artificial reduction of the blastocoelic cavity before vitrification. *Hum Reprod* 17:744 -751.
- [59] Vanderzwalmen P, Bertin G, Debauche Ch, Standaert V, Bollen N, van Roosendaal E, et al., (2003) Vitrification of human blastocysts with the hemistraw carrier: application of assisted hatching after thawing. *Hum Reprod* 18:1501-1511.

- 
- [60] Walker et al. (2004). Vitrification versus programmable rate freezing of late stage murine embryos: a randomized comparison prior to application in clinical IVF. *RBMOnline* 8:558-568.
- [61] Yokota Y, Sato S, Yokota M, Ishikawa Y, Makita M, Asada T, et al. (2000) Successful pregnancy following blastocyst vitrification. *Hum Reprod* 15:1802-1803.
- [62] Yokota Y, Sato S, Yokota M, Yokota H, Araki Y (2001) Birth of a healthy baby following vitrification of human blastocysts. *Fertil Steril* 75:1027-1029.
- [63] Yoon et al. (2000). Pregnancy and delivery of healthy infants developed from vitrified oocytes in a stimulated in vitro fertilization-embryo transfer program [letter]. *Fertil Steril* 74:180-181.

# Oocyte Cryopreservation for the Elective Preservation of Reproductive Potential

Catherine Bigelow and Alan B. Copperman  
*Mount Sinai School of Medicine, New York, NY  
USA*

## 1. Introduction

Cryopreservation has been a technique used in reproductive endocrinology and infertility medicine since the early 1980s. Embryo cryopreservation, specifically, has been widely used in many in vitro fertilization (IVF) programs worldwide. This method has been well studied and is a common strategy employed for storing supernumerary embryos after IVF cycles, among other applications. Oocyte cryopreservation, which involves cryopreservation of unfertilized human ova, is a newer procedure that is gaining popularity due to its many benefits, including delay of childbearing, fertility preservation for cancer patients, and avoidance of ethical, religious or legal dilemmas surrounding embryo cryopreservation. While this technique is still considered “experimental,” oocyte cryopreservation is rapidly gaining acceptance in the field of fertility preservation. The current chapter discusses the multifaceted reasons for delayed childbearing, the applications of oocyte cryopreservation, and technical aspects of this procedure. Additionally, arguments are presented to counter the “experimental” label of oocyte cryopreservation and obstetric and perinatal outcome data are analyzed.

## 2. The history of human oocyte cryopreservation

The first human pregnancy after cryopreservation and thaw of an 8-cell embryo occurred in 1983 (Trounson & Mohr, 1983). The first reports of mature human oocyte cryopreservation also occurred in the 1980s, with the first live birth after oocyte cryopreservation using a slow-freeze method being reported in 1986 (Chen, 1986). In this early case report, mature oocytes were cryopreserved using a slow-freeze, rapid-thaw method and DMSO was used as a cryopreservant (Figure 1). Chen achieved an egg survival rate of 80%, with an 83% fertilization rate in the thawed surviving oocyte population. This cohort of 40 oocytes ultimately resulted in one viable twin gestation. Despite this promising early work, significant advances in the field of oocyte cryopreservation did not occur until decades later.

Since the first reports of successful egg freezing, there have been many changes and advances in the protocols and techniques utilized to maximize post-thaw success rates. Alterations in cryopreservants and media have been tested and improved in the past three decades. Replacement of sodium with choline in the cryopreservation media has been shown to improve cryopreservation outcomes (Quintans et al., 2002; Stachecki et al., 1998). Alternative strategies, including trehalose injection have also been introduced in attempts to improve survival of cryopreserved oocytes (Eroglu et al., 2000; Jain & Paulson, 2006).

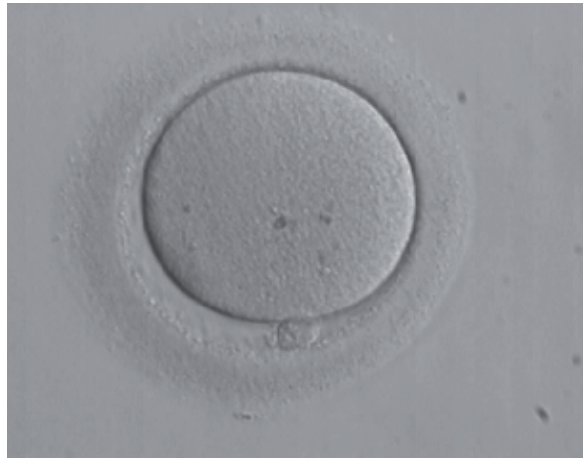

*Courtesy of Reproductive Medicine Associates of New York, LLP.*

Fig. 1. Mature human oocyte.

The introduction of vitrification led to the first live birth after this technique in 1999 (Kuleshova et al., 1999). Vitrification of embryos has been shown to be reliable (Kolibianakis et al., 2009) and vitrification is now routinely applied to oocytes. The efficiency of both oocyte cryopreservation methods has been studied and shows similar trends in improvement. While more data exists for slow-freeze cryopreservation, due solely to the number of years that this method has been available, vitrification data is equally promising. In a 2006 meta-analysis, Oktay et al. demonstrated live birth rates increasing after slow-freezing from 21.6% per transfer (from 1996 to 2004) to 32.4% (from 2002 to 2004). The vitrification data showed a similar trend, with a live birth rate of 29.4% before 2005 and 39% after 2005 (Oktay et al., 2006). Through the use of intracytoplasmic sperm injection (ICSI), many of the concerns about zona pellucida hardening from cryopreservation were bypassed. This ability to augment fertilization of thawed oocytes altered the outlook on oocyte cryopreservation and made this a more viable option for fertility preservation.

More recently, experimentation with cryopreservation of ovarian tissue through orthotopic or heterotopic transplantation has been attempted. The first child born after ovarian tissue cryopreservation was documented in 2004, to a woman who had a history of chemotherapy and radiation treatment for lymphoma (Donnez et al., 2004). Due to fewer studies on optimal cryopreservation protocols and methods of tissue selection, this technique has been considered more experimental than oocyte cryopreservation. In addition, optimal strategies for enhancing graft revascularization are limited in the literature and ideal tissue size has not been established. In a case series of 13 patients who underwent ovarian tissue cryopreservation due to various diseases requiring chemotherapy, large strips (8-10mm x 5mm) and small cubes (2mm x 2mm) of ovarian tissue were both effective in restoring ovarian function (Donnez et al., 2011). However, due to small numbers of human patients having undergone this procedure and a lack of standardized protocols, these outcomes are difficult to interpret. Furthermore, appropriate candidate selection for ovarian tissue cryopreservation has not been defined. Due to waning primordial follicle counts as women age, it has been suggested that ovarian tissue cryopreservation should be limited, at the very least, to women <40 years of age (Oktay, 2002). Some concern also exists about the risk of ovarian metastasis and the reintroduction of malignant cells upon transplantation of thawed

ovarian tissue. Minimal residual disease (MRD) in cryopreserved ovarian tissue of patients with leukemia has been demonstrated in humans, with the prevalence of MRD in chronic myeloid leukemia and acute lymphoblastic leukemia as high as 33% and 70%, respectively (Dolmans et al., 2010). Given these risks, strategies to effectively test cryopreserved ovarian tissue for evidence of MRD are required before this technique can be widely utilized in clinical practice. In light of these uncertainties, ovarian tissue cryopreservation is still in its infancy with regard to fertility preservation. Additionally, immature oocyte cryopreservation is being studied but is also in early experimental stages, according to the American Society for Reproductive Medicine (ASRM) (ASRM Practice Committee, 2008). This potentially new frontier is still being studied in primate models and preliminary human studies are ongoing.

These changes in cryopreservants, rates of freezing, fertilization, and protocols for cryopreservation have improved outcomes. As research funding, referring provider knowledge, and patient interest in oocyte cryopreservation increase, we can anticipate continued advancements in the field of fertility preservation.

### 3. The significance of human aging

Human aging has been well-studied and is a known contributor to the decline in fertility experienced by women. Female fecundity, or the ability to produce offspring, declines with advancing age. This is partially due to decreased numbers of oogonia, which have a steady rate of atresia from birth, with a more rapid decline around the age of 37.5 years. Numbers of oogonia, or primordial fetal oocytes, are maximal at 20 weeks' gestation, totaling between six and seven million. At birth, this number has already declined to one to two million; a mere 400,000 oocytes remain at the beginning of puberty. While this number still seems rather high, only around 500 of these oocytes are destined for maturation and ovulation. The remainder will be lost through a highly controlled system of follicular atresia and apoptosis (Williams Gynecology, 2008 Ed.), until around 1000 oocytes remain at the time of menopause (Figure 2). Since women now live longer, a larger portion of their lives are spent in reproductive senescence, and the need for reproductive assistance due to challenges associated with diminished ovarian reserve has increased (Faddy et al., 1992).

Recent research has suggested that there may be a population of oogonial stem cells, similar to that seen in males for lifelong spermatocyte production. Several studies have pointed toward the presence of mitotically-active germline stem cells in the mammalian ovary (Johnson et al., 2004; Pacchiarotti et al., 2010; Parte et al., 2011; Zou et al., 2009). Many groups have conducted experiments which have isolated stem cells capable of sustaining oocyte and follicle production *in vitro*. While these results are controversial and disputed by some (Byskov et al., 2005), the potential for regeneration of oocytes and follicular development throughout the female life span is an exciting and promising future area in assisted reproduction.

Mathematical models have been developed in order to generate prediction rules for numbers of remaining oocytes and reproductive capacity. Oocyte atresia appears to follow a bi-exponential pattern, with a more rapid decline in oocyte number occurring after a critical number of 25,000 follicles remain around the age of 37.5 years (Faddy et al., 1992). According to this model, around 1000 follicles remain at the age of 51, which corresponds to the median age of menopause in the general population. Other authors have studied histological samples to identify the rate of recruitment of non-growing follicles (NGF) in human ovaries from

prenatal samples through menopause (Wallace & Kelsey, 2010). This model suggests that up to 81% of the variance in non-growing follicles is due to age alone. Interestingly, the authors' mathematical model demonstrates an increased rate of non-growing follicle recruitment until the age of 14 years old, after which NGF recruitment decreases until the menopause. Using this best-fitting asymmetric peak mathematical model, it may be possible to predict ovarian reserve in women based on age and guide discussions of fertility preservation in women seeking information about oocyte cryopreservation.

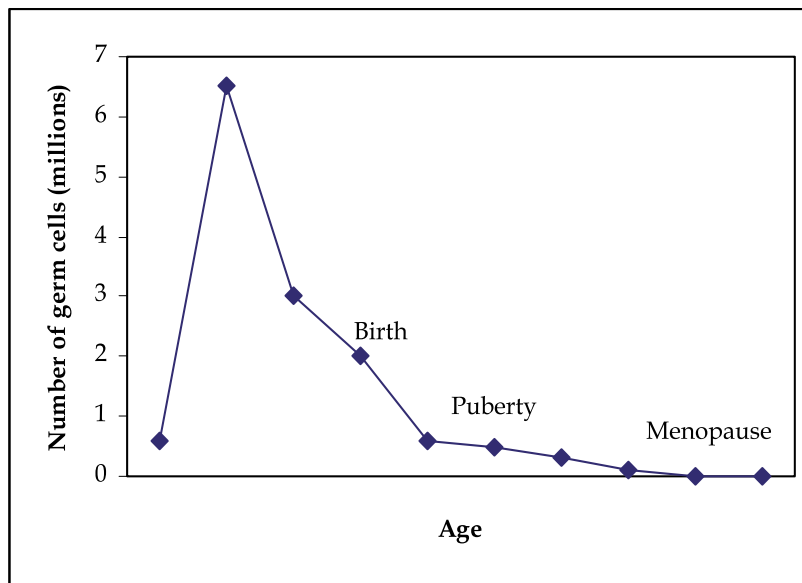

Fig. 2. Number of germ cells across the human female lifespan. Germ cells peak around 6 months post-conceptional age at a level of 6-7 million. At birth, this number has declined to around 2 million germ cells remaining in the infant ovary. Further decline occurs during the rest of the lifespan, with ~500,000 remaining at puberty and only ~1000 oocytes left at menopause.

Though we have some clinical tools to help predict a woman's reproductive capacity, including hormonal tests and the basal antral follicle count, the ramifications of human aging on reproduction are still variable and difficult to predict. Traditionally, elevated levels of basal follicle stimulating hormone (FSH) and abnormal estradiol (E2) levels have been used to guide physicians who are assessing ovarian reserve. FSH is measured in the early follicular phase of the menstrual cycle, when luteal inhibin levels decrease. Classically, it is measured on day 3 after the onset of menses. Studies have shown that a day 3 FSH level above 15 mIU/mL predicts significantly lower rates of pregnancy (Scott, 1995). Concomitant measure of E2 levels may decrease the rate of false negatives when FSH values are used alone. Estradiol should be thus be measured concurrently with day 3 FSH testing. The basal antral follicle count (BAFC) has also been used widely in the field of reproductive endocrinology and infertility to help predict ovarian reserve. BAFC <4 has a specificity of 98.7% when predicting non-pregnancy following IVF (Gibreel et al., 2009). BAFC may therefore be an appropriate measure of ovarian reserve in women undergoing infertility evaluation. Meta-analysis has also shown that BAFC of less than 4 has a sensitivity and specificity to predict cycle cancellation of 66.7% and 94.7%,



respectively. Additionally, women with a BAFC of less than 4 are 37 times more likely to have their cycle cancelled (Gibreel et al., 2009).

A newer marker for predicting ovarian reserve is anti-Müllerian hormone, or AMH, which has been in the literature since the early 2000s (Gruijters et al., 2003). Serum AMH levels are constant throughout the menstrual cycle, unlike FSH or E2, and are not affected by other hormone levels. Because of these relatively constant levels, AMH may be useful for predicting ovarian response to stimulation cycles for IVF; its predictive power seems to be similar to that of the BAFC (La Marca et al., 2009). Additionally, AMH is secreted in primary, preantral, and small antral follicles, which are thought to comprise the pool of ovarian reserve (Figure 3). This endocrine marker is secreted by granulosa cells and reflects the transition of resting primordial follicles to growing follicles (Sowers et al., 2008). Additionally, AMH levels diminish as an FSH-dependent dominant follicle begins to develop (Broekmans et al., 2008), reinforcing its role as a marker of preantral and small antral follicles in the pool of ovarian reserve. AMH is not, on the other hand, expressed in atretic follicles. Therefore, its levels are directly correlated to the number of viable, growing follicles that remain in the ovary. Levels of AMH decline in a predictable fashion as women near the menopausal transition, which has been studied in concordance with declining levels of inhibin-B and increasing levels of FSH (thus reinforcing the soundness of this marker as a predictor of declining ovarian reserve) (Sowers et al., 2008). There is a statistical association between AMH and FSH levels in assessing ovarian reserve. Singer et al. compared the correlation between these two hormones and found that serum AMH level is highly predictive of baseline FSH level. Using these two serum marker levels in combination may prove to be a useful predictor of ovarian reserve (Singer et al., 2009).

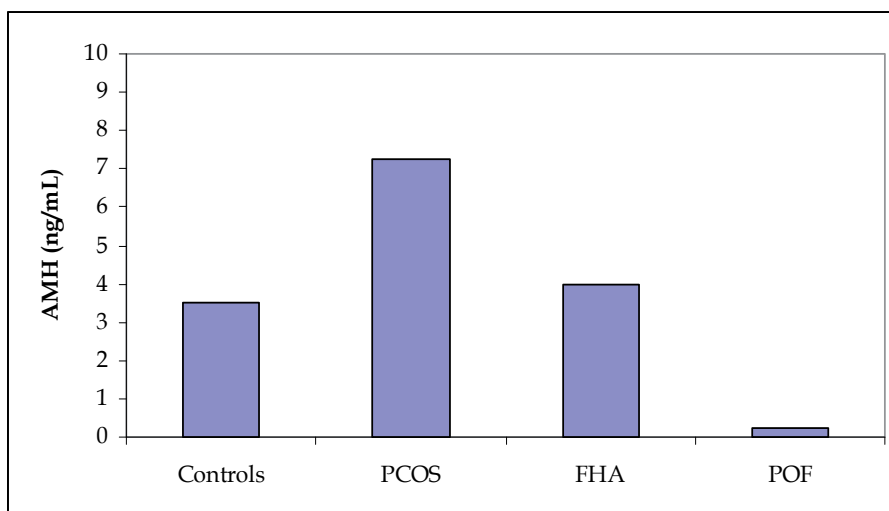

Fig. 3. Mean AMH plasma levels in patients and controls. Women with PCOS have significantly higher levels of plasma AMH and women with POF have significantly lower levels, when compared to controls and women with FHA ( $p < 0.05$ ). PCOS: Polycystic Ovarian Syndrome; FHA: Familial Hypothalamic Amenorrhea; POF: Premature Ovarian Failure. Adapted from Broekmans et al., 2008.

In our NYC-based infertility clinic, women presenting for new oocyte cryopreservation consultations were retrospectively evaluated. Of the 519 women presenting for new patient consultation, approximately 1/3 initiated oocyte cryopreservation cycles. The best predictors of successful oocyte cryopreservation cycles were (in order) BAFC, day 3 FSH, and age (all  $p < 0.05$ ) (Barritt et al., 2010). Importantly, providers must remember that all of these tests and models attempt to predict the *quantity* of oocytes available for future reproduction. Unfortunately, tests to predict oocyte *quality* are still lacking. Models incorporating multiple variables may end up being the best predictor of ovarian reserve and ART cycle success, though many still consider age the best predictor of ovarian reserve and reproductive potential.

The risk of aneuploidy is increased in older oocytes, which leads to higher rates of chromosomally abnormal fetuses and spontaneous abortion. Approximately 15-20% of pregnancies end in spontaneous abortion, or miscarriage (Barron, 1968). Maternal age has long been recognized as a risk factor for pregnancy loss. Risk of chromosomal abnormalities, decreased fecundity, and prevalence of comorbid medical illnesses rise with increasing age – all of which may lead to spontaneous abortion (Barron, 1968). Aneuploidy is thought to affect around 20% of human oocytes (Jones, 2008). Some hypothesize that rates of aneuploidy increase with age through a “two-hit” pathway: nondisjunction followed by an inability of the oocyte to detect the chromosomal abnormality. Nondisjunction, or inappropriate chromosomal separation during meiosis I, is a leading cause of aneuploidy and increases with maternal age. Oocytes from older women may have decreased cohesive bonds between chromosomes, further predisposing them to meiotic errors (Jones, 2008). Additionally, as oocytes age, they may be unable to detect errors in recombination and sister chromatid separation.

It has been well-documented that infertility rates increase with age and that reproductive aging is primarily related to oocyte age. One prospective study demonstrated infertility rates increasing from 8% in women aged 19-26 years to 13-14% in women aged 27-34 years, and ultimately to 18% for women aged 35-39 years (Dunson, 2004). Similarly, there is a decline in success rates of fresh-cycle, non-donor oocyte IVF as a woman ages. Live birth rates per embryo transfer have been documented around 47.5% for women <35 years old, with a progressive decline to 17.0% in women 41-42 years of age, according to 2009 data from the Society of Assisted Reproductive Technologies (SART) (SART, 2009). In light of this data, strategies to preserve fertility for young women are paramount.

#### **4. Changing demographics of reproductive-aged women**

In the United States, there has been a notable shift in the demographics of reproductive-aged women. Many women are delaying childbearing in the setting of career pursuits and shifting societal expectations of gender roles. An analysis of Danish fertility rates from 1980-2001 showed an increase in the mean age of childbearing of 3 years over the 21 year period (Hvidtfeldt et al., 2010). There appears to be a global shift in reproduction leading to delayed childbearing and increased maternal age.

Reasons for delaying childbearing are multifaceted and complex. Perceived career threats are a very real and prevalent issue in young women of reproductive age (Willett et al., 2010). For women in professional programs, fear about extension of training, loss of future career

opportunities and concern for pregnancy complications are all significantly higher than in men. These concerns lead to choosing between career training and childbearing, thus risking subfertility by delaying reproduction for the sake of a woman's profession. Studies at our center have evaluated motivations for and trends in elective preservation of fertility in women seeking care at a New York City infertility clinic. Women seeking elective egg freezing were likely to have a high level of education, with all women having at least a bachelor's degree and 75% holding a master's or professional degree. These women were all single, nulliparous, and the majority expressed a desire to be sure they had taken advantage of all reproductive opportunities (Gold et al., 2006). Half of women interviewed described being pressured by their "biological clock" and many wanted to freeze eggs as an "insurance policy," though did not anticipate needing to use them. Interestingly, the mean patient age was 39 years old and 65% of women had reported only recently learning about egg freezing technology. In a multicenter analysis, more than 3000 women called to inquire about fertility preservation. Of these women, those who actually completed a cycle had a significantly higher average age of 37.1 years; patients who were older than 35 had fewer cycles that resulted in the recommended number of metaphase II oocytes for cryopreservation (Frank Sage et al., 2008). This may suggest an inadequate awareness of the age-related decline in fertility that occurs as part of normal human aging. Most studies on reproductive outcomes after oocyte cryopreservation (including oocyte survival rates, fertilization rates, and number of pregnancies) have analyzed women under the age of 35 (Jain & Paulson, 2006). Because of this limitation in the body of literature on oocyte cryopreservation, providers should ideally cryopreserve oocytes in women <35 years of age. As oocyte cryopreservation becomes more publicized and accurate information about declining female fertility is disseminated, the mean age of cryopreservation may decrease.

Trends in the local and national economy have been studied in relation to elective medical procedures, including oocyte cryopreservation. Costs of oocyte and embryo cryopreservation have been evaluated through the LIVESTRONG database of 154 participating reproductive centers. For the average patient, the cost of oocyte cryopreservation is around \$7,800, compared to an average of \$9,300 for embryo cryopreservation (Beck et al., 2010). The costs of fertility preservation are variable based on geography and center. In a New York City private IVF program, annual per capita income showed significant positive correlation with new consults for oocyte cryopreservation. Additionally, as annual unemployment rates increased, the number of new consults significantly decreased (Flisser et al., 2009).

Oocyte cryopreservation has many social and ethical advantages over embryo cryopreservation. Embryo cryopreservation remains the standard recommendation for fertility preservation according to ASRM guidelines, mainly due to the amount of literature studying this technique. Single women, however, may encounter social issues with freezing embryos. The option to extend fertility without the need for a male partner or sperm donor is frequently appealing to women who are not in a long-term relationship. The discomfort of anonymity associated with sperm donors is eliminated with egg freezing. Other potential issues include decisions regarding paternity and legal obligations for patients who undergo directed sperm donation, strategies for disposing of embryos if a woman gets married later in life, and how to handle the disposition of embryos if the egg donor dies and does not have explicit advanced directives in place (Jain & Paulson, 2006). These dilemmas are all circumvented with oocyte cryopreservation. Additionally, infertility centers avoid the often difficult task of synchronizing cycles between oocyte donors and recipients, in the case of

third party reproduction (Oktay et al., 2010). Improvement in coordination of care, costs, and the ability to quarantine oocytes for infectious disease testing are benefits of oocyte cryopreservation for egg donors.

Fertility preservation for cancer patients undergoing potentially sterilizing chemotherapy and radiation has been a widely accepted application of oocyte cryopreservation. Management of all of the gynecologic cancers has the potential to affect ovarian reserve. Cervical cancer often requires pelvic radiation and endometrial cancer is frequently treated with hysterectomy and bilateral salpingo-oophorectomy. Therapy for breast cancer, the most common cancer in women in the United States, commonly utilizes cyclophosphamide, which has well-known ovary-toxic effects and leads to premature ovarian failure (Oktay & Sönmezer, 2007). Ovarian stimulation is necessary for both oocyte and embryo cryopreservation for these patients; stimulation protocols have been developed to avoid excessive estrogen exposure in women with estrogen-responsive cancers. For patients who do not need to immediately initiate chemotherapy (or other therapies that may affect the ovary), cryopreservation is a viable option for fertility preservation. In a retrospective data analysis of a NYC infertility clinic from 2005-2007, women presenting for pre-cancer treatment oocyte cryopreservation cycles were evaluated. The average time between initial consultation and completion of the cryopreservation cycle was  $37.2 \pm 22.5$  days, and a mean number of 17.8 oocytes were retrieved across the 4 patients studied (Barritt et al., 2008). Early referral to a fertility center is vital, as patients will require 2 weeks of stimulation after menses in order to retrieve oocytes for cryopreservation. Many oncologists are supportive of their patients' desire to preserve fertility, even in light of the potential delay of chemotherapy and need for gonadotropin stimulation. Women who require immediate initiation of chemotherapy or pediatric cancer patients may benefit from ovarian tissue cryopreservation, though studies of this technique are still quite small and this strategy has not yet been widely used (Oktay & Sönmezer, 2007).

Reproductive endocrinologists approaching the patient interested in elective fertility preservation need to recognize the demographic shifts and societal attitudes toward oocyte cryopreservation. The wide variety of applications of oocyte cryopreservation, including delayed childbearing, ethical opposition to embryo cryopreservation, improvement in third party oocyte donation and fertility preservation for cancer patients, all highlight the advantages of this emerging reproductive technology.

## 5. Technical aspects of oocyte cryopreservation

Oocyte cryopreservation is a delicate and complex process. Mammalian cells are generally stored at a temperature of  $-196^{\circ}\text{C}$ , at which no biological activity takes place. Cryopreservation must transform human oocytes from a biologically active system at  $37^{\circ}\text{C}$  to an inert structure at  $-196^{\circ}\text{C}$ ; oocytes are most vulnerable during this temperature transition. Membrane permeability and kinetics vary throughout the developmental cycle of the oocyte; metaphase II oocytes have demonstrated higher post-cryopreservation survival in a mouse model (Gook & Edgar, 2007). There are three main goals of oocyte cryopreservation: avoidance of ice crystal formation, avoidance of solution effect, and avoidance of osmotic shock (Jain & Paulson, 2006). As water freezes and expands to form ice, *crystal formation* causes shearing forces on organelles and increases intracellular pressure. Additionally, as water transitions from its liquid to solid form, any solutes dissolved in liquid water are excluded from the ice. This can lead to very high, if not toxic,

levels of non-liquid solutes and electrolytes, known as *solution effect*. Further damage to intracellular proteins can occur in the presence of these toxic levels of intracellular substances during cryopreservation. Finally, *osmotic shock* can occur in the setting of rapid rewarming, during which rapid free water shifts lead to cell shrinking and swelling to accommodate alterations in extracellular osmotic pressure. These three goals are achieved through the use of different cryoprotectant chemicals. Cryoprotectants facilitate oocyte cryopreservation by generating an osmotic gradient by which water can exit the oocyte. Permeating cryoprotectants are able to enter the oocyte, thereby preventing cell shrinkage during osmosis of water to the extracellular space.

Two protocols for oocyte cryopreservation exist, slow-freeze methods and vitrification. While slow-freezing is the most widely used and has been studied more in the literature, recent studies in embryos suggest that vitrification may have improved post-thaw survival rates, though it is still not clear whether there are significant differences in clinical pregnancy rates. These methods are discussed here and are analyzed in light of recent evidence of comparative efficacy. In addition, methods for ovarian tissue cryopreservation are briefly discussed.

### 5.1 Slow freeze

Slow freezing has traditionally been the more widely-used technique for mature oocyte cryopreservation. This technique was first described in 1972 by Whittingham et al. after successful slow freeze and post-thaw survival of mouse embryos (Whittingham et al., 1972). The technology was first applied to human embryos in 1983, and resulted in successful post-thaw survival and pregnancy after cryopreservation (Trounson & Mohr, 1983), followed by live birth after mature oocyte cryopreservation in 1986 (Chen, 1986).

Slow freeze cryopreservation is achieved using initial low cryoprotectant concentrations to reduce toxicity while the oocyte is still metabolically active (Jain & Paulson, 2006). The temperature is lowered gradually, at rates between 0.3-2°C/minute. This slow rate of cooling allows retardation of the metabolic rate in the oocyte without accumulating toxic levels of cryoprotectant. Propanediol (PROH) and dimethylsulfoxide (DMSO) are permeating cryoprotectants which form hydrogen bonds with intracellular water molecules and prevent ice crystal formation, thus achieving the first goal of successful cryopreservation. Additionally, the presence of PROH dilutes electrolyte concentrations by remaining in solution (due to its low freezing point); this prevents solution effect, which is the second goal of cryopreservation. PROH is preferred to DMSO as a cryoprotectant, as it is thought to be less toxic to the oocyte (Renard & Babinet, 1984). Additionally, using 0.2-0.3M sucrose as a nonpermeating cryoprotectant during oocyte dehydration seems to improve post-thaw survival (Fabbri et al., 2001). "Seeding" the extracellular solution with an ice crystal occurs around -6°C, during which an ice front grows and excludes solutes, thereby increasing their concentration around the oocyte. This ice front can potentially cause intracellular damage to the oocyte if it comes in contact with the cell or can lead to gas bubble formation (Ashwood et al., 1988). The oocyte is maintained at -6°C for 10 to 30 minutes before being further cooled to -32°C. At this point, metabolic activity in the oocyte is extremely low and the cell is plunged into a Dewar vessel of liquid nitrogen to vitrify any remaining cryoprotectant solution (Figure 4). The Dewar vessel is capable of maintaining a near constant temperature for the frozen oocytes during storage.



Fig. 4. Liquid nitrogen Dewar vessel, used for freezing and storing cryopreserved oocytes. *Courtesy of Reproductive Medicine Associates of New York, LLP.*

Thawing of embryos occurs at a rate of 4-25°C/minute. A relatively rapid temperature transition is needed to prevent recrystallization of water in the cell. Nonpermeating cryoprotectants, such as sucrose or other disaccharides, are utilized to help prevent osmotic shock during thawing, as high levels of permeating cryoprotectants are present intracellularly (Jain & Paulson, 2006). This helps achieve the third goal of cryopreservation (Figure 5).

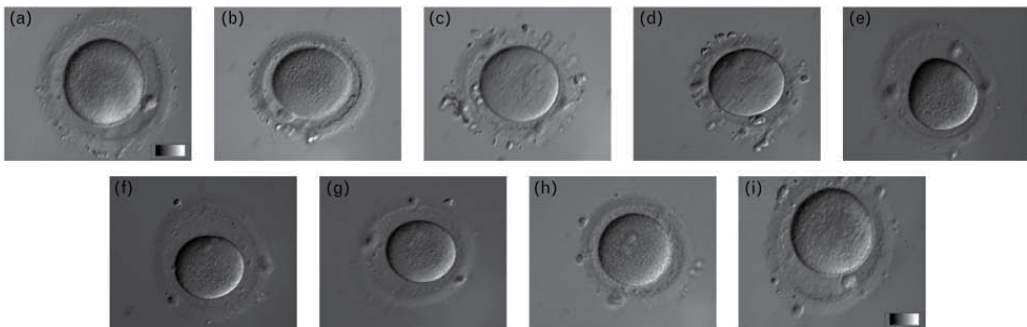

Fig. 5. Oocyte volume changes during freezing and thawing with slow-freeze protocol. (a) De-cumulated oocyte. (b)-(d) Oocyte undergoing freezing stages. (e)-(h) Oocyte undergoing thawing stages of slow-freeze protocol. (i) Oocyte after cryopreservation. *Images courtesy of Herrero et al., 2011.*

Slow freezing has limitations. First, this method is expensive and requires programmable freezing equipment that must be purchased by the IVF laboratory. This poses a substantial cost to many centers. Additionally, this method is extremely time-consuming, taking embryologists at least 90 minutes to successfully cryopreserve oocytes. Despite these drawbacks, this technique is still the most widely used and has the most literature available about tested protocols and outcomes.

## 5.2 Vitrification

Vitrification, which literally means “the act or process of converting into glass,” is an alternative method to slow freeze cryopreservation. This technique uses high concentrations of cryoprotectants and a rapid cooling rate to convert liquid intracellular water directly into a glassy, vitrified state.

This method of oocyte cryopreservation was first described in humans in 1986 (Fahy et al., 1986), with the first live birth after vitrification occurring in 1999 (Kuleshova et al., 1999). Oocytes are directly exposed to liquid nitrogen which practically eliminates ice crystal formation, due to the rapid cooling rate, around 20,000°C/minute. This minimizes the risk of physical damage to the oocyte from shearing of organelles or increased intracellular pressure. The oocyte is converted rapidly into an amorphous state (Figure 6). A plastic straw containing cryoprotectants and the oocyte is directly plunged into the liquid nitrogen. While initial studies of these “cryoprotectant cocktails” found them to be incredibly toxic, extensive evaluation has indicated that the combination with minimal toxicity is a combination of a high concentration of ethylene glycol (5.5M) and sucrose (1.0M) (Ali & Shelton, 1993). Further modification of the cryoprotectant protocols has decreased the concentration of ethylene glycol to 5.0M (Kuwayama et al., 2005a). Other groups have had high success with vitrification using 2.5M ethylene glycol, 0.5M sucrose and 2.1M DMSO (Gook & Edgar, 2007). These changes in methodology have led to continued improvement in vitrification outcomes, including improved oocyte post-thaw survival, fertilization rates, and pregnancy outcomes.

Some studies have reported the potential for disease transmission, especially viral illnesses, through direct contact with contaminated liquid nitrogen using open-carrier systems for vitrification (Bielanski et al., 2000, 2003), in which there is direct contact between the cryoprotectant media and liquid nitrogen. Closed-carrier system vitrification, in which oocytes are not in direct contact with liquid nitrogen, have been shown to have similar blastocyst survival, pregnancy rates, and live birth rates as open-carrier systems (Kuwayama et al., 2005b), without the theoretical risk of horizontal viral transmission (Bielanski et al., 2000). Closed-carrier systems cool at a slower rate (around 200°C/minute) but have similar rates of post-thaw embryo development, and may demonstrate similar efficacy (Jain & Paulson, 2006).

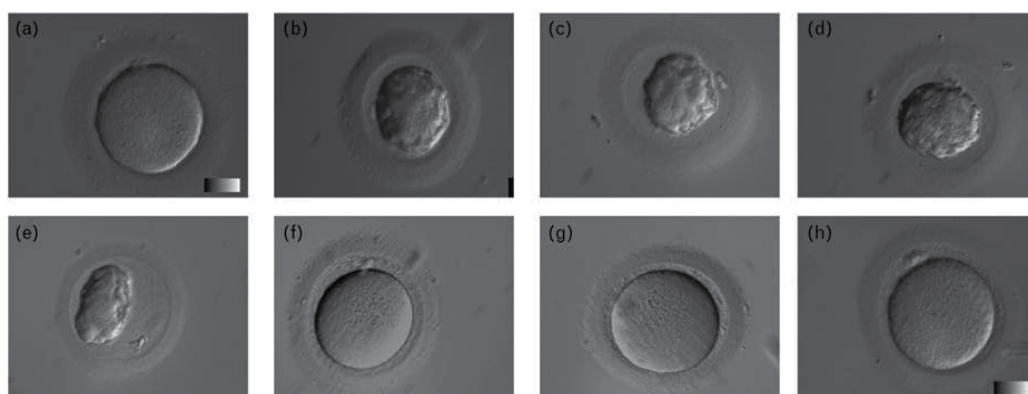

Fig. 6. Oocyte volume changes during vitrification and thaw. (a) De-cumulated oocyte before cryopreservation. (b)-(e) Oocyte undergoing vitrification. (f)-(g) Oocyte during warming phase of vitrification protocol. (h) Oocyte after cryopreservation. *Images courtesy of Herrero et al., 2011.*

Vitrification has its own drawbacks. This method, too, is very expensive for IVF centers to implement in terms of costs of freezing and thawing media. Additionally, this technique has a high learning curve, which must be considered. On the other hand, vitrification does not take as much time as slow freezing due to the rapid cooling procedure and does not require expensive embryology lab equipment. As vitrification continues to be used and data accrued about the success of this method, it is likely to alter the choice of cryopreservation protocols worldwide.

### 5.3 Slow freeze versus vitrification for oocyte cryopreservation

Slow freezing reports first began 13 years before literature on vitrification emerged. Both of these methods have demonstrated increasing efficiency over time, with continually improving live birth and ongoing pregnancy rates per transfer (Oktay et al., 2006). Although there is a lag in the data for vitrification outcomes, the number of babies born after vitrification is approaching that of slow freeze methods for oocyte cryopreservation (Noyes et al., 2009).

In a recent meta-analysis of randomized controlled trials (RCTs) comparing these two methods, vitrification was found to have better post-thawing survival rates for cleavage stage embryos (odds ratio [OR] 6.35, 95% confidence interval [CI] 1.14, 35.26) and for blastocysts (OR 4.09, 95% CI 2.45, 6.84) (Kolibianakis et al., 2009). A significantly higher number of embryos cryopreserved in the cleavage stage developed into blastocysts following vitrification. Clinical pregnancy rates, however, demonstrated no significant difference between slow freeze and vitrification protocols. This meta-analysis was undertaken to evaluate and summarize the available evidence for cryopreservation of human embryos, not oocytes. Additionally, the data amassed for this meta-analysis came from only 6 RCTs, only one of which commented on live birth rates. The authors, in light of this limited data, call for well-designed randomized controlled trials to further study differences between and advantages or disadvantages of these cryopreservation techniques.

Recently, a prospective randomized comparison of slow freeze versus vitrification for mature human oocyte cryopreservation was performed in Brazil (Smith et al., 2010). In this study, women with supernumerary oocytes retrieved (more than nine) were consented and randomized to either slow freeze or vitrification of these supernumerary oocytes. Demographic characteristics between the two groups of women were similar, including patient age, baseline laboratory values, and number of oocytes collected. Semen parameters were also similar between the groups and all oocytes were inseminated by intracytoplasmic sperm injection (ICSI). Oocyte survival after thawing was significantly higher in those having undergone vitrification. Additionally, a higher percentage of vitrified oocytes were fertilized (77% vs. 67% of slow freeze oocytes;  $p < 0.03$ ) and more of these zygotes underwent cleavage from day 1 to day 2 (84% vs. 71%, respectively;  $p < 0.01$ ). Perhaps the most important outcome for any assisted reproductive technology, however, is the rate of pregnancy. Biochemical and clinical pregnancy rates per thaw cycle were significantly higher in the vitrification group compared to the slow freeze group (46% vs. 17% and 38% vs. 13%, respectively;  $p < 0.01$  and  $p < 0.02$ ) (Table 1). Additionally, the two groups had similar rates of spontaneous abortion following embryo transfer. Perinatal outcomes were not evaluated by these authors. From case reports evaluating live births following oocyte cryopreservation, the average gestational age at delivery for slow freeze was 36.9 weeks, compared to 39 weeks' gestational age at delivery after vitrification (Noyes et al., 2009). This



data suggests improved efficiency and a clinical advantage of oocyte vitrification for elective fertility preservation. Reproductive endocrinologists should be aware of this recent data when considering the implementation of oocyte cryopreservation into their clinical practice and when counseling patients seeking fertility preservation.

	Slow-Freeze	Vitrification	p-value
Number of cycles	30	48	NA
Oocytes thawed	238	349	NA
Oocytes thawed per treatment (mean $\pm$ SE)	7.9 $\pm$ 0.5	7.3 $\pm$ 0.3	NS
Immediate post-thaw survival (%)	159/238 (67%)	281/349 (81%)	<0.001
4-hour post-thaw survival (%)	155/238 (65%)	260/349 (75%)	<0.01
Fertilization (%)	104/155 (67%)	200/260 (77%)	<0.03
Cleavage from Day 1 to Day 2	74/104 (71%)	168/200 (84%)	<0.01
Biochemical pregnancies per cycle (%)	5/30 (17%)	22/48 (46%)	<0.01
Clinical pregnancies per cycle (%)	4/30 (13%)	18/48 (38%)	<0.02
Clinical pregnancy per oocytes thawed (%)	4/238 (1.7%)	18/349 (5.2%)	<0.03

NA = not applicable; NS = not significant. SE = standard error. *Adapted and reproduced with permission from Smith et al., 2010.*

Table 1. Oocyte survival and function following slow-freeze or vitrification for cryopreservation

#### 5.4 Ovarian tissue cryopreservation

Ovarian tissue cryopreservation (oophoropexy) and transplantation can also be considered for female children who will survive childhood cancers but have potentially sterilizing chemotherapy and/or radiation. Ovarian tissue cryopreservation was first described using a sheep model (Gosden et al., 1994). After oophorectomy, strips of ovarian cortex were cryopreserved using a slow-freeze protocol with DMSO. Ovarian tissue was cooled to  $-140^{\circ}\text{C}$  before being plunged into liquid nitrogen and stored for 3 weeks. Tissue was thawed and grafted back into the same animal after removal of the remaining ovary, after which animals were returned to the pasture and normal husbandry conditions. This protocol has been followed in human studies of ovarian tissue cryopreservation (Donnez et al., 2011). After thawing, decortication of the patient's atrophic ovaries occurs before transplantation of cryopreserved tissue (Donnez & Dolmans, 2009). Return of ovarian function appears to occur between 3.5-6.5 months after transplantation, as evidenced by an increase in E2 and decreased basal FSH levels. In a small case study, the duration of ovarian activity after transplantation appears to be about 2-5 years (Donnez et al., 2011). Heterotopic transplantation of fresh ovarian tissue to the forearm has been successful in 2 cancer patients with return of ovarian function (Oktay et al., 2001). Forearm heterotopic transplantation of cryopreserved ovarian tissue has been successful in primates (Schnorr et al., 2002), and preliminary studies of this technique in humans are ongoing.

#### 6. Is oocyte cryopreservation “experimental?”

The American Society for Reproductive Medicine (ASRM) published a committee opinion in 2008 which stated that “the experimental nature of oocyte cryopreservation suggests

potential for clinical application [...] it might therefore be acceptable [...] with appropriate informed consent under the auspices of an IRB" (ASRM Practice Committee, 2008). This "experimental" label was first published by ASRM in 2006. Some studies have looked at provider compliance with this ASRM practice guideline and likelihood of referral for oocyte cryopreservation. In a retrospective study of 530 IVF centers in the United States, 69% of these centers (365/530) were found to offer oocyte cryopreservation. Of these centers, only 62% do so under IRB approval, while 15% reported having an IRB pending and 18% did not use an IRB at all for oocyte cryopreservation (Beck et al., 2009). Compliance with ASRM guidelines was highest in the northeast (71%) and the size of the program was inversely related to the likelihood that oocyte cryopreservation occurred in conjunction with IRB approval. Still, these numbers indicate relatively high compliance with ASRM guidelines. In a different survey of healthcare providers at 5 United States IVF centers, physician preferences and recommendations were analyzed for practice patterns regarding oocyte cryopreservation. More than half of providers considered the ideal age for oocyte cryopreservation to be less than 35 years and 50% found it acceptable for a woman to preserve fertility in this way with a day 3 FSH value of <13 IU/L. A large proportion of providers were less likely to recommend egg freezing to patients with a low BAFC. Additionally, 89% of physicians were more likely to offer oocyte cryopreservation to their patients if there was a medical indication for the procedure, instead of elective reasons for fertility preservation (Luna et al., 2008). Providers recognized the emerging role oocyte cryopreservation will have in the field of fertility preservation. Thus, despite current reservations regarding which patients to refer for oocyte cryopreservation and ASRM guidelines, physicians view oocyte cryopreservation as a technique that will continue to be used with increasing frequency.

Discussion about the safety and efficacy of oocyte cryopreservation has focused on potential concern about meiotic spindle interruption from freezing, hardening of the zona pellucida (which may decrease rates of fertilization), and the potential risk of anomalies and abnormalities that may arise in the setting of a new technique without much outcome data. The meiotic spindle is a dynamic structure that forms during mitosis and meiosis to facilitate chromosomal segregation. Disruption of the meiotic spindle increases the risk of aneuploidy. These concerns were studied by Rienzi et al. by slow freezing oocytes and looking at the meiotic spindle using computer-assisted polarization microscopy (Rienzi et al., 2004). This technique allowed visualization of the spindle in real time by evaluating living oocytes. Previous studies had used electron microscopy or immunocytochemistry, which requires cell fixation and does not permit evaluation of dynamic spindle activity (reviewed in Eichenlaub-Ritter et al., 2002). Though spindles disappeared in oocytes during the thawing process, all surviving post-thaw oocytes were noted to have intact, functional meiotic spindles. Thus, it appears that cryopreserved oocytes are capable of reforming the meiotic spindle apparatus after thawing (Noyes et al., 2010). Hardening of the zona pellucida (ZP, the transparent glycoprotein envelope that surrounds a mature mammalian oocyte) is thought to occur due to premature cortical granule release during cryopreservation (Jain & Paulson, 2006). This release leads to early hardening of the ZP, which impedes penetration and fertilization by sperm. The advent of ICSI in 1992 introduced a solution to ZP hardening, in which the zona is bypassed by direct injection of the sperm into the oocyte. Additionally, vitrification of oocytes in calcium-free media

appears to reduce zona pellucida hardening and leads to increased fertilization. Embryos obtained from cryopreserved oocytes have a similar incidence of chromosomal abnormalities when compared to control embryos using fluorescence in situ hybridization (FISH) (Cobo et al., 2001). Multiple recent studies have evaluated pregnancy, live birth, and early childhood outcomes in children born after mature oocyte cryopreservation (Borini et al., 2007; Chian et al., 2008a, 2008b; Noyes et al., 2009; Oktay et al., 2006; Wennerholm et al., 2009); these have not documented an increased rate of congenital anomalies among children born after oocyte cryopreservation. These studies are discussed in more detail in the next section.

In light of these concerns about cryopreservation, the ASRM maintains that oocyte cryopreservation should be considered an experimental procedure. The ASRM specifically states that assisted reproductive technology (ART) procedures should be considered “experimental” until “the published medical evidence regarding their [...] overall safety and efficacy is sufficient to regard them as standard medical practice. [This] medical evidence can derive only from appropriately designed, peer-reviewed, published studies performed by multiple independent investigators” (ASRM Practice Committee, 2009). Other authors have supported this statement, by noting that “because the largest demand for oocyte cryopreservation most probably is going to come from women who wish to delay childbearing electively, it is quite likely that several years will be required before sufficient births have occurred to determine the true safety of cryopreserved oocytes” (Jain & Paulson, 2006). Some authors, however, argue against this labeling of oocyte cryopreservation, stating that a variety of commonly used assisted reproductive technologies have never been studied “under the auspices of an IRB” before implementation into standard practice (Noyes et al., 2010).

The safety of oocyte cryopreservation has been evaluated through studies of pregnancy, perinatal, and childhood outcomes, in which over 900 infants have been evaluated (Chian et al., 2000b; Noyes et al., 2009). There does not seem to be an increased risk for adverse pregnancy outcomes or congenital anomalies in pregnancies conceived after oocyte cryopreservation, thaw, fertilization and embryo transfer. Additionally, cryopreservation may introduce an extra safety measure with regard to quarantine for infectious disease, similar to protocols in place for cryobanking of donor sperm. By freezing donated oocytes, additional infectious disease testing can be done months after oocyte retrieval to ensure optimal embryo transfer and pregnancy outcome. In an early 2007 paper by Barritt et al., 4 oocyte donors underwent synchronous ovarian stimulation with 4 recipient patients with impaired ovarian reserve, elevated basal FSH, and prior unsuccessful IVF treatments (Barritt et al., 2007). The donors were given a complete medical examination in accordance with ASRM guidelines for oocyte donors, which included a full history, physical exam, BAFC, and cervical cultures. In addition, these women had serological testing for infectious diseases, including HIV, hepatitis B and C, syphilis, gonorrhea, cytomegalovirus, and a urine drug screen. While this initial workup for oocyte donors seems exhaustive, additional checkpoints for infectious disease testing after an extended period of cryopreservation will further prevent the spread of communicable disease and improve pregnancy outcomes by preventing congenital infections. Data continue to emerge supporting the safety and efficacy of oocyte cryopreservation and it is likely that the “experimental” label will soon be removed from this technique.

Multiple studies from different investigators and institutions have compared the efficacy of oocyte cryopreservation to fresh oocyte cycles. An early IRB-approved prospective study of four donor-recipient oocyte cycles by Barritt et al. demonstrated high pregnancy and implantation rates following slow-freezing and overnight storage before thawing. After ICSI, the authors demonstrated an 89.7% fertilization rate and 91.8% of these fertilized oocytes cleaved normally. Of 23 transferred embryos, 26.1% implanted and 75% of implanted embryos led to clinical pregnancy (Barritt et al., 2007). Cobo et al. performed a study in which fresh oocytes from the same donor were either inseminated directly or vitrified for at least 1 hour before thaw and insemination (Cobo et al., 2008). In comparing embryo quality and clinical outcomes, they found that vitrified/thawed oocytes produced embryos capable of a 47.8% ongoing pregnancy rate, which was similar to fresh oocytes. In addition, Grifo and Noyes performed an age-matched control study of 23 oocyte cryopreservation cycles and fresh oocyte control cycles. Fertilization rates, blastocyst formation, and pregnancy rates were not significantly different between these two matched groups (Grifo & Noyes, 2010). This indicates that frozen/thawed oocytes perform as well as fresh oocytes in ART procedures. Finally, Nagy et al. demonstrated high efficiency of egg cryobanking, with a 55% implantation rate and delivery of 26 live infants. Furthermore, their study showed that twice-frozen gametes (i.e. oocyte cryopreservation followed by fertilization and supernumerary embryo vitrification) can lead to pregnancy after embryo thawing (Nagy et al., 2009). The efficacy of oocyte cryopreservation has thus been established by multiple independent groups in the literature, strengthening the argument to remove its experimental status.

For female cancer patients, treatment regimens of intensive chemotherapy, ionizing radiation, and bone marrow transplantation can lead to premature ovarian failure, with direct impact on the number and viability of remaining oocytes. Gonadotropin-releasing hormone (GnRH) analogues have been studied as a method for fertility preservation before cytotoxic treatments. By suppressing ovarian function and, essentially, rendering the ovary quiescent, it is thought that chemotherapeutics and radiation would not be able to affect post-treatment ovarian function. Unfortunately, this strategy does not have well-documented efficacy in the literature (Maltaris et al., 2009). Additionally, studies are lacking that have documented resultant oocyte and embryo quality following a course of chemotherapy (ASRM Practice Committee, 2008). Consequently, oocyte or ovarian tissue cryopreservation may be more reliable methods of fertility preservation for female cancer patients.

Finally, it is important to consider the ethical dilemmas of embryo cryopreservation that are bypassed by using oocyte cryopreservation. These issues, while not directly related to safety and efficacy of oocyte cryopreservation, provide additional support for arguments about the importance of this method to avoid the moral impasses generated by embryo cryopreservation and storage. Embryo cryopreservation has legal implications worldwide. Ovarian stimulation cycles and IVF procedures frequently lead to supernumerary cryopreserved embryos. Over 400,000 embryos are currently stored in the United States alone (Hoffman et al., 2003), leading to high rates of embryo abandonment in IVF clinics. The issue of embryo disposal versus continued cryopreservation is one which IVF clinics deal with daily.

## 7. Long-term pregnancy and health outcomes after oocyte cryopreservation

Given the evolving nature of the technology and the heterogeneity of patient-population and cryopreservation techniques, the actual “success rate” of egg freezing is unknown. Review of the literature, however, suggests that the efficiency of cryopreservation appears to be improving. One analysis of slow-freezing demonstrated improvement in live birth rates from 21.6% per transfer from 1996 to 2004 to 32.4% from 2002 to 2004 (Oktay et al., 2006). Vitrification data shows a similar trend of improvement: 29.4% live birth rate before 2005 versus 39% after 2005. In a study out of McGill University Health Center, 38 women underwent ovarian stimulation and vitrification of retrieved oocytes. After cryopreservation for one full menstrual cycle, there was an 81% thaw survival rate, 75.6% of oocytes were successfully fertilized, and a 50% pregnancy rate per cycle started was achieved (Chian et al., 2008a). Ultimately, 39.5% of women who initiated ovarian stimulation and cryopreservation cycles gave birth to live infants. Nine of these births were singleton, while the remaining six deliveries were multiples (five twins and one triplet). While initial high rates of spontaneous abortion were documented after oocyte cryopreservation (Borini et al., 2004), these rates have declined with a corresponding increase in live birth rates.

Since the early 2000s, studies have begun reporting pregnancy and neonatal outcomes following oocyte cryopreservation. Borini et al. reported 13 children born after slow freeze cryopreservation in 2004. All babies born were found to have a normal karyotype and no malformations were seen in their study group. They did note, however, a 20% spontaneous abortion rate in their cohort of patients who had undergone oocyte cryopreservation cycles (Borini et al., 2004). In a later study out of Italy, 149 pregnancies occurred after using a slow freeze protocol for oocyte cryopreservation. This group, again, had a relatively high spontaneous abortion rate of 23.5% (Borini et al., 2007). Reports of live births following oocyte cryopreservation have also emerged from groups in China. Chian et al. found that neonates born after ovarian stimulation and oocyte vitrification were all appropriate birthweights, none weighed <2500g. Additionally, all singletons in their cohort were born at term, with a mean gestational age at delivery of 39 1/7 weeks (Chian et al., 2008a). The same group analyzed 165 pregnancies resulting in 200 babies born after vitrification of oocytes at three centers. In their study, multiple gestations were more likely to deliver in the late preterm period (between 34-37 weeks' gestation) – 57% vs. 22% of singleton pregnancies. This is consistent with current expectations for multiple gestations in the general population. Additionally, 74% of multiples in their study were low birth weight (LBW, <2500g), with 5% of the cohort being very low birth weight (VLBW, <1500g). This was in comparison to singleton neonates born after vitrification, only 17% of which were LBW and 0.7% were VLBW. These birth weights are not significantly different when compared to women who spontaneously conceived or had fresh IVF (Chian et al., 2008b). Birthweight was also analyzed in a systematic review of pregnancy outcome data after oocyte cryopreservation and found to be consistently within normal limits (Wennerholm et al., 2009).

Some concerns have been raised about the rate of malformation or congenital anomalies seen in babies born after any assisted reproductive technology. Epigenetic syndromes (such as Beckwith-Weidemann Syndrome and Angelman Syndrome) have been reported as more common, specifically after ICSI (Noyes et al., 2009). With regard to egg freezing, of 105 babies studied by Borini et al. in 2007, only 2 malformations were seen; one infant was born

with choanal atresia and the other with Rubenstein-Taybi syndrome (Borini et al., 2007). Chian et al. analyzed rates of malformations in their 2008 cohort of 200 babies born after vitrification. Overall, only 5 birth defects were noted, for a malformation rate of 2.5% (Chian et al., 2008b). This rate is consistent with that seen in spontaneously conceived pregnancies and those following fresh IVF (Tan et al., 1992). In the Chian study, 2 ventricular septal defects (VSD), 1 case of biliary atresia, 1 club foot and 1 skin hemangioma were described in neonates. In their systematic review of the literature, Wennerholm et al. found that children who underwent karyotype analysis after oocyte cryopreservation were all within normal limits (Wennerholm et al., 2009).

The largest study to date of congenital anomalies following oocyte cryopreservation was published in 2009 by Noyes, Porcu and Borini. In this literature review, the authors identified 936 infants born after oocyte cryopreservation. In this worldwide population of infants, only 12 of 936 had either a major or minor congenital anomaly, for a malformation rate of 1.3% (Noyes et al., 2009). Defects seen included 3 VSD, 3 clubfoot, 1 choanal atresia, 1 biliary atresia, 1 Rubenstein-Taybi syndrome, 1 Arnold-Chiari syndrome, 1 cleft palate, and 1 skin hemangioma; some of these defects have already been discussed from earlier studies (Borini et al., 2007; Chian et al., 2008b). No difference in rates of major or minor congenital anomalies was found when compared to the United States birth outcome data from the Centers for Disease Control and Prevention (CDC). The CDC reports major structural or genetic birth defects occurring in 3% of live births (CDC, 2011); the number of malformations seen after oocyte cryopreservation is, in fact, lower than this national average. Importantly, the birth defects amassed in this group mirror those seen most commonly in the general population. Additionally, the authors stratified the infants between those born after slow freeze versus vitrification protocols. There was no major difference in the rate of anomalies found after these methods of oocyte cryopreservation (1.1% versus 1.5%, respectively). No epigenetic syndromes were found in this international group of infants born after oocyte cryopreservation, though these have been reported for other types of ART.

Ovarian tissue cryopreservation, which has been less studied and is not as widely used as oocyte cryopreservation, has also resulted in successful pregnancies. The first birth after ovarian tissue cryopreservation and autotransplantation was documented in 2004 (Donnez et al., 2004). To date, there have been 13 infants born to 10 women after ovarian tissue cryopreservation (Donnez et al., 2011). Two of these women conceived and delivered two healthy infants in subsequent pregnancies from thawed, transplanted ovarian tissue. These 10 case-reports suggest that ovarian function may be restored anywhere from 2 to 5 years post-transplant of cryopreserved tissue. Women who received chemotherapy before taking measures to preserve ovarian tissue all had significantly decreased length of graft function, compared to those who cryopreserved ovarian tissue before initiating a chemotherapy regimen. All singleton gestations delivered at term, after 37 weeks' gestational age. Additionally, all of the infants born after this method of fertility preservation are alive and healthy, without any known congenital anomalies or perinatal morbidity (Donnez et al., 2011).

Studies of pregnancy outcome and neonatal well-being are extremely important with any new reproductive technology. Perhaps more crucial, however, is the ability to track and register pregnancies that arise out of oocyte cryopreservation cycles. The Human Oocyte

Preservation Experience (HOPE) is a phase IV, multicenter, observational registry in the United States that has been created to prospectively collect data on oocyte cryopreservation and subsequent outcomes (Ezcurra et al., 2009). The goals of this project are twofold: first, to evaluate the safety and efficacy of different oocyte cryopreservation techniques, and second, to assess the safety of these methods in relation to the babies resulting from cryopreserved oocytes. This initiative will follow 400 women over three years who are undergoing oocyte cryopreservation, thawing, and subsequent embryo transfer. Standardized data will be collected for all subjects, including demographic information, laboratory studies, and pregnancy outcomes. Additionally, all babies will be followed for the first year of life to evaluate perinatal and infant outcomes after oocyte cryopreservation. Studies of this nature are crucial for the validation of oocyte cryopreservation as a valuable method for fertility preservation in the United States and removal of its “experimental” categorization by ASRM.

## 8. Conclusion

A variety of ART strategies have been introduced over the past few decades without being deemed “experimental” or requiring IRB approval. Moreover, new procedures in ART have not historically been required to demonstrate improved efficacy over established protocols before being introduced into clinical practice (Noyes et al., 2010). One example is the introduction of ICSI in the 1990s (Palermo et al., 1995). Though ICSI is more invasive than conventional IVF, it was quickly embraced in the field and used widely for couples with severe male factor infertility after extensive informed consent. Other ART techniques, such as frozen embryo storage, prenatal genetic diagnosis (PGD), laser assisted hatching, and even human chorionic gonadotropin (hCG) agonist triggering of ovulation have not required implementation under the “auspices of an IRB.” Instead, informed consent documents highlight risks and benefits of these procedures and infertility centers are expected to honestly present data regarding success rates and outcomes. In light of these inconsistencies, it seems incongruous to require such stringent, IRB-approved regulations for oocyte cryopreservation, which has been shown to produce high survival rates. Clinics should be transparent about their experience, their site-specific pregnancy rates, and the associated perinatal outcomes.

Though oocyte cryopreservation was first introduced more than three decades ago, the past several years have yielded significant enhancement of techniques and documentation of efficacy. Current and future advancements have the potential to preserve reproductive potential for young women with cancer prior to gonadotoxic treatments as well as for those seeking elective preservation of their fertility. As stimulation techniques are simplified, costs are contained, safety and efficacy are documented, and more wide-spread awareness of the reproductive aging process is achieved, it is likely that the number of women who are able to benefit from this new technology will continue to increase.

## 9. References

- Ali J, Shelton JN. Design of vitrification solutions for the cryopreservation of embryos. *Journal of Reproduction and Fertility* 1993; 99(2):471-7.

- Ashwood-Smith MJ, Morris GW, Fowler R, Appleton TC, Ashorn R. Physical factors are involved in the destruction of embryos and oocytes during freezing and thawing procedures. *Human Reproduction* 1988; 3(6):795–802.
- ASRM Practice Committee. Definition of “experimental procedures.” *Fertility and Sterility* 2009; 92(5):1517.
- ASRM Practice Committee. Ovarian tissue and oocyte cryopreservation. *Fertility and Sterility* 2008; 90(Suppl 3):S241-6.
- Barritt J, Luna M, Duke M, Valluzzo L, Howard M, Copperman AB. Prophylactic oocyte cryopreservation for fertility preservation in cancer patients. *Fertility and Sterility* 2008; 89(4 Suppl 1):S19.
- Barritt J, Luna M, Sandler B, Mukherjee T, Duke M, Copperman AB. Elective oocyte freezing for the preservation of fertility: an IRB approved pilot study of over 200 clients. *Fertility and Sterility* 2010; 94(4 Suppl 1):S107.
- Barritt J, Luna M, Duke M, Grunfeld L, Mukherjee T, Sandler B et al. Report of four donor-recipient oocyte cryopreservation cycles resulting in high pregnancy and implantation rates. *Fertility and Sterility* 2007; 87(1):189.e13-e17.
- Beck LN, Exley A, Fischer C, Copperman K, Ezcurra D, Copperman AB. How Compliant Are We With ASRM Guidelines on Oocyte Cryopreservation? *Fertility and Sterility* 2009; 92(3 Suppl 1):S194.
- Beck LN, Sileo M, Copperman AB. The Average Cost of Fertility Preservation for Female Cancer Patients. *Fertility and Sterility* 2010; 94(4 Suppl 1):S105.
- Bielanski A, Nadin-Davis, S, Sapp T, Lutze-Wallace C. Viral contamination of embryos cryopreserved in liquid nitrogen. *Cryobiology* 2000; 40(2):110-6.
- Bielanski A, Bergeron H, Lau PC, Devenish J. Microbial contamination of embryos and semen during long term banking in liquid nitrogen. *Cryobiology* 2003; 46(2):146-52.
- Borini A, Bonu MA, Coticchio G, Bianchi V, Cattoli M, Flamigni C. Pregnancies and births after oocyte cryopreservation. *Fertility and Sterility* 2004; 82(3):601-5.
- Borini A, Cattoli M, Mazzone S, Trevisi MR, Nalon M, Iadarola I, et al. Survey of 105 babies born after slow-cooling oocyte cryopreservation. *Fertility and Sterility* 2007; 88 (Suppl. 1):S13–S14.
- Broekmans FJ, Visser JA, Laven JSE, Broer SL, Themmen APN, Fauser BC. Anti-Müllerian hormone and ovarian dysfunction. *Trends in Endocrinology and Metabolism* 2008; 19(9):340-7.
- Byskov AG, Faddy MJ, Lemmen JG, Andersen CY. Eggs forever? *Differentiation* 2005; 73:438-46.
- Center for Disease Control Report: <http://www.cdc.gov/ncbddd/birthdefects/facts.html>. Accessed August 2011.
- Chen C. Pregnancy after human oocyte cryopreservation. *Lancet* 1986; 1:884 – 6.
- Chian R, Huang JYJ, Gilbert L, Son W, Holzer H, Cui SJ, et al. Obstetric outcomes following vitrification of in vitro and in vivo matured oocytes. *Fertility and Sterility* 2008; 91(6):2391-8.
- Chian R, Huang JYJ, Tan SL, Lucena E, Saa A, Rojas A, et al. Obstetric and perinatal outcome of 200 infants conceived from vitrified oocytes. *Reproductive BioMedicine Online* 2008; 16(5):608-10.



- Cobo A, Kuwayama M, Perez S, Ruiz A, Pellicer A, Remohi J. Comparison of concomitant outcome achieved with fresh and cryopreserved donor oocytes vitrified by the CryoTop method. *Fertility and Sterility* 2008; 89(6):1657-64.
- Cobo A, Rubio C, Gerli S, Ruiz A, Pellicer A, Remohi J. Use of fluorescence in situ hybridization to assess the chromosomal status of embryos obtained from cryopreserved oocytes. *Fertility and Sterility* 2001; 75(2):354-60.
- Dolmans MM, Marinescu C, Saussoy P, Van Langendonck A, Amorim C, Donnez J. Reimplantation of cryopreserved ovarian tissue from patients with acute lymphoblastic leukemia is potentially unsafe. *Blood*. 2010; 116(16):2908 - 14.
- Donnez J, Dolmans MM. Cryopreservation of ovarian tissue: an overview. *Minerva Medica* 2009; 100:401 - 13.
- Donnez J, Dolmans MM, Demylle D, Jadoul P, Pirard C, Squifflet J, et al. Livebirth after orthotopic transplantation of cryopreserved ovarian tissue. *Lancet* 2004; 364(9443):1405-10.
- Donnez J, Silber S, Andersen CY, Demeestere I, Piver P, Meirow D, et al. Children born after autotransplantation of cryopreserved ovarian tissue. A review of 13 live births. *Annals of Medicine* 2011; 43:437-50.
- Dunson DB, Baird DD, Colombo B. Increased infertility with age in men and women. *Obstetrics and Gynecology* 2004 Jan;103(1):51-6.
- Eichenlaub-Ritter U, Shen Y, Tinneberg HR. Manipulation of the oocyte: possible damage to the spindle apparatus. *Reproductive BioMedicine Online* 2002; 5(2):117-24.
- Eroglu A, Russo MJ, Bieganski R, Fowler A, Cheley S, Bayley H, et al. Intracellular trehalose improves the survival of cryopreserved mammalian cells. *Nature Biotechnology* 2000; 18:163-7.
- Ezcurra D, Rangnow J, Craig M, Schertz J. The Human Oocyte Preservation Experience (HOPE) a phase IV, prospective, multicenter, observational oocyte cryopreservation registry. *Reproductive Biology and Endocrinology* 2009; 7:53.
- Fabrizi R, Porcu E, Marsella T, Rocchetta G, Venturoli S, Flamigni C. Human oocyte cryopreservation: new perspectives regarding oocyte survival. *Human Reproduction* 2001; 16(3):411-6.
- Faddy MJ, Gosden RG, Gougeon A, Richardson SJ, Nelson JF. Accelerated disappearance of ovarian follicles in mid-life: implications for forecasting menopause. *Human Reproduction* 1992 Nov;7(10):1342-6.
- Fahy GM. Vitrification: a new approach to organ cryopreservation. *Progress in Clinical and Biological Research* 1986; 224:305-35.
- Flisser E, Sage CF, Uberti LM, Copperman K, Ezcurra D, Copperman AB. Trends in Oocyte Cryopreservation - Local and National Economy on Elective Medical Procedures. *Fertility and Sterility* 2009; 92(3 Supp 1):S134.
- Frank Sage CF, Kolb BA, Treiser SL, Silverberg KM, Barritt J, Copperman AB. Oocyte Cryopreservation in Women Seeking Elective Fertility Preservation: A Multi-Center Analysis. *Obstetrics and Gynecology* 2008; 114(Supp 4):20S.
- Gibreel A, Maheshwari A, Bhattacharya S, et al. Ultrasound tests of ovarian reserve; a systematic review of accuracy in predicting fertility outcomes. *Human Fertility* 2009; 12:95-106.

- Gold E, Copperman K, Witkin G, Jones C, Copperman AB. A Motivational Assessment of Women Undergoing Elective Egg Freezing for Fertility Preservation. *Fertility and Sterility* 2006; 86(3 Supp 1):S201.
- Gook DA, Edgar DH. Human oocyte cryopreservation. *Human Reproduction Update* 2007; 13(6):591-605.
- Gosden RG, Baird DT, Wade JC, Webb R. Restoration of fertility to oophorectomized sheep by ovarian autografts stored at -196°C. *Human Reproduction* 1994; 9(4):597-603.
- Grifo JA, Noyes N. Delivery rate using cryopreserved oocytes is comparable to conventional in vitro fertilization using fresh oocytes: potential fertility preservation for female cancer patients. *Fertility and Sterility* 2010; 93(2):391-6.
- Grujters MJG, Visser JA, Durlinger ALL, Themmen APN. Anti-Müllerian hormone and its role in ovarian function. *Molecular and Cellular Endocrinology* 2003; 211:85-90.
- Herrero L, Martínez M, Garcia-Velasco JA. Current status of human oocyte and embryo cryopreservation. *Current Opinion in Obstetrics and Gynecology* 2011; 23(4):245-50.
- Hoffman DI, Zellman GL, Fair CC, et al. Cryopreserved embryos in the United States and their availability for research. *Fertility and Sterility* 2003; 79(5):1063-9.
- Hvidtfeldt UA, Gerster M, Knudsen L, Keiding N. Are low Danish fertility rates explained by changes in timing of births? *Scandinavian Journal of Public Health* 2010; 38(4):426-33.
- Jain JK, Paulson RJ. Oocyte cryopreservation. *Fertility and Sterility* 2006; 86(Suppl 3):1037-46.
- Johnson J, Canning J, Kaneko T, Pru JK, Tilly JL. Germline stem cells and follicular renewal in the postnatal mammalian ovary. *Nature* 2004; 428:145-50.
- Jones KT. Meiosis in oocytes: predisposition to aneuploidy and its increased incidence with age. *Human Reproduction Update* 2008; 14(2):143-58.
- Kolibianakis EM, Venetis CA, Tarlatzis BC. Cryopreservation of human embryos by vitrification or slow freezing: which one is better? *Current Opinion in Obstetrics and Gynecology* 2009; 21(3):270-4.
- Kuleshova L, Gianaroli L, Magli C, Ferraretti A, Trounson A. Birth following vitrification of a small number of human oocytes: case report. *Human Reproduction* 1999; 14:3077-9.
- Kuwayama M, Vajta G, Kato O, Leibo SP. Highly efficient vitrification method for cryopreservation of human oocytes. *Reproductive BioMedicine Online* 2005a; 11(3):300-8.
- Kuwayama M, Vajta G, Leda S, Kato O. Comparison of open and closed methods for vitrification of human embryos and the elimination of potential contamination. *Reproductive BioMedicine Online* 2005b; 11:608-14.
- La Marca A, Broekmans FJ, Volpe A, Fauser BC, Macklon NS. Anti-Müllerian hormone (AMH): what do we still need to know? *Human Reproduction* 2009; 24(9):2264-75.
- Luna M, Barritt J, Sage CF, Jones C, Howard M, Copperman AB. Oocyte Cryopreservation Survey: Health Care Providers' Recommendations. *Fertility and Sterility* 2008; 89(Supp2):S21-22.
- Maltaris T, Beckmann MW, Dittrich R. Fertility preservation for young female cancer patients. *In vivo* 2009; 23:123-30.
- Nagy ZP, Chang CC, Shapiro DB, Bernal DP, Elsner CW, Mitchell-Leef D, et al. Clinical evaluation of the efficiency of an oocyte donation program using egg cryo-banking. *Fertility and Sterility* 2009; 92(2):520-6.

- Noyes N, Boldt J, Nagy ZP. Oocyte cryopreservation: is it time to remove its experimental label? *Journal of Assisted Reproduction and Genetics* 2010; 27:69-74.
- Noyes N, Knopman J, Labella P, McCaffrey C, Clark-Williams M, Grifo J. Oocyte cryopreservation outcomes including pre-cryopreservation and post-thaw meiotic spindle evaluation following slow cooling and vitrification of human oocytes. *Fertility and Sterility* 2010; 94(6):2078-82.
- Noyes N, Porcu E, Borini A. Over 900 oocyte cryopreservation babies born with no apparent increase in congenital anomalies. *Reproductive BioMedicine Online* 2009; 18(6):769-76.
- Oktaý K. Evidence for limiting ovarian tissue harvesting for the purpose of transplantation to women younger than 40 years of age. *Journal of Clinical Endocrinology and Metabolism* 2002; 87(4):1907-8.
- Oktaý K, Cil AP, Bang H. Efficiency of oocyte cryopreservation: a meta-analysis. *Fertility and Sterility* 2006; 86:70 - 80.
- Oktaý K, Cil AP, Zhang J. Who is the best candidate for oocyte cryopreservation research? *Fertility and Sterility* 2010; 93(1):13-15.
- Oktaý K, Economos K, Kan M, Rucinski J, Veeck L, Rosenwaks Z. Endocrine function and oocyte retrieval after autologous transplantation of ovarian cortical strips to the forearm. *Journal of the American Medical Association* 2001; 286(12):1490-3.
- Oktaý K, Sönmezer M. Fertility preservation in gynecologic cancers. *Current Opinion in Oncology* 2007; 19:506-11.
- Pacchiarotti J, Maki C, Ramos T, Marh J, Howerton K, Wong J, et al. Differentiation potential of germ line stem cells derived from the postnatal mouse ovary. *Differentiation* 2010; 79:159-70.
- Palermo GD, Cohen J, Alikani M, Adler A, Rosenwaks Z. Intracytoplasmic sperm injection: a novel treatment for all forms of male factor infertility. *Fertility and Sterility* 1995; 63(6):1231-40.
- Parte S, Bhartiya D, Telang J, Daithankar V, Salvi V, Zaveri K, et al. Detection, characterization, and spontaneous differentiation in vitro of very small embryonic-like putative stem cells in adult mammalian ovary. *Stem Cells and Development* 2011; Epub ahead of print.
- Quintans CJ, Donaldson MJ, Bertolino MV, Pasqualini RS. Birth of two babies using oocytes that were cryopreserved in a choline-based freezing medium. *Human Reproduction* 2002; 17:3149-52.
- Renard JP, Babinet C. High survival of mouse embryos after rapid freezing and thawing inside plastic straws with 1-2 propanediol as cryoprotectant. *Journal of Experimental Zoology* 1984; 230(3):443-8.
- Rienzi L, Martinez F, Ubaldi F, Minasi MG, Iacobelli M, Tesarik J, et al. Polscope analysis of meiotic spindle changes in living metaphase II human oocytes during the freezing and thawing procedures. *Human Reproduction* 2004; 19(3):655-9.
- Schnorr J, Oehninger S, Toner J, Hsiu J, Lanzendorf S, Williams R, et al. Functional studies of subcutaneous ovarian transplants in nonhuman primates: steroidogenesis, endometrial development, ovulation, menstrual patterns and gamete morphology. *Human Reproduction* 2002;17(3): 612-9.
- Schorge JO, Schaffer JI, Halvorson LM, Hoffman BL, Bradshaw KD, Cunningham FG (Eds.). (2008). *Williams Gynecology*, The McGraw-Hill Companies, Inc., ISBN 978-0-07-147257-9, China.

- Scott RT Jr, Hofmann GE. Prognostic assessment of ovarian reserve. *Fertility and Sterility* 1995; 63(1):1-11.
- Shaw JM, Bowles S, Koopman P, Wood EC, Trounson OA. Fresh and cryopreserved ovarian tissue samples from donors with lymphoma transmit the cancer to graft recipients. *Human Reproduction* 1996; 11(8):1668 - 73.
- Singer T, Barad DH, Weghofer A, Gleicher N. Correlation of antimüllerian hormone and baseline follicle-stimulating hormone levels. *Fertility and Sterility* 2009; 91(6):2616-9.
- Smith GD, Serafini PC, Fioravanti J, Yadid I, Coslovsky M, Hassun P, et al. Prospective randomized comparison of human oocyte cryopreservation with slow-rate freezing or vitrification. *Fertility and Sterility* 2010; 94(6):2088-95.
- Society for Assisted Reproductive Technology  
[https://www.sartcorsonline.com/rptCSR\\_PublicMultYear.aspx?ClinicPKID=0](https://www.sartcorsonline.com/rptCSR_PublicMultYear.aspx?ClinicPKID=0).  
Accessed August 2011.
- Sowers MR, Eyvazzadeh AD, McConnell D, Yosef M, Jannausch ML, Zhang D, et al. Anti-Müllerian hormone and inhibin-B in the definition of ovarian aging and the menopause transition. *Journal of Clinical Endocrinology and Metabolism* 2008; 93(9):3478-83.
- Stachecki JJ, Cohen J, Willadsen SM. Cryopreservation of unfertilized mouse oocytes: the effect of replacing sodium with choline in the freezing medium. *Cryobiology* 1997; 37:346-54.
- Tan SL, Doyle P, Campbell S, Beral V, Rizk B, Brinsden P, et al. Obstetric outcome of in vitro fertilization pregnancies compared with normally conceived pregnancies. *American Journal of Obstetrics and Gynecology* 1992; 167(3):778-84.
- Trounson A, Mohr L. Human pregnancy following cryopreservation, thawing and transfer of an eight-cell embryo. *Nature* 1983; 305(5936):707-9.
- Wallace WHB, Kelsey TW. Human ovarian reserve from conception to the menopause. *PLoS ONE* 2010; 5(1):e8772.
- Wennerholm UB, Söderström-Anttila V, Bergh C, Aittomäki K, Hazekamp J, Nygren KG, et al. Children born after cryopreservation of embryos or oocytes: a systematic review of outcome data. *Human Reproduction* 2009; 24(9):2158-72.
- Whittingham DG, Leibo SP, Mazur P. Survival of mouse embryos frozen to -196 degrees and -269 degrees C. *Science* 1972; 178(59):411-4.
- Willett LL, Wellons MF, Hartig JR, Roenigk L, Panda M, Dearinger AT, et al. Do women residents delay childbearing due to perceived career threats? *Academic Medicine* 2010; 85(4):640-6.
- Zou K, Yuan Z, Yang Z, Luo H, Sun K, Zhou L, et al. Production of offspring from a germline stem cell line derived from neonatal ovaries. *Nature Cell Biology* 2009; 11(5):631-6.

# Cryopreservation of Testicular Tissue

Ali Honaramooz  
University of Saskatchewan  
Canada

## 1. Introduction

Immediate use of freshly collected testis tissue in diagnosis or in reproductive technologies is not always possible or desirable. Therefore, the ability to properly preserve the tissue for varying intervals is an essential step for maximizing the use of the source tissue. Preservation of gametes and gonads is a topic of interest in reproductive biomedicine. Other chapters in this book have elegantly covered current knowledge on the cryopreservation of sperm, oocytes, and early embryos as well as ovarian tissue, among other cells and tissues. However, the main objective of this chapter is to provide a focused discussion of the importance, methodology, potential applications, and limitations for applying cryopreservation to testicular tissue.

Cryopreservation of human testis tissue obtained by biopsy can be used as a potential future source of sperm. For adult cancer survivors whose only source of sperm is the testis parenchyma, cryopreservation of testis biopsies may be the only option remaining if they prefer to father their own biological progeny. This will require detection of sperm in frozen-thawed cell suspensions of testis tissues for use in intra-cytoplasmic sperm injection (ICSI). More importantly, cryopreservation of immature testis biopsies can offer a unique alternative for prepubertal boys undergoing gonadotoxic cancer treatments, whose only future source of spermatogenesis (*i.e.*, spermatogonial stem cells) is at risk. These strategies can also be applied to genetic preservation of endangered species/breeds through the cryopreservation of testis tissue from young animals that die prior to reaching maturity. Restoring the developmental potential of testis tissue after cryopreservation may also provide insight into proper banking of other immature tissues.

The effects of cryoprotectant concentration and cooling rate are not similar among tissues or species. Therefore, we will discuss the basis for a number of successfully applied strategies and workable protocols that have been used to effectively cryopreserve testis tissue in various species.

In summary, this chapter provides an overview of the current literature and contributions by the author and colleagues on cryopreservation of testicular tissue and its potential applications in experimental and clinical settings in reproduction medicine.

### 1.1 Developmental changes in the structure of testis tissue

In mammals at birth, all organs/tissues required for sustaining life display functional competence and histological similarity to those in mature individuals. Reproductive tissues,

on the other hand, attain maturity much later and only when other bodily requirements of parenthood are also in place. Therefore, in discussion of testis tissue cryopreservation, the developmental stage of the tissue is an important factor to be considered. For instance, for cryopreservation of testis tissue from an immature individual, the differing tissue texture and need for maintaining its future developmental potential are to be taken into account.

Embryonic development of the testis begins when the SRY gene in a genetic male is expressed, driving the transformation of an indifferent early gonad to a testis. This in turn causes differentiation of Sertoli cells to enclose the fetal germ cells, to mark the differentiation of primordial germ cells into gonocytes, and results in the formation of seminiferous cords. In humans, this process begins at 7-9 wk gestation (Wilhelm et al., 2007) and is immediately followed by differentiation of fetal Leydig cells, located in the interstitial spaces between the seminiferous cords, to allow production of testosterone thus causing masculinization of the foetus (Scott et al., 2009).

In early postnatal humans and most domestic species, the testis still contains interstitial tissue and seminiferous cords, with gonocytes as the only type of germ cells present (Franca et al., 2000). Initially, gonocytes reside in the centre of the seminiferous cords (Fig. 1A), but they gradually migrate toward the periphery of the cords and remain in close contact with Sertoli cells and peritubular myoid cells at the basement membrane to form the stem cell niche (Pelliniemi, 1975; Van Straaten & Wensing, 1977). Gonocytes eventually give rise to spermatogonial stem cells (SSCs), which have the ability to both self-renew and give rise to differentiating germ cells. Postnatal development of the testis also involves proliferation and maturation of Sertoli cells to transform testicular cords into seminiferous tubules (containing a lumen), followed by sequential division and differentiation of germ cells to generate sperm (Fig. 1B) (Hughes & Varley, 1980; Ryu et al., 2004). Therefore, SSCs form the foundation of spermatogenesis and are responsible for a lifetime supply of sperm.

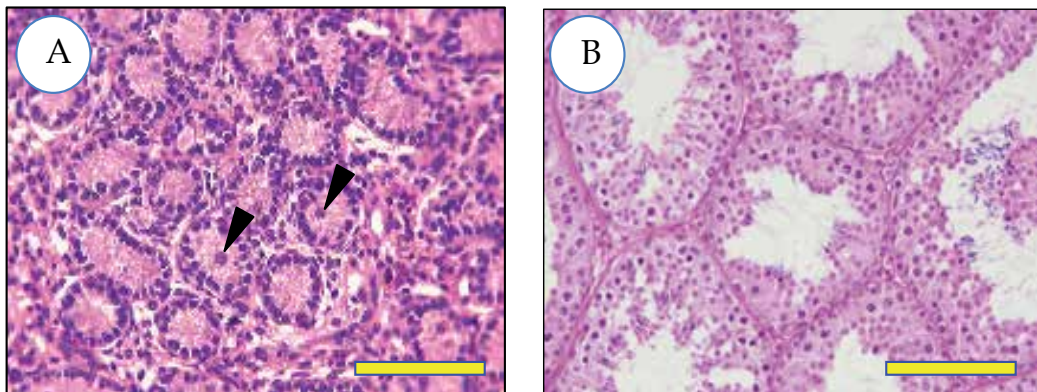

Fig. 1. Histological differences between an immature and a mature testis tissue. In the immature testis (A), seminiferous cords contain only one type of germ cells - gonocytes (arrow heads). In the mature testis (B), on the other hand, seminiferous tubules are much larger in diameter, contain a lumen, and a repertoire of germ cell types. The composition and extent of the interstitial tissue also changes over development. These differences may affect the response of the tissue to a given cryopreservation protocol even within the same donor species. Scale bar = 100 mg. Images modified from Abbasi & Honaramooz (2011).

As highlighted in **Figure 1**, the cellular composition of a typical mature testis is quite different from that of an immature testis; for instance, the latter hosts a considerably higher number of differentiating germ cells, known to be more sensitive to manipulations and temperature changes (Franca et al., 2000; Frankenhuys et al., 1981). Consequently, the tissue composition of the testis changes during development and proportionally larger volumes of the mature testis are occupied by the seminiferous tubules. Therefore, the developmental state of the testis affects the tissue composition and has important implications for its cryopreservation.

## 2. Rationale for preserving testis tissue from human and animal donors

Preservation of testicular tissue could be pursued for multiple reasons. An estimated 1 in 650 children will be diagnosed with malignancies by age 16, of which 80% will be cured (Stiller et al., 2006). However, irreversible gonadotoxic insult of chemo/radio-therapy remains a major concern in the use of these life-saving treatments, which render about 20% of boys sterile in the long term, likely as a result of the loss of spermatogonial stem cells (Apperley & Reddy, 1995; Naysmith et al., 1998). With improved treatments, the proportion of childhood cancer survivors is expected to increase, posing an even greater challenge for reproductive medicine and oncologist practitioners in the decades to come. A routine strategy to offer preservation of future fertility for adult men undergoing sterilizing cytotoxic treatments is to freeze semen samples; however, some men may be azoospermic at the time of cancer diagnosis. More critically, in pre-adolescent boys, collection of sperm is not possible because spermatogenesis has not yet started. In such cases, cryopreservation of testicular biopsies collected prior to the start of the treatment may provide a potential source for future use in emerging reproductive technologies.

In animal conservation, preventing the permanent loss of a male's potential contribution to the genetic variability of a rare or endangered species/breed is feasible through the collection of sperm before or even shortly after death by retrieval from the ejaculate, epididymis, or testes, which is then cryopreserved for future use in assisted reproduction (Gañán et al., 2009; Kishikawa et al., 1999; Martínez et al., 2008; Maksudov et al., 2009). Preservation of sperm, however, is not an option when young offspring die prior to reaching sexual maturity. Cloning has been used for a number of species and especially where the goal has been to produce a genetically exact replica of an individual animal. However, development of cloning for a new species is technically demanding and costly but, more importantly, does not immediately provide the genetic diversity that would otherwise be offered by gametes. In such cases, cryopreservation of testicular tissue can again provide an alternative strategy for *ex situ* generation of sperm from these neonatal/immature animals for use in reproductive technologies (Abbasi & Honaramooz, 2011).

## 3. Methodology for cryopreservation of testicular tissue

A number of cryogenic strategies have been developed to serve as a means to maintain functional properties of the preserved cells and tissues. Apparently, the first successful cryopreservation of cells was carried out by accidental freezing of fowl sperm in diluents containing glycerol (Polge et al., 1949). Later, cryopreservation of bull sperm using glycerol (Polge & Lovelock, 1952; Smith, 1961), set the stage for revolutionizing the bovine artificial

insemination industry. At about the same time, cryopreservation of unfertilized oocytes was also studied following exposure to glycerol and low temperatures (Smith, 1952). After initial success with *in vitro* embryo manipulation in the 1950s (McLaren & Biggers, 1958), research involving embryo freezing intensified. Many methods have now been developed for embryo cryopreservation and, since the 1980s, some have become routine procedures (Whittingham et al., 1972; Whittingham, 1977; Wilmut, 1972). Cryopreservation of mature oocytes has also been achieved (Fabbri et al., 2001; Porcu, 2001; Porcu et al., 1997), with high survival rates and development of normal pregnancies after *in vitro* fertilization (IVF).

Cryopreservation of structurally intact tissues in certain situations is more desirable than cryopreservation of isolated cells. This is especially important for complex tissues in which preservation of the target cells' functionality depends on that of other cell types present within the tissue. In case of testicular tissue, not only germ cells but also the intra-tubular supporting - Sertoli - cells as well as androgen producing interstitial - Leydig - cells are of particular interest. However, this requires devising suitable freezing protocols to maintain the existing relationship among different compartments of the tissue.

The first gonadal tissue to be successfully cryopreserved was ovarian tissue, using exposure to glycerol, resulting in preservation of cell viability and normal function after being autografted back into the animals (Deanesly, 1954; Green et al., 1956; Parkes, 1958). Subsequent reports of live rat offspring, sheep ovarian cyclic function, and pregnancy after grafting cryopreserved ovaries represented important steps in demonstrating the feasibility of this approach (Gosden et al., 1994; Parrot, 1960). Restoration of spermatogenesis was then obtained after cryopreserved testis cells were transplanted into recipient testes (Avarbock et al., 1996; Brinster & Nagano, 1998; Ogawa et al., 1999).

Cryopreservation of testicular tissue to be used as tissue *per se*, however, was not widely considered, perhaps due to lack of its potential applications. This need changed when we and others were first to show that cryopreservation of immature testis tissue prior to its xenografting can be done so as to maintain its potential for development of complete spermatogenesis (Honaramooz et al., 2002a; Schlatt et al., 2002). In a short period of time since then, major advances in cryopreservation of testicular tissue have opened new possibilities for preservation of male fertility in animals and humans. More recently, induction of complete spermatogenesis *in vitro* has further highlighted the importance of applying cryopreservation to testicular tissue for future applications. Overall, major advances have been made in the cryopreservation of reproductive tissues. The following sections review the primary contributing factors to be considered for optimal cryopreservation.

### 3.1 Biophysics of cryopreservation

A clear understanding of biophysical behaviour of cells at the time of freezing and exposure to different cryoprotectants is critical in providing conditions to improve the cell structural and functional potential after freezing-thawing. During slow rate of cooling, extracellular ice crystal formation begins with the presence of a nucleation site in the extracellular medium. Because ice is pure crystalline water, the extracellular space becomes hypertonic due to the removal of water as ice crystals develop. Intracellular water, therefore, moves outward across the cell membrane due to the differential osmotic gradient, and cells dehydrate and shrink. This is the opportunity when certain cryoprotective compounds come into play,



permeating the cells and protecting them against high solute concentration or ice crystal damage. Because various cryoprotectant agents (CPAs) permeate different cell types at varying rates, it is of benefit to understand the biophysics of cryopreservation to minimize damage (Fuller & Paynter, 2004; Pegg, 2007).

### 3.2 Freezing injuries

Two main rival theories have been proposed to explain cell damages due to freezing. One emphasizes the direct and primarily mechanical damage to live cells by ice crystals puncturing through the cell membranes, and the other highlights the secondary effects of ice formation via osmotic changes. Perhaps, both mechanisms are important and what is recently agreed upon is that for individual cells, for example those in suspensions, intracellular freezing is very hazardous, while the extracellular ice may not be as harmful (Pegg, 2007). Unlike cell suspensions, the cellular organization and structural composition of the tissue may be seriously affected by cryogenic damage through widespread extracellular ice formation (Hunt et al., 1982; Taylor & Pegg, 1983). Ice formation within a tissue, initiated in the extracellular space, leads to an osmotic gradient across the cell membranes, causing intracellular water to move toward the concentrated extracellular space surrounding the cells (Bagchi et al., 2008; Fuller, 2004). Due to the differential destructive effects of extracellular ice formation between cell suspensions and complex tissues, conventional approaches to cryopreservation of cells, even testis cells for instance, may not necessarily be suitable for multicellular tissues such as the testis tissue. Optimal cooling rates for various cell and tissue types have been shown to differ and be directly associated with the degree of water permeability of cell membranes at different temperatures during freezing (Leibo et al., 1970; Mazur, 1990; Pegg, 2007).

When extracellular ice formation causes elevated solvent concentrations, it leads to cell dehydration; prolonged exposure to which can permanently damage cell membranes and destabilize proteins (Fuller, 2004). However, short exposure of cells to optimized concentrations of hypertonic media before freezing might protect them from retention of supercooled water within cells and subsequent crystallization during freezing (Fuller, 2004). When cooling is faster than optimal, intracellular ice formation could occur due to inadequate time for water to follow the osmotic gradient across the cell membrane (Fuller, 2004; Fuller & Paynter, 2004; Pegg, 2007). The osmotic tolerance of cells is another critical factor to be considered during addition and removal of different cryoprotectants. Physical destruction, subsequent organelle disruption, and functional damage are some of the known consequences of ice crystal formation (Mazur, 2004).

### 3.3 Protection mechanism and toxicity of cryoprotectants

Sufficient concentration of cryoprotectants could minimize ice crystallization and/or promote amorphous solidification (vitrification). Glycerol was introduced as a CPA in 1949 (Polge et al., 1949) and, a decade later, cryoprotective properties of dimethyl sulfoxide (DMSO) were also reported (Lovelock & Bishop, 1959). These two cryoprotectants have mainly been used since then as classic cryoprotective additives, although many other CPAs have been introduced. Permeating CPAs, such as DMSO, glycerol, methanol, propanediol, ethylene glycol, and dimethyl acetaldehyde, as well as non-permeating CPAs, including sucrose, dextran, albumin, polyvinyl pyrrolidone, and hydroxyethyl starch, have also been shown to afford effective cryoprotection (Bagchi et al., 2008; Fuller, 2004).

Cryoprotective agents are known to act through different pathways to protect cells against freezing injuries. This includes modulation of hydrogen bonding and interaction with water molecules, which give CPAs solubility and high permeability across cell membranes (Fuller, 2004). As a second mechanism, CPAs may provide a salt-buffering effect. During freezing, cells experience osmotic dehydration and shrinkage; therefore, the addition of CPAs into the cells maintains salt dilution. Basically, the CPA replaces water in cells, which dilutes the intracellular salts and prevents intracellular crystal formation. The amount of CPAs and water that permeates into the cells depends on the concentration of permeable solutes and the final cell volume. The properties of CPAs and those of cell membranes will influence the degree of cryoprotection for different cell types (Fuller, 2004; Fuller & Paynter, 2004). A third potential pathway is the stabilization of biomembrane critical macromolecules. Under normal conditions, water stabilizes the membrane bilayers. Loss of water during cryopreservation may disrupt normal membrane permeability and damage the membrane itself. The CPAs stabilize proteins as well as phospholipid bilayers of cell membranes and help to protect the membrane against freezing and dehydration stresses (Crowe, et al., 1990). Studies have collectively demonstrated that CPAs, including DMSO and disaccharide sugars such as sucrose and trehalose, may electrostatically interact with membrane phospholipids to provide stabilization (Anchordoguy et al., 1987; Rudolph & Crowe, 1985). The fourth mechanism by which CPAs protect the cells and tissue is through scavenging oxygen free radicals and preventing oxidative stress to the cells (Fuller, 2004). CPAs block the action of unstable intermediate products, such as oxygen free radicals, by binding their hydrogen atoms to them (Benson, 2004; Fleck et al., 2000). The fifth possible pathway for the protective effects of CPAs is the inhibition of nucleation, through which ice formation occurs in the media. During cooling, initial heterogeneous nucleation sites, such as small particles, change in shape and increase in size within media, eventually reaching a stage that forms ice crystals. Alternatively, induced nucleation could be beneficial to provide consistent extracellular crystallization. This phenomenon is the basis for "seeding", which induces nucleation onto supercooled media enabling proper cryopreservation (Fuller, 2004). Seeding can be achieved by clamping the side of vials or straws with a forceps cooled in liquid nitrogen to stimulate local ice growth in the solutions. Intracellular nucleation can also be lethal or damaging for cells and tissues. Some CPAs, such as DMSO or glycerol, inhibit nucleation by increasing the high viscosity of intracellular water (Fuller, 2004). Non-permeating CPAs, on the other hand, increase and promote cellular dehydration by increasing the extracellular solute concentration thereby reducing intracellular crystallization (Bagchi et al., 2008).

Despite the protective potential of CPAs, a side effect of their addition is cytotoxicity. Tissue tolerance to CPAs is limited and overexposure may cause damage (Pegg, 2002); however, measuring this toxicity is difficult to precisely assess (Fuller, 2004). Cytotoxicity is further exacerbated by increasing CPA concentrations during ice formation. Optimizing the freezing rate as well as the addition or removal of CPAs could reduce their toxicity (Pegg, 2002).

### **3.4 Choice of cryopreservation strategies**

For cryopreservation of testicular tissue, two popular strategies are slow freezing and vitrification. These techniques differ mainly in the concentration of CPAs used.

Cryopreservation of cells within intact tissues is obviously more demanding than for cells within suspensions. Theoretical differences include heterogeneity of cells, slower rates of solute diffusion, and heat exchange through the mass of a complex tissue. However, judging from evidence from other tissue types, if a sufficient concentration of CPAs is provided, finding a proper cooling rate can yield high survival for different cell types within the tissue (Pegg, 2007). Critical factors for effective cryopreservation, such as cell permeability to water or CPA and subsequent osmotic changes, are directly affected by the rate of cooling (Mazur, 1990). Therefore, finding the optimal cryopreservation protocol for testicular tissue of a particular species/maturational state depends on the application of a proper concentration of the cryoprotectant with a suitable cooling rate.

Slow (controlled) freezing is considered the conventional method for cryopreservation of testicular tissue, in which the CPA is used at low concentrations (usually 0.5 to 2 M) to minimize both cell damage and CPA toxicity. During slow freezing (*e.g.*,  $-1^{\circ}\text{C}/\text{min}$ ), the CPA is given a chance to slow down the formation of extracellular ice crystals (and prevent the intracellular ones) but especially to moderate the indirect solution effects as freezing proceeds. However, prolonged exposure to CPA before completion of cryopreservation can also cause cell toxicity (Fuller, 2004). On the other hand, if the cell is cooled more rapidly, then water will not leave the cells fast enough to avoid intracellular freezing, which is very damaging to the cells (Pegg, 2007). Using automated systems, freezing curves (Fig. 2) can be customized to maximize cell viability after cryopreservation of the tissue.

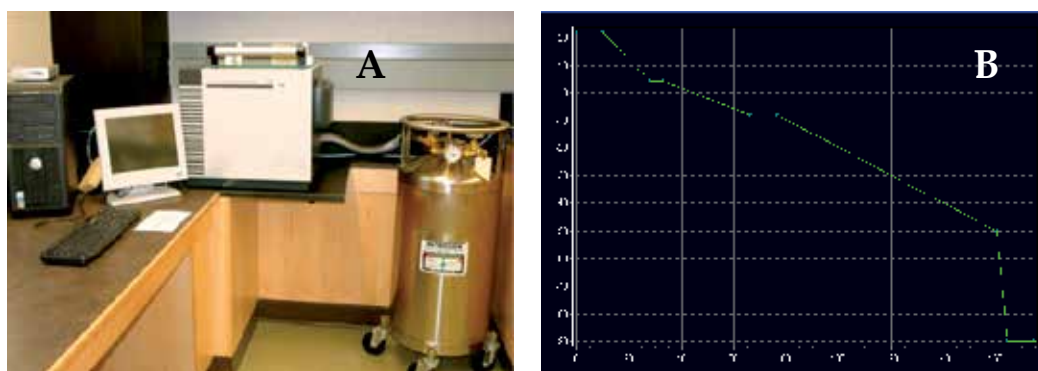

Fig. 2. A programmable automated freezing system. Although requiring larger capital investments, automated cell/tissue freezing systems (A), consisting of a freezing chamber attached to a computer and a liquid nitrogen tank, allow customization of the freezing curve (B) to achieve pre-defined temperatures (Y-axis) for desired lengths of time (X-axis), in an accurate and consistent manner.

As indicated earlier, the formation of extracellular ice, which may not pose a problem for freezing of cell suspensions, is likely the main problem for tissues. Therefore, an alternative route to avoid ice crystal formation and solute damage within the tissue is to avoid ice crystal formation altogether using transformation of aqueous milieu of the cell/tissue to the amorphous character of a glassy state, known as vitrification. Vitrification is a cryopreservation method in which ice crystal formation is prevented because the cells or tissues are exposed to very high concentrations of CPAs (*e.g.*, 5 to 8 M) and undergo ultra rapid freezing rates (*e.g.*, up to  $-2500^{\circ}\text{C}/\text{min}$ ) (Fuller, 2004; Pegg, 2002, 2007). However, this

approach is compromised by the cytotoxic effects of CPAs at such high concentration, especially with increased exposure times (Fuller, 2004; Fuller & Paynter, 2004). For small volumes of cell suspension, CPA concentrations can be reduced somewhat by using very rapid cooling and warming rates. However, especially with increasing size and complexity of the tissue, the limits of temperature exchange rates are more restricted, hence the use of very high concentrations of CPAs are unavoidable (Pegg, 2007). To overcome this problem, the use of a combination of CPAs to improve vitrification while reducing toxicity has been suggested. Proper media may include disaccharides, such as sucrose or trehalose, and proteins or polymers (Kasai & Mukaida, 2004; Sutton, 1992). The optimal CPA concentrations and exposure times to prevent toxicity must be specifically considered for each tissue type. (Fuller & Paynter, 2004; Pegg, 2007). We have used a solid-surface vitrification method to minimize the volume surrounding the tissue pieces, while avoiding liquid nitrogen (LN<sub>2</sub>) vapour formation and preventing direct contact with LN<sub>2</sub> to prevent potential contamination (Fig. 3, Abrishami et al., 2010a).

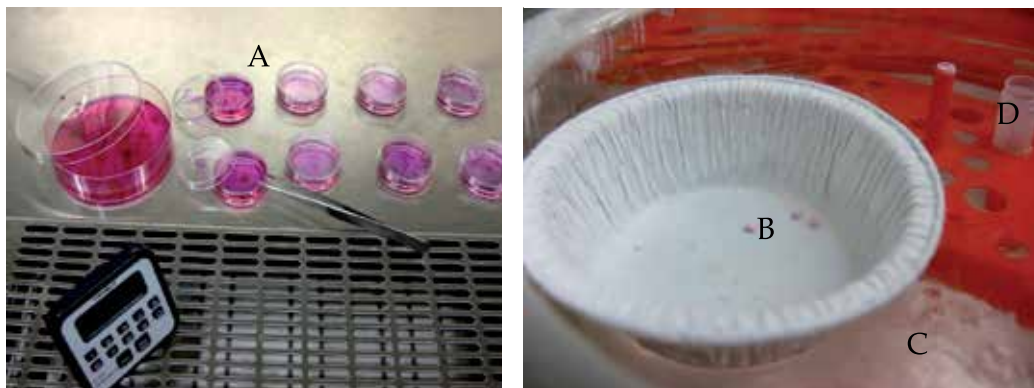

Fig. 3. Solid-surface vitrification procedure for testicular tissue fragments. After exposure of testis tissue fragments to differing concentrations of vitrification solutions for varying lengths of time (A), testis tissue fragments are placed on a sterile aluminum boat (B) floating on liquid nitrogen (C), then transferred into cooled cryovials (D) followed by plunging into liquid nitrogen (images modified from Abrishami, 2009).

### 3.5 Thawing methods

Whether freezing is permitted (conventional cryopreservation) or prevented (vitrification), the CPA that has reached the internal compartments of a multicellular system must diffuse back through numerous membranes in the tissue, with each acting as a barrier. Therefore, optimal thawing and CPA removal procedures are also critical factors for cell/tissue survival after freezing (Bagchi et al., 2008). Earlier studies pointed out that consistent cooling and thawing rates (slow-freezing followed by slow-thawing, or fast-freezing followed by fast-thawing) can improve cell/tissue survival after cryopreservation (Whittingham et al., 1972). Moreover, extreme osmotic changes during CPA removal might damage the cells by extensive cell shrinkage or swelling associated with the rapid movement of water into the cell as compared to the slower movement of the CPA out of the cell. However, a limited amount of water replacement is needed to restore osmotic equilibrium and physiologic cell volume (Pegg, 2007).

### 3.6 Post-thawing analysis

For successful cryopreservation of a complex vascularized tissue, such as testis tissue, the majority of essential cells need to be viable for the tissue to survive and retain its function. However, there is not yet a comprehensive and universally applied method for post-thawing analysis of cryopreserved testis tissue; subsequently, multiple approaches have been used to assess tissue/cell viability and extent of cryogenic injuries. These approaches commonly include histopathological examination of tissue sections for morphological changes. Using light microscopy, for instance, such objective criteria as seminiferous cord/tubular diameter or cell density within tubule cross sections can be measured, or semi-quantitative morphometric analyses applied to subjectively score such criteria as health or integrity of tissue compartments (Abrishami et al., 2010a; Curaba et al., 2011; Milazzo et al., 2008; Travers, et al., 2011). Transmitted electron microscopy, although not widely used, can be invaluable in the examination of subcellular components most likely to be affected by testis tissue cryopreservation, including cytoplasm integrity, nuclear membrane, and various organelles (Keros et al., 2007). Other valuable morphological analyses may include assessment of cell-specific changes, for example, using double-staining of proliferation markers (*e.g.*, Ki67) and MAGE-AH, vimentin, or CD34 for identification of spermatogonia, Sertoli cells, or peritubular cells, respectively (Keros et al., 2007; Wyns, et al., 2007).

A quantitative measure of tissue damage due to cytotoxicity after cryopreservation can be achieved through lactate dehydrogenase release assays (Curaba et al., 2011) or through viability assessment of dissociated cells after digestion of frozen-thawed tissues using Trypan blue exclusion assays or the various cell viability kits using a flow cytometer analyzer (Abrishami et al., 2010a; Gouk et al., 2011). Assessment of apoptosis, using for instance, caspase-3 (Wyns et al. 2008), or TUNEL assay for detection of DNA fragmentation provides insight into the extent of cell damage (Milazzo, et al., 2008). Detection of phosphatidylserine translocation from the inner to the outer layer of the plasma membrane, using fluorescent-labelled Annexin V, also allows more targeted assessment of apoptotic-associated changes within the cryopreserved testis tissue (Milazzo et al., 2008).

Having merely high cell survival rates or lacking visible damage does not guarantee functional preservation of the tissue as a whole. A thorough post-thawing analysis should include a form of testing for the functionality of the cryopreserved tissue. Post-thawing *in vitro* organotypic culture of the cryopreserved testis tissue has allowed assessment of its survival in the short-term (Curaba et al 2011; Keros et al., 2007) and measurement of its hormone release into culture media (Gouk et al., 2011). Perhaps more robust examination is provided by grafting, where the survival and developmental competence (both in terms of germ cell differentiation and androgen release) of the cryopreserved tissue *in vivo* as grafts allows a longer-term functional assessment (Abrishami et al., 2010a; Jahnukainen et al., 2007; Wyns et al., 2007).

### 3.7 Effects of tissue size

To offer cryoprotection, the CPAs need to diffuse rapidly in and out of the tissue; therefore, the size of testis tissue samples undergoing cryopreservation can be an important intuitive consideration. The results of studies differ depending not only with respect to the donor species but also potentially on the protocols employed. For instance, while cryopreservation of immature rat testis using similar procedures demonstrated better results for 7.5 mg pieces than 15 mg pieces (Travers et al., 2011), cryopreservation of immature mouse testis using

whole testes with punctured tunica albuginea was deemed more suitable than using whole testes with intact tunica, whole testes without tunica, or testis halves (Gouk et al., 2011). Mouse testes have considerably less connective tissue content than most other species; therefore, tissue fragment size is especially a concern for testis tissues from species with higher interstitial tissue density. For cryopreservation of (cryptorchid) testes from prepubertal boys, fragments sizes of 2-9 mm<sup>3</sup> were used successfully (Wyns et al., 2007). We also reported that immature porcine testis tissues undergoing the same cryopreservation treatments were not affected by the original size of the testis tissue fragment (5, 15, 20, or 30 mg) (Abrishami et al., 2010a). Although not used for cryopreservation, no effect of tissue sample size was observed for one-wk old piglet testes (as intact or fragments of 100 or 30 mg) when used for hypothermic preservation for 6 days (Yang et al., 2010). It remains to be seen if whole human testes can be cryopreserved as has been accomplished for whole ovaries (Courbiere et al., 2006; Jadoul et al., 2007; Martinez-Madrid et al., 2007).

#### **4. Applications of testis cryopreservation for new reproductive technologies**

Given that properly cryopreserved testis biopsies can last decades in liquid nitrogen and that most prepubertal cancer patient boys donating biopsies may not need to resort to assisted reproductive technologies for a couple of decades, it is advisable that cryopreservation of testicular biopsies be offered to such patients in a hope that our ability to use such tissues will be further improved and the options expanded in the coming years.

A number of potential applications already exist for the use of cryopreserved testicular tissue in experimental and clinical settings in reproduction medicine/science. Such technologies allow retrieval of existing sperm from mature donor samples and, more importantly, offer hope for production of sperm in samples of cryopreserved testis immature testis. If the preserved testis tissue contains endogenous spermatogenesis (*e.g.*, from obstructive azoospermic adult patients), it can be used to extract sperm, elongated spermatids, or even round spermatids to be used for fertilization of oocytes through ICSI (Rosenlund et al., 1998; Schrader et al., 2002; Gianaroli et al., 1999; Tesarik et al., 2000; Schoysman et al., 1999).

If preserved testis samples are obtained from neonatal/immature donors, they can still be used to induce spermatogenesis through the following approaches.

##### **4.1 Germ cell transplantation**

The technique for germ cell transplantation has allowed (re)establishment of spermatogenesis after introduction of donor testis cell suspensions into the seminiferous tubules of infertile recipient testes. Once deposited in the tubular lumen, donor SSCs are recognized by the host Sertoli cells and allowed passage to the stem cell niche, where new colonies of spermatogenesis can begin and expand. This approach has allowed production of sufficient numbers of sperm to allow infertile recipient mice to sire donor-derived progeny (Avarbock & Brinster, 1994; Brinster & Zimmermann, 1994). Later, the capability of cryopreserved mouse testis cells after transplantation into recipient testes to start spermatogenesis was also confirmed (Avarbock et al., 1996; Brinster & Nagano, 1998; Ogawa et al., 1999). While heterologous transplantation of human germ cells into recipient mice did not lead to completion of spermatogenesis (Nagano et al., 2002), the transfer technique has been tested

using human testes (Schlatt et al., 1999; Brook et al., 2001). Although autologous/homologous transplantation of germ cells for humans is currently considered purely experimental, one possibility for prepubertal human testis samples taken and frozen prior to treatments is to isolate testis cells and transfer them back to the individual. As a major problem with this approach is the risk of reseeding a systemic cancer, solutions to this (e.g., soring out tumour cells) and other safety issues are under investigation.

We have expanded the technique for germ cell transplantation into farm animals (**Fig. 4**), showed the feasibility of SSC engraftment in unrelated recipient individuals (of the same species) without a need for immune-suppression, and further demonstrated the applicability of the approach through donor-derived sperm production by the recipients and birth of progeny carrying the donor characteristics (Honaramooz et al., 2002b 2003a, 2003b; Honaramooz & Yang, 2011). Therefore, although experimental at this stage, the approach may offer promise in salvaging genetic material from cryopreserved testicular tissue from immature endangered species.

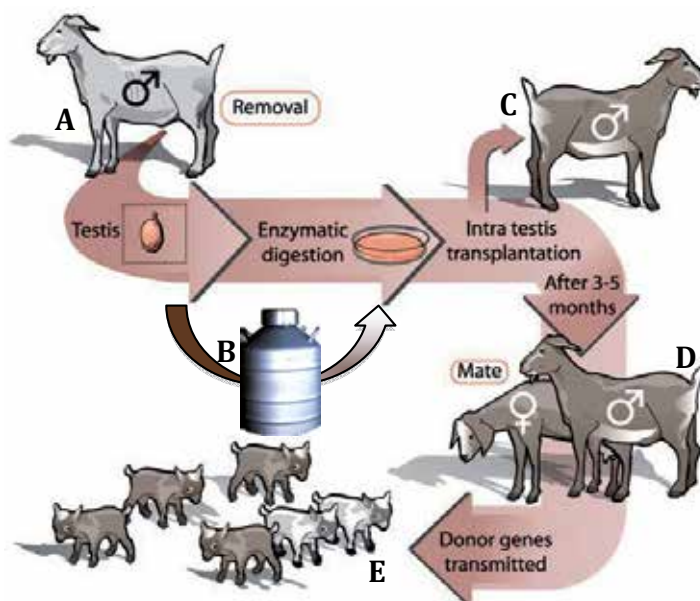

Fig. 4. Schematic overview of germ cell transplantation from a donor male into the testes of a recipient. The testes are collected from a donor animal (A), which could theoretically include post-mortem testis recovery from a recently deceased juvenile individual of an endangered species. The testis tissue could be cryopreserved (B) until conditions for its use are in place. At the time of transplantation, a single-cell suspension is prepared and the cells are infused into the seminiferous tubules of a recipient animal (C). Mating of the recipient (D) produces progeny (E), some of which will carry the donor genome (image modified from Honaramooz et al., 2003b).

#### 4.2 Testis tissue (xeno)grafting

Another potential strategy for the use of cryopreserved testis tissue is represented by testis tissue xenografting. Grafting of both fresh and cryopreserved testis tissue fragments from

donors of different species under the back skin of recipient mice results in the production of functional sperm (Honaramooz et al., 2002a). The approach has especially been successful using neonatal/immature donors (Fig. 5), from laboratory animals to domestic animals, primates, and even humans (Honaramooz et al., 2002a, 2004, 2008; Schlatt et al., 2002; Oatley et al., 2004; Snedaker et al., 2004; Rathi et al., 2005, 2006; Arregui et al., 2008; Abrishami et al., 2010b).

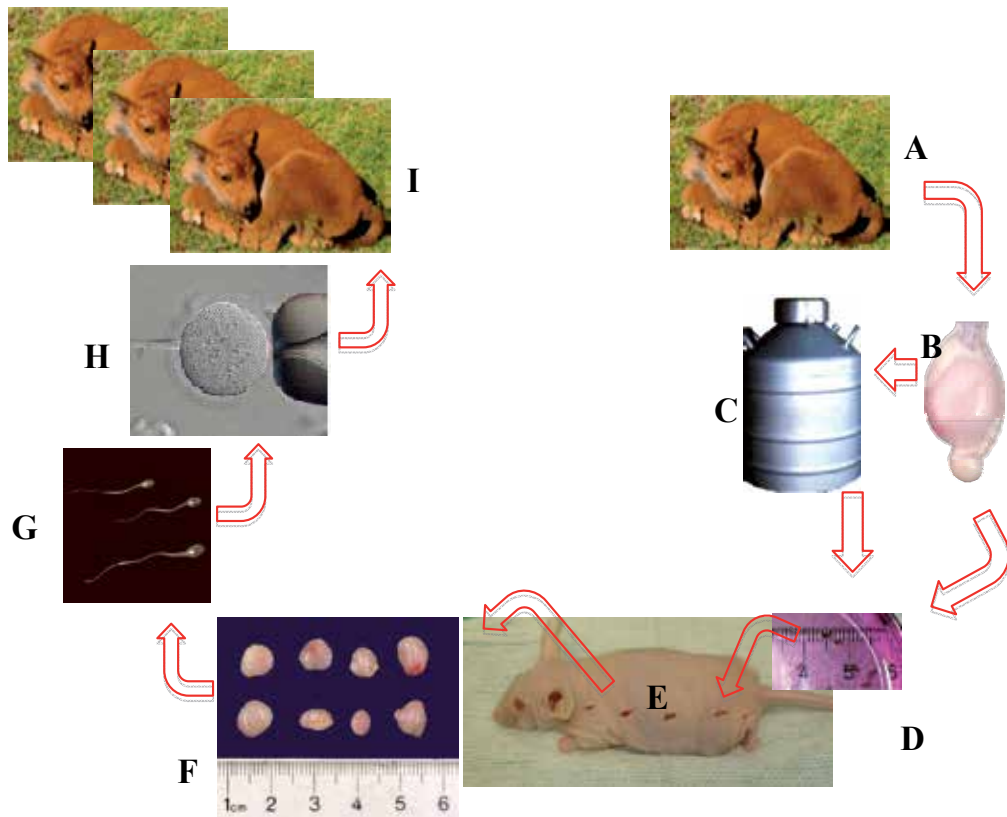

Fig. 5. Schematic representation of testis tissue (xeno)grafting from an immature donor individual into the back skin of a host mouse. The testes are collected from a donor animal (A), which could include post-mortem testis recovery from a recently deceased newborn animal of an endangered species. The testis tissue (B) could be cryopreserved (C) until grafting. At the time of grafting, tissue fragments of  $\sim 0.5 \text{ mm}^3$  (D) are prepared and the fragments are grafted subcutaneously into an immunodeficient host mouse (E). When given enough time, the grafts can grow in size (F) and undergo development, leading to the production of complete spermatogenesis, including fertilization-competent sperm (G). The sperm can then be extracted from the grafts and used in intracytoplasmic sperm injection (ICSI) (H), which after embryo transfer can potentially lead to birth of progeny (I).

The sperm recovered from such grafts, including those from primates, have been shown to be fertilization competent after ICSI (Honaramooz et al., 2002a, 2004, 2008), leading to the birth of healthy progeny (Schlatt et al., 2003; Nakai et al., 2010). We recently showed that testes recovered post-mortem from newborn bison calves, as a model for closely-related rare



or endangered ungulates can be used for this application, and when allowed to develop in the host mouse, lead to full spermatogenesis (Abbasi & Honaramooz, 2011). Therefore, testis tissue xenografting can be used as unique solution for genetic conservation of immature males by producing sperm from these otherwise resource-less donors in xenografts, followed by extraction and cryopreservation of sperm for future use in ICSI (Fig. 5).

However, xenografting of human gonadal tissues into animals to harvest the resultant gametes for use in IVF for humans is prohibited in Canada, and possibly in other countries, due to the potentially serious risk of animal viral transmission or contamination with animal genetics. Nevertheless, the promising results from animal research suggest a potential hope for future use of cryopreserved testis biopsies from pre-adolescent boys to be grafted back to the individual; whether this technique can be used to produce viable sperm for future use from prepubertal boys undergoing gonadotoxic treatments remains to be determined. However, the same safety risks as for autologous germ cell transplantation exist and require addressing before such an option can be offered clinically.

#### **4.3 *In vitro* maturation of germ cells**

In theory, cryopreserved testicular tissues can also be used for *in vitro* induction of differentiated germ cells and ideally production of sperm or spermatids to be used for ICSI. If successful, this approach can circumvent the potential risk of reintroducing cancer cells into post-recovery patients. Many labs have experimented with the idea, and some have had success with maturation of later stages of human spermatogenesis (but not from SSCs), including live births (Tesarki et al., 1999). Availability of a culture system to support complete *in vitro* spermatogenesis from the SSC stage was, however, elusive until very recently when it was reported that all spermatogenic lineage cells including fertilization-competent sperm could be produced from neonatal mouse testes maintained exclusively in a culture system (Shinohara et al., 2011). This is a very promising step, indicating that similar results may be achievable in future using immature human testis biopsies.

### **5. Current trends in testis tissue cryopreservation**

Since the first reports of successful germ cell transplantation and xenografting of testis tissue raised new interest in this field, several promising cryopreservation protocols have been introduced. Perhaps not surprisingly, the results differed and at times conflicted depending on the tissue donor species/developmental stage. These first reports of cryopreservation of pig and mouse testis tissues were based on DMSO-based slow freezing protocols originally developed for isolated testis cells or for ovarian tissue, respectively (Honaramooz et al., 2002a; Schlatt et al., 2002). Later, other detailed studies comparing multiple protocols showed high cell viability with programmed slow-freezing of immature mouse testis tissue using 1.5M DMSO as a cryoprotectant (Milazzo et al., 2008; Traverse et al., 2011). DMSO has also been found to be a more suitable cryoprotective agent than ethylene glycol for immature mouse and rat testis tissue (Goossens et al., 2008; Jezek, 2001). Shinohara et al. (2002) reported the birth of mouse offspring from sperm retrieved from cryopreserved pre-pubertal testis tissue with DMSO after transplantation under tunica albuginea of the recipient testes (Shinohara et al., 2002). Similar results were obtained using primate testis tissue, where 1.4M (but not 0.7M) DMSO was able to protect some of the developmental potential of grafts from rhesus monkeys (Jahnukainen et al., 2007) but the 0.7M DMSO protocol was successful for cryopreservation of

human testis tissue (Wyns et al., 2007) at one age/developmental stage but not others (Wyns et al., 2008; Keros et al., 2005, 2007). Somewhat different from reports in other species, and after an extensive study of several strategies for cryopreservation of immature testis tissue, we concluded that glycerol was a better cryoprotectant for pig tissues (Abrishami et al., 2010a). These results suggest that each species and donor developmental age may need a different cryopreservation protocol, with a concomitant need to adjust the concentration of cryoprotectant or even adopt different cryoprotectants. These differences may be related to testicular architecture, morphology, or lipid composition.

In a first report of immature testis tissue vitrification, we also showed maintenance of cell viability and developmental potential to actively (re)establish complete spermatogenesis after xenografting into immunodeficient mice (Abrishami et al., 2010a). Recently, similar or much higher cell viability results were obtained using immature mouse testis tissue with vitrification compared with conventional slow freezing (Gouk et al., 2011; Curaba et al., 2011). With proper tissue handling, and the use of an appropriate choice of final cryoprotectant exposure, vitrification can provide preferential conditions for tissue freezing with proven superior results in restoration of immature testis tissue. Vitrification also does not require the extensive laboratory equipment commonly used for programmed slow freezing; however, direct plunging of tissues into liquid nitrogen, a common procedure in routine vitrification, poses a greater risk of contamination. The solid-surface vitrification of testis tissue (**Fig. 3**) is an easy, safe, and applicable cryopreservation technique for the preservation of tissue structural integrity and developmental potential.

## 6. Conclusion

Although cryopreservation of isolated testis cells has been successfully achieved for animals and humans, only in the past 10 years has intense attention been paid to cryopreservation techniques aimed at maintaining the developmental potential of structurally intact testis tissue. Cryopreservation of testis tissue theoretically offers a practical method when other techniques such as cryopreservation of ejaculated sperm are not available or applicable. Preservation of testis tissue has many applications, including conservation of fertility for prepubertal boys undergoing gonadotoxic cancer therapies. Ovarian and testicular toxicity are the inevitable long-term consequences of certain therapeutic oncological regimens, leading to premature fertility failure or sterility in cancer patients. Cryopreservation of gonadal cells or tissue before high-dose gonadotoxic chemo- and radio-therapy may therefore be considered in a comprehensive treatment and recovery plan. This could provide an alternative method for preserving the fertility potential of prepubertal boys with cancer or azoospermic men, as spermatogenesis is not completed in these patients. Although successful gamete and gonadal tissue restoration could have major impact on the enhancement of fertility preservation, serious ethical implications associated with collection and preservation of human gametes and gonadal tissues have yet to be resolved. Salvaging the genetic potential of immature endangered and valuable animals through banking of gonadal tissue is also a subject of clinical significance in animal reproduction and conservation. Optimal cryoconservation methods could also be combined with transplantation, xenografting, or culturing techniques to overcome some of the complications in the biodiversity crisis of rare or endangered species. In fact, experimental methods for the generation of fertility-competent gametes from cryopreserved ovarian or testis tissues have paved the way for future clinical use in human patients. Therefore,

experimental conservation of gonadal tissue and cells by cryopreservation can serve as a platform for further evaluation of the potential for long-term storage.

Many challenges are associated with the optimal maintenance of tissue structure and the subsequent functional restoration of cryopreserved samples. It is intuitively known that optimal cryopreservation requires refinement of freezing and thawing rates, osmotic conditions, choice and concentration of cryoprotectants, and equilibration times in cryoprotective solutions. Indeed, improvement of all aspects of freezing techniques will ensure survival rates of tissue structure and subsequent functional restoration of cryopreserved cells within those tissues. Several studies have examined cryopreservation of testis cell suspensions or tissue fragments using glycerol, ethylene glycol, DMSO, or propanediol. In most cases, analyses of the cryopreserved samples lacked functional assessments of the preserved testicular cells/tissues. We now know that even if many cells of a multicellular system survive freezing and thawing, preservation of all functional compartments of the tissue is not guaranteed. Merely maintaining the physical characteristics of the cryopreserved testis tissue is not adequate, and an efficient approach to overcome the deficiencies in developmental (re)establishment of spermatogenesis is also required.

## 7. Acknowledgement

The author would like to thank the Natural Sciences and Engineering Research Council (NSERC) of Canada, and the Saskatchewan Health Research Foundation for grants to support the work from the current laboratory summarized here.

## 8. References

- Abbasi S, and Honaramooz A. (2011) Xenografting of testis tissue from bison calf donors into recipient mice as a strategy for salvaging genetic material. *Theriogenology*; 76 607-614.
- Abrishami M, Anzar M, and Honaramooz A. (2010a) Cryopreservation of immature porcine testis tissue to maintain its developmental potential after xenografting into recipient mice. *Theriogenology* 73, 86-89.
- Abrishami M, Abbasi S, and Honaramooz A. (2010b) The effect of donor age on progression of spermatogenesis in canine testicular tissue after xenografting into immunodeficient mice. *Theriogenology* 73, 512-522.
- Abrishami M. (2009) Cryopreservation and xenografting of testis tissue. MSc Thesis. Cryopreservation and xenografting of testis tissue., University of Saskatchewan, Saskatoon.
- adoul P, Donnez J, Dolmans MM, Squifflet J, Lengele B, and Martinez-Madrid B. (2007). Laparoscopic ovariectomy for whole human ovary cryopreservation: technical aspects. *Fertil Steril* 87, 971-975.
- Anchordoguy TJ, Rudolph AS, Carpenter JF, and Crowe JH. (1987) Modes of interaction of cryoprotectants with membrane phospholipids during freezing. *Cryobiology*; 24 324-31.
- Apperley JF, and Reddy N. (1995) Mechanism and management of treatment-related gonadal failure in recipients of high dose chemoradiotherapy. *Blood Rev* 9, 93-116.
- Arregui L, Rathi R, Megee SO, Honaramooz A, Gomendio M, Roldan ER, and Dobrinski I. (2008) Xenografting of sheep testis tissue and isolated cells as a model for preservation of genetic material from endangered ungulates. *Reproduction* 136, 85-93.

- Avarbock MR, Brinster CJ, and Brinster RL. (1996) Reconstitution of spermatogenesis from frozen spermatogonial stem cells. *Nat Med*; 2 693-6.
- Bagchi A, Woods EJ, and Critser JK. (2008) Cryopreservation and vitrification: recent advances in fertility preservation technologies. *Expert Rev Med Devices*; 5 359-70.
- Benson EE. (2004) Principles of Cryobiology. In Lane, NJ, Benson EE, Fuller BJ (eds). *Life in the frozen states*, CRC Press, Boca Raton.
- Brinster RL and Nagano M. (1998) Spermatogonial stem cell transplantation, cryopreservation and culture. *Semin Cell Dev Biol*; 9 401-9.
- Brinster RL, and Avarbock MR. (1994) Germline transmission of donor haplotype following spermatogonial transplantation. *Proc Natl Acad Sci USA* 91, 11303-11307.
- Brinster RL, and Zimmermann JW. (1994) Spermatogenesis following male germ-cell transplantation. *Proc Natl Acad Sci USA* 91, 11298-11302.
- Brook P, Radford J, Shalet S, Joyce A, and Gosden R. (2001). Isolation of germ cells from human testicular tissue for low temperature storage and autotransplantation. *Fertil Steril* 75, 269-274.
- Courbiere B, Odagescu V, Baudot A, Massardier J, Mazoyer C, Salle B, and Lornage J. (2006) Cryopreservation of the ovary by vitrification as an alternative to slow-cooling protocols. *Fertil Steril* 41, 1243-1251.
- Crowe JH, Carpenter JF, Crowe LM, Anchoroguy TJ (1990) Are freezing and dehydration similar stress vectors? A comparison of modes of interaction of stabilizing solutes with biomolecules. *Cryobiology*; 27 219-31.
- Curaba M, Verleysen M, Amorim AC, Dolmans M-M, Van Langendonck A, Hovatta O, Wyns C, and Donnez J. (2011) Cryopreservation of prepubertal mouse testicular tissue by vitrification. *Fertil Steril* 95, 1229-1234.
- Deanesly R. (1954) Immature rat ovaries grafted after freezing and thawing. *J Endocrinol*; 11 197-200.
- Fabbri R, Porcu E, Marsella T, Rocchetta G, Venturoli S, and Flamigni C. (2001) Human oocyte cryopreservation: new perspectives regarding oocyte survival. *Hum Reprod*; 16 411-6.
- Fleck RA, Benson EE, Bremner DH, and Day JG. (2000) Studies of free radical-mediated cryoinjury in the unicellular green alga *Euglena gracilis* using a non-destructive hydroxyl radical assay: a novel approach for developing protistan cryopreservation strategies. *Free Radic Res*; 32 157-70.
- Franca LR, Silva V.A, Jr., Chiarini-Garcia H, Garcia SK, and Debeljuk L. (2000) Cell proliferation and hormonal changes during postnatal development of the testis in the pig. *Biology of Reproduction*; 63 1629-36.
- Frankenhuis MT, Wensing CJG, and Kremer J. (1981) The influence of elevated testicular temperature and scrotal surgery on the number of gonocytes in the newborn pig. *International Journal of Andrology*; 4 105-10.
- Fuller B and Paynter S. (2004) Fundamentals of cryobiology in reproductive medicine. *Reprod Biomed Online*; 9 680-91.
- Fuller BJ. (2004) Cryoprotectants: the essential antifreezes to protect life in the frozen state. *Cryo Letters*; 25 375-88.
- Gañán N, Gomendio M, and Roldan ER (2009). Effect of storage of domestic cat (*Felis catus*) epididymides at 5 degrees C on sperm quality and cryopreservation. *Theriogenology* 72, 1268-1277.
- Gianaroli L, Selman HA, Magli MC, Colpi G, Fortini D, and Ferraretti AP. (1999) Birth of a healthy infant after conception with round spermatids isolated from cryopreserved testicular tissue. *Fertil Steril* 72, 539-541.

- Goossens E, Frederickx V, Geens M, De Block G, and Tournaye H. (2008) Cryosurvival and spermatogenesis after allografting prepubertal mouse tissue: comparison of two cryopreservation protocols. *Fertil Steril*; 89 725-7.
- Gosden RG, Baird DT, Wade JC, and Webb R. (1994) Restoration of fertility to oophorectomized sheep by ovarian autografts stored at -196 degrees C. *Hum Reprod*; 9 597-603.
- Gouk SS, Loh YFJ, Kumar SD, Watson PF, and Kuleshova LL. (2011) Cryopreservation of mouse testicular tissue: Prospect for harvesting spermatogonial stem cells for fertility preservation. *Fertil Steril* 95, 2399-2403.
- Green SH, Smith AU, and Zuckerman S. (1956) The number of oocytes in ovarian autografts after freezing and thawing. *J Endocrinol*; 13 330-4.
- Honaramooz A, and Yang Y. (2011) Recent advances in application of male germ cell transplantation in farm animals *Vet. Med. International*. 2011, 657860.
- Honaramooz A, Behboodi E, Blash S, Megee SO, and Dobrinski I. (2003a) Germ cell transplantation in goats. *Mol. Reprod. Dev.* 66, 21-28.
- Honaramooz A, Behboodi E, Megee SO, Overton SA, Galantino-Homer H, Echelard Y, and Dobrinski I. (2003b) Fertility and germline transmission of donor haplotype following germ cell transplantation in immunocompetent goats *Biol. Reprod.* 1260-1264.
- Honaramooz A, Cui XS, Kim NH, and Dobrinski I. (2008) Porcine embryos produced after intracytoplasmic sperm injection using xenogeneic pig sperm from neonatal testis tissue grafted in mice. *Reprod. Fertil. Dev.* 20, 802-807.
- Honaramooz A, Li MW, Penedo MC, Meyers S, and Dobrinski I. (2004) Accelerated maturation of primate testis by xenografting into mice. *Biol. Reprod.* 70, 1500-1503.
- Honaramooz A, Megee SO, and Dobrinski I. (2002b) Germ cell transplantation in pigs. *Biol. Reprod.* 66, 21-28.
- Honaramooz A, Snedaker A, Boiani M, Scholer H, Dobrinski I, and Schlatt S. (2002a) Sperm from neonatal mammalian testes grafted in mice. *Nature*; 418 778-81.
- Hughes PE, and Varley MA. (1980) *Reproduction in the Pig*. United Kingdom: Butterworth and Co.
- Hunt CJ, Taylor MJ, and Pegg DE. (1982) Freeze-substitution and isothermal freeze-fixation studies to elucidate the pattern of ice formation in smooth muscle at 252 K (-21 degrees C). *J Microsc*; 125 177-86.
- Jadoul P, Donnez J, Dolmans MM, Squifflet J, Lengele B, and Martinez-Madrid B. (2007). Laparoscopic ovariectomy for whole human ovary cryopreservation: technical aspects. *Fertil Steril* 87, 971-975
- Jahnukainen K, Ehmcke J, Hergenrother SD, and Schlatt S. (2007) Effect of cold storage and cryopreservation of immature non-human primate testicular tissue on spermatogonial stem cell potential in xenografts. *Hum Reprod*; 22 1060-67.
- Jezek D, Schulze, W., Kalanj-Bognar, S., Vukelic,Z., Milavec-Puretic, V., Krhen, I. (2001) Effects of various cryopreservation media and freezing-thawing on the morphology of rat testicular biopsies. *Andrologia*; 33 368-78.
- Kasai M and Mukaida T. (2004) Cryopreservation of animal and human embryos by vitrification. *Reprod Biomed Online*; 9 164-70.
- Keros V, Hultenby K, Borgstrom B, Fridstrom M, Jahnukainen K, and Hovatta O. (2007) Methods of cryopreservation of testicular tissue with viable spermatogonia in pre-pubertal boys undergoing gonadotoxic cancer treatment. *Hum Reprod*; 22 1384-95.

- Keros V, Rosenlund B, Hultenby K, Aghajanova L, Levkov L, and Hovatta O. (2005) Optimizing cryopreservation of human testicular tissue: comparison of protocols with glycerol, propanediol and dimethylsulphoxide as cryoprotectants. *Hum Reprod*; 20 1676-87.
- Kishikawa H, Tateno H, and Yanagimachi R. (1999) Fertility of mouse spermatozoa retrieved from cadavers and maintained at 4 degrees C. *J Reprod Fertil* 16, 217-222.
- Leibo SP, Farrant J, Mazur P, Hanna MG, Jr., and Smith LH. (1970) Effects of freezing on marrow stem cell suspensions: interactions of cooling and warming rates in the presence of PVP, sucrose, or glycerol. *Cryobiology*; 6 315-32.
- Lovelock JE and Bishop MW. (1959) Prevention of freezing damage to living cells by dimethyl sulphoxide. *Nature*; 183 1394-5.
- Maksudov GY, Shishova NV, and Katkov II. (2009) In the Cycle of Life: Cryopreservation of Post-Mortem Sperm as a Valuable Source in Restoration of Rare and Endangered Species. In: *Endangered Species: New Research*. Eds.: A.M. Columbus and L. Kuznetsov. NOVA Science Publishers, Hauppauge NY, pp 189-240.
- Martínez AF, Martínez-Pastor F, Alvarez M, Fernandez-Santos MR, Estes MC, de Paz P, Garde JJ, and Anel L. (2008) Sperm parameters on Iberian red deer: electroejaculation and post-mortem collection. *Theriogenology* 15, 216-226.
- Martinez-Madrid B, Camboni A, Dolmans MM, Nottola SA, Van Langendonck A, and Donnez J. (2007). Apoptosis and ultrastructural assessment after cryopreservation of whole human ovaries with their vascular pedicle. *Fertil Steril* 87, 1153-1165.
- Mazur P. (1990) Equilibrium, quasi-equilibrium and non-equilibrium freezing of mammalian embryos. *Cell Biophys*; 17 53-92.
- Mazur P. (2004) Principles of Cryobiology. In Fuller, B, Lane N, Benson EE (eds). *Life in the frozen states*, CRC Press, Boca Raton.
- Mc Laren A and Biggers JD. (1958) Successful development and birth of mice cultivated *in vitro* as early as early embryos. *Nature*; 182 877-8.
- Milazzo JP, Vaudreuil L, Cauliez B, Gruel E, Masse L, Mousset-Simeon N, Mace B, and Rives N. (2008) Comparison of conditions for cryopreservation of testicular tissue from immature mice. *Hum Reprod*; 23 17-28.
- Nagano M, Patrizio P, and Brinster RL (2002). Long-term survival of human spermatogonial stem cells in mouse testes. *Fertil Steril* 78, 1225-1233.
- Nakai M, Kaneko H, Somfai T, Maedomari N, Ozawa M, Noguchi J, Ito J, Kashiwazaki N, and Kikuchi K. (2010) Production of viable piglets for the first time using sperm derived from ectopic testicular xenografts. *Reproduction* 139, 331-335.
- Naysmith TE, Blake DA, Harvey VJ, and Johnson NP. (1998) Do men undergoing sterilizing cancer treatments have a fertile future? *Hum Reprod* 13, 3250-3255.
- Oatley JM, de Avila DM, Reeves JJ, and McLean DJ. (2004) Spermatogenesis and germ cell transgene expression in xenografted bovine testicular tissue. *Biol. Reprod.* 71, 494-501.
- Ogawa T, Dobrinski I, Avarbock MR, and Brinster RL. (1999) Xenogeneic spermatogenesis following transplantation of hamster germ cells to mouse testes. *Biol Reprod*; 60 515-21.
- Parkes AS. (1958) Factors affecting the viability of frozen ovarian tissue. *J Endocrinol*; 17 337-43.
- Parrot DMV. (1960) The fertility of mice with orthotopic ovarian grafts derived from frozen tissue. *J Reprod Fertil*; 1 230-41.
- Pegg DE. (2002) The history and principles of cryopreservation. *Semin Reprod Med*; 20 5-13.

- Pegg DE. (2007) Principles of cryopreservation. *Methods Mol Biol*; 368 39-57.
- Pelliniemi LJ. (1975) Ultrastructure of the early ovary and testis in pig embryos. *American Journal of Anatomy*; 144 89-112.
- Polge C, Lovelock, JE. (1952) Preservation of bull semen at -79C. *The Veterinary Record*; 64 396-97.
- Polge C, Smith AU, and Parkes AS. (1949) Revival of spermatozoa after vitrification and dehydration at low temperatures. *Nature*; 164 666.
- Porcu E, Fabbri R, Seracchioli R, Ciotti PM, Magrini O, and Flamigni C. (1997) Birth of a healthy female after intracytoplasmic sperm injection of cryopreserved human oocytes. *Fertil Steril*; 68 724-6.
- Porcu E. (2001) Oocyte freezing. *Seminars in Reproductive Medicine*; 19 221-30.
- Rathi R, Honaramooz A, Zeng W, Schlatt S, and Dobrinski I. (2005) Germ cell fate and seminiferous tubule development in bovine testis xenografts. *Reproduction* 130, 923-929.
- Rathi R, Honaramooz A, Zeng W, Turner R, and Dobrinski I. (2006) Germ cell development in equine testis tissue xenografted into mice. *Reproduction* 131, 1091-1098.
- Rosenlund B, Westlander G, Wood M, Lundin K, Reismer E, and Hillensjö T. (1998) Sperm retrieval and fertilization in repeated percutaneous epididymal sperm aspiration. *Hum Reprod* 13, 2805-2807.
- Rudolph AS and Crowe JH. (1985) Membrane stabilization during freezing: The role of two natural cryoprotectants, trehalose and proline. *Cryobiology*; 22 367-77.
- Ryu BY, Orwig KE, Kubota H, Avarbock MR, and Brinster RL. (2004) Phenotypic and functional characteristics of spermatogonial stem cells in rats. *Dev Biol*; 274 158-70.
- Sato T, Katagiri K, Gohbara A, Inoue K, Ogonuki N, Ogura A, Kubota Y, Ogawa T. (2011) In vitro production of functional sperm in cultured neonatal mouse testes. *Nature* 471, 504-507.
- Schlatt S, Honaramooz A, Boiani M, Scholer HR, and Dobrinski I. (2003) Progeny from sperm obtained after ectopic grafting of neonatal mouse testes *Biology of Reproduction*, 68: 2331-2335.
- Schlatt S, Kim SS, and Gosden R. (2002) Spermatogenesis and steroidogenesis in mouse, hamster and monkey testicular tissue after cryopreservation and heterotopic grafting to castrated hosts. *Reproduction*; 124 339-46.
- Schlatt S, Rosiepen G, Weinbauer GF, Rolf C, Brook PF, and Nieschlag E. (1999) Germ cell transfer into rat, bovine, monkey and human testes *Human Reproduction* 14, 144-50.
- Schoysman R, Vanderzwalmen P, Bertin G, Nijs M, and Van Damme B. (1999) Oocyte insemination with spermatozoa precursors. *Curr Opin Urol* 9, 541-545.
- Schrader M, Müller M, Sofikitis N, Straub B, and Miller K. (2002) Testicular sperm extraction in azoospermic cancer patients prior to treatment--a new guideline? *Hum Reprod* 17, 1127-1128.
- Scott HM, Mason JL, and Sharpe RM. (2009) Steroidogenesis in the fetal testis and its susceptibility to disruption by exogenous compounds. *Endocrine reviews*; 30 883-925.
- Shinohara T, Inoue K, Ogonuki N, Kanatsu-Shinohara M, Miki H, Nakata K, Kurome M, Nagashima H, Toyokuni S, Kogishi K, *et al.* (2002) Birth of offspring following transplantation of cryopreserved immature testicular pieces and in-vitro microinsemination. *Hum Reprod*; 17 3039-45.

- Smith AU. (1952) Behaviour of fertilized rabbit eggs exposed to glycerol and to low temperatures. *Nature*; 170 374-5.
- Smith AU. (1961) Biological effects of freezing and supercooling. Edward Arnold, London.
- Snedaker AK, Honaramooz A, Dobrinski I. (2004) A game of cat and mouse: xenografting of testis tissue from domestic kittens results in complete cat spermatogenesis in a mouse host. *J Androl* 25, 926-930.
- Steven AC and Aebi U. (2003) The next ice age: cryo-electron tomography of intact cells. *Trends Cell Biol*; 13 107-10.
- Stiller CA, Desandes E, Danon SE, Izarzugaza I, Ratiu A, Vassileva-Valerianova Z, and Steliarova-Foucher E. (2006) Cancer incidence and survival in European adolescents (1978-1997). Report from the Automated Childhood Cancer Information System project. *Eur J Cancer* 42, 2006-2018.
- Sutton RL. (1992) Critical cooling rates for aqueous cryoprotectants in the presence of sugars and polysaccharides. *Cryobiology*; 29 585-98.
- Taylor MJ, Pegg DE. (1983) The effect of ice formation on the function of smooth muscle tissue following storage at -21°C and -60°C. *Cryobiology*; 20 36-40.
- Tesarik J, Bah Ceci M, Ozcan C, Greco E, and Mendoza C. (1999) Restoration of fertility by in vitro spermatogenesis. *Lancet* 353, 555-556.
- Tesarik J, Cruz-Navarro N, Moreno E, Cañete MT, and Mendoza C. (2000) Birth of healthy twins after fertilization with in vitro cultured spermatids from a patient with massive in vivo apoptosis of postmeiotic germ cells. *Fertil Steril* 74, 1044-1046.
- Travers A, Milazzo JP, Perdrix A, Metton C, Bironneau A, Mace B, and Rives N. (2011) Assessment of freezing procedures for rat immature testicular tissue. *Theriogenology* 76, 981-990.
- Van Straaten HWM and Wensing CJG. (1977) Histomorphometric aspects of testicular morphogenesis in the pig. *Biology of Reproduction*; 17 467-72.
- Whittingham DG, Leibo SP, and Mazur P. (1972) Survival of mouse embryos frozen to -196 degrees and -269 degrees C. *Science*; 178 411-4.
- Whittingham DG. (1977) Fertilization in vitro and development to term of unfertilized mouse oocytes previously stored at -196 degrees C. *J Reprod Fertil*; 49 89-94.
- Wilhelm D, Palmer S, and Koopman P. (2007) Sex determination and gonadal development in mammals. *Physiological reviews*; 87 1-28.
- Wilmot I. (1972) The low temperature preservation of mammalian embryos. *J Reprod Fertil*; 31 513-4.
- Wyns C, Curaba M, Martinez-Madrid B, Van Langendonck A, Francois-Xavier W, and Donnez J. (2007) Spermatogonial survival after cryopreservation and short-term orthotopic immature human cryptorchid testicular tissue grafting to immunodeficient mice. *Hum Reprod*; 22 1603-11.
- Wyns C, Van Langendonck A, Wese F-X, Donnez J, and Curaba M. (2008) Long-term spermatogonial survival in cryopreserved and xenografted immature human testicular tissue. *Hum Reprod*; 23 2402-14.
- Yang Y, Steeg J, and Honaramooz A. (2010). The effects of tissue sample size and media on short-term hypothermic preservation of porcine testis tissue. *Cell Tissue Res* 340, 397-406.



## **Part 4**

### **Farm / Pet / Laboratory Animal ART**



# Cryopreservation of Porcine Gametes, Embryos and Genital Tissues: State of the Art

Heriberto Rodriguez-Martinez

*Department of Clinical and Experimental Medicine, Faculty of Health Sciences,  
Linköping University, Linköping  
Sweden*

## 1. Introduction

Preservation of germplasm (e.g. a term hereby applied to collectively gather spermatozoa, oocytes or early embryos whose use would –eventually– lead to offspring) for research, repository building and propagation of genetic material using Assisted Reproductive Techniques (ART) has been a long lasting priority (Mazur et al 2008). The first approaches, besides those historically anecdotic (see Flowers 1999) were directed to the application of artificial insemination (AI) of domestic species (Foote 1999) pertaining dissemination of genetics to a general population of, particularly, production animals. Positive effects for simple cryo-protectant agents (CPA) such as glycerol on animal sperm cryoprotection were demonstrated already by the end of the 1930's (Bernschtein & Petropavloski 1937) and a decade later it became apparent that spermatozoa could be cooled, frozen and thawed in solutions containing egg yolk and glycerol (Polge et al 1949). For some species, such as bovine, the fact that bull semen could be easily frozen with an acceptable sperm survival post-thaw and accompanied by acceptable fertility after intra-uterine AI led to the rapid development of such primary reproductive biotechnology (Rodriguez-Martinez & Barth 2007). Attempts in other species of domesticated animals followed, and it was soon realised that the success seen with bovine could not be reached, primarily due to low sperm survival, difficulties in attaining an optimal deposition or proper timing towards spontaneous ovulation. Differences in survival and fertility varied not only among species but also between individuals of a given species or even ejaculates within sires (Holt 2000).

Porcine male germplasm freezing started already by the 1950's (Polge 1956) but their post-thaw fertility was not reassured using cervical AI until a decade later (Crabo and Einarsson 1971, Graham et al 1971, Pursel & Johnson 1971), which revealed major constrains when applying cryopreservation on boar spermatozoa. Today, despite documented efforts to reach acceptable fertility and prolificacy after AI (Eriksson et al 2002, Roca et al 2011), the cryosurvival of boar spermatozoa is still consistently low in comparison to other species, owing to damage during a processing that is time-consuming, costly and yields few doses per ejaculate (see Rath et al 2009, Rodriguez-Martinez & Wallgren 2011). Number of piglets born is lower than for cooled or neat semen implying that sperm lifespan, deposition site and closeness to ovulation are yet significant hurdles to be overcome (Roca et al 2006b, Wongtawan et al 2006). Preservation of male genetics can also be performed by freezing of

epididymal spermatozoa (retrieved by biopsy of the cauda) or by tissue sampling through testicular biopsies (Keros et al 2005, Curaba et al 2011). However, these approaches are not relevant for porcine breeding. Cauda epididymal spermatozoa are easier to slow freeze than ejaculated spermatozoa (Rath & Niemann 1997) and testicular biopsies are not advisable in boars owing to their highly vascularized testicular capsule (Ohanian et al 1979).

Preservation of female genetics can be done either by freezing of germplasm (e.g. oocytes or embryos) or of ovarian tissue (slices or whole ovary), from which oocytes can thereafter be harvested for ART. Germplasm freezing in pigs has also followed a tortuous road, with deceiving results for decades, particularly related to the high sensitivity of pig oocytes and early embryos to chilling, similarly to other species containing large deposits of intracellular lipids (Zhou & Li 2009), in contrast to blastocysts where the lipid amounts were lower. Delipidation (or side-dislocation of lipid depots by ultracentrifugation) was soon shown to increase the survival of oocytes/embryos subjected to freezing (Nagashima et al 1995), survival that could be enhanced if the cytoskeleton could be preserved from damage using exogenous chemicals (Shi et al 2006). Use of alternative methods such as vitrification instead of slow cooling led to better survival (see Massip 2001) including the birth of offspring (Berthelot et al 2000). However, large variation was seen among methods, sources and laboratories (Holm et al 1999, Cuello et al 2007, Somfai et al 2008, Ogawa et al 2010), including the method used for intrauterine deposition (Rodriguez-Martinez 2007b, Roca et al 2011).

Cryopreservation of ovarian tissue (or even of whole ovaries) has been tested in several species including human (Isachenko et al 2009) pertaining the recovery of follicular oocytes for ART or ultimate autographs (Kim et al 2010). Procedures for porcine ovarian samples have followed methods tested in other species (Imhof et al 2004, Borges et al 2009) with promising results, albeit yet at an academic level, pertaining the advancement of xenografting (Moniruzzaman et al 2009). As well, experimental models using the porcine species have been developed for cryopreservation of genital tissues, particularly the uterus (Dittrich et al 2004, 2006) paving the way for human transplantation procedures (Diaz-Garcia et al 2011).

Thus, interest has been large to attempt routine cryopreservation of porcine gametes, embryos and genital tissues, yet with various degrees of success. Therefore, the present review aims to summarize the state-of-the-art regarding established and emerging methods for the cryopreservation of porcine gametes and embryos as germplasm, intending a critical revision of the underlying problems that still constrain their application for establishing repositories, their use in reproductive biotechnologies and, ultimately, for breeding. As well, it intends to describe our level of knowledge when attempting cryogenics of gonads and other genital tissues for comparative research, particularly on human regenerative medicine. The review is not exhaustive and focus on methodological aspects of procedures.

## **2. What happens during cryopreservation?**

Independently of the cell or tissue above mentioned being considered, the current methods for their cryopreservation fall into one of the two following categories: (i) slow equilibrium freezing or, (ii) rapid non-equilibrium vitrification, and variations within. In either case, the

entire process basically concerns the way we handle the presence of water in and around the cells and whether its freezing is allowed (conventional cryopreservation, slow equilibrium freezing) or totally prevented (vitrification).

In the first method, which is the one traditionally used in biomedicine, particularly for sperm preservation, cells are subjected to slow cooling to temperatures below zero, with freezing rates of 0.5-100 °C/min). The method allows ice to form and solute to concentrate alongside the change in water phase. Both ice and high solute concentrations can cause direct (either initial or eutectic, Han & Bischof 2004a), respectively secondary damage, jeopardizing cell survival or handicapping vital cell functions post-thaw. At some moment during the process, water freezes to form ice, primarily extracellular, but even intracellular. Ice grows and becomes over time surrounded by an increasing amount of solutes which move to the areas where water did not yet changed phase. Cells balance ion concentrations at either side of the plasma membrane thus keeping proper osmotic pressure. Depending on the relative amounts of free and bound water, such a change of phase (either formation or dissolution of ice and de/rehydration phenomena) implies changes in ionic concentration caused by directional movement of water across the membrane, disturbing the homeostatic osmotic pressure of the cell/s (Pegg 2007). Cells respond by allowing water to leave the intra-cellular compartment, to compensate the increasing hyper-osmotic extra-cellular compartment caused by the progressive formation of ice. Those water movements lead both to cell dehydration and to a toxic hyper-concentration of solutes intracellular which, ultimately, affects cells viability (Watson & Fuller 2001). Freezing injury can then be related to high electrolyte concentration effects (solute effects), presence of intracellularly ice (formed direct or eutectic) and also the pressure of large extracellular crystals on the veins of concentrated (i.e. vitrified) extender and cells (Saragusty et al 2009). See **Figures 1 and 2** for an illustration of these events.

Freezing injury during slow freezing can be minimized. Intracellular freezing is generally lethal but can be avoided by sufficiently slowing the rate of cooling. Solute-caused damage, which is the dominating feature under conventional slow freezing especially in cells in liquid suspension, can be minimized by the addition of CPA. Most CPA's (as glycerol, dimethyl sulfoxide (DMSO), ethylenglycol (EG), propyleneglycol (PG)) are highly soluble, permeating compounds of low-to-medium toxicity, whose primary role is to reduce the amount of ice formed at any given sub-zero temperature, by simply increasing the total concentration of all solutes in the system, thus defining the concept of slow equilibrium freezing (Pegg 2002 2007). Introduction of sufficient CPA would eventually avoid freezing and a glassy of vitreous state could be produced instead. Such concept is the theoretical rationale for the second method listed above: rapid non-equilibrium vitrification. Vitrification is the physical process by which a highly concentrated cryoprotective solution supercools to very low temperatures (often to -120 to -130 °C) to finally solidify into a metastable glass, without undergoing crystallization at a practical, high speed cooling rate (i.e. dipping onto LN<sub>2</sub>). Use of ultra-high speed voids the need of penetrating CPA, open for using non-penetrating CPA (such as sucrose, fructose, glucose), but demands the use of small (5-50µL) suspension droplets. The glassy state is defined by its viscosity reaching 10-13 poises, sufficient for the aqueous material to behave as a solid, without any water crystallization. Once again, this waives the above listed sources for cell injury: ice crystals and increased/ill distributed solute

concentrations. The CPA used to vitrify cells include those used during conventional freezing but at very high concentrations (10-fold higher compared to slow freezing), near the maximum tolerated by the cells, thus becoming potentially harmful (Pegg 2005). Penetrating CPA-free vitrification was attempted already by the early 1940's using rabbit spermatozoa plunged into LN<sub>2</sub> (Hoagland & Pincus 1942). Use of non-penetrating "CPA" (CPA-free concept) such as sucrose has proven feasible for the spermatozoa of some species, including human (Isachenko et al 2004, 2005, 2008, Hossain & Osuamkpe 2007), primates (Dong et al 2009), or canine (Sanchez et al 2011), where sperm suspensions were vitrified (either drop-wise, Isachenko et al (2004, 2005) or contained in 50µL-plastic capillaries (Isachenko et al 2011)) by plunging in LN<sub>2</sub>, with a cooling rate of ~10,000 °C/min. Basically, vitrification is therefore always determined by a relation between cooling rate, medium viscosity and sample size.

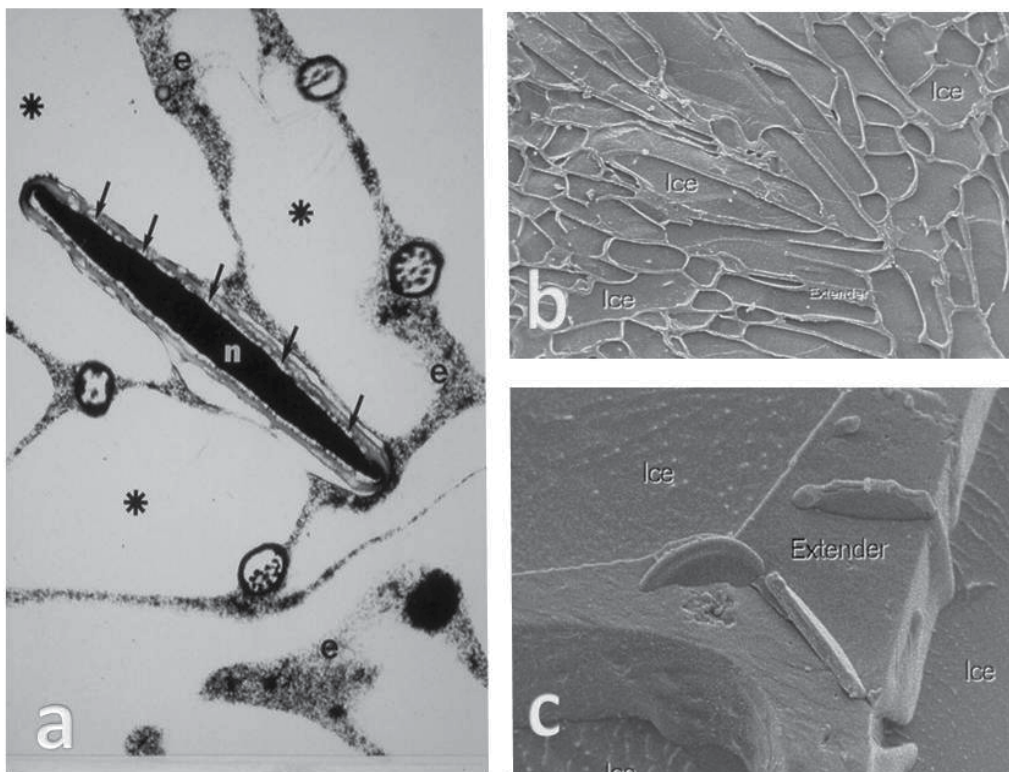

Fig. 1. Micrographs of frozen boar semen illustrated with (a) transmission electron microscopy or (b,c) Cryo-scanning electron microscopy. Spermatozoa were extended and conventionally frozen in maxi-straws (a, 5 mL) or FlatPack™ (b,c, 5 mL) and subjected to freeze-substitution (a) or partial sublimation (b,c) to depict extracellular ice lakes (\* in a, marked with legend in b,c) and the veins of concentrated extender (e in a, legend in b,c). Note the presence of intracellular ice marks (arrows in a) and the dislocation of axoneme structures in the tails. Such marks are not seen in the FlatPack™ material (Photo: Dr Hans Ekwall, Uppsala, Sweden).

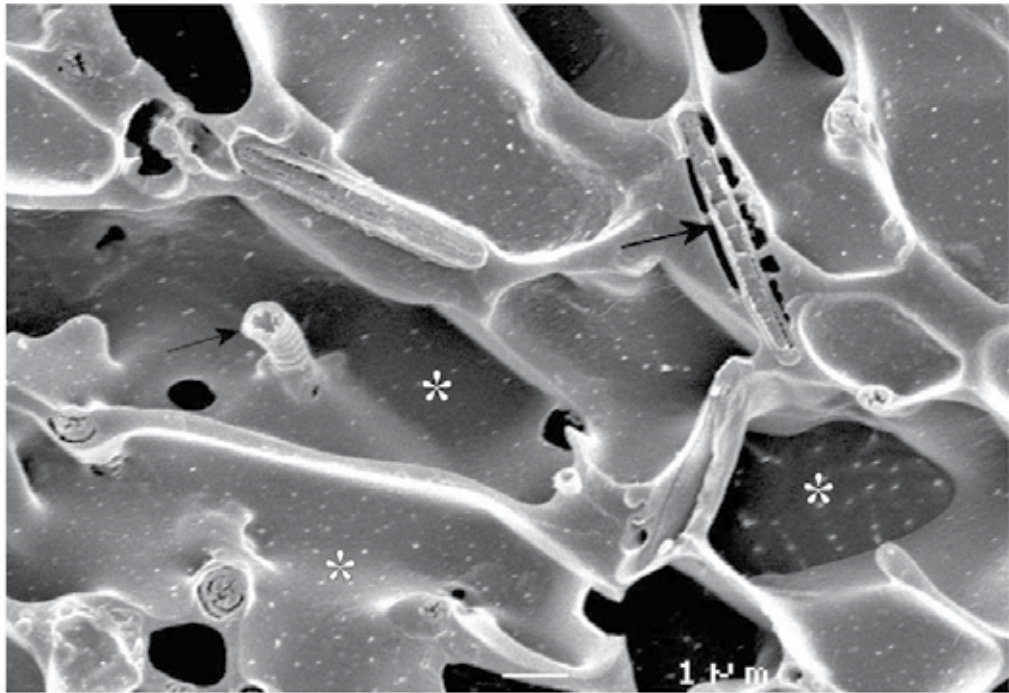

Fig. 2. Cryo-scanning electron microscopy (cryo-SEM) micrograph at higher magnification showing the contents of a maxi-straw frozen at the speed of  $1,200^{\circ}\text{C}/\text{min}$  (by direct plunging into  $\text{LN}_2$  after initial cooling to  $+5^{\circ}\text{C}$ ). The ice lakes (\*) are small, and surrounded by prominent veins. This fast cooling caused freezing of water both extra- and intracellularly, with clear evidence of sub-cellular distortion caused by the presence of intracellular ice crystals in the peri-nuclear and peri-axonemal areas, owing to a lack of sperm dehydration during the process. Note the fractured sperm head (large arrow) with marks of lethal intracellular ice, and the tail entrapped by extracellular ice (small arrow) with dislocation of the axoneme (Courtesy of Dr Hans Ekwall).

However, we should bear in mind that the physical phenomenon of vitrification (e.g. the process by which a liquid begins to behave as a solid during cooling without substantial changes in molecular arrangement or thermodynamic state variables) is as relevant to conventional freezing, where the cells survive in this glassy medium between ice crystals (see **Figure 1a-c**) as to vitrification *per se*, where the entire sample is vitrified (Wowk 2010). Therefore, seeding is quite relevant for supercooled vitrification solutions in conventional freezing, while it does not play any role during pure vitrification, provided that cooling rates are high. For instance, use of  $\text{LN}_2$ -slush (e.g. lowering the temperature to near the freezing point of  $\text{LN}_2$ ,  $-205$  to  $-210^{\circ}\text{C}$  by applying negative pressure to the  $\text{LN}_2$ , Yavin et al 2009) increases the cooling rate 2 to 7-fold compared to simple plunging in  $\text{LN}_2$ . Viscosity also plays a major role and must increase during cooling, until the glass transition (i.e. the change from liquid to solid) is reached. This concept opens for the freezing of highly concentrated semen samples, provided the size of the sample is small enough.

When thawing or re-warming occurs, the events above described basically reverse. Slow re-warming allows water to reflux to the areas where solutes are concentrated in cells treated

by slow freezing, but the time elapsing is not short enough to avoid the toxicity that the solute concentration exerts on the cells, either leading to cell death or dysfunction. If the re-warming is too slow, ice (intracellular in particular) can damage organelles and the cytoskeleton. Rapid rewarming diminishes these risks since the toxic solutes or CPA are only momentarily present.

For either method listed, the CPA has to gain access to all areas of the cell/tissue/organ. Traditional cooling and re-warming rates affect the fluidity of the membranes of the cell and the organelles through the rearrangement of structural proteins and the dislocation of constituent lipids. If these changes affect diffusion and/or osmosis, they can jeopardize -by causing changes in the viscosity of fluids or inducing osmotic imbalance- the proper distribution of the CPA, its introduction and removal and ultimately, the freezing and the thawing process (Morris 2006, Morris et al 2007). Cooling can disrupt the integrity of the cytoskeleton and of the chromatin structure, including DNA damage (Watson & Fuller 2001, Fraser et al 2011). In cells in suspension, such as spermatozoa, both the form and volume of the sample to be cooled/re-warmed, and the concentration of the contained cells play major roles during the most damaging interval in the process, i.e. during the changes in phase of the extra-cellular water, when heat is either dissipated (during cooling) or incorporated (during re-warming) (Mazur & Cole 1989, Morris et al 1999). It is therefore obvious that samples (cells, tissues, organs) have to pass cooling and re-warming under conditions where cell injury can be minimized (Morris 2006, Morris et al 2007).

### **3. Cryopreservation of boar semen: State-of-the-art**

Porcine AI with liquid-stored semen where either the entire ejaculate or only the sperm-rich fraction (SRF) of the ejaculate is collected, the spermatozoa are re-suspended at low concentrations in chemically defined extenders and stored at 16–20°C for several days before use, most often for up to 3 days) has increased exponentially in the past 25 years. Globally, AI is practiced in 75% of sows (range 10-99%) using >160 million semen doses, with countries in Europe and the Americas having basically all sows under AI (Riesenbeck 2011). Fertility rates are similar to those obtained after natural mating (for a review, see Rodriguez-Martinez 2007a). Liquid semen is therefore used both for production breeding and for genetic improvement at national or regional level, with some export countries having a major international trade. However, the limited shelf-life of liquid semen, its decline in fertility over transit time, and risks of damage due to temperature, pressure or handling changes, all call for alternatives, with a focus on frozen-thawed semen.

Boar spermatozoa are still being “best” cryopreserved (in terms of cryosurvival) using protocols originally devised in the mid 1970’s (Westendorf et al 1975) with modifications (most often empirically introduced). Most methods use standard lactose-egg yolk (or LDL)-based cooling and freezing media, following the removal of most of the seminal plasma by extension in chelate-containing (often EDTA) buffers and centrifugation. The freezing media most often include a surfactant (often laurylsulphate, Orvus es Paste-OEP) and glycerol as CPA (2-3% final concentration added at +5°C). Spermatozoa are further cooled beyond the eutectic temperature at 30 to 50°C/min. Thawing is done at 1,000-1,800 °C/min. The entire procedure takes most often 8-9 hours from semen collection to storage of the frozen doses in LN<sub>2</sub>, being still tedious (many different steps) and, inconvenient, producing few AI-doses



per ejaculate (5-8). For examples of current protocols see Eriksson & Rodriguez-Martinez (2000), Saravia et al (2005), Parrilla et al (2009) or Rath et al (2009) and methods cited therein.

This general current protocol fits most boars but considering the large variation between ejaculates and -particularly- among boars for their capacity to sustain cryopreservation (Roca et al 2006a), the protocol has to be modified to accommodate those with sub-optimal sperm freezability (the so-called bad freezers), particularly regarding glycerol concentration and warming rates (Hernandez et al 2007a). Those changes usually allow for minimum acceptable cryosurvival (i.e. around 40%). However, it clearly shows that the methodology is still sub-optimal. Current semen cryopreservation techniques are technically demanding and expensive, both in terms of labour- and laboratory equipment costs, as well as time-consuming (rev by Roca et al 2006b, 2011). Last but not least, there is a lack of reliable laboratory tests for the accurate assessment of semen quality *in vitro*, that limits our capacity to properly monitor the methods used to freeze-thaw boar semen and, particularly, its relationship to AI-fertility (Rodriguez-Martinez, 2007b). This is critical, since despite having acceptable post-thaw survival (even above 60%) this cryosurvival is not reflected in fertility after AI. Thus, boar spermatozoa are considered one of the most demanding cell types with respect to sustaining viability during freezing and thawing, with a large proportion of the spermatozoa not surviving these procedures (Penfold & Watson 2001). Moreover, those surviving spermatozoa are usually a mixture of cells, some of which survive well while others show modified motility and a shortened lifespan, factors which compromise their fertilising ability. Insemination with such spermatozoa leads, ultimately, to lowered pregnancy rates and fewer piglets born, compared with AI using liquid-stored semen (Knox 2011). In sum, although freezing methods are nowadays rather stable in many laboratories and yield above 50% of sperm survival post-thaw, fertility after AI is extremely variable (Parrilla et al 2009). The major constrain is not only the inherent difficulties to freeze spermatozoa from this species (Holt, 2000a,b), but -within the species- the sire-dependent cryosurvivability to the current procedures (Eriksson et al 2002, Holt et al 2005, Gil et al 2005, Waterhouse et al 2006, Hernandez et al 2006, 2007a, Roca et al., 2006a, Parrilla et al 2009, Roca et al 2011).

This variation is usually compensated by the AI of excessive sperm numbers (at least  $5 \times 10^9$  spermatozoa per AI-dose), i.e. double the numbers of total spermatozoa present in liquid semen doses. Fertility post-AI is nowadays substantially better, closer to AI with liquid semen (Eriksson et al 2002). See **Table 1** for an overview of fertility after conventional (cervical) AI with frozen-thawed boar semen. Fertility with lower sperm numbers is also becoming acceptable when deep intrauterine AI is practiced, although data are still restricted in numbers (Bathgate et al 2006, Roca et al 2006b, 2011). But, even with these huge sperm numbers, overall fertility (as farrowing rates) and prolificacy (as litter size) are still lower than for liquid semen (around 10-30 % lower farrowing rates, and 1-3 less piglets), indicating that other factors are limiting, such as the timing of insemination respective to spontaneous ovulation (Bolarín et al 2006, Wongtawan et al 2006). This implies that we are far from reaching the goals set up by the industry for the use of frozen-thawed semen: 85% of conception rates and a litter size of 11 piglets (Knox 2011). So, frozen-thawed boar semen is still basically limited to research, genetic banking or the export of semen for selected nuclei lines, constituting barely above 1% of all AIs.

Package	AIs	AI-dose (x10 <sup>9</sup> )	Sows	Farrowed (%)	Litter size (n)	References
Pellet	2	6	334	40	6.4	Didion & Schoenbeck 1996
MS	2-4	2.5	392	48	10.4	Almlid & Hofmo 1996
MS	2-4	2.5	496	57	12.2	Almlid & Hofmo 1996
MS	2-4	2.5	350	50	9	Almlid & Hofmo 1996
MS	2	5	190	62.6	9	Hofmo & Grevle 2000
FlatPack™	2	5	352	72.2	10.7	Eriksson et al 2002

Table 1. Fertility after conventional (cervical) AI in field trials (>100 sows) with frozen-thawed boar semen (modified from Roca et al 2006).

Therefore, it seems -at first sight- unlikely that deep frozen semen will replace the use of fresh semen on an extensive basis even if the fertility levels were similar. It is too expensive considering that the current cryopreservation protocols barely yield half of the doses produceable per ejaculate. Since the amount of spermatozoa per dose is minimum twice that of liquid-stored semen, such equation is simply undependable from a commercial point of view both in production costs for AI-doses and the sub-optimal boar use. However, having a reliable cryopreservation method for boar semen would (a) allow selection of genetics from all over the world, (b) enable planned, essential AIs' at the top of the breeding pyramid and so (c) facilitate preservation of top quality genetic lines for ongoing or future breeding programmes and/or (d) offer an extra health safeguard, by allowing completion of any health test specified by a country or breeding organization before use. The challenge is there, undoubtedly.

### 3.1 Improvements in boar semen freezing

Over the past decade, the cryobiology of boar semen has diminished its empiric approach towards a more experimental one. Major areas of research have involved: (i) the determination of *in vivo* features (particularly regarding seminal plasma (SP) and the presence of characteristic fractions of the ejaculate), (ii) the action of specific additives and different CPA, (iii) the use of automated freezers and of directional gradient freezing and, (iv) the use of novel containers adapted for the freezing of concentrated spermatozoa. Fertility post-AI is nowadays substantially better, closer to AI with liquid semen, even when using lower sperm numbers and alternative sites of sperm deposition, such as deeply intra-uterus (Roca et al 2011).

**Specific additives and different CPA's:** Glycerol, a small, poly-hydroxylated solute highly soluble in water since it interacts with it by hydrogen bonding, and able to permeate across the

plasma membrane, at a low rate, is by far the mostly used CPA for boar semen conventional freezing. Since glycerol disturbs cell metabolism at body temperature, boar spermatozoa are usually exposed to this CPA at  $\sim 5^{\circ}\text{C}$ , which –unfortunately– further slows its low rate permeation. Mixed with the other solutes of the extender in solution, it depresses their freezing point and ameliorates the rise in sodium chloride concentration during dehydration. Moreover, glycerol increases viscosity with lowering temperatures to more than 100,000 cP by  $-55^{\circ}\text{C}$  (Morris et al 2006), leading to a retardation of both ice crystal growth and of dehydration speed on a kinetic basis. Moreover, glycerol eliminates eutectic phase changes of the extender (Han & Bischof 2004b), making it a very suitable CPA when added at 2-3% rates. While such interval does not affect cryosurvival in “good-freezer” boars, those considered moderate or bad freezers benefit from a minimum of 3% glycerol (Hernandez et al 2007a). A broad range of other solutes (mostly alcohols, sugars, diols and amides) have also been tested for CPA capacity (Fuller 2004, Buranaamnuay et al 2011), but boar spermatozoa react variably. Alcohols and diols can induce membrane blebbing. Sugars (such as the disaccharides sucrose, raffinose or trehalose which both increase viscosity and stabilise the membrane by interacting with phospholipids) are not better than glycerol, regarding cryosurvival (Hu et al 2008), but shows synergistic effects (Gutierrez-Perez et al 2009, Hu et al 2009). On the other hand, replacing glycerol with amides (formamide; methyl- or dimethylformamide, MF- DMF; acetamide; methyl- or dimethylacetamide (MA- DMA) at  $\sim 5\%$  concentration, has proven beneficial for cryo-susceptible boars, probably because the amide permeates the plasma membrane more effectively than glycerol, thus causing less osmotic damage during thawing (Bianchi et al 2008). Other additives enhance cryosurvival of boar spermatozoa, such as L-glutamine (de Mercado et al 2009) or low rates ( $<0.1\%$ ) of N-acetyl-D-glucosamine (Yi et al 2002a), the latter possibly interacting with the surfactant OEP (Yi et al 2002b). Laurylsulphate, albeit its mode of action is yet unexplained in detail regarding interaction with egg yolk and the sperm plasma membrane, has repeatedly proven valuable (Karosas & Rodriguez-Martinez 1993, Buranaamnuay et al 2009). Use of low-density lipoproteins (LDLs), isolated from egg-yolk from different species (Jiang et al 2007), has proven beneficial for sperm function post-thaw, particularly for DNA-integrity. Similarly, sperm cryosurvival has been enhanced by the addition of antioxidants (Peña et al 2003, 2004a, Roca et al 2005, Jeong et al 2009, Kaeoket et al 2010), hyaluronan (Peña et al 2004b), or platelet-activating factor (PAF, Bathgate et al 2007), although the beneficial effects vary, particularly when different sperm sub-populations are used. Cryosurvival of several cold-shock susceptible species, of which the porcine is one, has been found to improve when cholesterol-loaded cyclodextrins (CLC) are used as additives before cooling (Zeng & Terada 2001, Mocé et al 2010). Cyclodextrins can encapsulate hydrophobic compounds, such as cholesterol, and transfer the cholesterol into membranes down a concentration gradient (Zidovetzki & Levitan 2007). However, it is yet to determine if the effects are substantial and not only individually-related (Waterhouse et al 2006).

**Automated freezers and directional gradient freezing:** Controlled freezing using programmed freezers improves cryosurvival by use of “optimal” cooling (and thawing) rates e.g. those that substantially diminish the period during which heat is released/absorbed in the sample when water changed phase (i.e. ice was formed/melt). Interestingly enough, experimentally-determined optimal rates of the range  $30\text{-}50^{\circ}\text{C}/\text{min}$  (Thurston et al 2003, Medrano et al 2009, Juarez et al 2011) have been theoretically predicted (Devireddy et al 2004, Woelders & Chaveiro 2004) and confirmed by use of novel procedures such as directional freezing where the thermal gradient is monitored by modifying the velocity at which the liquid-ice interface grows so that the size and shape of the ice crystals is maintained within optimal limits. In this methodology,

derived from the principle of seeding, the biological material is moved through a linear temperature gradient, so that both the freezing rate and the ice front propagation are controlled (Arav et al 2002, Woelders et al 2005, Saragusty et al 2007). The method can be advantageously applied both to large samples, frozen in large containers moving along a rim of seeding or to highly concentrated samples, in smaller (i.e. mini-straws) containers.

**Cryobiologically best-suited packaging containers:** use of cryobiologically adequate packaging systems for the extended spermatozoa, showed a direct improvement of cryosurvival. Boar spermatozoa has been processed in plastic straws of different volumes (0.25 to 5 mL, Johnson et al 2000), in flattened 5 mL straws (Weitze et al 1987), in metal (Fraser & Strzezek 2007) or in plastic bags of various types and constitution (Bwanga et al 1991, Mwanza & Rodriguez-Martinez 1993, Ortman & Rodriguez-Martinez 1994; Eriksson & Rodriguez-Martinez 2000, Eriksson & Rodriguez-Martinez 2000, Saravia et al 2005). The latter developed, denominated "FlatPacks™" proven equally good or better than 0.25 mL straws in terms of sperm cryosurvival despite of the fact that they held 5 mL of semen (an entire dose for cervical AI, 5 billion spermatozoa), thus waiving the need of pooling innumerable straws when thawing. Fertility after conventional cervical AI of FlatPack™ frozen-thawed semen yield acceptable farrowing rates and litter sizes (Eriksson et al 2002). See **Figure 3** for a schematic description of the differences between containers. The FlatPack™ was considered as cryobiologically convenient (very thin and with a large surface) to dissipate heat during cooling and warm rapidly, as those small containers tested. It is important to remember that the freezing in these containers, with high heat dissipation, inflicts less damage to the cells by intra-container mechanical pressure (Saragusty et al 2009). **Figure 4** shows cryological differences in shape and size of frozen water lakes between mini-straws and FlatPack™.

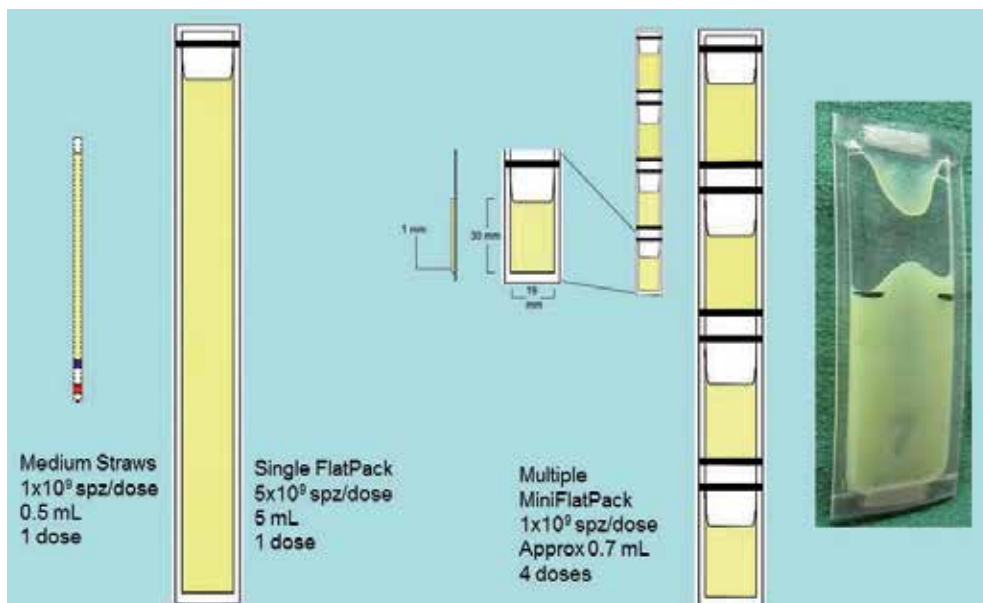

Fig. 3. Schematic representation of the major differences between plastic 0.25 mL mini-straws, with single and Multiple FlatPack™ (the latter also named "MiniFlatPack™", see adjacent photograph of a filled and sealed MiniFlatPack™)(Diagramme/photograph: courtesy of Dr Fernando Saravia).

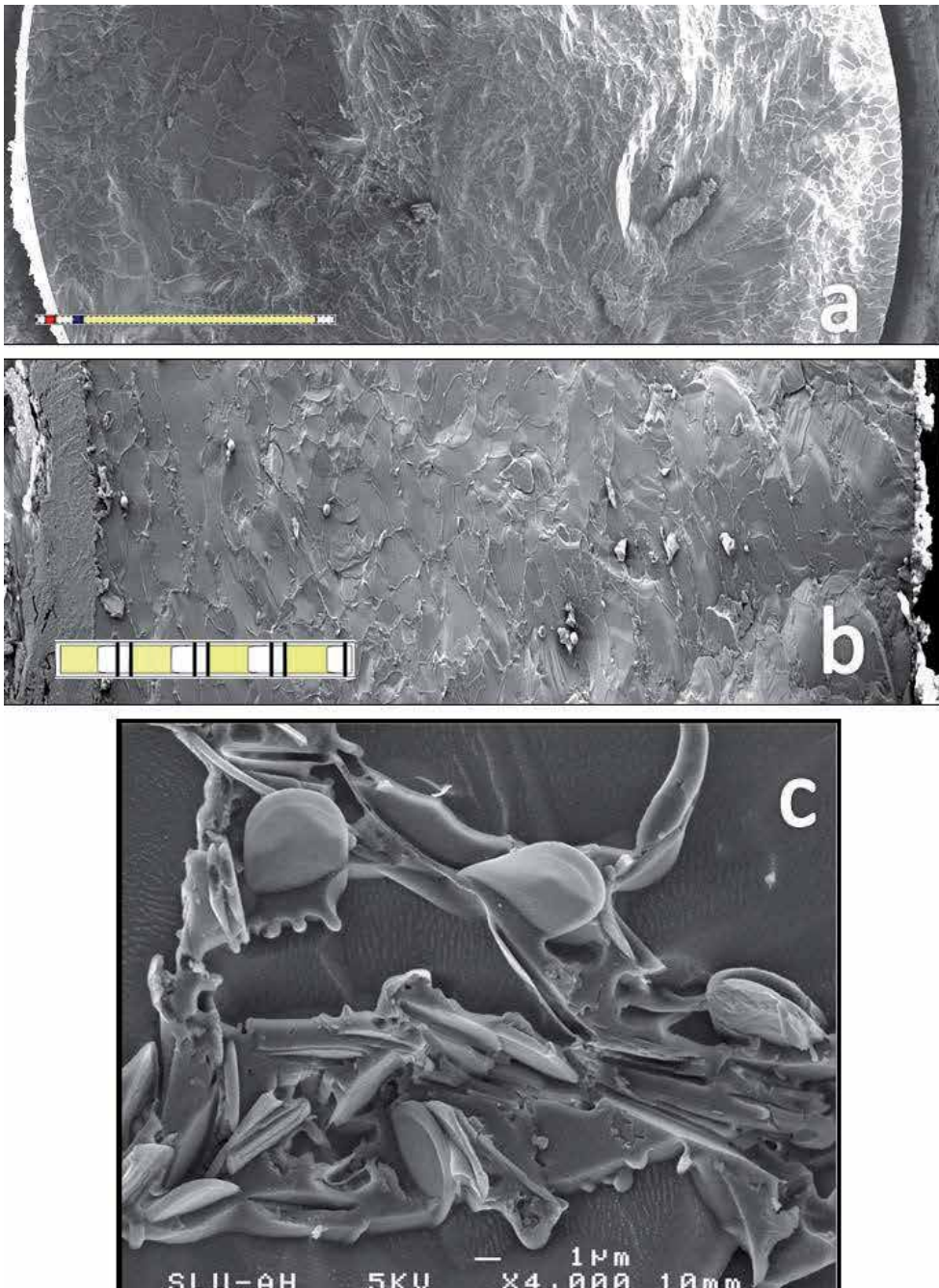

Fig. 4. Cryo-SEM micrographs at low magnification of cross sectioned frozen mini-straw (a) and a MiniFlatPack™ (b) depicting major differences in the orientation and size frozen water lakes/extender veins. In (c) a higher magnification of (b) showing morphologically well preserved boar spermatozoa from the sperm-peak portion of the ejaculate (Courtesy of Dr Hans Ekwall).

However, doses with such large sperm numbers conspire against the best use of the ejaculates and, with the introduction of intrauterine deposition of semen, it opened for the use of smaller containers with high numbers of spermatozoa to contain a single AI-dose. Recently, boar spermatozoa have been frozen, highly concentrated, in small volumes (0.5-0.7 mL) in novel containers, the so-called "MiniFlatPack™" (Saravia et al 2005, 2010, Pimenta-Siqueira et al 2011), as 1-2 billion spermatozoa/mL. Interestingly, cryosurvival (see **Table 2**) was equal or higher than for 0.5 mL plastic straws, suggesting the shape maintained the cryobiological advantages of the FlatPack™ (Ekwall et al 2007), including fertility when using deep-intrauterine AI (Wongtawan et al 2006).

**Sperm vitrification:** Boar spermatozoa packed in 0.12 mm thick film plastic bags were frozen ultra-rapidly at various stages of conventional freezing-thawing and besides survival, samples were explored ultrastructurally, for presence of ice damage. Survival was minimal and ice presence was detected, indicating that cooling rates, although high, were not enough to handle the volumes assayed (Bwanga et al 1991b). Non-penetrating sugars have either been used for vitrification (Meng et al 2010) and also for empirical improvement of slow freezing (Malo et al 2010). There is, *a priori*, nothing against the use of vitrification for freezing small suspensions of boar spermatozoa (for instance for intracytoplasmic sperm injection, ICSI, Meng et al 2010) but there is no practical use for breeding, since the amounts needed are too large to achieve ultra-rapid cooling and thawing rates.

Simplified freezing (SF, 3.5h)		Conventional freezing (CF, 8-9h)	
P1- sperm	SRF-sperm	P1-sperm	SRF-sperm
62.9 ± 3.13	54.2 ± 3.50	70.0 ± 4.40	64.0 ± 2.60

Table 2. Cryosurvival (Computer Assisted Sperm Analysis, CASA, mean±SEM), as percentages of motile spermatozoa, 30 min post-thaw at 38 °C) of ejaculated boar spermatozoa from the sperm-peak portion (P1, first 10mL of the sperm-rich fraction, SRF) or the entire SRF subjected to a simplified (SF, 3.5h) or a conventional freezing (CF, 8h) and an equal thawing (35°C for 20 seconds) (Modified from Saravia et al 2010).

**Learning from the ejaculate:** Boar SP is a composite, heterogeneous fluid composed by fractionated secretions of the epididymal caudae and the accessory sexual glands. *In vivo*, spermatozoa contact some of these fractions but not necessarily all, and different effects (sometimes deleterious, sometimes advantageous) have been recorded *in vitro* when removing (Fraser et al 2007) alternatively keeping boar spermatozoa in its own SP, depending on the fraction used (Guthrie & Welch 2005, Rodriguez-Martinez et al 2009, 2011). The SP or the sperm-rich fraction (SRF) might not be necessary for cryosurvival or fertility, since spermatozoa from boars that were semino-vesiculectomised were able to sustain freezing and thawing equally well as spermatozoa bathing in seminal vesicular proteins (Moore et al 1977). However, we have recently determined that boar spermatozoa

contained in the first 10 mL of the SRF (also called sperm-peak portion or P1, where about ¼ of all spermatozoa in the SRF are) were more resilient to handling (from extension to cooling) and cryopreservation than the spermatozoa contained in the rest of the ejaculate (Peña et al 2003, Rodriguez-Martinez et al 2009, Saravia et al 2007, 2010, Rodriguez-Martinez et al 2008). It appeared that it was actually the SP in this sperm-peak P1 portion that was beneficial for spermatozoa, either because of its higher contents of cauda epididymal fluid and specific proteins, or its lower amounts of seminal plasma spermadhesins, bicarbonate or zinc levels (Rodriguez-Martinez et al 2011), compared to other fractions of the ejaculate (Saravia et al 2010).

In an attempt to simplify the freezing protocol, only the P1-spermatozoa were frozen in concentrated form for eventual use with deep-intrauterine AI. These spermatozoa were firstly kept in their SP for 30 min, and thereafter, without centrifugation (i.e. without removal of the SP) they were mixed with lactose-egg yolk (LEY) extender and cooled down to +5°C within 1.5 h, before being mixed with LEY+glycerol (3%) and OEP and packed into MiniFlatPack™s for customary freezing using 50°C/min cooling rate. This “simplified” entire procedure (SF), lasted 3.5 h compared to the “conventional freezing” (CF) that was used as control procedure, which lasted 8 h. As controls, spermatozoa from the SRF were compared to P1-spermatozoa. Cryosurvival was, as seen in **Table 2**, equally good (above 60% of the processed cells (Saravia et al 2010, Pimenta-Siqueira et al 2011). Moreover, the spermatozoa in the sperm-peak-fraction of the boar ejaculate showed a maintained plasmalemmal intactness and fluidity and a lower flow of Ca<sup>2+</sup> under capacitation conditions post-thaw, which might account for their higher membrane stability after cryopreservation (Hossain et al 2011).

There are several advantages of using this simplified, shorter protocol, namely the exclusion of the customary primary extension and the following removal of this conspicuously beneficial SP-aliquot by centrifugation. As well, it waives the need of expensive refrigerated centrifuges. Moreover, inter-boar variation was minimised by use of P1-spermatozoa which, not only were the “best” spermatozoa to be cryopreserved, but uses a portion of the sperm-rich fraction where the documented “fertility-associated” proteins are present (Rodriguez-Martinez et al 2011). Finally, the procedure frees the rest of the collected spermatozoa (75% of the total sperm count) for additional processing of liquid semen AI-doses. This simpler protocol ought thus to be an interesting alternative for AI-studs to –using the one and the same ejaculate- freeze boar semen (P1) for gene banking or for repopulation or commercial distribution, along with production of conventional semen doses for AI with liquid semen, using the rest of the ejaculate. Such procedures would not disturb routine handling of boars or their ejaculates. Inseminations in the field (deep intra-utero) have shown acceptable figures for farrowing and litter size (Wallgren, personal communication).

#### **4. Cryopreservation of oocytes and embryos**

The slow freezing technique developed for oocytes and embryos in the 1970's (Willadsen et al 1978) has been thoroughly established by the increasing repertoire of CPA where they were gradually exposed to. Cultured cells/embryos are exposed to relatively low concentration of permeating CPA's (glycerol, DMSO, EG or PG at 1-1.5 M (oocytes) or 1.3-1.5 M (embryos) alternatively non-permeating CPA in the culture medium, loaded into mini-straws and cooled at -5 to -7°C, equilibrated for some minutes followed by seeding of extracellular ice nucleation, to be thereafter slowly cooled at ~0.3-0.5°C/minute to -40/-65°C and final plunge in LN<sub>2</sub> for

storage of the now carefully dehydrated and vitrified germplasm (for a comprehensive review see Saragusty & Arav 2011). However, pig oocytes, zygotes and cleavage embryos are rich in cytoplasmic lipids, and very sensitive to temperatures below 15°C (Wilmot 1972), a sensitivity that decreases -along with the amount of lipids- with development, towards peri-hatching blastocysts (Niimura and Ishida 1980). Offspring has been obtained after embryo transfer (ET) of slow-frozen and thawed 2-4 cell pig embryos where these cytoplasmic lipids were removed *in vitro* (de-lipation) before cooling (Hayashi et al 1989, Nagashima et al 1994, 1995, 1996) and thereafter the technique, albeit cumbersome, has been thoroughly applied (Yoneda et al 2004). The results enhanced when the cytoskeleton was preserved from damage using exogenous chemicals (Shi et al 2006).

Over the past years, vitrification (Rall and Fahy 1985) appeared as a better alternative for long-term storage of pig oocytes and embryos. On one hand, the small size of the material to process provided another dimension: vitrification could be modulated via size of sample (10 µL in most cases) so that neither cooling rate nor CPA-amounts ruled so that the method was more practical and less risky. Samples could be handled and carried/stored through either “surface” methods (e.g on liquid loops, mesh of different materials etc) or “tubing” carriers (thin straws, cyropipettes, ultrathin tubing etc). Both yield high cooling rates but while the surface type has the highest warming rates, the other is much easier to handle and, safer (Saragusty & Arav 2011).

On the other hand, vitrification of oocytes and embryos differ in degree of difficulty. As already mentioned, oocytes are more sensitive than embryos, particularly morulas or blastocysts since oocytes have a high cytoplasmic lipid contents (chilling sensitive). Moreover, oocytes have easily disrupted submembranous actin microtubules (which decreases plasmalemma robustness) and fragile meiotic spindle and cytoskeleton, which complicates the resumption of development. Lastly, the process of freezing and thawing can increase the risk for ROS-attack and the premature emptying of cortical granules, thus changing the structure of the zona pellucida (ZP) (Gajda 2009). Therefore, chemical stabilization of the cytoskeleton (Esaki et al 2004) and the use of increased pressure following vitrification (Du et al 2008) had been successfully applied, obtaining development post-rewarming towards the fetal stage (Ogawa et al 2010). Other measures, such as induction of osmotic stress (by exposure to NaCl) has shown to improve developmental competence after vitrification (Lin et al 2008). Centrifugation (lipid depot relocation) for vitrification appears detrimental for *in vitro*-matured oocytes, but not in zygotes or later stages (Somfai et al 2008)

Vitrification of *in vivo*-developed, ZP-intact pig embryos, where lipids were polarized by centrifugation of the blastomeres, by delipation and/or treatment with cytochalasin for cytoskeleton stabilization, has resulted after rewarming and ET, in piglets (Dobrinsky 1997, Dobrinsky et al 2000, 2001, Kobayashi et al 1998, Berthelot et al 2000, 2003, Cameron et al 2000). Blastocysts were also developed by *in vitro* fertilization (IVF) of follicular oocytes vitrified as cumulus-oocyte complexes from offal porcine follicles (Somfai et al 2010).

Recently, piglets were even obtained following vitrification of delipated 4-8 cell stages of *in vitro* produced (IVP), parthenogenetic embryos and ET (Nagashima et al 2007). Vitrification, usually done within 0.25 mL plastics-straws, yield better embryo survival post-warming when Open Pulled Straws (OPS; Vajta et al 1997), which increases the cooling rate achievable in 0.25 mL straws (2,500°C/min) by almost 8-fold (Cuello et al 2004a-b), were used, again resulting in piglets born (Berthelot et al 2000; 2001). Higher cooling-rates



(>20,000°C/min) can nowadays be reached using using cryo-loops (Lane et al 1999) or with straws with a smaller inner diameter and wall thickness (the Superfine Open Pulled Straws: SOPS; Isachenko et al 2003), and by applying immersion in LN<sub>2</sub>-slush, which allowed for the use of lower concentrations of toxic cryoprotectant.

Vitrification of untreated morulae and blastocysts has resulted in high survival rates after warming (Berthelot et al 2003), especially when re-warming after SOPS is done in one stage (direct warming, a very practical solution for ET, Cuello et al 2004b), yielding live litters (Cuello et al 2005). For blastocysts (See **Figure 5**), use of the SOPS waived the need for centrifugation (dislocation of lipids) or microtubule stabilization, thus making the method a very practical one and indicating the procedure is now reaching maturity for commercial application (Cameron et al 2004, Beebe et al 2005, Martinat-Botté et al 2006, Cuello et al 2008, 2010, Sanchez-Osorio et al 2009, 2010). Cryopreservation of in IVP-pig embryos -owing to differences in the cytoskeleton and the distribution of the lipid deposits- has been, until recently (Esaki et al 2004), considered as more difficult than for *in vivo*-developed, but the birth of piglets resulting from ET of IVP, transgenic pig embryos, has modified this view opening for the commercialization of highly valuable, modified genetic material (Li et al 2006, Kawagami et al 2008). Despite peri-hatching blastocyst stage embryos are the ones best sustaining vitrification and warming with continued *in vitro* development (Dobrinsky 2001), this particular embryo stage can not be commercially used since there is no ZP.

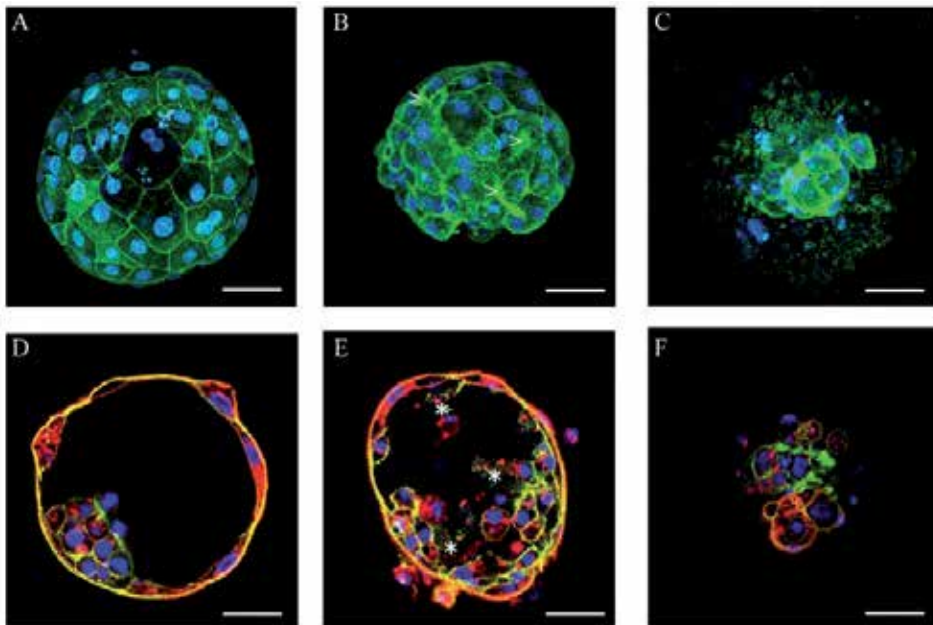

Fig. 5. Laser scanning confocal microphotographs of grade I (A and D), grade II (B and E) or grade III (C and F) in vivo-derived fresh (A-C) and superfine open pulled straws (SOPS)-vitrified (D-F) porcine blastocysts, following uploading of Hoescht H-33342 (blue, cell nuclei), phalloidin-Alexa Fluor 488 (green, actin filaments) and wheat germ agglutinin-Alexa fluor 594 (red, lectin reactive membrane elements). Note the high degree of morphological intactness even after rewarming compared to fresh controls (Reprinted from Cuello et al 2010, with permission).

## 5. Cryopreservation of genital tissues

Freezing of ovarian tissue in humans relate primarily, but not only, to a dramatic measure to warrant availability of oocytes in cases of oncotherapy, when sterility is foreseen, similar to the ongoing sperm banking prior to onco- or hormonal therapy. Rescue of oocytes from frozen samples of ovarian cortex is then feasible for ART (Shaw & Trounson 2002). Both slow freezing and directional freezing had been assayed with acceptable results (Arav & Natan 2009), opening possibilities for the cryopreservation of large samples and even of whole ovary for autografting purposes and possibly evolving in oocyte banking as an insurance against childlessness. Adult testicular samples (aspiration or biopsy) are mainly issued during biopsy for recovery of spermatids for ICSI (Keros et al 2005, Curaba et al 2011). However, the strongly ongoing research in adult stem cells shall be based on the absolute need of properly cryopreserving pre-pubertal testicular tissues. Transplantation of other organs or tissues (uterine in particular) is also within the scope of not-far, albeit discussable, scenarios (Bredkjaer & Grudzinskas 2001).

Regarding the porcine species, although there is no obvious rationale for most of the above considerations in human, it provides an excellent animal model for experimental reproductive medicine, particularly considering transplantation surgery. Porcine whole uteri were arterially perfused with CPA (DMSO) prior to slow controlled freezing. Rewarmed tissues were able to present live cells 7 h post rewarming (Dittrich et al 2006) and even to demonstrate contractility *in vitro* 60 min post-rewarming (Dittrich et al 2010). As such, comparative analyses of equilibrium freezing and vitrification procedures have involved pig ovarian fragments (Gandolfi et al 2006, Borges et al 2009), or whole ovaries (Imhof et al 2004). These attempts were all done using slow freezing, but evidence is now provided that vitrification of thin slices of ovarian cortex is feasible and that rewarmed primordial follicles from these samples were able to develop (albeit slower than controls) in murine xenografts (Moniruzzaman et al 2009). Further development in this area is expected.

## 6. Conclusions

Vitrification as a method for cryopreservation in porcine applies thus far to small samples that can be managed at high cooling and rewarming rates without need of applying permeating CPA of potential toxicity. Therefore, the technique has developmental potential for oocytes, COCs and embryos for IVF and ET. Boar spermatozoa are yet to follow this path, and although there is a potential breach for vitrifying limited volumes of sperm suspensions, such approach is yet solely academic in nature. Semen for breeding ought to be frozen conventionally, albeit with a focus on increased cell lifespan, and managing concentrated semen doses for deep intrauterine AI. There is much yet to be learned from the ejaculate and the relationships between specific components of the seminal plasma and sperm function.

## 7. Acknowledgements

The studies of the author have been made possible by grants from the Swedish Research Council Formas, the Swedish Farmer's Foundation for Agricultural Research (SLF), and The Swedish Research Council (VR), Stockholm, Sweden.

## 8. References

- Arav A, Yavin S, Zeron Y, Natan D, Dekel I, Gacitua H (2002) New trends in gamete's cryopreservation. *Mol Cell Endocrinol* 187: 77-81.
- Arav A, Natan Y (2009) Directional freezing: a solution to the methodological challenges to preserve large organs. *Semin Reprod Med* 27: 438-442.
- Bathgate R, Eriksson B, Maxwell WMC, Evans G (2005) Low dose deep intrauterine insemination of sows with fresh and frozen-thawed spermatozoa. *Theriogenology* 63: 553-554.
- Bathgate R, Maxwell WMC, Evans G (2007) Effects of platelet-activating factor and platelet activating factor acetylhydrolase on in vitro post-thaw boar sperm parameters. *Theriogenology* 67 886-892.
- Beebe LFS, Cameron RDA, Blackshaw AW, Keates HL (2005) Changes to porcine blastocyst vitrification methods and improved litter size after transfer. *Theriogenology* 64: 879-890.
- Bernshtein AD, Petropavloski VV (1937) Influence of non-electrolytes on viability of spermatozoa. *Bull Exp Biol Med* III: 21-25.
- Berthelot F, Martinat-Botte F, Locatelli A, Perreau C, Terqui M (2000) Piglets born after vitrification of embryos using the Open Pulled Straw method. *Cryobiology* 41:116-124.
- Berthelot F, Martinat-Botté F, Perreau C, Terqui M (2001) Birth of piglets after OPS vitrification and transfer of compacted morula stage with intact zona pellucida. *Reprod Nutr Dev* 41: 267-272.
- Berthelot F, Martinat-Botte F, Vajta G, Terqui M (2003) Cryopreservation of porcine embryos: state of the art. *Livest Prod Sci* 83: 73-83.
- Bianchi I, Calderam K, Maschio EF, Madeira EM, da Rosa Ulguim R, Corcini CD, Bongalhardo DC, Correa EK, Lucia T Jr, Deschamps JC, Correa MN (2008) Evaluation of amides and centrifugation temperature in boar semen cryopreservation. *Theriogenology* 69: 632-638.
- Bolarín A, Roca J, Rodriguez-Martinez H, Hernandez M, Vazquez JM, Martínez EA (2006) Dissimilarities in sows' ovarian status at the insemination time could explain differences in fertility between farms when frozen-thawed semen is used. *Theriogenology*, 65, 669-680.
- Borges EN, Silva RC, Futino DO, Rocha-Junior CM, Amorim CA, Bão SN, Lucci CM (2009) Cryopreservation of swine ovarian tissue: effect of different cryoprotectants on the structural preservation of preantral follicle oocytes. *Cryobiology* 59:195-200.
- Bredkjaer HE, Grudzinskas JG (2001) Cryobiology in human assisted reproductive technology. Would Hippocrates approve? *Early Pregnancy* 5: 211-213.
- Buranaamnuay K, Grossfeld R, Struckmann C, Rath D (2011) Influence of cryoprotectants glycerol and maides, combined with antioxidants on quality of frozen-thawed boar semen. *Anim Reprod Sci* 127: 56-61.
- Buranaamnuay K, Tummaruk P, Singlor J, Rodriguez-Martinez H, Techakumphu M (2009) Effects of straw volume and Equex-STM® on boar sperm quality after cryopreservation. *Reprod Domest Anim* 44: 69-73.

- Bussiere JF, Bertaud G, Guillouet P (2000) Conservation of boar semen by freezing. Evaluation in vitro and after insemination. 32èmes Journées de la Recherche Porcine en France 32: 429-432.
- Bwanga CO, Einarsson S, Rodriguez-Martinez H (1991a) Freezing of boar semen in plastic bags and straws. *Reprod Domest Anim* 26 117-125.
- Bwanga CO, Ekwall H, Rodriguez-Martinez H (1991b) Cryopreservation of boar semen: III-Ultrastructure of boar spermatozoa frozen ultra-rapidly at various stages of conventional freezing/thawing. *Acta Vet Scand* 32 463-471.
- Cameron RDA, Beebe LFS, Blackshaw AW, Higgins A, Nottle MB (2000) Piglets born from vitrified early blastocysts using a simple technique. *Austr Vet J* 78: 195-196.
- Cameron RDA, Beebe LFS, Blackshaw AW, Keates HL (2004) Farrowing rates and litter size following transfer of vitrified porcine embryos into a commercial swine herd. *Theriogenology*, 61, 1533-1543.
- Crabo B, Einarsson S (1971) Fertility of deep frozen boar spermatozoa. *Acta Vet Scand* 12: 125-127.
- Cuello C, Berthelot F, Martinat-Botte F, Venturi E, Guillouet P, Vazquez JM, Roca J, Martinez EA (2005) Piglets born after non-surgical deep intrauterine transfer of vitrified blastocysts in gilts. *Anim Reprod Sci* 85: 275-286.
- Cuello C, Gil MA, Parrilla I, Tornel J, Vazquez JM, Roca J, Berthelot F, Martinat-Botte F, Martinez EA (2004a) Vitrification of porcine embryos at various developmental stages using different ultra-rapid cooling procedures. *Theriogenology* 62: 353-361.
- Cuello C, Gil MA, Parrilla I, Tornel J, Vazquez JM, Roca J, Berthelot F, Martinat-Botte F, Martinez EA (2004b) In vitro development following one-step dilution of OPS-vitrified porcine blastocysts. *Theriogenology* 62: 1144-1152.
- Cuello C, Gil MA, Almiñana C, Sanchez-Osorio J, Parrilla I, Caballero I, Vazquez JM, Roca J, Rodriguez-Martinez H, Martinez EA (2007) Vitrification of in vitro cultured porcine two-to-four cell embryos. *Theriogenology* 68: 258-264.
- Cuello C, Martinez E, Sanchez-Osorio J, Almiñana C, Gil MA, Caballero I, Parrilla I, Roca J, Vazquez JM, Rodriguez-Martinez H (2008) Super Open Pulled Straw Vitrification of Porcine Blastocysts: Effect of Centrifugation and Cytoskeletal Stabilization. *Biol Reprod SI-2008*: 114-115 (Proc 41st SSR Annual Meeting, May 27-30, 2008, Kailua-Kona, Hawaii, SSRABSTRACTS/2008/007187 Nr 262).
- Cuello C, Sanchez-Osorio J, Almiñana C, Gil MA, Parrilla I, Roca J, Vazquez JM, Martinez EA, Rodriguez-Martinez H (2010) Superfine open pulled straws vitrification of porcine blastocysts does not require pretreatment with cytochalasin B and/or centrifugation. *Reprod Fert Dev* 22: 808-817.
- Curaba M, Poels J, van Langendonck A, Donnez J, Wyns C (2011) Can prepubertal human testicular tissue be cryopreserved by vitrification? *Fertil Steril* 95: 2123 e9-12.
- De Mercado E, Hernandez M, Sanz E, Rodriguez A, Gomez E, Vazquez JM, Martinez EA, Roca J (2009) Evaluation of L-glutamine for cryopreservation of boar spermatozoa. *Anim Reprod Sci* 115: 149-157.
- Devireddy RV, Fahrig B, Godke RA, Leibo SP (2004) Subzero water transport characteristics of boar spermatozoa confirm observed optimal cooling rates. *Mol Reprod Dev* 67: 446-457.

- Díaz-García C, Johannesson L, Enskog A, Tzakis A, Olausson M, Brännström M (2011) Uterine transplantation research: laboratory protocols for clinical application. *Mol Hum Reprod* (in press)
- Dittrich R, Maltaris T, Mueller A, Dimmler A, Hoffmann I, Kiesewetter F, Beckmann MW (2006) Successful uterus cryopreservation in an animal model. *Horm Metab Res* 38: 141-145.
- Dittrich R, Beckmann MW, Mueller A, Binder H, Maltaris T (2010) Uterus cryopreservation: maintenance of uterine contractility by the use of different cryoprotocols. *Reprod domest Anim* 45: 86-91.
- Dobrinsky JR (2001) Cryopreservation of pig embryos: adaptation of vitrification technology for embryo transfer. *Reproduction* 58: 325-333.
- Dobrinsky JR, Nagashima H, Pursel VG, Schreier LL, Johnson LA (2001) Cryopreservation of morula and early blastocyst stage swine embryos: Birth of litters after transfers. *Theriogenology* 55: 303.
- Dobrinsky JR, Pursel VG, Long CR, Johnson LA (2000) Birth of piglets after transfer of embryos cryopreserved by cytoskeletal stabilization and vitrification. *Biol Reprod* 62: 564-570.
- Dobrinsky JR (1997) Cryopreservation of pig embryos. *J Reprod Fertil* 52: 301-312.
- Dong Q, Correa LM, VandeVoort CA (2009) Rhesus monkey sperm cryopreservation with TEST-yolk extender in the absence of permeable cryoprotectant. *Cryobiology* 58: 20-27.
- Du Y, Pribenszky CS, Molnar M, Zhang X, Yang H, Kuwayama M, Pedersen AM, Villemoes K, Bolund L, Vajta G (2008) High hydrostatic pressure: a new way to improve in vitro developmental competence of porcine matured oocytes after vitrification. *Reproduction* 135: 13-17.
- Ekwall H (2009) Cryo-scanning electron microscopy discloses differences in dehydration of frozen boar semen stored in large containers. *Reprod Domest Anim* 44 62-68.
- Ekwall H, Hernández M, Saravia F & Rodríguez-Martínez H (2007) Cryo-scanning electron microscopy (Cryo-SEM) of boar semen frozen in medium-straws and MiniFlatPacks. *Theriogenology* 67: 1463-1472.
- Eriksson BM, Rodríguez-Martínez H (2000) Deep freezing of boar semen in plastic film "Cochettes". *J Vet Med A* 47: 89-97.
- Eriksson BM, Rodríguez-Martínez H (2000) Effect of freezing and thawing rates on the post-thaw viability of boar spermatozoa frozen in large 5 ml packages (FlatPack). *Anim Reprod Sci* 63: 205-220.
- Eriksson BM, Petersson H, Rodríguez-Martínez H (2002) Field fertility with exported boar semen frozen in the new FlatPack container. *Theriogenology* 58: 1065-1079.
- Esaki R, Ueda H, Kurome M, Hirakawa K, Tomii R, Yoshioka H, Ushijima H, Kurayama M, Nagashima H (2004) Cryopreservation of porcine embryos derived from in vitro-matures oocytes. *Biol Reprod* 71: 432-437.
- Flowers WL (1999) Artificial insemination, in animals. In: Knobil E, Neill JD (Eds) *Encyclopedia of Reproduction*. Vol I, Academic Press, San Diego: 291-302.
- Foote RH (1999) Development of reproductive biotechnologies in domestic animals from artificial insemination to cloning: a perspective. *Cloning* 1: 133-142.

- Fraser L, Dziekonska A, Strzezek R, Strzezek J (2007) Dialysis of boar semen prior to freezing-thawing: its effects on post-thaw characteristics. *Theriogenology* 67: 994-1003.
- Fraser L, Strzezek J (2007) Effect of different procedures of ejaculate collection, extenders and packages on DNA integrity of boar spermatozoa following freezing-thawing. *Anim Reprod Sci* 99: 317-329.
- Fraser L, Strzezek J, Kordan W (2011) Effect of freezing on sperm nuclear DNA. *Reprod domest Anim* 46 S2: 14-17.
- Fuller BJ (2004) Cryoprotectants: The essential antifreezes to protect life in the frozen state. *Cryo Letters* 25: 375-388.
- Gandolfi F, Paffni A, Papasso Brambilla E, Bonetti S, Brevini TAL, Ragni G (2006) Efficiency if equilibrium cooling and vitrification procedures for the cryopreservation of ovarian tissue: comparative analysis between human and animal models. *Fertil Steril* 85 S1: 1150-1156.
- Gajda B (2009) Factors and methods of pig oocyte and embryo quality improvement and their application in reproductive biotechnology. *Reprod Biol* 9: 97-112.
- Gil MA, Roca J, Cremades T, Hernandez M, Vazquez JM, Rodriguez-Martinez H, Martinez EA (2005) Does multivariate analysis of post-thaw sperm characteristics accurately estimate in vitro fertility of boar individual ejaculates? *Theriogenology* 64: 305-316.
- Graham EF, Rajamannan AHJ, Schmehl MKL, Maki-Laurila M, Re B (1971) Preliminary report on procedure and rationale for freezing boar spermatozoa. *AI Digest* 19: 12-14.
- Guthrie HD, Welch GR (2005) Impact of storage prior to cryopreservation on plasma membrane function and fertility of boar sperm. *Theriogenology* 63: 396-410.
- Gutierrez-Perez O, Juarez-Mosqueda Mde L, Carvajal SU, Ortega ME (2009) Boar spermatozoa cryopreservation in low glycerol/trehalose enriched freezing media improves cellular integrity. *Cryobiology* 58: 287-292.
- Han B, Bischof JC (2004a) Direct cell injury associated with eutectic crystallization during freezing. *Cryobiology* 48: 8-21.
- Han B & Bischof JC (2004b) Thermodynamic nonequilibrium phase change behaviour and thermal properties of biological solutions for cryobiology applications. *J Biochem Eng* 126: 196-203.
- Hayashi S, Kobayashi K, Mizuno J, Saitoh S (1989) Birth of piglets from frozen embryos. *Vet Record* 125: 43-44.
- Hernandez M, Ekwall H, Roca J, Vazquez JM, Martinez E, Rodriguez-Martinez H (2007b) Cryo-scanning electron microscopy (Cryo-SEM) of semen frozen in medium-straws from good and sub-standard freezer AI-boars. *Cryobiology* 54: 63-70.
- Hernandez M, Roca J, Ballester J, Vázquez JM, Martínez EA, Johannisson A, Saravia F, Rodriguez-Martinez H (2006) Differences in SCSA outcome among boars with different sperm freezability. *Int J Androl* 29: 583-591.
- Hernandez M, Roca J, Gil MA, Vázquez JM, Martínez EA (2007a) Adjustments on the cryopreservation conditions reduce the incidence of boar ejaculates with poor sperm freezability. *Theriogenology* 67: 1436-1445.

- Holm P, Vatja G, Machaty Z, Schmidt M, Prather RS, Greve T, Callesen H (1999) Open pulled straw (ops) vitrification of porcine blastocysts: simple procedure yielding excellent in vitro survival, but so far no piglets following transfer. *CryoLetters* 20: 307-310.
- Holt WV (2000a) Fundamental aspects of sperm cryobiology: the importance of species and individual differences. *Theriogenology* 53: 47-58.
- Holt WV (2000b) Basic aspects of frozen storage of semen. *Anim Reprod Sci* 62: 3-22.
- Holt WV, Medrano A, Thurston LM, Watson PF (2005) The significance of cooling rates and animal variability for boar sperm cryopreservation: insights from the cryomicroscope. *Theriogenology* 15: 370-382.
- Hossain AM, Osuamkpe CO (2007) Sole use of sucrose in human sperm cryopreservation. *Arch androl* 53: 99-103.
- Hossain MdS, Johannisson A, Pimenta Siqueira A, Wallgren M, Rodriguez-Martinez H (2011) Spermatozoa in the sperm-peak-fraction of the boar ejaculate show a lower flow of Ca<sup>2+</sup> under capacitation conditions post-thaw which might account for their higher membrane stability after cryopreservation. *Anim Reprod Sci* 128: 37-44.
- Hu JH, Li QW, Jiang ZL & Li WY (2008) Effects of different extenders on DNA integrity of boar spermatozoa following freezing-thawing. *Cryobiology* 57: 257-262.
- Hu JH, Li QW, Jiang ZL, Yang H, Zhang SS, Zhao HW (2008) The cryoprotective effect of trehalose supplementation on boar spermatozoa quality. *Reprod domest Anim* 44: 571-575.
- Imhof M, Hofstetter G, Bergmeister H, Rudas M, Kain R, Lipovac M, Huber J (2004) Cryopreservation of a whole ovary as a strategy for restoring ovarian function. *J Assist Reprod Genet* 21: 459-65.
- Isachenko V, Folch J, Isachenko E, Nawroth F, Krivokharchenko D, Vajta G, Dattena M, Alabart JL (2003) Double vitrification of rat embryos at different developmental stages using an identical protocol. *Theriogenology*, 60, 445-452.
- Isachenko E, Isachenko V, Katkov II, Rahimi G, Schondorf T, Mallmann P, Dessole S, Nawroth F (2004) DNA integrity and motility of human spermatozoa after standard slow freezing versus cryoprotectant-free vitrification. *Human Reprod* 19: 932-939.
- Isachenko E, Isachenko V, Montag M, Zaeva V, Kriokharchenko A, Nawroth F, Dessole S, Katkov I, van der Ven H (2005) Clean technique for cryoprotectant-free vitrification of human spermatozoa. *Reprod Biomed Online* 10: 350-354.
- Isachenko E, Isachenko V, Weiss JM, Kreienberg R, Katkov II, Schulz M, Lulat AGMI, Risopatron MJ, Sanchez R (2008) Acrosomal status and mitochondrial activity of human spermatozoa vitrified with sucrose. *Reproduction* 136: 167-173.
- Isachenko E, Maettner R, Petrunkina AM, Sterzik K, Mallmann P, Rahimi G, Sanchez R, Risopatron J, Damjanoski I, Isachenko E (2011) Vitrification of human ICSI/IVF spermatozoa without cryoprotectants: new capillary technology. *J Androl* (in press).
- Isachenko V, Lapidus I, Isachenko E, Krivokharchenko A, Kreienberg R, Woriedh M, Bader M, Weiss JM (2009) Human ovarian tissue vitrification versus conventional freezing: morphological, endocrinological, and molecular biological evaluation. *Reproduction* 138: 319-327.

- Jeong YJ, Kin MK, Song HJ, Kang EJ, Ock SA, Kumar BM, Balasubramanian S, Rho GJ (2009) Effect of lpha-tocopherol supplementation during boar semen cryopreservation on sperm characteristics and expression of apoptosis related genes. *Cryobiology* 58: 181-189.
- Jiang ZL, Li QW, Li WY, Hu JH, Zhao HW, Zhang SS (2007) Effect of low density lipoproteins on DNA integrity of freezing-thawing boar sperm by neutral comet assay. *Anim Reprod Sci* 99 401-407.
- Johnson LA, Weitze KF, Fiser P, Maxwell WM (2000) Storage of boar semen. *Anim Reprod Sci* 18 143-172.
- Juarez JD, Parrilla I, Vazquez JM, Martinez EA, Roca J (2011) Boar semen can tolerate rapid cooling rates prior to freezing. *Reprod Fertil Dev* 23: 681-690.
- Kaeoket K, Chanapiwat P, ummaruk P, Techakumphu M (2010) Supplemental effect of varying L-cysteine concentrations on the quality of cryopreserved boar semen. *Asian J Androl* 12: 760-765.
- Karosas J, Rodriguez-Martinez H (1993) Use of two detergents for freezing of boar semen in plastic bags. *Biomed Res* 4: 125-136.
- Kawakami M, Kato Y, Tsunoda Y (2008) The effects of time of first cleavage, developmental stage, and delipidation of nuclear-transferred porcine blastocysts on survival following vitrification. *AnimReprod Sci* 106: 402-411.
- Keros V, Rosenlund B, Hultenby K, Aghajanova L, Levkov L, Hovatta O (2005) Optimizing cryopreservation of human testicular tissue: comparison of protocols with glycerol, propanediol and dimethylsulphoxide as cryoprotectants. *Hum Reprod* 20: 1676-1787.
- Kim SS (2010) Time to re-think: ovarian tissue transplantation versus whole ovary transplantation. *Reprod Biomed Online* 20: 171-174.
- Knox RV (2011) The current value of frozen-thawed boar semen for commercial companies. *Reprod Domest Anim* 46 S2: 4-6.
- Kobayashi S, Takei M, Kano M, Tomita M, Leibo SP (1998) Piglets produced by transfer of vitrified porcine embryos after stepwise dilution of cryoprotectants. *Cryobiology* 36: 20-31.
- Kumar S, Millar JD, Watson PF (2003) The effect of cooling rate on the survival of cryopreserved bull, ram and boar spermatozoa: a comparison of two controlled-rate cooling machines. *Cryobiology* 46: 246-253.
- Lane M, Schoolcraft WB, Gardner DK (1999) Vitrification of mouse and human blastocysts using a novel cryoloop container-less technique. *Fertil Steril* 72: 1073-1078.
- Li N, Lai L, Wax D, Hao Y, Murphy CN, Rieke A, Samuel M, Linville ML, Korte SW, Evans RW, Turk JR, Kang JX, Witt WT, Dai Y, Prather RS (2006) Cloned transgenic swine via in vitro production and cryopreservation. *Biol Reprod* 75: 226-230.
- Lin L, Kragh PM, Kuwayama M, Du Y, Zhang X, Yang H, Bolund L, Callesen H, Vajta G (2008) Osmotic stress induced by sodium chloride, sucrose or threhalose improves cryotolerance and developmetnalcompetence of porcine oocytes. *Reprod Fertil Dev* 21: 338-344.



- Malo C, Gil L, Gonzalez N, Cano R, de Blas I, Espinosa E (2010) Comparing sugar type supplementation for cryopreservation of boar semen in egg yol-based extender. *Cryobiology* 61: 17-21.
- Martinat-Botte F, Berthelot F, Plat M, Madec F (2006) Cryopreservation and transfer of pig in vivo embryos: state of the art. *Gynecol Obstét Fert* 34: 754-759.
- Massip A (2001) Cryopreservation of embryos of farm animals. *Reprod Domest Anim* 36: 49-55.
- Mazur P, Cole KW (1989) Roles of unfrozen fraction, salt concentration, and changes in cell volume in the survival of slowly frozen human erythrocytes. *Cryobiology* 26: 1-29.
- Mazur P, Leibo SP, Seidel GE Jr (2008) Cryopreservation of the germplasm of animals used in biological and medical research: importance, impact, status, and future directions. *Biol Reprod* 78: 2-12.
- Medrano A, Holt WV, Watson PF (2009) Controlled freezing studies on boar sperm cryopreservation. *Andrologia* 41: 246-250.
- Meng X, Gu X, Wu C, Dai J, Zhang , Xie Y, Wu Z, Liu L, Ma H, Zhang D (2010) Effect of trehalose on the free-dried boar spermatozoa. *Sheng Wu Gong Cheng Xue Bao* 26: 1143-1149.
- Mocé E, Blanch E, Tomás C, Graham JK (2010) Use of cholesterol in sperm cryopreservation: present moment and perspectives to future. *Reprod Domest Anim* 45: 57-66.
- Moniruzzaman M, Bao RM, Taketsuru H, Miyano T (2009) Development of vitrified porcine primordial follicles in xenografts. *Theriogenology* 72: 280-288.
- Moore HDM, Hibbitt KG (1977) Fertility of boar spermatozoa after freezing in the absence of seminal vesicular proteins. *J Reprod Fert* 50: 349-352.
- Morris GJ (2006) Rapidly cooled human sperm: no evidence of intracellular ice formation. *Human Reprod* 21: 2075-2083.
- Morris GJ, Acton E, Avery S (1999) A novel approach to sperm cryopreservation. *Human Reprod* 14: 1013-1021.
- Morris GJ, Goodrich M, Acton E, Fonseca F (2006) The high viscosity encountered during freezing in glycerol solutions: effects on cryopreservation. *Cryobiology* 52: 323-334.
- Morris GJ, Faszer K, Green JE, Raper D, Grout BWW, Fonseca F (2007) Rapidly cooled horse spermatozoa: loss of viability is due to osmotic imbalance during thawing, not intracellular ice formation. *Theriogenology* 68: 804-812.
- Mwanza A, Rodriguez-Martinez H (1993) Post-thaw motility, acrosome morphology and fertility of deep frozen boar semen packaged in plastic PVC-bags. *Biomed Res* 4 21-29.
- Nagashima H, Kashiwazaki N, Ashman RJ, Grupen CG, Nottle MB (1995) Cryopreservation of porcine embryos. *Nature* 374: 416.
- Nagashima H, Kashiwazaki N, Ashman RJ, Grupen CG, Seamark RF, Nottle MB (1994) Removal of cytoplasmic lipid enhances the tolerance of porcine embryos to chilling. *Biol Reprod* 51: 618-622.
- Nagashima H, Kuwayama M, Grupen CG, Ashman RJ, Nottle MB (1996) Vitrification of porcine early cleavage stage embryos and oocytes after removal of cytoplasmic lipid droplets. *Theriogenology* 45: 180.

- Nagashima H, Hiruma K, Saito H, Tomii R, Ueno S, Nakayama N, Matsunari H, Kurome M (2007) Production of live piglets following cryopreservation of embryos derived from in vitro-matured oocytes. *Biol Reprod* 76: 900-905.
- Niimura S, Ishida K (1980) Histochemical observation of lipid droplets in mammalian eggs during the early development. *Jap J Animal Reprod* 26: 46-49.
- Ogawa B, Ueno S, Nakayama N, Matsunari H, Nakano K, Fujiwara T, Ikezawa Y, Nagashima H (2010) Developmental ability of porcine in vitro matured oocytes at the meiosis II stage after vitrification. *J Reprod Dev* 56: 356-361.
- Ohanian C, Rodriguez H, Piriz H, Martino I, rieppi G, Garofalo EG, Roca RA (1979) Studies on the contractile activity and ultrastructure of the boar testicular capsule. *J Reprod Fertil* 57: 79-85.
- Ortman K, Rodriguez-Martinez H (1994) Membrane damage during dilution, cooling and freezing-thawing of boar spermatozoa packaged in plastic bags. *J Vet Med A* 41: 37-47.
- Parrilla I, Vazquez JM, Caballero I, Gil MA, Hernandez M, Roca J, Lucas X, Martinez EA (2009) Optimal characteristics of spermatozoa for semen technologies in pigs. *Soc Reprod Fertil* S66: 37-50.
- Pegg DE (2002) The history and principles of cryopreservation. *Semin Reprod Med* 20: 5-13.
- Pegg DE (2005) The role of vitrification techniques of cryopreservation in reproductive medicine. *Hum Fertil (Camb)* 8: 231-239.
- Pegg DE (2007) Principles of cryopreservation. *Methods Mol Biol* 368: 39-57.
- Penfold LM, Watson PF (2001) The cryopreservation of gametes and embryos of cattle, sheep, goats and pigs. In: (Watson PF, Holt WV (Eds.) *Cryobanking the Genetic Resource*. New York, NY: Taylor & Francis: 279-316.
- Peña FJ, Johannisson A, Wallgren M, Rodriguez-Martinez H (2003) Antioxidant supplementation in vitro improves boar sperm motility and mitochondrial membrane potential after cryopreservation of different fractions of the ejaculate. *Anim Reprod Sci* 78: 85-98.
- Peña FJ, Johannisson A, Wallgren M, Rodriguez-Martinez H (2004a) Antioxidant supplementation of boar spermatozoa from different fractions of the ejaculate improves cryopreservation: changes in sperm membrane lipid architecture. *Zygote* 12: 117-124.
- Peña FJ, Johannisson A, Wallgren M, Rodriguez Martinez H (2004b) Effect of hyaluronan supplementation on boar sperm motility and membrane lipid architecture status after cryopreservation. *Theriogenology* 61: 63-70.
- Pimenta Siqueira A, Wallgren M, Johannisson A, Md Hossain, Rodriguez-Martinez H (2011) Quality of boar spermatozoa from the sperm-peak portion of the ejaculate after simplified freezing in MiniFlatpacks compared to the remaining spermatozoa of the sperm-rich fraction. *Theriogenology* 75:1175-1184.
- Polge C (1956) Artificial Insemination in Pigs. *Vet Record* 68: 62-76.
- Pursel VG, Johnson LA (1971) Procedure for the preservation of boar spermatozoa by freezing. *USDA, ARS Bulletin Notes* 44-227: 1-5.
- Rall WF, Fahy GM (1985) Ice-free cryopreservation of mouse embryos at -196°C by vitrification. *Nature* 313: 573-575.

- Rath D, Niemann H (1997) In vitro fertilization of porcine oocytes with fresh and frozen-thawed epididymal semen obtained from identical boars. *Theriogenology* 47: 785-793.
- Rath D, Bathgate R, Rodriguez-Martinez H, Roca J, Strzezek J, Waberski D (2009) Recent advances in boar semen cryopreservation. In: "Control of Pig Reproduction VIII" Rodriguez-Martinez H, Vallet JL, Ziecik AJ (Eds). Nottingham University Press, UK: 51-66 (ISBN 978-1-904761-39-6).
- Riesenbeck A (2011) Review on international trade with boar semen. *Reprod Domest Anim* 46 S2: 1-3.
- Roca J, Gil MA, Hernandez M, Parrilla I, Vazquez JM, Martinez EA (2004) Survival and fertility of boar spermatozoa after freeze-thawing in extender supplemented with butylated hydroxytoluene. *J Androl* 25: 397-405.
- Roca J, Rodríguez MJ, Gil MA, Carvajal G, García EM, Cuello C, Vázquez JM, Martínez EA (2005) Survival and in vitro fertility of boar spermatozoa frozen in the presence of superoxide dismutase or catalase or both. *J Androl* 26: 15-24.
- Roca J, Hernández M, Carvajal G, Vazquez JM, Martinez EA (2006a) Factors influencing boar sperm cryosurvival. *J Anim Sci* 84: 2692-2699.
- Roca J, H Rodriguez-Martinez, JM Vazquez, A Bolarín, M Hernandez, F Saravia, M Wallgren, Martínez EA (2006b) Strategies to improve the fertility of frozen-thawed boar semen for artificial insemination. In: Control of Pig Reproduction VII, Ashworth CJ, Kraeling RR (eds), Nottingham Univ. Press, Manor Farm, Thrumpton, UK: 261-275 (Soc Reprod Fert Suppl 62).
- Roca J, Parrilla I, Rodriguez-Martinez H, Gil MA, Cuello C, Vazquez JM, Martinez EA (2011) Approaches towards efficient use of boar semen in the pig industry. *Reprod Domest Anim* 46 S2: 79-83.
- Rodriguez-Martinez H (2007a) State of the art in farm animal sperm evaluation. *Reprod Fert Dev* 19: 91-101.
- Rodriguez-Martinez H (2007b) Reproductive biotechnology in pigs: what will remain? In: "Paradigms in pig science". Wiseman J, Varley MA, McOrist S, Kemp B (eds), Nottingham University Press, Nottingham, UK, Chapter 15: 263-302 (ISBN 978-1-904761-56-3).
- Rodriguez-Martinez H, Barth AD (2007) In vitro evaluation of sperm quality related to in vivo function and fertility. In: Reproduction in Domestic Ruminants VI. Juengel JL, Murray JF, Smith MF (eds), Nottingham University Press, Nottingham, UK: 39-54 (Soc Reprod Fert 64: 39-54, 2007).
- Rodríguez-Martinez H, Saravia F, Wallgren M, Roca J, Peña FJ (2008) Influence of seminal plasma on the kinematics of boar spermatozoa during freezing. *Theriogenology* 70: 1242-1250.
- Rodriguez-Martinez H, Kvist U, Saravia F, Wallgren M, Johannisson A, Sanz L, Peña FJ, Martinez EA, Roca J, Vazquez JM, Calvete JJ (2009) The physiological roles of the boar ejaculate. In: "Control of Pig Reproduction VIII" Rodriguez-Martinez H, Vallet JL, Ziecik AJ (eds), Nottingham University Press, UK: 1-21
- Rodriguez-Martinez H, Wallgren M (2011a) Advances in boar semen cryopreservation. *Vet Med Int* 2011, Article ID 396181, 5pp (doi:10.4061/2011/396181), open access.

- Rodriguez-Martinez H, Kvist U, Ernerudh J, Sanz L, Calvete JJ (2011b) Seminal plasma proteins: what role do they play? *Am J Reprod Immunol (AJRI)* 66 S1: 11-22.
- Sanchez R, Risopatron J, Schulz M, Villegas J, Isachenko V, Kreienberg R, Isachenko E (2011) Canine sperm vitrification with sucrose: effect on sperm function. *Andrologia* 43: 233-241.
- Sanchez-Osorio J, Cuello C, Gil MA, Parrilla I, Maside C, Almiñana C, Lucas X, Roca J, Vazquez JM, Martinez EA (2010) Vitrification and warming of in vivo-derived porcine embryos in a chemically defined medium. *Theriogenology* 73: 300-308.
- Sanchez-Osorio J, Cuello C, Gil MA, Parrilla I, Almiñana C, Caballero I, Roca J, Vazquez JM, Rodriguez-Martinez H, Martinez EA (2010) In vitro post-warming viability of vitrified porcine embryos: Effect of cryostorage length. *Theriogenology* 74: 486-490.
- Saravia F, Wallgren M, Nagy S, Johannisson A, Rodríguez-Martínez H (2005) Deep freezing of concentrated boar semen for intra-uterine insemination: effects on sperm viability. *Theriogenology* 63: 1320-1333.
- Saravia F, Hernández M, Wallgren MK, Johannisson A & Rodríguez-Martínez H (2007) Cooling during semen cryopreservation does not induce capacitation of boar spermatozoa. *Int J Androl* 30: 485-499.
- Saravia F, Wallgren M, Johannisson A, Calvete JJ, Sanz L, Peña FJ, Roca J, Rodríguez-Martínez H (2009) Exposure to the seminal plasma of different portions of the boar ejaculate modulates the survival of spermatozoa cryopreserved in MiniFlatPacks. *Theriogenology* 71: 662-675.
- Saravia F, Wallgren M, Rodríguez-Martínez H (2010) Freezing of boar semen can be simplified by handling a specific portion of the ejaculate with a shorter procedure and MiniFlatPack packaging. *Anim Reprod Sci* 117: 279-287.
- Saragusty J, Arav A (2011) Current progress in oocyte and embryo cryopreservation by slow freezing and vitrification. *Reproduction* 141: 1-19.
- Saragusty J, Gacitua H, Pettit MT, Arav A (2007) Directional freezing of equine semen in large volumes. *Reprod Domest Anim* 42: 610-615.
- Saragusty J, Gacitua H, Rozenboim I, Arav A (2009) Do physical forces contribute to cryodamage? *Biotechnol Bioeng* 104: 719-728.
- Shaw JM, Trounson AO (2002) Ovarian tissue transplantation and cryopreservation: its application to the maintenance and recovery of transgenic mouse. In: *Methods in Molecular biology*, vol 180 Ch 11: 229-251 "Transgenesis techniques: Principles and Protocols" 2nd Ed, Clark A (ed) Humana press Totowa.
- Shi LY, Jin HF, Kim JG, Mohana Kumar B, Balasubramanian S, Choe SY, Rho GJ (2007) Ultra-structural changes and developmental potential of porcine oocytes following vitrification. *Anim Reprod Sci* 100: 128-140.
- Somfai T, Kashiwazaki N, Ozawa M, Nakai M, Maedomari N, Noguchi J, Kaneko H, Nagai T, Kikuchi K (2008) Effect of centrifugation treatment before vitrification on the viability of porcine mature oocytes and zygotes produced in vitro. *J Reprod Dev* 54: 149-155.
- Somfai T, Noguchi J, Kaneko H, Nakai M, Ozawa M, Kashiwazaki N, Egerszegi I, Rátky J, Nagai T, Kikuchi K (2010) Production of good-quality porcine blastocysts by in

- in vitro fertilization of follicular oocytes vitrified at the germinal vesicle stage. *Theriogenology* 73: 147-156.
- Thurston LM, Holt WV, Watson PF (2003) Post-thaw functional status of boar spermatozoa cryopreserved using three controlled rate freezers: a comparison. *Theriogenology* 60: 101-113.
- Vajta G, Holm P, Greve T, Callesen H (1997) Vitrification of porcine embryos using the Open Pulled Straw (OPS) method. *Acta Vet Scand* 38: 349-352.
- Waterhouse KE, Hofmo PO, Tverdal A, Miller RR Jr (2006) Within and between breed differences in freezing tolerance and plasma membrane fatty acid composition of boar sperm. *Reproduction* 131: 887-894.
- Watson PF, Fuller BJ (2001) Principles of cryopreservation of gametes and embryos. In: Watson PF, Holt WV (Eds) *Cryobanking the Genetic Resource*. New York, NY: Taylor & Francis: 21-46.
- Weitze KF, Rath D, Baron G (1987) New aspects of preservation of boar sperm by deep freezing in plastic tubes. *Dtsch Tierärztl Wschr* 82: 261-267.
- Westendorf P, Richter L, Treu H (1975) Deep freezing of boar sperm. Laboratory and insemination results using the Hülsenberger paillette method. *Dtsch Tierärztl Wochenschr* 82: 261-267.
- Willadsen S, Polge C, Rowson LEA (1978) The viability of deep-frozen embryos. *J Reprod Fertil* 52: 391-393.
- Wilmut I (1972) The low temperature preservation of mammalian embryos. *J Reprod Fertil* 31: 513-514.
- Woelders H, Chaveiro A (2004) Theoretical prediction of "optimal" freezing programmes. *Cryobiology* 49: 258-271.
- Woelders H, Matthijs A, Zuidberg CA, Chaveiro AE (2005) Cryopreservation of boar semen: equilibrium freezing in the cryoscope and in straws. *Theriogenology* 63: 383-395.
- Wongtawan T, Saravia F, Wallgren M, Caballero I, Rodríguez-Martínez H (2006) Fertility after deep intra-uterine artificial insemination of concentrated low-volume boar semen doses. *Theriogenology* 65: 773-787.
- Wowk B (2010) Thermodynamic aspects of vitrification. *Cryobiology* 60: 11-22.
- Yavin S, Aroyo A, Roth Z, Arav A (2009) Embryo cryopreservation in the presence of low concentration of vitrification solution with sealed pulled straws in liquid nitrogen slush. *Human Reprod* 24: 797-804.
- Yi YJ, Cheon YM, Park CS (2002a) Effect of N-acetyl-D-glucosamine, and glycerol concentration and equilibrium time on acrosome morphology and motility of frozen-thawed boar sperm. *Anim Reprod Sci* 69: 91-97.
- Yi YJ, Im GS, Park CS (2002b) Lactose-egg yolk diluent supplemented with N-acetyl-D-glucosamine affect acrosome morphology and motility of frozen-thawed boar sperm. *Anim Reprod Sci* 74: 187-194.
- Yoneda A, Suzuki K, Mori T, Ueda J, Watanabe T (2004) Effects of delipidation and oxygen concentration on in vitro development of porcine embryos. *J Reprod Dev* 50: 287-295.
- Zeng WX, Terada T (2001) Effects of methyl-beta-cyclodextrin on cryosurvival of boar spermatozoa. *J Androl* 22: 111-118.

- Zhou GB, Li N (2009) Cryopreservation of porcine oocytes: recent advances. *Mol Hum Reprod* 15: 279-285.
- Zidovetzki R, Levitan I (2007) Use of cyclodextrins to manipulate plasma membrane cholesterol content: evidence, misconceptions and control strategies. *Biochim Biophys Acta* 1768: 1311-1324.

# Cryopreservation of Embryos from Model Animals and Human

Wai Hung Tsang and King L. Chow

*Division of Life Science, The Hong Kong University of Science and Technology  
Hong Kong*

## 1. Introduction

Diploidic germplasms such as embryos, compared to haploidic gametes, are theoretically a better choice for preservation of an animal species. However, there are significant challenges in cryopreservation of multicellular materials due to their size and physical complexity which affect the permeation of cryoprotectants and water, sensitivity to chilling and toxicity of cryoprotectants. While cryopreservation technologies are well developed and found feasible in embryos/larvae of some species, embryos of other species such as zebrafish failed to be cryopreserved. In addition, cryopreservation in many other emerging model organisms have not been developed at all. Hence, the limited cryopreservation technology has become a bottleneck in the development of various research areas, especially those relying on molecular genetics of emerging model organisms. Thorough understanding of the embryonic development and critical stages tolerant to cryopreservation needs to be identified so as to facilitate expansion of model systems available for specific biological and experimental interrogations.

## 1.2 Traditional and emerging animal models

Classical animal models, including species that represent major branches of the tree of life, are being used in biological studies. They include *Caenorhabditis elegans* (a nematode), *Drosophila melanogaster* (an arthropod), *Danio rerio* (a teleost fish), *Gallus gallus* (an avian), and *Mus musculus* (a mammal). They have been widely used in scientific research, primarily due to the ease of maintenance and specific features that facilitate experimental manipulations, genetic study and observation. As knowledge from these models has accumulated over the years, they offer important insights into the overall organization and functional composition of the general form of life. However, a comprehensive picture of variations of mechanistic innovation in the vast diversity of species in the Animal Kingdom is not available. Greater understanding of these organisms in different branches of the phylogenetic tree is in demand, in order to fill the gaps of existing findings. To meet this demand, more model organisms are emerging to provide unique perspectives of animal development and specific biological functions not yet uncovered in the study of other classical models. Emerging animal models include the brine shrimp *Artemia sinica*, starlet sea anemone *Nematostella vectensis*, non-parasitic flatworm *Planaria*, amphioxus *Branchiostoma floridae*, sea squirt *Ciona intestinalis*, sea lamprey *Petromyzon marinus*, Japanese

quail *Coturnix japonica*, opossum *Monodelphis domestica* and marmoset *Callithrix jacchus*, etc. For example, sea lampreys are cyclostomes in a basal group of vertebrates. Comparative studies on lamprey and jawed fish, e.g., zebrafish, reveal key elements guiding jaw evolution. Characteristics shared between lamprey and other vertebrates but absent in non-vertebrate chordates include the presence of neural crest cells and a jaw. Comparative studies can direct us to the origins of these features. Therefore, study of these emerging model organisms does offer a unique approach to understand the relatedness of species in the living world. Another example illustrating the importance of new model systems in studying the evolution of body plan is shown in Figure 1 (Kosik, 2009).

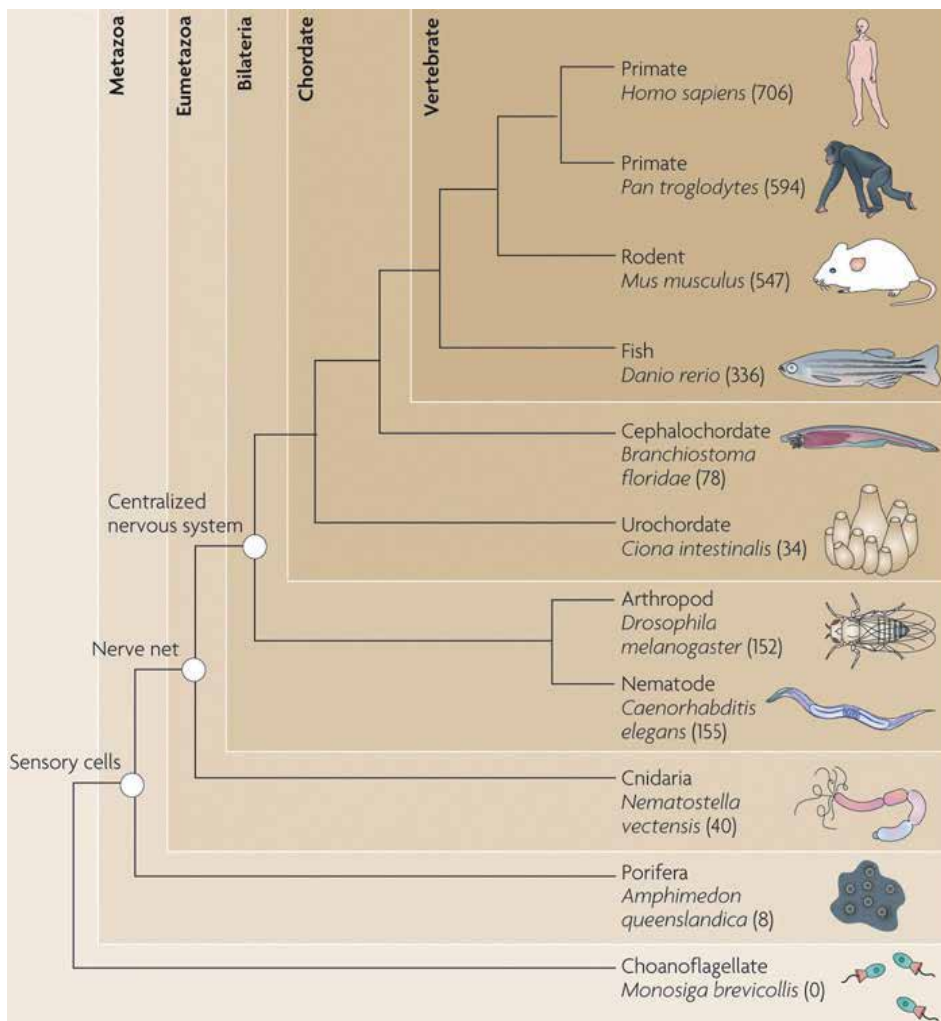

Fig. 1. The identification of miRNAs in different metazoan lineages revealed that the number of microRNAs (in brackets) is generally correlated with the complexity of body plan. Comparative studies involving “non-classical” model organisms further suggested a possible role of new microRNAs in evolutionary innovation. The figure is reproduced from Kosik (2009) with permission from the publisher.



### 1.3 Needs for cryopreservation

#### 1.3.1 Archives of genetic resources

Modern evolutionary developmental biology and molecular genetic studies on model organisms largely rely on manipulation of tissues and genomes. The advancement of technologies for genomic modification of these model organisms, in turn, affects the popularity of usage of particular model organisms. Eventually, this leads to a rapid increase in the number of transgenic/mutant strains in each popular species.

For the *Caenorhabditis* Genetic Center, mutants had been deposited by individual research groups and various genome wide mutagenesis projects such as the National BioResource Project for The Nematode and *Caenorhabditis elegans* Gene Knockout Consortium. In the National BioResource Project, random mutagenesis was performed for nematodes with UV in the presence of trimethylpsoralen. Affected genes are identified by screening with a gene-specific primer set (Gengyo-Ando & Mitani, 2000). As of April 2010, about 4,400 mutants were available and mutants of some 2800 genes were being screened. Without convenient procedures for cryopreserving these species, maintenance of these strains is a heavy burden to these centers, and in other laboratories using these mutants extensively for their studies. On the other hand, passaging parasitic nematode models in plants and in donor animals, e.g., *Cooperia oncophora* in the cattle host (Borgsteede & Hendriks, 1979), is particularly labor intensive and costly and poses risk of cross contamination.

At Bloomington *Drosophila* Stock Center, more than 30,000 strains of *Drosophila* are currently present. Preparations are in progress to expand the facility to hold up to 70,000 stocks in order to meet the needs of stocking transgenic strains to be generated for a wide range of studies, including those made by tissue specific knocking-out of genes for the modeling of human diseases. In Flybase, 112,278 fly stocks were recorded for 2011 (Flybase FB2011\_07 Release Notes).

In The Jackson Laboratory, over 4,000 mouse strains have been deposited and are available to the public. At the Medical Research Council Harwell and at The European Mouse Mutant Archive, over 1300 and 2200 mouse strains are stocked respectively (Eppig & Strivens, 1999). In various mouse stock centers in Japan, including BioResources Center (Riken) and Trans Genic Inc., about 8,000 mouse strains are stocked. More than 16,000 of the 24,954 protein coding genes in the mouse genome have been modified by the International Knockout Mouse Consortium (IKMC), as conditional knockout alleles in embryonic stem cells. So far, more than 1,000 mutant mice, each containing one of these conditional knockout alleles, are made available to the community. The ultimate goal is to generate different targeted alleles in embryonic stem cells (for targeted mice generation) or in targeted mice, to be available to the research community worldwide (Skarnes et al., 2011). On the other hand, about 1,200 zebrafish lines and about 100 *Xenopus* lines have been archived in the Zebrafish International Resource Center and European *Xenopus* Resource Centers, respectively.

Since keeping live animals is costly in terms of requirements of space, consumables and manpower, strains not being used need to be cryopreserved to reduce the running cost. It is, therefore, a very important technology that keeps various genome-wide knockout consortia affordable to average research laboratories.

### 1.3.2 Genetic stability control

The continuous passing of live animals in a small population may lead animal strains to accumulate spontaneous mutations and undergo genetic drift. In mouse, as an example of a lower mutation rate because of its relatively long life cycle, about 0.4 mutations are accumulated in each genome in each generation (Drake et al., 1998). Using this estimation, and assuming there are four generations per year, about ten mutations are accumulated in each descendent mouse diploid genome every 6.25 years (Tsang & Chow, 2010). After four years of sibling intercrosses, there is a 90% probability that more than one mutation can be fixed in a particular mouse line (Stevens et al., 2007). To circumvent this problem, the Jackson Laboratory (Bar Harbor, Maine, USA) adopted the Genetic Stability Program to refresh some mouse colonies with cryopreserved embryos once every five generations. This strategy aims at wiping out spontaneous mutations accumulated over time to ensure consistency of the mouse genome composition.

### 1.3.3 Genetic diversity maintenance

Maintaining genetic stability and diversity of wild parasitic nematodes collection is vital for research on parasite-host interactions, drug resistance and their applications. For example, prolonged passage of insecticidal nematodes (i.e. entomopathogenic nematodes) can cause a reduction of traits beneficial to pest control (Shapiro et al., 1996; Stuart & Gaugler, 1996; Wang & Grewal, 2002). Three continuous passages of *Galleria mellonella in vitro* resulted in a significant reduction in reproductive potential, and attenuated tolerance to heat, UV and desiccation (Wang & Grewal, 2002). These observations suggest that a selective pressure had been exerted on an isolated population that experienced continuous passages. The original genetic diversity in an isolated population will thus be largely reduced if cryopreservation is not practiced immediately after collection, before experimental analysis is performed.

### 1.3.4 Logistic advancement on assisted reproduction technologies

A traditional human *in vitro* fertilization cycle involves hormone induced ovarian stimulation for oocyte retrieval, *in vitro* fertilization, culture of embryos to blastocyst, selection of embryos and transfer of embryos into a recipient in an uninterrupted program. Surplus embryos are discarded. If the first pregnancy failed or another pregnancy is desired, the whole cycle has to be started again. Cryopreserving surplus embryos from the first round of the program can now be a backup for the second or more rounds of pregnancy. It can be done simply by transferring the thawed embryos to the recipients when the endometrial conditions are ready (Parriego et al., 2007).

In addition, for preimplantation genetic diagnosis programs, embryos must be transferred back to the mother at or younger than day-6 blastocysts, and so biopsies for prenatal diagnosis must be taken at the latest at day-6. More genetic materials (i.e. blastomeres or trophoblastic cells) can be obtained if the biopsy is performed later. However, accompanied shortcomings will be less time for genetic tests to be performed (Manipalviratn et al., 2009).

Cryopreservation of biopsied embryos can eliminate such conflicts between the quantity of biopsy material and the quality of genetic tests (as a function of available time; Figure 2). It has been demonstrated recently on mouse and then human embryos that biopsied embryos at various stages can survive cryopreservation well (Krzyminska & O'Neill, 1991; Wilton et al., 1989; Liu et al., 1993; Snabes et al., 1993; Zhang et al., 2009; Keskinetepe et al., 2009).

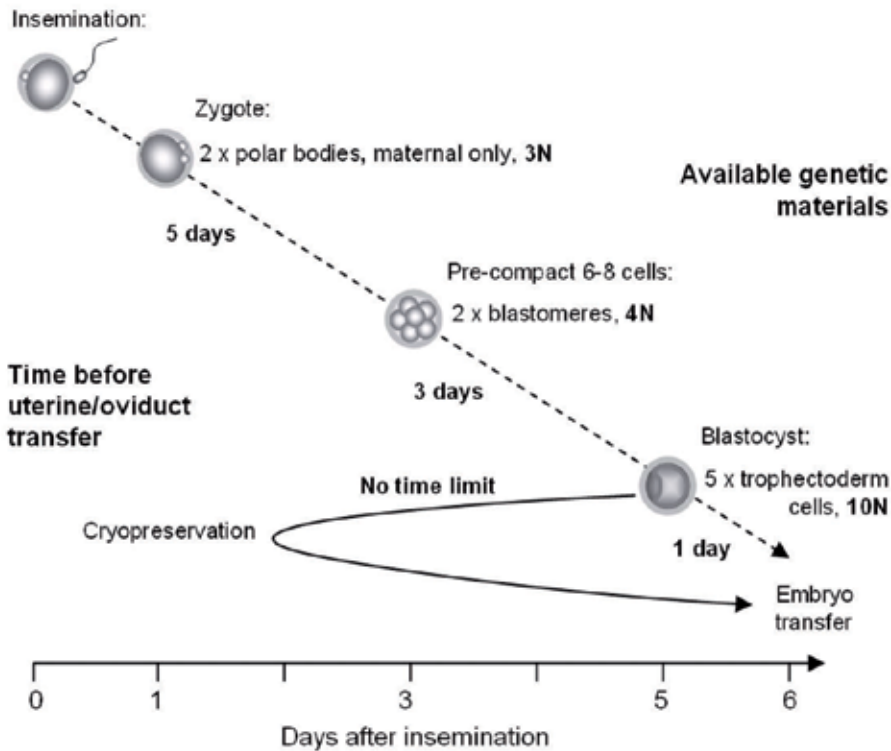

Fig. 2. Role of cryopreservation in assisted reproduction technology. Conflict between the time allowed for genetic diagnostic tests and the amount of genetic materials available (represented by the numbers of haploid genomes,  $N$ ) from biopsies at different embryonic stages exists in a continuous pre-implantation genetic diagnosis program (dashed arrow). The release of the time constraint by a cryopreservation cycle after blastocyst biopsy is denoted by the solid arrow.

## 2. Cryopreservation of mammalian preimplantation embryos

### 2.1 Mammalian pre-implantation embryos at different stages

The mammalian zygote (Figure 3D) is formed by fertilization of the oocyte by spermatozoa, normally in the oviduct. With advancement of the embryo culture technology, fertilization can be initiated outside the body (i.e. *in vitro* fertilization). The embryonic development continues up to hatched blastocysts, i.e. maximum of 4 days in mouse and 6 days in human, without compromising the development of the embryos after they are transferred into the recipient's uterus/oviduct. The preimplantation stage embryo is composed of a single cell or multiple blastomeres surrounded by an outer membrane called the zona pellucida, glycoprotein layer of a thickness of about  $6\mu\text{m}$  in mouse and  $8\mu\text{m}$  in human. The embryos have an outer diameter of about 0.10 mm in mouse and 0.12 mm in human. The volume enclosed by the mouse zona pellucida is limited to about 200  $\mu\text{l}$  and the diameter of the

cellular part of a mouse zygote is about 85 $\mu$ m (Zernicka-Goetz et al., 1997). In the presence of the perivitelline space, the cellular component is still in close contact with the zona pellucida, and is subjected to the immediate influence by the external medium due to the high permeability of the zona pellucida. The mouse embryo reaches two-cell stage and eight-cell stage at day 2 (dpc 1.5) and day 3 (dpc 2.5), respectively, after fertilization. Compaction usually occurs at day 3, causing a tight cell-cell association between the eight blastomeres to form a compact morula. At day 4 (dpc3.5), a blastocoel is evidenced as a cavity accumulated with fluid to form the blastocyst. The blastocoel expansion is limited by the non-growing zona pellucida. The blastocyst is composed of an embryonic inner cell mass and an extraembryonic trophoblast which immediately surrounds the expanding blastocoel. At day 4, the blastocyst hatches from a breach in the zona pellucida and attaches onto the endometrium for further development.

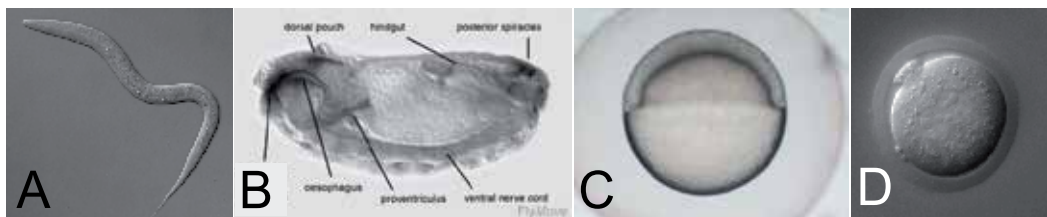

Fig. 3. Embryos and larva of model organisms to be cryopreserved. A, L1 stage larva of *C. elegans*; B, stage 15 (11-13hours) embryo of *Drosophila* (Weigmann et al., 2003); C, zebrafish at 50% epiboly; D, mouse embryo at zygote stage.

## 2.2 Cryoprotectant permeability of mammalian embryos

Prevention of ice formation by cryoprotectants is the key principle of protecting embryos from damage at cryogenic temperatures. To prevent intracellular ice formation, cryoprotectant molecules must penetrate the cells to exert intracellular cryoprotecting function. By measuring the changes in the volume of embryos immersed in cryoprotectant solutions (Emiliani et al., 2000), permeability of different cryoprotectant molecules at different developmental stages of preimplantation mouse embryos were compared (Table 1).

Embryos of different developmental stages show a differential permeating response to glycerol. The glycerol permeates compact morulae effectively and pre-compact 8-cell morulae moderately. One-cell embryos, 2-cell embryos and oocytes are virtually impermeable to glycerol. The highest permeability of embryos to cryoprotectant among all combinations is on compact morula to ethylene glycol. Acetamide also permeates at a relatively high degree in mouse 8-cell morulae but its permeability decreases dramatically in embryos at earlier developmental stages (Pedro et al., 2005). In sheep morula, ethylene glycol permeates faster than propylene glycol, dimethyl sulfoxide (DMSO) and glycerol (Songsasen et al., 1995). DMSO, on the other hand, shows moderate permeability on embryos at different preimplantation stages, with little difference. Being the most permeating cryoprotectants on 1-cell embryos and 2-cell embryos, propylene glycol permeates better than ethylene glycol. In general, there is a trend of increased permeability of the membrane towards various cryoprotectants when embryos develop (Mazur & Schneider, 1986; Pedro et al., 2005).

The findings indicate a dynamic change in permeability of cell membrane to different cryoprotectants during development. This permeability change does not correlate with the molecular size of the cryoprotectants. In addition, the dynamic changes in cryoprotectant permeability do not seem to be caused by the increase in the total surface area of the embryos. The mouse 8-cell embryos undergo compaction at late day 4, thus decreasing the total surface area drastically, but it is best penetrated at least by ethylene glycol, compared with 1-, 2- and pre-compacted 8-cell embryos (Pedro et al., 2005), which have a higher surface area to volume ratios. Altogether, these findings support the notion that permeability is a dynamic physiological change related to the cellular differentiation state, not a simple passive mechanism dictated by the physical size and surface area. Understanding the changes of permeability of embryos to cryoprotectants at the molecular level may help further develop the use of cryopreservation technologies on mammalian embryos and, more importantly, on other organisms that cannot be cryopreserved yet.

Cryoprotectants		Permeability to different mouse embryo			
Common name	Molecular property	1-cell	2-cell	Pre-compact morula (8-cell)	Compact morula (8-cell)
Acetamide	Amide, MW=59	Moderate	Moderate	High	High
Ethylene glycol	Polyhydric alcohol, MW=62.1	Moderate	Moderate	High	High
Propylene glycol	Polyhydric alcohol, MW=76.1	High	High	High	High
DMSO	Organosulfur, MW=78.1	High	High	High	High
Glycerol	Polyol, MW=92	Impermeable	Impermeable	Moderate	High

Table 1. Permeability of various common cryoprotectants to mouse preimplantation embryos (Information derived from Pedro et al., 2005)

### 2.3 Cryoprotectant toxicity to mammalian embryos

The higher the concentration of cryoprotecting agent is in a solution, the lower is the likelihood water crystals would be formed in the solution in a rapid-cooling process. However, most cryoprotecting molecules are toxic to embryos with toxicity positively correlating to their concentrations and the exposure time. When choosing the appropriate cryoprotectants, toxicity must be considered. Among five common permeating cryoprotecting agents to be tested, toxicity was determined to be dimethylformamide > erythritol > DMSO > glycerol and ethylene glycol on mouse morulae (Kasai et al., 1981). By electron probe microanalysis, Pogorelov et al. (2006 & 2007a) detected a dramatic decrease in intracellular potassium and sodium content in two-cell embryos treated with procedures mimicking vitrification in ethylene glycol, demonstrating a potential stress exerted on the

embryos. When the mouse morulae were stored in 1.5M ethylene glycol or glycerol for 6 hours, the majority (>75%) of the embryos retained the capacity to develop into expanded blastocysts (Kasai et al., 1981). To minimize the toxic effect of the cryoprotecting solution to the embryos while retaining the cryoprotecting function, a mixture of two or more cryoprotecting agents could be used to decrease the relative concentration of each chemical. Macromolecules such as polyethylene glycol, ficoll and polyvinylpyrrolidone, which increase the viscosity of a solution, thus slowing down water molecules associating to form ice crystals when cooling, can also lower the concentration of cryoprotecting agents to be used in vitrification.

## **2.4 Osmotic flows in cryopreserving mammalian embryos**

### **2.4.1 Slow-cooling**

In a general slow-cooling procedure, embryos are immersed into permeating cryoprotectants. Intracellular water leaves the cells by osmosis and re-enters the cells together with the permeating cryoprotectants by diffusion. A temporal osmotic equilibrium state is acquired at the end. A 1-2M permeating cryoprotecting agent(s) is often used in slow-cooling. To cryopreserve the embryos, embryos and the surrounding freezing medium are loaded into a plastic straw and subjected to cooling to a temperature slightly lower than the freezing point, i.e. at about  $-7^{\circ}\text{C}$ . Controlled ice nucleation is initiated by touching the straw with a cooler surface (e.g., a pair of forceps) to initiate the growth of ice inside the straw. The embryos themselves remain unfrozen but supercooled. The removal of water from the solution by the growing ice crystals increases the solute concentration of the extracellular medium. By osmosis, the intercellular water leaves the cells, resulting in an increase of cryoprotectant concentration in the cells. The subsequent slow cooling further dehydrates the embryos and concentrates the cryoprotectant in the cells to promote intracellular solidification, without intracellular ice formation, at a sufficiently low temperature. If the cooling is too fast, it leads to intracellular ice formation because the intracellular solute has not yet achieved a sufficiently high concentration. Too slow a cooling rate causes cells' death due to the prolonged exposure to hypertonic conditions. The cooling rate must be carefully controlled for each embryonic stage of each species because the permeability of cell membranes, and thus the hydrodynamics, of different samples, can be different.

### **2.4.2 Vitrification**

In cryopreservation by vitrification (or rapid-cooling), equilibration of cryoprotectants in the embryos and the cryoprotecting medium are not required. Embryos are first permeated by cryoprotecting agents at a low concentration and then immersed in a moderately high concentration (4M or above) of the same cryoprotecting agent, sometimes together with non-permeating cryoprotectants such as 0.5M sucrose. In the presence of the non-permeating cryoprotectants, the embryos shrink osmotically, thus further increasing concentration of intracellular cryoprotectants. The high concentration of cryoprotecting agents in the medium prevents efflux of intracellular cryoprotecting agents by diffusion (Figure 4). The embryos are then loaded into a container and are rapidly cooled to solidify the embryos without the formation of ice crystals (Rall, 1987). Mathematical modelings such as the relativistic permeability approach is able to simulate the osmotic curve in these

processes to facilitate the optimization of vitrification protocols in future (Katkov and Pogorelov, 2007).

## 2.5 The success of cryopreservation on mammalian embryos

The first mammalian embryo that survived cryopreservation was the mouse embryo 40 years ago by slow-cooling (Whittingham et al., 1972). More than 50% of preimplantation embryos survived after thawing and about 40% of the surviving embryos developed to full-term after being transferred to foster females. A similar protocol was applied successfully on cow embryos (Wilmut & Rowson, 1973), sheep embryos (Willadsen, 1977) and many other domestic mammals (Saragusty & Arav, 2011), suggesting that slow cooling is basically applicable to other mammalian embryos, provided the cooling rate can be optimized and well controlled. By using 1.5M DMSO as a cryoprotectant, sheep morulae and blastocysts were cooled at a rate of 0.1°C per minute. A survival rate of 80% can be achieved. With a similar protocol developed from mouse experiments, the first pregnancy after transfer of a cryopreserved human 8-cell embryo was recorded in 1983 (Trounson & Mohr, 1983). The pregnancy terminated at 24-weeks due to premature rupture of the membrane and *Streptomyces agalactiae* infection (Trounson & Mohr, 1983). A year later, Zeilmaker et al. (1984) described the first live birth after the transfer of cryopreserved human embryos. More reports of live births of cryopreserved human embryos were reported in the following year (Cohen et al., 1985; Downing et al., 1985) and in the years after that.

With the extensive characterization of embryo-cryoprotectant interactions, the feasibility of embryo cryopreservation by vitrification was demonstrated by Rall and Fahy (1985). The next challenges were to further lower the concentration of the cryoprotecting agent to be used and to increase the cooling rate. Increasing the cooling rate not only guarantees the absence of ice formation but also allows a further decrease in the amount of cryoprotecting agents being used, thus minimizing the potential toxic effects on the embryos. It can be illustrated by a recent report describing the use of a highly conductive micro-capillary to increase the cooling rate up to about 4,000°C per second. The cryoprotectant propylene glycol concentration can be reduced to 1.5M, compared to the normally used 4M or above (Lee et al., 2010). Over the past decade, a variety of holding devices have been developed to allow fast transmission of heat (thus a high cooling rate) from the sample to the coolants (reviewed in detail in Tsang and Chow, 2010). Some researchers have made use of containers with thinner walls, such as pulled-straw (Vajta et al., 1998). Others have made use of an open property of the devices to hold the sample on a surface to allow direct heat transfer between the samples and the coolant. These include the electronic microscopic metal grid (Martino et al., 1996), cryoloop (Lane et al., 1999), nylon mesh (Matsumoto et al., 2001), hemi-straw (Vanderzwalmen et al., 2003), cryotop (Kuwayama et al., 2005), vitrification spatula (Tsang & Chow, 2009) and plastic blade (Sugiyama et al., 2010). Using most of these open-systems, cryo-survival rates of above 80% are usually obtained. The remaining challenge is to select the right tool by considering the microbial surveillance requirement (a closed-storage system versus an open-storage system), the convenience factor and economic considerations in a routine facility operation.

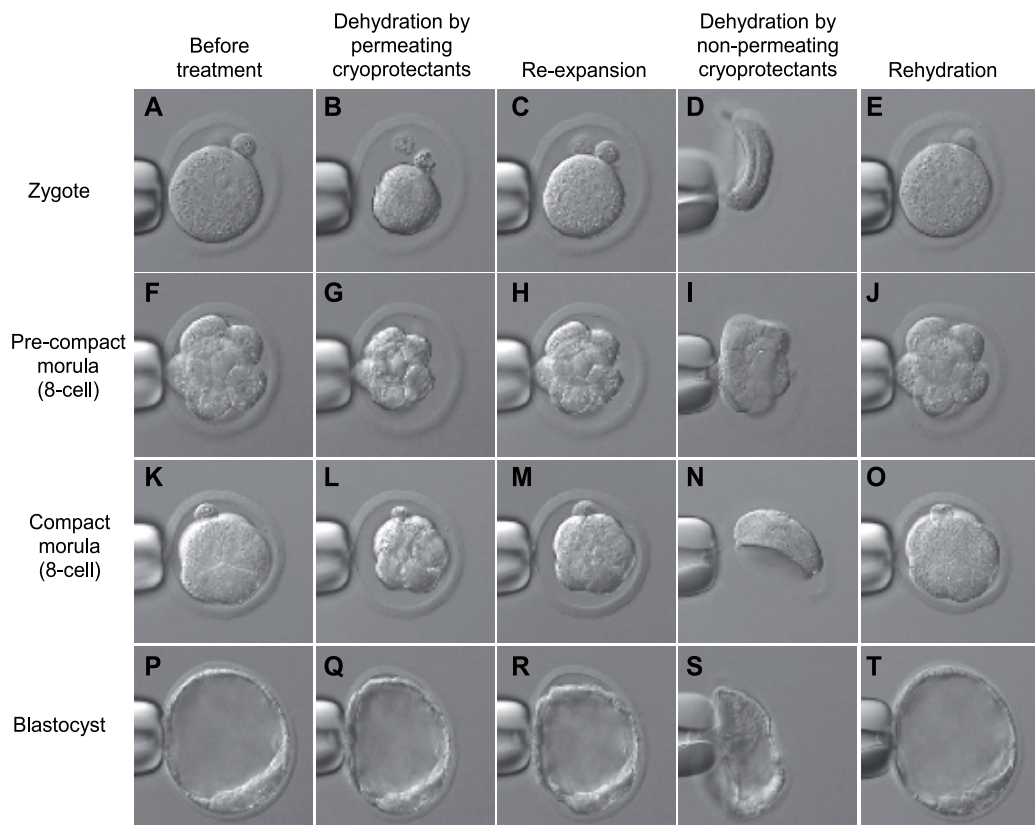

Fig. 4. Morphological changes of mammalian (mouse) preimplantation embryos in response to cryoprotectant treatments (for vitrification) and rehydration. Panel A-E: zygote (1-cell); panel F-J, pre-compact morula (8-cell); panel K-O, compact morula (8-cell); panel P-T, expanded blastocyst. Individual embryos were held by a glass micropipette by a slight suction under physiological isotonic medium (A, F, K and P). Vitrification solutions containing low concentration of permeating cryoprotectants and high concentration of permeating cryoprotectants plus non-permeating cryoprotectants were applied to the surroundings of the embryos, sequentially. About 30 seconds after the application of solution containing low concentration of permeating cryoprotectants, the embryos osmotically shrunk to minimal volumes (panel B, G, L and Q). The embryos (except the blastocyst) later re-expanded to a size closer to the original volumes, after an additional 30 seconds, when cryoprotectants and water re-entered the cells passively (panel C, H, M and R). After addition of the final vitrification solution containing high concentration of permeating cryoprotectants and non-permeating cryoprotectants, the embryos were further dehydrated by osmosis and shrunk without re-expansion. (panel D, I, N and S) High concentration of intracellular permeating cryoprotectants was achieved. Rapid cooling is normally done at this stage to vitrify the embryos but such cooling was not done in this demonstration. Step-wise rehydration of the embryos was done after dehydration to imitate the recovery steps after thawing the embryos from vitrification. After rehydration, the embryos re-expanded to their original size and regained normal morphologies (E, J, O and T).



Vitrification is now well accepted as a reliable means for cryopreserving mammalian embryos because of its simplicity; it does not require a controllable cooler. One factor responsible for the acceptance of this technology for cryopreservation of mammalian embryos has been the intensive studies on the interaction between different cryoprotectants and embryos, i.e. permeability and toxicity, at different developmental stages. Luckily, the most permeating cryoprotectants are not very toxic to the embryos. It allows the use of the cryoprotectants at a high concentration, yet below the lethal dose, to promote vitrification in response to a convenient cooling rate in most laboratories.

### 3. Cryopreservation of larvae of nematodes and platyhelminthes

#### 3.1 Development of the nematode

Nematoda belong to the ecdysozoa, sharing the same clade with arthropoda. The members range from free living species to parasitic species in plants and animals. The life cycle of the nematode is generally divided into five morphological stages. Each successive larval stage is preceded by a molting process to remove the collagenous cuticle from the former larval stage. At hatching, the first-stage larva (Figure 3 A) consisting of 558 cells is under the protection by a cuticular layer. The animal grows in size after each hatching. In adulthood, a reproductive hermaphrodite is about 1mm long, 0.06mm in diameter, containing about 1,000 somatic cells. In comparison, a first-stage larva is about 0.37mm in length and 0.025mm in diameter.

Under favorable conditions, the development of the animal continues through the first- to the fourth-larval stage and finally to the reproductive adults. In many parasitic species such as the entomopathogenic species, the third-stage larvae are juveniles that are infective to their hosts. Under unfavorable conditions, i.e. outside the host body, a second-stage larva develops into the third-stage infective juvenile but retains the cuticle from the last larval stage to form a sheath. The entire animal is enclosed in the sheath until a suitable host is infected.

#### 3.2 Cryopreservation of nematode without cryoprotectant additive

The simplest method for nematode cryopreservation was reported on ruminant nematodes. Infective juveniles were cooled directly in liquid nitrogen vapor after being unsheathed by sodium hypochlorite, and suspended in physiological saline (Campbell and Thomson, 1973; Van Wyk et al., 1977). For example, infective juveniles of sheep nematodes (*Haemonchus contortus*, *Ostertagia circumcincta*, *Trichostrongylus axei*, *Trichostrongylus colubriformis*, *Nematodirus spathiger* and *Oesophagostomum columbianum*) and the bovine nematodes (*Haemonchus placei*, *Ostertagia ostertagi*, *Nematodirus helvetianus*, *Oesophagostomum radiatum*, *Cooperia pectinata* and *Cooperia punctata*) survived these simple cryopreservation procedures.

James (1985) suggested that the presence of natural cryoprotectants plays a role in the cryo-survival of domestic animal parasitic nematodes. Bai et al. (2004) demonstrated in *Steinernema carpocapsae* and *Heterorhabditis bacteriophora* that the cryo-survival rates of infective juveniles are positively correlated with worm concentration during the cryoprotectant glycerol incubation step. The survival rates ranged from about 20% to 100%, which was proportional to worm concentration of 120-12,000 per ml (Bai et al., 2004). Infective juveniles indeed produce cryoprotecting molecules such as trehalose and glycerol,

in response to thermal and other environmental stresses (Jagdale & Grew, 2003; Qiu & Bedding, 2002). The trehalose content in *Steinernema carpocapsae* increases from 4% to 8% after being incubated in 22% glycerol for 18 hours, before the animals are further processed for cryopreservation (Popiel & Vasquez, 1991). Production of natural cryoprotectants by the animal itself could, therefore, be the key to good animal survival in this cryopreservation procedure. Exploring an efficient way to induce the production of the natural cryoprotectants can improve cryo-survival. Identifying the molecular pathway responsible for cryoprotectant production may help make cryopreservation of these species simpler.

### 3.3 Slow freezing with DMSO and glycerol

Storage of live nematodes in liquid nitrogen was first demonstrated by Hwang (1970) who reported survival of animals in the genera *Aphelenchoides*, *Panagrellus*, *Turbatrix* and *Caenorhabditis*, after slow-cooling in heat-sealed glass ampoules, using DMSO as cryoprotectants. Later, glycerol was applied to slow cooling of *Caenorhabditis elegans* at the first-larval stage (Brenner, 1974) and since then this cryopreservation procedure has been routinely used for freezing this model organism in laboratories in the past 40 years. Up to 100% of the first-stage larvae survival can be achieved.

On the other hand, a slow-cooling method using DMSO as a cryoprotectant was used for cryopreserving another *Caenorhabditis* species popular in basic scientific research, i.e. *Caenorhabditis briggsae* (Haight et al., 1975). The worms were simply suspended in cooled 5% DMSO for 10 minutes and then slowly cooled at a rate of 0.2°C per minute to -100°C before storage in liquid nitrogen. About 75% of the animals at the second-larval stage and the third-larval stage, 50% of the fourth-stage larvae and 3% of the adult animals survived the freezing/thawing cycle. In contrast to *Caenorhabditis elegans*, no animals at the first-larval stage survived the cryopreservation (Haight et al., 1975). Obviously, traits favoring the cryopreservation procedures are present in different larval stages in both species.

The dog parasitic nematode *Strongyloides stercoralis* can be cryopreserved by slow cooling after incubation for up to 60 minutes in a solution containing 10% DMSO. When thawed, third-stage larvae retain infectivity to dogs and the recovered first-stage larvae develop to the third-larval stage and regain infectivity (Nolan et al., 1988). The cryopreserved sheep nematodes *Haemonchus contortus*, *Trichostrongylus colubriformis* and *Ostertagia circumcincta*, at the first-larval stage, retained their infectivity as well as unfrozen worms, when cooled slowly in 10% DMSO to -80°C before being transferred to liquid nitrogen for storage (Gill and Redwin, 1995).

### 3.4 Vitrification by an ethylene glycol two-step procedure

Before being used in mouse and fly embryo vitrification, ethylene glycol had been used for vitrifying the human platyhelminth *Schistosoma mansoni* and the farm animal nematode *Onchocerca microfilariae* in a similar two-stage procedure. *Schistosoma mansoni* were pre-incubated in 10% ethylene glycol at 37°C for 10 minutes, then cooled at 0°C for 5 minutes and finally incubated in 35% ethylene glycol for 10 minutes at 0°C. Before being rapidly cooled in liquid nitrogen, the worms were spread on a glass sliver (prepared from microscopic coverslips) which acted as an open carrier. About half of the thawed worms survived and remained infective in mice with an efficiency equivalent to half that of

unfrozen worms (James, 1981). On the other hand, 70% of the *Onchocerca microfilariae* were viable and remained infective after vitrification and thawing (Ham et al., 1981).

A similar vitrification methodology was also applied to the plant parasitic nematode *Meloidogyne Graminicola*, a rice root-knot nematode (Bridge & Ham 1985). The second-stage larvae were pre-incubated in 10% ethylene glycol at 37°C for 15 minutes and then incubated in 40% ethylene glycol for 30-45 minutes. The worms were then rapidly cooled in liquid nitrogen in the same manner as James (1981) on *Schistosoma mansoni*. This two-stage vitrification procedure on plant nematodes was later modified by Triantaphyllou & McCabe (1989) who replaced the glass coverslip slivers with a small strip of chromatography paper as a carrier device. A survival rate of up to 90% was obtained. The author reported that the modified two-step method produced satisfactory results on other plant parasitic nematodes also, such as some *Meloidogyne* and *Heterodera* species (Triantaphyllou & McCabe, 1989).

### 3.5 Vitrification by a glycerol/methanol two-step procedure

An entirely different treatment methodology was developed primarily for vitrifying the entomopathogenic nematodes in the genera *Steinernema* and *Heterorhabditis*, which are effective as a biological control agent for insect pests in agriculture (Popiel & Vasquez, 1991). *Steinernema carpocapsae* were pre-incubated in 22% glycerol at room temperature for 24 hours and then in ice cold 70% methanol for 10 minutes. After removal of the majority of methanol by centrifugation, concentrated worms in methanol (i.e. 20µl) were spread on a small strip of filter paper before plunging into liquid nitrogen for rapid cooling. Up to 95% post-thaw survival rate could be obtained. On the other hand, a post-thaw survival rate of about 55% was obtained on *Heterorhabditis bacteriophora* when the optimal 14% glycerol was used (Popiel & Vasquez, 1991).

Curran et al. (1992) further optimized the protocol by replacing the centrifugation with a filtration step to remove glycerol prior to the methanol incubation. The optimal conditions for glycerol incubation for a number of entomopathogenic nematodes were also determined. Optimal glycerol pre-incubation conditions were determined to be 18% glycerol for 24 hours for *Steinernema carpocapsae*, 17% glycerol for 72 hours for *Heterorhabditis bacteriophora* and 13.8% glycerol for 72 hours for *Steinernema feltiae* and *Steinernema glaseri* (Curran et al., 1992). Other than that, 167 entomopathogenic nematodes were found to be able to survive the cryopreservation treatments, proving the feasibility of cryobanking of these worms. The mean survival rate of the *Steinernema* species is 58% (ranging from 25% to 97%) and that of *Heterorhabditis* species is 51% (ranging from 25% to 87%).

Based on the modification by Curran et al. (1992), Nugent et al. (1996) optimized cryopreservation on seven isolates of *Heterorhabditis*. Up to 8 days of pre-incubation in 11% or 15% glycerol is optimal for cryopreserving a couple of isolates. Nugent (1996) also found that glycerol can be replaced by DMSO in the pre-incubation step. For example, incubation of isolate HI82 in 8% DMSO for 3 days yielded a survival rate of about 80%, similar to those pre-incubated in 15% DMSO.

To the best of our knowledge, unlike mammals, there have been no studies of interactions between nematodes and cryoprotectants. Conversely, different protocols have been developed independently by different groups for specific worm species. Whether the different protocols are indeed applicable to other groups of nematodes or not requires

further investigation. Nonetheless, we can interpret from the protocols that nematodes are generally resistant to cryoprotectant toxicity because most protocols involve a relatively long incubation time in cryoprotecting solutions. Surprisingly, most of the protocols do not involve removal of the cuticle, which is well known for its poor permeability, though successful cryoprotection requires the presence of enough intracellular concentration of cryoprotectant. It is possible that the cryoprotectants themselves can permeabilize the cuticle and then permeate into the cells beneath. Or the cryoprotectant enters the worm via the oral opening and the gut, into the rest of the body. Equally possible is that the "cryoprotectants" did not act as a cryoprotectant *per se* but acted as inducers to trigger the production of natural cryoprotectant in the worm. Therefore, thorough permeation of the chemicals was not required.

## 4. Cryopreservation of insect embryos

### 4.1 Development of insect embryos

*Insecta* is a class with the greatest interest among the *Arthropoda*. Pathogenic vectors associating mosquitoes, flies and bugs are of interest in medical and healthcare related research. Honeybee, silk moth, beetle and other moths are of economic interest to the beekeeping industry, silk industry and pest control in agriculture, respectively. The fruit fly *Drosophila melanogaster*, a species of the order *Diptera*, is chosen as an insect model in genetic studies because of its ease of keeping, handling and observing. It has a short life cycle and is fertile through out the year. A complete life cycle involves four distinct stages of development, which takes 8.5 days for a *Drosophila* egg to reach adulthood at 25°C.

A *Drosophila melanogaster* egg is about 0.18mm in width and 0.5mm in length, occupying a volume of about 9nl. The laid egg is a single cell with about 6,000 nuclei which later migrate to the plasma membrane to form a syncytial blastoderm at around 2 hours. Cell membranes form between the nuclei at around 2.5 hours. As gastrulation occurs, a ventral furrow and a cephalic furrow form. The midgut invaginates followed by a germ band extension (3-7 hours), stomodeal invagination (5-7 hours), germ band shortening, foregut and hindgut deeply invaginate (9-10 hours). The ectoderm closes dorsally and the head involutes at about 10-13 hours (Figure 3B). At around 13 hours, organogenesis has already begun in the 50,000-cell embryos. Organogenesis is completed and the gut regions are joined between 15 and 22 hours (i.e. at hatching) (Markow et al., 2009; Weigmann et al., 2003; Grumblin & Strelets, 2006). The hatched larva experiences three instar larval phases, before the skin of the third-instar larva hardens and encapsulates the animal to form a puparium. It takes four days for the third larva to transform into an adult by metamorphosis. At the end of metamorphosis, the adult of about 2.5mm length emerges from the puparium.

### 4.2 Permeabilization of insect embryos to cryoprotectants

The outermost layer of the eggshell of an insect embryo is a porous proteinacious chorion with a thickness ranging from 300-500nm in *Drosophila* to more than 40µm in saturniid moth (Magaritis et al., 1980; Fehrenbach, 1995). Underneath are: (1) the innermost crystalline chorion layer of about 40nm in *Drosophila* (Papassideri & Margaritis, 1996), (2) the waterproofing wax layer (Beament, 1946; Slifer, 1948) and (3) the vitelline layer (Papassideri et al., 1991). The wax layer is only 5nm in thickness in *Drosophila* and is intercalating with

the outer crystalline chorion layer and the inner vitelline layer (Papassideri et al., 1991). The wax is mainly composed of n-alkanes and methyl-branched alkanes (Nelson & Leopold, 2003), making the eggshell impermeable even to water, thus protecting the embryos from desiccation. Extracting the dechorionated eggs with a wax removing solvent makes the vitelline membrane permeable to water, cytological stains and antibiotics (Schreuders et al., 1996), (Limbourg & Zalokar, 1973). It supports the notion that the wax component in the vitelline layer is the major factor blocking the cryoprotecting molecule from permeating into the embryos.

To facilitate permeation of cryoprotectants into insect embryos for further cryopreservation protocol development, attempts were made to permeabilize the eggshell but retain the viability of the embryos. Removal of the chorion can be done by exposing the eggs to about 2.5% sodium hypochlorite, without compromising the survival of the embryos (Lynch et al., 1989). Permeabilizing the inner layer of the eggshell with low injury can be done by a 2-step method. Dechorionated eggs of 12-13 hour embryos were rinsed with isopropanol and hexane. The embryos in permeabilized eggshell experienced minimal injury with a survival rate of 75% to 90% in culture medium (Lynch et al., 1989). This procedure resulted in 80%-95% of the treated eggs being permeabilized to water, ethylene glycol, propylene glycol, glycerol and DMSO. Mazur et al. (1992b) further optimized the two-step method to allow permeation of common cryoprotectants such as ethylene glycol and glycerol. The best result was obtained by exposing the dechorionated 12-14 hour embryos to 0.3%-0.4% 1-butanol in n-heptane for 90 seconds. At least 90% permeabilization and 80% survival can be obtained. Older embryos between 14-16 hours are much less sensitive to the above procedures, which are lethal to 3 hour embryos. Using procedures similar to Mazur (1992b), with decreased concentration of sodium hypochlorite in dechorionation and replacing isopropanol with air drying, all mosquito (*Anopheles gambiae*) embryos at 15-19 hours can be permeabilized in ethylene glycol with an acceptable survival rate of 30% (Valencia et al., 1996). On the other hand, heptane treatment seemed to be detrimental to the greater wax moth (*Galleria mellonella*) embryos. Replacing the heptane treatment with incubation in 1.25% sodium hypochlorite with 0.08% Tween-80 for 2 minutes permeabilized the moth embryos with 68% survival (Cosi et al., 2010). Determination of the optimal permeabilization procedures and the optimal embryonic stage to be permeabilized in different insecta species has opened the door for efficient cryopreservation of this largest class of animals on land.

### 4.3 Chilling sensitivity of insect embryos

*Drosophila* embryos are highly sensitive to chilling. When 15 hour eggs were incubated at -15°C, 50% of the embryos died within an hour even in the absence of ice formation. When younger embryos at 3 hours and 6 hours were cooled to the same temperature, the chilling injury increased dramatically (Mazur et al., 1992c). All 12 hour embryos died at -25°C when cooled at 1°C per minute. A similar phenomenon was found in case of honey bee (*Apis mellifera*) embryos (Collins & Mazur, 2006). The slow cooling approach that requires time for efflux of intracellular water osmotically to avoid intracellular ice formation is, therefore, theoretically impractical for handling insect embryo cryoprotection. It was estimated that cooling the embryos faster than 300°C per second can circumvent the chilling injury by shortening the time the embryo stays at such a low temperature. However, lethal

intracellular ice forms at such a cooling rate when using the standard concentration of cryoprotectants (Mazur et al., 1992c). Vitrification is, therefore, the only possible way to cryopreserve insect embryos.

#### 4.4 The success of insect embryo vitrification

Adopting and modifying the protocol for vitrifying mouse embryos with ethylene glycol (Rall & Fathy, 1985), Steponkus et al. (1990) first demonstrated successful vitrification of 13-14 hour *Drosophila* embryos. Instead of permeabilizing the vitelline layer with the currently developed method using an alkane, the eggs were "permeabilized" with a medium containing 2.125M ethylene glycol for 20 minutes. The intracellular concentration of ethylene glycol was further increased by dehydrating the embryos in 8.5M ethylene at 0°C for 8 minutes before plunging the embryos into nitrogen slush (-204°C), using a copper electronic microscopic grid as an open carrier (to achieve a cooling rate of about 400°C per second). After thawing, 18% of the eggs hatched and 3% developed into fertile adults. On the contrary, there were no embryos surviving at a lower cooling rate of 15°C per second when using a polypropylene straw as a carrier. The surrounding cryoprotecting solution vitrified *per se* since no crystals were detected by differential scanning calorimetry. The high lethality is probably due to the suboptimal permeabilization of the vitelline layer by ethylene glycol, leading to a lower concentration of cryoprotectants in the inner part of the multicellular/highly differentiated insect embryos. This may result in crystallization of water in the area with a lower concentration of cryoprotectant which would require a higher cooling rate to induce vitrification. A higher cooling rate was achieved by using a metal grid allowing vitrification to occur at such low concentrations of cryoprotectants, thus partially circumventing this potential permeating defect. Using a similar protocol, other *Dipteral* species such as blowfly (*Lucilia cuprina*, a parasite in sheep) (Leopold & Atkinson, 1999 20), midge (*Culicoides sonorensis*) (Nunamaker & Lockwood, 2001) and screw-worm (Leopold et al., 2001) were reported to be cryopreserved.

On the other hand, Mazur et al. (1992a) made use of the accumulated experience of wax removal by butanol-heptane based procedures to permeabilize the vitelline membrane prior to vitrification. In the optimized procedure, dechorionated *Drosophila* embryos were first permeabilized in 0.3% 1-butanol in n-heptane for 90 seconds. The embryos were then pre-incubated in 2M ethylene glycol for 30 minutes and then 8.5M ethylene glycol solution containing 10% polyvinylpyrrolidone for 5 minutes at 5°C before rapid cooling, using a filter membrane as an open carrier. The developmental stage of the embryos was also found to be critical for cryo-survival determination. Vitrifying precisely staged 14.5 hour embryos using the above mentioned method resulted in 60% of the cryopreserved embryos hatching and more than 40% of the hatched larvae developed into fertile adults (Mazur et al., 1992a).

The development of cryopreservation on *Drosophila* embryos suggests that permeabilization of the sample to cryoprotectant is the key to success even though the embryos are structurally complex. In nematode larvae, which are also susceptible to being cryopreserved, the organogenesis is even more advanced. This indicates that the body complexity brought about by organogenesis is not associated with the susceptibility of an embryo/larva to be cryopreserved, at least by vitrification. On the other hand, chilling injury can be circumvented by vitrification practically.

## 5. Cryopreservation of teleost embryos

### 5.1 Development of teleost embryos

The zygote of zebrafish (*Brachydanio rerio*) is about 0.7 mm in diameter when fertilization occurs. A few minutes later, the chorion swells to increase the diameter to about 1.2 mm, without much alteration in thickness, generating a significant vitelline space. The cytoplasm segregates to form the animal pole and the vegetal yolk with an approximate total volume of 128nl, not including the vitelline space and the chorion (Leung et al., 1998). The first cell cleavage occurs in the animal pole at about 45 minutes after fertilization. The blastomere gets divided five more times synchronously, each at about 15 minutes interval, producing a blastoderm with 64 cells in 2 hours. The daughter cells increase in number with a decrease in cell size. The blastomeres arrange themselves in a single cell layer before the fifth cleavage. Afterwards, newly formed daughter cells overlap with each other in the blastoderm. The multi-cell layered blastoderm spread over the yolk, reaching 30% epiboly at 4.7 hours and 50% epiboly at 5.25 hours (Figure 3C). At the gastrula period, epiboly continues at 5.3 hours. Two germ layers, i.e. epiblast and hypoblast, are formed by morphogenetic movement of involution, convergence and extension. Epiboly reaches 90% at 9 hours. At the end of this period, the tail bud and neural plate starts to form. The volume of the epiboly remains constant from 40% epiboly to 100% epiboly. Entering the segmentation period at 10 hours, segmentation processes such as formation of neuromeres, somites and the pharyngeal arch primordia occur. The embryo volume increases to 0.23 mm<sup>3</sup> at the six-somite stage at 12 hours when organogenesis starts (Hagedorn et al., 1997c). At the end of the 14 hour-period, the yolk largely reduces and tail movement can be seen. Pigment can be identified after 36 hours. At the third day, the primary organogenesis completes. Cartilage in the head and pectoral fin develops while hatching occurs anytime in the third day (Kimmel et al., 1995).

### 5.2 Complexity of teleost embryos

Fish embryos are composed of several components with distinct physical properties. They include the highly dynamic cellular part on the animal pole which contributes entirely to the future animal body, the yolk surrounded by the yolk syncytial layer occupying the majority of the early stage embryo and the chorion as the outermost mechanical protective shield. From 40-100% epiboly, the blastoderm and the yolk occupy 18% and 82% of the dechorionated embryo, respectively, in zebrafish (*Brachydanio rerio*). At the six-somite stage, the volume of the blastoderm increases to about 40%, leaving the yolk occupying 60% of the embryo (Hagedorn et al., 1997c). Between the chorion and the embryo is the perivitelline space filled with liquid with a chemical composition virtually identical to the surrounding medium (Rawson et al., 2000). The complexity of the teleost embryos is further increased by the unbalanced partial density of water in different compartments. At the six-somite stage, the blastoderm occupies about 40% of the dechorionated embryos but water constitutes 82% of its volume. Conversely, the yolk occupies about 60% of the volume of the dechorionated embryos but only 42% of this is constituted by water (Hagedorn et al., 1997b). It was estimated that the osmotically inactive volume in the one-somite stage and six-somite stage embryos are 72.9% and 82.6%, respectively (Zhang & Rawson, 1998).

### 5.3 Permeability of teleost embryos

The low permeability of the chorion and the perivitelline is evident from retarded permeation of radio-labeled DMSO from the external medium into the embryos by several folds (Harvey et al., 1983). Even after removal of the outermost barrier, the embryos were poorly permeated by cryoprotectants. By chemical shift selective magnetic resonance microscopy and magnetic resonance spectroscopy, kinetics of permeation of cryoprotectants methanol, DMSO and propylene were measured. While methanol can permeate the entire six-somite zebrafish (*Brachydanio rerio*) embryos in 15 minutes, DMSO and propylene are relatively poor in permeating into the embryos when applied to the medium (Hagedorn et al., 1996). Similar findings were obtained by osmometric measurements of volume changes in the embryos tested (Hagedorn et al., 1997c). Also, magnetic resonance imaging on the distribution of cryoprotectants, delivered to the external medium or injected into the yolk, in the three-somite stage *Brachydanio rerio* embryo revealed that the yolk is far less permeable than the blastoderm and the yolk syncytial layer is the major barrier to the cryoprotectants (Hagedorn et al., 1996; Hagedorn et al., 1997a).

To artificially promote permeation of cryoprotectants into fish embryos, ultrasound of 175V was used to increase the permeability by methanol to *Danio rerio* 50% epiboly (Wang et al., 2008). A high-intensity femtosecond laser was also used to introduce transient pores on blastomeres and the blastoderm-yolk boundary. Successful delivery of large molecules such as fluorescein isothiocyanate, streptavidin-conjugated quantum dots and DNA plasmid was detected on pec-fin stage (Kohli et al., 2007). Whether the physically induced permeation method can help cryopreservation of the whole teleost embryos requires experimental verification.

### 5.4 Chilling sensitivity of teleost embryos

Medaka (*Oryzias latipes*) embryos at early cleavage stage, i.e. 2-4-cell stage, are very sensitive to cooling at 0°C for 40 minutes. Only 38% of the embryos survived the chilling treatment. However, the same chilling treatment did not affect the survival of embryos in early gastrula stage (Valdez et al., 2005). Similarly, zebrafish (*Brachydanio rerio*) at cleavage stage are more sensitive to chilling than embryos at epiboly and at three-somite stage (Hagedorn et al., 1997c). This indicates that embryos at later developmental stages are more resistant to chilling. A similar phenomenon was found on other teleost species such as red sea bream, olive flounder and multicolorfin rainbowfish. In the same study, it was found that cleavage stage embryos responded to chilling by obstructing mitotic division and early gastrula stage embryos responded by delayed development at epiboly (Sasaki et al., 1998).

### 5.5 Cryoprotectant toxicity on teleost embryos

Incubation of the three-somite stage zebrafish (*Brachydanio rerio*) embryos in 1.5M DMSO and methanol for 30 minutes at room temperature did not adversely affect their survival. While propylene glycol is moderately toxic to the embryos, similar treatment with ethylene glycol or glycerol is lethal to all treated embryos. Of the cryoprotecting agents tested, ethylene glycol solution specifically led to the blastoderm being dissociated from the yolk (Hagedorn et al., 1997c). A similar phenomenon was observed on 14 to 20-somite stage embryos of *Danio rerio* (Higaki et al., 2010b). Treating the embryos with glycerol at a



concentration of 2M for 30 minutes did not yield any viable cells in the embryos. The rest of the cryoprotectants tested (including methanol, ethylene glycol, DMSO, propylene glycol and 1,3-butylene glycol) gave a survival rate of between 90 to 100%. Treating the embryos with cryoprotectants at a higher concentration revealed that ethylene glycol is the next most toxic cryoprotectant, after glycerol; it kills all cells in the embryos at a concentration of 3M. In comparison, methanol and DMSO are moderately toxic. Propylene glycol and 1,3-butylene glycol are mildly toxic, killing only 58-78% of cells even at a concentration of 5M (Higaki et al., 2010b).

### 5.6 Attempts in vitrifying teleost embryos

So far, there have been no successful examples of live fish recovery after cryopreservation. The difficulty in controlling the dynamics of cryoprotecting agents and water in the highly structurally complex embryos may be the cause. However, studies have been conducted to assess the degree of protection provided by the cryoprotectant in vitrification. In a study, five-somite stages of turbot and zebrafish embryos were treated for 5 minutes with incremental concentrations of DMSO and then for a total time of 4 minutes in mixtures containing 5M DMSO, 2M methanol and 1M ethylene glycol, before being loaded into plastic straws and plunged into liquid nitrogen for vitrification. Although 50% of the overall glucose-6-phosphate dehydrogenase activity was retained, no embryo hatched after thawing (Robles et al., 2004).

The yolk and the surrounding syncytial layer were suggested to be a major reservoir of osmotically inactive water and a barrier to permeation of cryoprotectant to the blastoderm. After vitrifying yolk-removed zebrafish (*Danio rerio*) embryos at 14 to 20-somite stage in 20% ethylene glycol, 20% DMSO and 0.5M sucrose, no living embryos were obtained, but 87% of the cells survived after vitrification and up to 90% of the primordial germ cells were viable (Higaki et al., 2010a). Removal of yolk is deleterious to the development of the embryos. Eliminating the solute and water barrier by yolk removal is not the ultimate solution for cryopreserving fish embryos unless an artificial replacement of yolk is made feasible.

### 5.7 Alternatives for whole embryo cryopreservation

Due to the lack of progress in development of cryopreservation of fish embryos, isolated somatic cells are being explored as a means to preserve diploid genetic materials. The blastomere becomes one of the attractive candidates because of its abundance in embryos and its pluripotent property in the chimeric animals generated by blastomere implantation. The blastomere from genetically pigmented zebrafish embryos at mid-blastula stage were transplanted into an albino recipient embryo of the same developmental stage. In five out of the twenty-eight chimeric fish produced, blastomeres from the donor contributed to the germline, transmitting the pigmented phenotype to the next generation at a frequency of 1% to 40% (Lin et al., 1992). Slowly cooled zebrafish (*Danio rerio*) blastomeres, isolated from 50% epiboly, were cryopreserved with 1.5M DMSO and 0.1M sucrose in 0.25 ml straws by a programmable freezer. A survival rate of 70% was obtained after thawing (Lin et al., 2009). Combining these technologies, the germline transmission of the cryopreserved genetic materials through blastomeres-embryo chimera seems to be possible. More optimization, e.g., the stages from which the blastomeres are to be isolated, is needed to maximize germline transmission and to minimize operations to be conducted in a recovery procedure.

Another alternative diploid material often sought to be cryopreserved is the primordial germ cells. Compared with the blastomere, primordial germ cells are developmentally closer to the cell type to be differentiated *in vivo*, i.e. the germ cells. The first success in transplantation of primordial germ cells was demonstrated on rainbow trout (*Oncorhynchus mykiss*), a model with a relatively larger body size. Green fluorescent protein expressing primordial germ cells isolated from the genital ridge of hatchlings were injected into the peritoneal cavities of a wild type hatchling. The marker-labeled primordial germ cells were able to colonize the genital ridge of the recipient animal and transmit the donor characteristic to the next generation through sperm and eggs at a rate of up to about 4% (Takeuchi et al., 2003).

A similar operation in the smaller teleost species such as zebrafish is more challenging. A single primordial germ cell isolated from the pearl *Danio* (*Danio albolineatus*) at ten- to fifteen-somite stage was transplanted into the marginal region of each zebrafish (*Danio rerio*) embryo at the blastula stage and *vice versa*. The development of host germ cells was prevented in advance by injection of an antisense *dead end* morpholino oligonucleotide at an earlier embryonic stage (Slanchev et al., 2005). In the host, the transplanted primordial germ cell developed into a single gonad, making the animal regain fertility and transmit the donor genotype to the progenies. This complete germline replacement procedure can be applied to both goldfish (*Carassius auratus*) and loach (*Misgurnus anguillicaudatus*) (Saito et al., 2008). The success of these cases suggests that cryopreservation of primordial germ cells is a feasible approach to preserve the diploid germplasm. As the reservoirs of primordial germ cells, genital ridges from Rainbow trout (*Oncorhynchus mykiss*) embryos were cryopreserved by cooling in dry ice and then liquid nitrogen after treating with 1.8M ethylene glycol. About 51% of primordial germ cells survived. Fifteen to twenty surviving primordial germ cells were transplanted to the peritoneal cavity of each newly hatched animal. Germline transmission of the donor genotype could be found in 7.8% of the hosts and the germline transmission frequency was from 0.1 to 13.5%. (Kobayashi et al., 2007).

Later, Higaki et al. (2010b) vitrified whole zebrafish (*Danio rerio*) embryos at 14- to 20-somite stage with an optimized vitrification solution to cryopreserve primordial germ cells. With the use of 3M ethylene glycol and 0.5M sucrose, about 4 primordial germ cells, about 40% of all, survived in each embryo, after thawing. To increase cryo-survival, yolk-removed zebrafish (*Danio rerio*) embryos were vitrified in 20% ethylene glycol, 20% DMSO and 0.5M sucrose. Up to 90% live primordial germ cells were obtained. Half of the primordial germ cells retained pseudopodial movement. After transplanting the motile primordial germ cells into sterilized golden-type zebrafish blastulae, about 2.8% of the recipients developed normally and produced progenies with the donor's genotype (Higaki et al., 2010a).

Unless there is a breakthrough in cryopreserving and recovering whole fish embryos, cryopreservation of blastomeres or primordial germ cells seem to be the only methods for cryopreserving the fish diploid germplasm. Blastomeres may have advantages over primordial germ cells in generating germline transmitting chimera. Firstly, identification and isolation of primordial germ cells relies on a readily observable transgenic marker (Higaki et al., 2010b; Kobayashi et al., 2007). Breeding of a strain to a marker transgenic strain or freshly injecting DNA constructs is required before cryopreservation procedures, making the procedures more complicated. Removal of the marker from the recovered animals may also be required in some applications. Secondly, for germ-line replacement, the

recipient blastulae have to be sterilized, e.g., by injecting a *dead end* antisense morpholino (Ciruna et al., 2002). This demands additional procedures in the entire cryopreservation/recovery cycle, making the primordial germ cell-base approach less attractive than the existing sperm cryopreservation. Delivery of antifreezing proteins to directly minimize water crystal formation or aquaporins to increase permeability to cryoprotectants and movement of water (Chauvigne et al., 2011) through transgenesis similarly complicate the cryopreservation procedures.

## 6. Concluding remarks

Successful cryopreservation relies on a number of conditions and properties of the embryos or larvae to be fulfilled. The conditions, which may be interdependent on each other, are (1) the chilling sensitivity of the embryos/larvae; (2) the permeability of the embryos/larvae to cryoprotectant and water; and (3) the sensitivity of the embryos/larvae to the cryoprotectant toxicity. The permeability of the embryos/larvae can be a function of size and structural heterogeneity. The toxicity of the cryoprotectant to the embryos/larvae can be a function of permeability at a particular developmental stage. Although a cryopreservation protocol can be as simple as slow freezing *Caenorhabditis elegans* in 15% glycerol, most of the other organisms require extensive optimization before being cryopreserved efficiently. Understanding the behavior of the interacting conditions can help initiate the development of cryopreservation of other model animals.

*Chilling injury* We learned from classical model organisms that chilling sensitivity coupled with a slow cooling procedure could be detrimental and vitrification can be a shortcut or even a better starting point to achieve the same goal. Vitrification of highly chilling-sensitive insect embryos is an excellent example. On the other hand, we have to keep in mind that vitrification requires a relatively high concentration of permeating cryoprotectant(s). If a new model organism to be cryopreserved is highly sensitive to the cryoprotectant(s) and has relatively low permeability, vitrification may not be feasible. Slow cooling, which requires a lower concentration of cryoprotectant, thus also allowing longer time for permeation, may be considered.

*Permeability* The permeability of a sample towards cryoprotectants is the major barrier to cryopreservation of *Drosophila melanogaster*, *Danio rerio* and probably some other model organisms. Understanding the complexity and structural properties of the embryo/larvae can make cryopreservation possible by developing a corresponding strategy to manage the flow of cryoprotecting agents and water at will. Although the studies on *Danio rerio* embryo complexity and development did not bring about successful cryopreservation of the whole embryo, they helped development of alternatives for cryopreserving diploidic germplasm. Cryopreservation of blastomeres and primordial germ cells using the optimized conditions leads to generation of germline-transmitting chimera after transplantation of cells.

*Toxicity of cryoprotectants* Knowing the toxicity of cryoprotectants at different developmental stages of an organism is critical in determining the combination of cryoprotectants with embryonic/larval stages to be chosen for effective cryopreservation during protocol development. For example, glycerol and dimethylformamide are very toxic to fish embryos and mammalian morulae, respectively (Higaki et al., 2010b; Kasai et al., 1981).

Model organisms offer a platform to address biological issues of a broad range of interests with ease. An ideal platform must have specific traits allowing convenient manipulations in a manner beneficial to specific fields of study. Use of classical model organisms such as the house mouse *Mus musculus*, zebrafish *Danio rerio*, fruit fly *Drosophila melanogaster* and nematode *Caenorhabditis elegans* for studying physiology, genetics, genomics, behavior, human diseases and their treatments, etc is well established. These are attractive model organisms from their representative evolutionary position. They are relatively more readily available, tractable, small in body size, rapid in development and have short reproductive cycles. They are still popular models because of the establishment of transgenic technologies related to these animals (Fire, 1986; Gordon et al., 1980; Rubin & Spradling, 1982; Zelenin et al., 1991). Such genome manipulation technologies make reverse genetics possible, allowing studies to be amendable for these model organisms.

Knowledge gained on the above-mentioned classical models and other less popular model organisms has been expanding for the past few decades. Thorough comparative studies in various fields of research will benefit translational research and our understanding of the evolutionary tree of life. More interdisciplinary studies on model organisms representing animals in various branches of the phylogenetic tree will enhance our comparative study. Promising transgenic techniques have been recently established in respect of some of these animals, e.g., planaria *Girardia tigrina*, brine shrimp *Artemia sinica*, amphipod crustacean *Parhyale hawaiiensis*, red flour beetle *Tribolium castaneum*, sea anemone *Nematostella vectensis*, Mollusk dwarf surfclam *Mulinia lateralis*, sea squirt *Ciona intestinalis*, channel catfish *Ictalurus punctatus*, frog *Xenopus laevis* and *Xenopus tropicalis*, chicken *Gallus gallus*, Japanese quail *Coturnix japonica*, goat *Capra hircus*, dog *Canis familiaris* and marmoset *Callithrix jacchus*, (Berghammer et al., 1999; Chang et al., 2011; Dunham et al., 2002; Gonzalez-Estevez et al., 2003; Hong et al., 2009; Houdebine, 2009; Huss et al., 2008; Lu et al. 1996; Macha et al., 1997; Mozdziak & Petite 2004 ; Pavlopoulos and Averof, 2005; Renfer et al., 2010; Sasaki et al., 2009; Sasakura et al., 2007; Wheeler, 2003). The development of genome manipulation techniques for these emerging animal models will open the door to unlimited possibilities of *in vivo* investigations.

The cost of the knowledge explosion and scientific advancement will be the handling of an enormous number of transgenic strains generated. The cost of managing these invaluable resources can be a substantial burden on research laboratories or institutions world wide, which may impede further development. So far cryopreservation has been developed for embryos/larvae from non-classical model animals, including oyster *Crassostrea gigas*, hard clam *Meretrix lusoria*, sea urchin *Loxechinus albus*, amphioxus *Branchiostoma belcheri*, brine shrimp *Artemia franciscana*, euryhaline rotifer *Brachionus plicatilis* and marmoset *Callithrix jacchus*, etc. (Barros et al., 1997; Chao et al., 1997; Summers et al., 1987; Sun et al., 2007; Toleda & Kurokura, 1990; Yoshida et al., 2011).

The experience in cryopreserving embryos from such a broad evolutionary range will benefit the development of cryopreservation techniques in other emerging model organisms. The parameters highlighted in this review represent some keys for developing an effective cryopreservation protocol for any organisms for experimental use. The thorough understanding of these parameters in different model systems, the optimization therein, and improved procedures to store transgenic strains will not only release the management stress caused by the need for keeping the live animals but also eliminate the risk of their being affected by disease outbreaks and genetic drifts. It has great practical

value for short term research purposes and daily operations. It is also beneficial for a longer term establishment of these models as alternative platforms for biomedical investigations.

## 7. Acknowledgement

We would like to thank Miss Mandy Chan and Prof. Andrew L. Miller (HKUST) for contribution to the photograph of a zebrafish embryo in Figure 3C. FlyMove, an internet educational resource (Weigmann 2003), is acknowledged for the permission in reproducing an image of a fly embryo in Figure 3B. WHT is a postdoctoral fellow supported by HKUST postdoctoral fellowship. This work was conducted and supported by Research Grants Council (HKUST 660407 and 660508).

## 8. References

- Bai, C., Shapiro-Ilan, D.I., Gaugler, R. & Yi, S. (2004). Effect of entomopathogenic nematode concentration on survival during cryopreservation in liquid nitrogen. *Journal of Nematology*, Vol. 36, pp. (281-284).
- Ballweber, P., Markl, J. & Burmester, T. (2002). Complete hemocyanin subunit sequences of the hunting spider *Cupiennius salei*: Recent hemocyanin remodeling in entelegyne spiders. *The Journal of Biological Chemistry*, Vol. 277, pp. (14451-14457).
- Barros, C., Muller, A. & Wood, M.J. (1997). High survival of spermatozoa and pluteus larvae of sea urchins frozen in Me<sub>2</sub>SO. *Cryobiology*, Vol. 35, pp. (341).
- Beament, J.W.L. (1946). The waterproofing process in eggs of *Rhadnius prolius* Stahl. *Proceedings of the Royal Society B: Biological Science*, Vol. 133, pp. (407-418).
- Berghammer, A.J., Klingler, M. & Wimmer, E.A. (1999). A universal marker for transgenic insects. *Nature*, Vol. 402, pp. (370-371).
- Borgsteede, F.H. & Hendriks, J. (1979). Experimental infections with *Cooperia oncophora* (Railliet, 1918) in calves. Results of single infections with two graded dose levels of larvae. *Parasitology*, Vol. 78, pp. (331-342).
- Brenner, S. (1974). The genetics of *Caenorhabditis elegans*. *Genetics*, Vol. 77, pp. (71-94).
- Bridge, J. & Ham, P.J. (1985). A technique for the cryopreservation of viable juveniles of *Meloidogyne graminicola*. *Nematologica*, Vol. 31, pp. (185-189).
- Campbell, W.C. & Thomson, B.M. (1973). Survival of nematode larvae after freezing over liquid nitrogen. *Australian Veterinary Journal*, Vol. 49, pp. (110-111).
- Chang, S.H., Lee, B.C., Chen, Y.D., Lee, Y.C. & Tsai, H.J. (2011). Development of transgenic zooplankton *Artemia* as a bioreactor to produce exogenous protein. *Transgenic Research*, (Jan2011). 1573-9368.
- Chao, N.H., Lin, T.T., Chen, Y.J., Hsu, W.H. & Liao, I.C. (1997). Cryopreservation of the late embryos and early larvae in the oyster and hard clam. *Aquaculture*, Vol. 155, pp. (31-44).
- Chauvigne, F., Lubzens, E. & Cerda, J. (2011). Design and characterization of genetically engineered zebrafish *aquaporin-3* mutants highly permeable to the cryoprotectant ethylene glycol. *BMC Biotechnology*, Vol. 11, pp. (34).
- Ciruna, B., Weidinger, G., Knaut, H., Thisse, B., Thisse, C., Raz, E. & Schier, A.F. (2002). Production of maternal-zygotic mutant zebrafish by germ-line replacement.

- Proceedings of the National Academy of Sciences of the United States of America*, Vol. 99, pp. (14919-14924).
- Cohen, J., Simons, R.F., Fehilly, C.B., Fishel, S.B., Edwards, R.G., Hewitt, J., Rowland, G.F., Steptoe, P.C. & Webster, J.M. (1985). Birth after replacement of hatching blastocyst cryopreserved at expanded blastocyst stage. *Lancet*, Vol. 1, pp. (647).
- Collins, A.M. & Mazur, P. (2006). Chill sensitivity of honey bee, *Apis mellifera*, embryos. *Cryobiology*, Vol. 53, pp. (22-27).
- Cosi, E., Abidalla, M.T. & Roversi, P.F. (2010). The effect of Tween 80 on eggshell permeabilization in *Galleria mellonella* (L.) (Lepidoptera, pyralidae). *CryoLetters*, Vol. 31, pp. (291-300).
- Curran, J., Gilbert, C. & Butler, K. (1992). Routine cryopreservation of isolates of *Steinernema* and *Heterorhabditis* spp. *Journal of Nematology*, Vol. 24, pp. (269-270).
- Downing, B.G., Mohr, L.R., Trounson, A.O., Freemann, L.E. & Wood, C. (1985). Birth after transfer of cryopreserved embryos. *The Medical Journal of Australia*, Vol. 142, pp. (409-411).
- Drake, J.W., Charlesworth, B., Charlesworth, D. & Crow, J.F. (1998). Rates of spontaneous mutation. *Genetics*, Vol. 148, pp. (1667-1686).
- Dunham, R.A., Warr, G.W., Nichols, A., Duncan, P.L., Argue, B., Middleton, D. & Kucuktas, H. (2002). Enhanced bacterial disease resistance of transgenic channel catfish *Ictalurus punctatus* possessing cecropin genes. *Marine Biotechnology*, Vol. 4, pp. (338-344).
- Emiliani, S., Van den Bergh, M., Vannin, A.S., Biramane, J. & Englert, Y. (2000). Comparison of ethylene glycol, 1,2-propanediol and glycerol for cryopreservation of slow-cooled mouse zygotes, 4-cell embryos and blastocysts. *Human Reproduction*, Vol. 15, pp. (905-910).
- Eppig, J.T. & Strivens, M. (1999). Finding a mouse: The international mouse strain resource (IMSR). *Trends in Genetics*, Vol. 15, pp. (81-82).
- Fehrenbach, H. (1995). Egg shells of *Lepidoptera* - fine structure and phylogenetic implications. *Zoologischer Anzeiger*, Vol. 234, pp. (19-41).
- Fire, A. (1986). Integrative transformation of *Caenorhabditis elegans*. *The EMBO Journal*, Vol. 5, pp. (2673-2680).
- Gengyo-Ando, K. & Mitani, S. (2000). Characterization of mutations induced by ethyl methanesulfonate, UV, and trimethylpsoralen in the nematode *Caenorhabditis elegans*. *Biochemical and Biophysical Research Communications*, Vol. 269, pp. (64-69).
- Gill, J.H. & Redwin, J.M. (1995). Cryopreservation of the first-stage larvae of trichostrongylid nematode parasites. *International Journal for Parasitology*, Vol. 25, pp. (1421-1426).
- Gonzalez-Estevez, C., Momose, T., Gehring, W.J. & Salo, E. (2003). Transgenic planarian lines obtained by electroporation using transposon-derived vectors and an eye-specific GFP marker. *Proceedings of the National Academy of Sciences of the United States of America*, Vol. 100, pp. (14046-14051).
- Gordon, J.W., Scangos, G.A., Plotkin, D.J., Barbosa, J.A. & Ruddle, F.H. (1980). Genetic transformation of mouse embryos by microinjection of purified DNA. *Proceedings of the National Academy of Sciences of the United States of America*, Vol. 77, pp. (7380-7384).

- Grumbling, G. & Strelets, V. (2006). FlyBase: Anatomical data, images and queries. *Nucleic Acids Research*, Vol. 34, pp. (D484-8).
- Hagedorn, M., Hsu, E.W., Pilatus, U., Wildt, D.E., Rall, W.R. & Blackband, S.J. (1996). Magnetic resonance microscopy and spectroscopy reveal kinetics of cryoprotectant permeation in a multicompartmental biological system. *Proceedings of the National Academy of Sciences of the United States of America*, Vol. 93, pp. (7454-7459).
- Hagedorn, M., Hsu, E., Kleinhans, F.W. & Wildt, D.E. (1997a). New approaches for studying the permeability of fish embryos: Toward successful cryopreservation. *Cryobiology*, Vol. 34, pp. (335-347).
- Hagedorn, M., Kleinhans, F.W., Freitas, R., Liu, J., Hsu, E.W., Wildt, D.E. & Rall, W.F. (1997b). Water distribution and permeability of zebrafish embryos, *Brachydanio rerio*. *The Journal of Experimental Zoology*, Vol. 278, pp. (356-371).
- Hagedorn, M., Kleinhans, F.W., Wildt, D.E. & Rall, W.F. (1997c). Chill sensitivity and cryoprotectant permeability of dechorionated zebrafish embryos, *Brachydanio rerio*. *Cryobiology*, Vol. 34, pp. (251-263).
- Haight, M., Frim, J., Pasternak, J. & Frey, H. (1975). Freeze-thaw survival of the free-living nematode *Caenorhabditis briggsae*. *Cryobiology*, Vol. 12, pp. (497-505).
- Ham, P.J., Townson, S., James, E.R. & Bianco, A.E. (1981). An improved technique for the cryopreservation of onchocerca microfilariae. *Parasitology*, Vol. 83, pp. (139-146).
- Harvey, B., Kelley, R.N. & Ashwood-Smith, M.J. (1983). Permeability of intact and dechorionated zebra fish embryos to glycerol and dimethyl sulfoxide. *Cryobiology*, Vol. 20, pp. (432-439).
- Higaki, S., Eto, Y., Kawakami, Y., Yamaha, E., Kagawa, N., Kuwayama, M., Nagano, M., Katagiri, S. & Takahashi, Y. (2010a). Production of fertile zebrafish (*Danio rerio*) possessing germ cells (gametes) originated from primordial germ cells recovered from vitrified embryos. *Reproduction*, Vol. 139, pp. (733-740).
- Higaki, S., Mochizuki, K., Akashi, Y., Yamaha, E., Katagiri, S. & Takahashi, Y. (2010b). Cryopreservation of primordial germ cells by rapid cooling of whole zebrafish (*Danio rerio*) embryos. *The Journal of Reproduction and Development*, Vol. 56, pp. (212-218).
- Hong, S.G., Kim, M.K., Jang, G., Oh, H.J., Park, J.E., Kang, J.T., Koo, O.J. *et al.* (2009). Generation of red fluorescent protein transgenic dogs. *Genesis*, Vol. 47, pp. (314-322).
- Houdebine, L.M. (2009). Production of pharmaceutical proteins by transgenic animals. *Comparative Immunology, Microbiology and Infectious Diseases*, Vol. 32, pp. (107-121).
- Huss, D., Poynter, G. & Lansford, R. (2008). Japanese quail (*Coturnix japonica*) as a laboratory animal model. *Lab Animal*, Vol. 37, pp. (513-519).
- Hwang, S.W. (1970). Freezing and storage of nematodes in liquid nitrogen. *Nematologica*, Vol. 16, pp. (305-308).
- Jagdale, G.B. & Grewal, P.S. (2003). Acclimation of entomopathogenic nematodes to novel temperatures: Trehalose accumulation and the acquisition of thermotolerance. *International Journal for Parasitology*, Vol. 33, pp. (145-152).
- James, E.R. (1981). *Schistosoma mansoni*: Cryopreservation of schistosomula by two-step addition of ethanediol and rapid cooling. *Experimental Parasitology*, Vol. 52, pp. (105-116).

- James, E.R. (1985). Cryopreservation of helminths. *Parasitology Today*, Vol. 1, pp. (134-139).
- Kasai, M., Niwa, K. & Iritani, A. (1981). Effects of various cryoprotective agents on the survival of unfrozen and frozen mouse embryos. *Journal of Reproduction and Fertility*, Vol. 63, pp. (175-180).
- Katkov, I.I. & Pogorelov, A.G. (2007). Influence of exposure to vitrification solutions on 2-cell mouse embryos: II. osmotic effects or chemical toxicity? *CryoLetters*, Vol. 28, pp. (409-427).
- Keskintepe, L., Sher, G., Machnicka, A., Tortoriello, D., Bayrak, A., Fisch, J. & Agca, Y. (2009). Vitrification of human embryos subjected to blastomere biopsy for pre-implantation genetic screening produces higher survival and pregnancy rates than slow freezing. *Journal of Assisted Reproduction and Genetics*, Vol. 26, pp. (629-635).
- Kimmel, C.B., Ballard, W.W., Kimmel, S.R., Ullmann, B. & Schilling, T.F. (1995). Stages of embryonic development of the zebrafish. *Developmental Dynamics : An Official Publication of the American Association of Anatomists*, Vol. 203, pp. (253-310).
- Kobayashi, T., Takeuchi, Y., Takeuchi, T. & Yoshizaki, G. (2007). Generation of viable fish from cryopreserved primordial germ cells. *Molecular Reproduction and Development*, Vol. 74, pp. (207-213).
- Kohli, V., Robles, V., Cancela, M.L., Acker, J.P., Waskiewicz, A.J. & Elezzabi, A.Y. (2007). An alternative method for delivering exogenous material into developing zebrafish embryos. *Biotechnology and Bioengineering*, Vol. 98, pp. (1230-1241).
- Kosik, K.S. (2009). MicroRNAs tell an evo-devo story. *Nature Reviews.Neuroscience*, Vol. 10, No. 10, (Oct), pp. (754-759).
- Krzyszynska, U. & O'Neill, C. (1991). The effects of cryopreservation and thawing on the development in vitro and in vivo of biopsied 8-cell mouse embryos. *Human Reproduction*, Vol. 6, pp. (832-835).
- Kuwayama, M., Vajta, G., Kato, O. & Leibo, S.P. (2005). Highly efficient vitrification method for cryopreservation of human oocytes. *Reproductive Biomedicine Online*, Vol. 11, pp. (300-308).
- Lane, M., Schoolcraft, W.B. & Gardner, D.K. (1999). Vitrification of mouse and human blastocysts using a novel cryoloop container-less technique. *Fertility and Sterility*, Vol. 72, pp. (1073-1078).
- Lee, H.J., Elmoazzen, H., Wright, D., Biggers, J., Rueda, B.R., Heo, Y.S., Toner, M. & Toth, T.L. (2010). Ultra-rapid vitrification of mouse oocytes in low cryoprotectant concentrations. *Reproductive Biomedicine Online*, Vol. 20, pp. (201-208).
- Leung, C.F., Webb, S.E. & Miller, A.L. (1998). Calcium transients accompany ooplasmic segregation in zebrafish embryos. *Development, Growth & Differentiation*, Vol. 40, pp. (313-326).
- Limbourg, B. & Zalokar, M. (1973). Permeabilization of *Drosophila* eggs. *Developmental Biology*, Vol. 35, pp. (382-387).
- Lin, S., Long, W., Chen, J. & Hopkins, N. (1992). Production of germ-line chimeras in zebrafish by cell transplants from genetically pigmented to albino embryos. *Proceedings of the National Academy of Sciences of the United States of America*, Vol. 89, pp. (4519-4523).
- Lin, C., Zhang, T. & Rawson, D.M. (2009). Cryopreservation of zebrafish (*Danio rerio*) blastomeres by controlled slow cooling. *CryoLetters*, Vol. 30, pp. (132-141).



- Liu, J., Van den Abbeel, E. & Van Steirteghem, A. (1993). The in-vitro and in-vivo developmental potential of frozen and non-frozen biopsied 8-cell mouse embryos. *Human Reproduction*, Vol. 8, pp. (1481-1486).
- Leopold, R.A. & Atkinson, P.W.(1999). Cryopreservation of sheep blow fly embryos, *Lucilia cuprina* (Diptera: Calliphoridae). *CryoLetters*, Vol. 20, pp. (37-44).
- Leopold, R.A., Wang, W.B., Berkebile, D.R. & Freeman T.P.(2001). Cryopreservation of embryos of the new world screwworm *Cochliomyia hominivorax* (diptera: calliphoridae). *Annals of the Entomological Society of America*, Vol. 94, pp. (695-701).
- Lu, J.K., Chen, T.T., Allen, S.K., Matsubara, T. & Burns, J.C. (1996). Production of transgenic dwarf surfclams, *Mulinia lateralis*, with pantropic retroviral vectors. *Proceedings of the National Academy of Sciences of the United States of America*, Vol. 93, pp. (3482-3486).
- Lynch, D.V., Lin, T.T., Myers, S.P., Leibo, S.P., Macintyre, R.J., Pitt, R.E. & Steponkus, P.L. (1989). A two-step method for permeabilization of *Drosophila* eggs. *Cryobiology*, Vol. 26, pp. (445-452).
- Macha, J., Stursova, D., Takac, M., Habrova, V. & Jonak, J. (1997). Uptake of plasmid RSV DNA by frog and mouse spermatozoa. *Folia Biologica*, Vol. 43, pp. (123-127).
- Manipalviratn, S., DeCherney, A. & Segars, J. (2009). Imprinting disorders and assisted reproductive technology. *Fertility and Sterility*, Vol. 91, pp. (305-315).
- Margaritis, L.H., Kafatos, F.C. & Petri, W.H. (1980). The eggshell of *Drosophila melanogaster*. I. fine structure of the layers and regions of the wild-type eggshell. *Journal of Cell Science*, Vol. 43, pp. (1-35).
- Markow, T.A., Beall, S. & Matzkin, L.M. (2009). Egg size, embryonic development time and ovoviviparity in *Drosophila* species. *Journal of Evolutionary Biology*, Vol. 22, pp. (430-434).
- Martino, A., Songsasen, N. & Leibo, S.P. (1996). Development into blastocysts of bovine oocytes cryopreserved by ultra-rapid cooling. *Biology of Reproduction*, Vol. 54, pp. (1059-1069).
- Matsumoto, H., Jiang, J.Y., Tanaka, T., Sasada, H. & Sato, E. (2001). Vitrification of large quantities of immature bovine oocytes using nylon mesh. *Cryobiology*, Vol. 42, pp. (139-144).
- Mazur, P. & Schneider, U. (1986). Osmotic responses of preimplantation mouse and bovine embryos and their cryobiological implications. *Cell Biophysics*, Vol. 8, pp. (259-285).
- Mazur, P., Cole, K.W., Hall, J.W., Schreuders, P.D. & Mahowald, A.P. (1992a). Cryobiological preservation of *Drosophila* embryos. *Science (New York, N.Y.)*, Vol. 258, pp. (1932-1935).
- Mazur, P., Cole, K.W. & Mahowald, A.P. (1992b). Critical factors affecting the permeabilization of *Drosophila* embryos by alkanes. *Cryobiology*, Vol. 29, pp. (210-239).
- Mazur, P., Schneider, U. & Mahowald, A.P. (1992c). Characteristics and kinetics of subzero chilling injury in *Drosophila* embryos. *Cryobiology*, Vol. 29, pp. (39-68).
- Mozdziak, P.E. & Petitte, J.N. (2004). Status of transgenic chicken models for developmental biology. *Developmental Dynamics*, Vol. 229, pp. (414-421).

- Nelson, D.R. & Leopold, R.A. (2003). Composition of the surface hydrocarbons from the vitelline membranes of dipteran embryos. *Comparative Biochemistry and Physiology. Part B, Biochemistry & Molecular Biology*, Vol. 136, pp. (295-308).
- Nolan, T.J., Aikens, L.M. & Schad, G.A. (1988). Cryopreservation of first-stage and infective third-stage larvae of *Strongyloides stercoralis*. *The Journal of Parasitology*, Vol. 74, pp. (387-391).
- Nugent, M.J., O'Leary, S.A. & Burnell, A.M. (1996). Optimised procedures for the cryopreservation of different species of *Heterorhabditis*. *Fundamental and Applied Nematology*, Vol. 19, pp. (1-6).
- Nunamaker, R.A. & Lockwood, J.A. (2001). Cryopreservation of embryos of *Culicoides sonorensis* (Diptera: Ceratopogonidae). *Journal of Medical Entomology*, Vol. 38, pp. (55-58).
- Papassideri, I., Margaritis, L.H. & Gulik-Krzywicki, T. (1991). The egg-shell of *Drosophila melanogaster*. VI, structural analysis of the wax layer in laid eggs. *Tissue & Cell*, Vol. 23, pp. (567-575).
- Papassideri, I.S. & Margaritis, L.H. (1996). The eggshell of *Drosophila melanogaster*: IX. synthesis and morphogenesis of the innermost chorionic layer. *Tissue & Cell*, Vol. 28, pp. (401-409).
- Parriego, M., Sole, M., Aurell, R., Barri, P.N. & Veiga, A. (2007). Birth after transfer of frozen-thawed vitrified biopsied blastocysts. *Journal of Assisted Reproduction and Genetics*, Vol. 24, pp. (147-149).
- Pavlopoulos, A. & Averof, M. (2005). Establishing genetic transformation for comparative developmental studies in the crustacean *Parhyale hawaiiensis*. *Proceedings of the National Academy of Sciences of the United States of America*, Vol. 102, pp. (7888-7893).
- Pedro, P.B., Yokoyama, E., Zhu, S.E., Yoshida, N., Valdez, D.M., Jr, Tanaka, M., Edashige, K. & Kasai, M. (2005). Permeability of mouse oocytes and embryos at various developmental stages to five cryoprotectants. *The Journal of Reproduction and Development*, Vol. 51, pp. (235-246).
- Pogorelov, A.G., Katkov, I.I. & Pogorelova, V.N. (2007). Influence of exposure to vitrification solutions on 2-cell mouse embryos: I. intracellular potassium and sodium content. *CryoLetters*, Vol. 28, pp. (403-408).
- Pogorelov, A.G., Katkov, I.I., Smolyaninova, E.I. & Goldshtein, D.V. (2006). Changes in intracellular potassium and sodium content of 2-cell mouse embryos induced by exposure to vitrification concentrations of ethylene glycol. *CryoLetters*, Vol. 27, pp. (87-98).
- Popiel, I. & Vasquez, E.M. (1991). Cryopreservation of *Steinernema carpocapsae* and *Heterorhabditis bacteriophora*. *Journal of Nematology*, Vol. 23, pp. (432-437).
- Qiu, L. & Bedding, R.A. (2002). Characteristics of protectant synthesis of infective juveniles of *Steinernema carpocapsae* and importance of glycerol as a protectant for survival of the nematodes during osmotic dehydration. *Comparative Biochemistry and Physiology. Part B, Biochemistry & Molecular Biology*, Vol. 131, pp. (757-765).
- Rall, W.F. & Fahy, G.M. (1985). Ice-free cryopreservation of mouse embryos at -196 degrees C by vitrification. *Nature*, Vol. 313, pp. (573-575).
- Rall, W.F. (1987). Factors affecting the survival of mouse embryos cryopreserved by vitrification. *Cryobiology*, Vol. 24, pp. (387-402).

- Rawson, D.M., Zhang, T., Kalicharan, D. & Jongebloed, W.L. (2000). FESEM and TEM studies of the chorion, plasma membrane and syncytial layers of the gastrula stage embryo of the zebrafish (*Brachydanio rerio*): A consideration of the structural and functional relationship with respect to cryoprotectant penetration. *Aquaculture Research*, Vol. 31, pp. (325-336).
- Renfer, E., Amon-Hassenzahl, A., Steinmetz, P.R. & Technau, U. (2010). A muscle-specific transgenic reporter line of the sea anemone, *Nematostella vectensis*. *Proceedings of the National Academy of Sciences of the United States of America*, Vol. 107, pp. (104-108).
- Robles, V., Cabrita, E., de Paz, P., Cunado, S., Anel, L. & Herraez, M.P. (2004). Effect of a vitrification protocol on the lactate dehydrogenase and glucose-6-phosphate dehydrogenase activities and the hatching rates of zebrafish (*Danio rerio*) and turbot (*Scophthalmus maximus*) embryos. *Theriogenology*, Vol. 61, pp. (1367-1379).
- Rubin, G.M. & Spradling, A.C. (1982). Genetic transformation of *Drosophila* with transposable element vectors. *Science*, Vol. 218, pp. (348-353).
- Saito, T., Goto-Kazeto, R., Arai, K. & Yamaha, E. (2008). Xenogenesis in teleost fish through generation of germ-line chimeras by single primordial germ cell transplantation. *Biology of Reproduction*, Vol. 78, pp. (159-166).
- Saragusty, J. & Arav, A. (2011). Current progress in oocyte and embryo cryopreservation by slow freezing and vitrification. *Reproduction*, Vol. 141, pp. (1-19).
- Sasaki, K., Kurokura, H. & Kasahara, S. (1988). Changes in low temperature tolerance of the eggs of certain marine fish during embryonic development. *Comparative Biochemistry and Physiology*, Vol. 91A, pp. (183-187).
- Sasaki, E., Suemizu, H., Shimada, A., Hanazawa, K., Oiwa, R., Kamioka, M., Tomioka, I. *et al.* (2009). Generation of transgenic non-human primates with germline transmission. *Nature*, Vol. 459, pp. (523-527).
- Sasakura, Y., Oogai, Y., Matsuoka, T., Satoh, N. & Awazu, S. (2007). Transposon mediated transgenesis in a marine invertebrate chordate: *Ciona intestinalis*. *Genome Biology*, Vol. 8 Suppl 1, pp. (S3).
- Scavarda, N.J. & Hartl, D.L. (1984). Interspecific DNA transformation in *Drosophila*. *Proceedings of the National Academy of Sciences of the United States of America*, Vol. 81, pp. (7515-7519).
- Schreuders, P.D., Kassis, J., Cole, K.W., Schneider, U., Mahowald, A.P. & Mazur, P. (1996). Kinetics of embryo drying in *Drosophila melanogaster* as a function of the steps of permeabilization: Experimental. *Journal of Insect Physiology*, Vol. 42, pp. (501-516).
- Shapiro, D.I., Glazer, I. & Segal, D. (1996). Trait stability and fitness of the heat tolerant entomopathogenic nematode *Heterorhabditis bacteriophora* IS5 strain. *Biological Control*, Vol. 6, pp. (238-244).
- Skarnes, W.C., Rosen, B., West, A.P., Koutsourakis, M., Bushell, W., Iyer, V., Mujica, A.O. *et al.* (2011). A conditional knockout resource for the genome-wide study of mouse gene function. *Nature*, Vol. 474, pp. (337-342).
- Slanchev, K., Stebler, J., de la Cueva-Mendez, G. & Raz, E. (2005). Development without germ cells: The role of the germ line in zebrafish sex differentiation. *Proceedings of the National Academy of Sciences of the United States of America*, Vol. 102, pp. (4074-4079).

- Slifer, E.H. (1948). Isolation of a wax-like material from the shell of the grasshopper egg. *Discussions of the Faraday Society*, Vol. 3, pp. (182-187).
- Snabes, M.C., Cota, J. & Hughes, M.R. (1993). Cryopreserved mouse embryos can successfully survive biopsy and refreezing. *Journal of Assisted Reproduction and Genetics*, Vol. 10, pp. (513-516).
- Songsasen, N., Buckrell, B.C., Plante, C. & Leibo, S.P. (1995). In vitro and in vivo survival of cryopreserved sheep embryos. *Cryobiology*, Vol. 32, No. 1, (Feb), pp. (78-91).
- Steponkus, P.L., Myers, S.P., Lynch, D.V., Gardner, L., Bronshteyn, V., Leibo, S.P., Rall, W.F., Pitt, R.E., Lin, T.T. & MacIntyre, R.J. (1990). Cryopreservation of *Drosophila melanogaster* embryos. *Nature*, Vol. 345, pp. (170-172).
- Stevens, J.C., Banks, G.T., Festing, M.F. & Fisher, E.M. (2007). Quiet mutations in inbred strains of mice. *Trends in Molecular Medicine*, Vol. 13, pp. (512-519).
- Stuart, R.J. & Gaugler, R. (1996). Genetic adaptation and founder effect in laboratory populations of the entomopathogenic nematode *Steinernema glaseri*. *Canadian Journal of Zoology*, Vol. 74, pp. (164-170).
- Sugiyama, R., Nakagawa, K., Shirai, A., Sugiyama, R., Nishi, Y., Kuribayashi, Y. & Inoue, M. (2010). Clinical outcomes resulting from the transfer of vitrified human embryos using a new device for cryopreservation (plastic blade). *Journal of Assisted Reproduction and Genetics*, Vol. 27, pp. (161-167).
- Summers, P.M., Shephard, A.M., Taylor, C.T. & Hearn, J.P. (1987). The effects of cryopreservation and transfer on embryonic development in the common marmoset monkey, *Callithrix jacchus*. *Journal of Reproduction and Fertility*, Vol. 79, pp. (241-250).
- Sun, Y., Zhang, Q.J. & Wang, Y.Q. (2007). Programmed cryopreservation of the amphioxus *Branchiostoma belcheri* embryos. *Current Zoology*, Vol. 53, pp. (524-530).
- Takeuchi, Y., Yoshizaki, G. & Takeuchi, T. (2003). Generation of live fry from intraperitoneally transplanted primordial germ cells in rainbow trout. *Biology of Reproduction*, Vol. 69, pp. (1142-1149).
- Toledo, J.D. & Kurokura, H. (1990). Cryopreservation of the euryhaline rotifer *Brachionus plicatilis*. *Aquaculture*, Vol. 91, pp. (385-394).
- Triantaphyllou, A.C. & McCabe, E. (1989). Efficient preservation of root-knot and cyst nematodes in liquid nitrogen. *Journal of Nematology*, Vol. 21, pp. (423-426).
- Trounson, A. & Mohr, L. (1983). Human pregnancy following cryopreservation, thawing and transfer of an eight-cell embryo. *Nature*, Vol. 305, pp. (707-709).
- Tsang, W.H. & Chow, K.L. (2009). Mouse embryo cryopreservation utilizing a novel high-capacity vitrification spatula. *BioTechniques*, Vol. 46, pp. (550-552).
- Tsang, W.H. & Chow, K.L. (2010). Cryopreservation of mammalian embryos: Advancement of putting life on hold. *Birth Defects Research. Part C, Embryo Today : Reviews*, Vol. 90, pp. (163-175).
- Vajta, G., Holm, P., Kuwayama, M., Booth, P.J., Jacobsen, H., Greve, T. & Callesen, H. (1998). Open pulled straw (OPS) vitrification: A new way to reduce cryoinjuries of bovine ova and embryos. *Molecular Reproduction and Development*, Vol. 51, pp. (53-58).
- Valdez, D.M., Jr, Miyamoto, A., Hara, T., Edashige, K. & Kasai, M. (2005). Sensitivity to chilling of medaka (*Oryzias latipes*) embryos at various developmental stages. *Theriogenology*, Vol. 64, pp. (112-122).

- Valencia, M.D., Miller, L.H. & Mazur, P. (1996). Permeabilization of eggs of the malaria mosquito *Anopheles gambiae*. *Cryobiology*, Vol. 33, pp. (149-162).
- Van Wyk, J.A., Gerber, H.M. & Van Aardt, W.P. (1977). Cryopreservation of the infective larvae of the common nematodes of ruminants. *The Onderstepoort Journal of Veterinary Research*, Vol. 44, pp. (173-194).
- Vanderzwalmen, P., Bertin, G., Debauche, C., Standaert, V., Bollen, N., van Roosendaal, E., Vandervorst, M., Schoysman, R. & Zech, N. (2003). Vitrification of human blastocysts with the hemi-straw carrier: Application of assisted hatching after thawing. *Human Reproduction*, Vol. 18, pp. (1504-1511).
- Wang, X. & Grewal, P.S. (2002). Rapid genetic deterioration of environmental tolerance and reproductive potential of an entomopathogenic nematode during laboratory maintenance. *Biological Control*, Vol. 23, pp. (78).
- Wang, R.Y., Guan, M., Rawson, D.M. & Zhang, T. (2008). Ultrasound enhanced methanol penetration of zebrafish (*Danio rerio*) embryos measured by permittivity changes using impedance spectroscopy. *European Biophysics Journal*, Vol. 37, pp. (1039-1044).
- Weigmann, K., Klapper, R., Strasser, T., Rickert, C., Technau, G., Jackle, H., Janning, W. & Klambt, C. (2003). FlyMove--a new way to look at development of *Drosophila*. *Trends in Genetics*, Vol. 19, pp. (310-311).
- Wheeler, M.B. (2003). Production of transgenic livestock: Promise fulfilled. *Journal of Animal Science*, Vol. 81 Suppl 3, pp. (32-37).
- Whittingham, D.G., Leibo, S.P. & Mazur, P. (1972). Survival of mouse embryos frozen to -196 degrees and -269 degrees C. *Science*, Vol. 178, pp. (411-414).
- Willadsen, S.M. (1977). Factors affecting the survival of sheep embryos during-freezing and thawing. *Ciba Foundation Symposium*, Vol. (52), pp. (175-201).
- Wilmot, I. & Rowson, L.E. (1973). Experiments on the low-temperature preservation of cow embryos. *The Veterinary Record*, Vol. 92, pp. (686-690).
- Wilton, L.J., Shaw, J.M. & Trounson, A.O. (1989). Successful single-cell biopsy and cryopreservation of preimplantation mouse embryos. *Fertility and Sterility*, Vol. 51, pp. (513-517).
- Yoshida, T., Arii, Y., Hino, K., Sawatani, I., Tanaka, M., Takahashi, R., Bando, T., Mukai, K. & Fukuo, K. (2011). High hatching rates after cryopreservation of hydrated cysts of the brine shrimp *A. franciscana*. *CryoLetters*, Vol. 32, pp. (206-215).
- Zeilmaker, G.H., Alberda, A.T., van Gent, I., Rijkmans, C.M. & Drogendijk, A.C. (1984). Two pregnancies following transfer of intact frozen-thawed embryos. *Fertility and Sterility*, Vol. 42, pp. (293-296).
- Zelenin, A.V., Alimov, A.A., Barmintzev, V.A., Beniumov, A.O., Zelenina, I.A., Krasnov, A.M. & Kolesnikov, V.A. (1991). The delivery of foreign genes into fertilized fish eggs using high-velocity microprojectiles. *FEBS Letters*, Vol. 287, pp. (118-120).
- Zernicka-Goetz, M., Pines, J., McLean Hunter, S., Dixon, J.P., Siemering, K.R., Haseloff, J. & Evans, M.J. (1997). Following cell fate in the living mouse embryo. *Development*, Vol. 124, pp. (1133-1137).
- Zhang, T. & Rawson, D.M. (1998). Permeability of dechorionated one-cell and six-somite stage zebrafish (*Brachydanio rerio*) embryos to water and methanol. *Cryobiology*, Vol. 37, pp. (13-21).

Zhang, X., Trokoudes, K.M. & Pavlides, C. (2009). Vitrification of biopsied embryos at cleavage, morula and blastocyst stage. *Reproductive Biomedicine Online*, Vol. 19, pp. (526-531).

## **Part 5**

# **Cryopreservation of Wildlife Genome (Terrestrial Animals)**





# Genome Banking for Vertebrates Wildlife Conservation

Joseph Saragusty  
Department of Reproduction Management,  
Leibniz Institute for Zoo and Wildlife Research, Berlin  
Germany

## 1. Introduction

About 140 years ago, Charles Darwin wrote in his book *The Descent of Man, and Selection in Relation to Sex* the following prediction: “The slowest breeder of all known animals, namely the elephant, would in a few thousand years stock the whole world.” (Darwin, 1871). Unfortunately, primarily due to human activities, this prediction will probably not come true. Sadly, not only elephants face the risk of extinction. The number of species listed as endangered is on the rise. The Species Survival Commission (SSC) of the International Union for Conservation of Nature and Natural Resources (IUCN) continuously monitors the planet’s fauna and flora and launches the IUCN Red List of Threatened Species (<http://www.iucnredlist.org>). As of the end of 2010, there were 5491 species of mammals described (IUCN, 2010). Of these, 1,131 species (21%) are now listed as endangered to some degree. In addition, there are 324 species listed as near threatened and another 836 species for which data is deficient and thus could be at risk. Adding all these numbers together, about 42% of the planet’s mammalian species are at some level of threat for extinction. The list also reports on 76 species (1.4%) of mammals that became extinct in recent years and two more species that are extinct in the wild and whose survival completely depend on *ex situ* breeding programs. The situation is not distinctively different in other classes of the vertebrata subphylum or in the other subphyla of the animal kingdom. If anything, it is even worse for some such as the reptiles (21% endangered), amphibians (30%), fish (21%) or among the invertebrates: insects (22%), mollusks (41%), crustaceans (28%), anthozoa (corals and sea anemones; 27%) or arachnids (58%). With each extinct species, the stability of the entire ecological system surrounding it and the food chain of which it is an integral part is shaken. Such shaking may lead to the co-extinction of dependent species (Koh et al., 2004).

In 1992 the Convention on Biological Diversity (CBD) was ratified at the United Nations Conference on Environment and Development in Rio de Janeiro. Ten years later, during the 6<sup>th</sup> meeting of the Conference of the Parties to the CBD in 2002, it was agreed “to achieve by 2010 a significant reduction of the current rate of biodiversity loss at global, regional and national level as a contribution to poverty alleviation and to the benefit of all life on Earth” (Convention on Biological Diversity, 2002). However, 2010, which was named by the United Nations as the “Year of Biodiversity”, has arrived and gone and this target not only has not

been met, even some of the indicators needed to measure progress (or regress) have not yet been developed or fully implemented (Walpole et al., 2009).

Based on paleontological data, of the total biota of about 10 million species, the natural or background extinction rate is approximately 1 to 10 species per year (Reid & Miller, 1989). This may be divided into species with restricted ranges for which extinction rate might be higher and those with widespread ranges for which it is considerably lower (Pimm et al., 1995). The expected extinction rate amongst all bird and mammal species is about one species every 100 to 1,000 years, yet the current extinction rate for these and other groups is about one species per year, which is 100 to 1,000 times the natural rate by some estimates (Reid & Miller, 1989; Pimm et al., 1995; Ceballos & Ehrlich, 2002; IUCN, 2004; Living Planet Report, 2008) and even as high as 10,000 times by others (Mace et al., 2005). One of the major problems behind these predictions is that we do not really know how many species are there and this is primarily true for many understudied taxonomic groups (e.g. bacteria, marine invertebrates, insects) and endemic species in many parts of the world, which by them being endemic to limited habitats face much higher risk of extinction (Pimm et al., 1995; Hunter, 2011). Earth history has witnessed 5 major events of mass extinctions in which a significant fraction of the diversity in a wide range of taxa went extinct within relatively short period (Erwin, 2001). The last, and probably the most well known episode, took place during the late Cretaceous era, approximately 65 million years ago, when the dinosaurs became extinct. The current dramatically accelerated rate of species extinction has been likened to these events and was termed 'the sixth mass extinction event in the history of life on Earth' (Chapin et al., 2000; Wake & Vredenburg, 2008). Various studies have demonstrated the severity of this accelerated extinction process on both the population level (Ceballos & Ehrlich, 2002) and the global biodiversity level (Living Planet Report, 2008; Rockstrom et al., 2009). Not all researchers agree with the definition of mass extinction (Barnosky et al., 2011) but all agree that the current extinction rate is far too fast. Whether we call it mass extinction or not, the cause for the current accelerated extinction rate is anthropogenic in essence, resulting from six major human interference categories: (i) habitat loss or fragmentation, (ii) over exploitation, (iii) species introduction (exotic species and diseases), (iv) pollution of water, soil and air, (v) global warming, and (vi) increasing atmospheric carbon dioxide level and the consequential acidification of the oceans. Based on different projections such as climate change, human population growth or deforestation rate, predictions suggest that large chunks of the world's biodiversity is destined to disappear (Reid & Miller, 1989; Ehrlich & Wilson, 1991; Thomas et al., 2004). For the sake of the entire ecosystem stability and for our and future generations' well being, and because we are the leading driver behind this accelerated decline in biodiversity, it is our obligation to try and slow down the current extinction rate. This, however, is not going to happen overnight, probably not even over a single generation time. So as to "buy time", the establishment of genome resource banks (GRB), which will store and manage collections of gametes (sperm and oocytes), embryos, tissues and organs of endangered species, has been proposed (Veprintsev & Rott, 1979; Benirschke, 1984; Wildt, 1992). By gathering such collections, at the moment primarily through cryopreservation, these institutions, among other services, fulfill their function as a mean to extend the reproductive lifespan of individuals beyond their biological life and prevent the loss of valuable individuals to the gene pool. Several such GRBs are already in existence. These include for example the

Frozen Ark Consortium (<http://www.frozenark.org/>; Clarke, 2009), the Amphibian Ark (<http://www.amphibianark.org/>) and the Biological Resource Bank of Southern Africa's Wildlife (Bartels & Kotze, 2006). Long-term preservation of such biological material is almost entirely a matter of how water therein is dealt with. Plant seeds, whose water content is very low, can easily be preserved at relatively high subzero temperatures of  $-20^{\circ}\text{C}$  to  $-30^{\circ}\text{C}$  (Ruttimann, 2006) whereas water content in animal tissues and cells is generally very high, in the range of 80%, thus requiring special handling.

About 70 years ago, the late Ernst W. Mayr coined one of the currently leading definitions for a species: "Species are groups of actually or potentially interbreeding natural populations, which are reproductively isolated from other such groups" (de Queiroz, 2005). The uniqueness of reproduction is thus central to the definition of species. It is therefore only natural that we find a wide variety of unique reproductive traits across species. These variations can come in a range of different forms, be it the anatomy of the genital system, morphology of gametes, presence or absence of accessory glands, mechanisms of ovulation, variations in the active hormones, duration of reproductive cycle and gestation and many other aspects of reproductive biology. It is also not surprising that great differences between species are found when it comes to the reaction of their gametes, embryos and tissues to the process of cryopreservation. Thus, when a successful cryopreservation protocol has been devised for a certain species, it will not necessarily be successful in other members of the same family, not to mention species that are phylogenetically further apart. In addition, to date the process of cryopreservation and the mechanisms that cause chilling- and cryodamages are not fully understood. Each new species we approach is thus a *terra incognita* and should be thoroughly studied before a successful protocol can be developed, if at all. Model species are often used for the development of basic techniques but in the end vast experimentation should be conducted in the target species. While this is relatively simple in domestic and laboratory animals, when a rare and endangered species is the target, opportunities to obtain gametes and other relevant cells and tissues are rare and far apart in terms of time and space, making progress extremely slow or practically impossible.

## 2. The male

The male's gametes are produced in very large numbers and are relatively easy to obtain. A wide variety of collection methods have been devised, including: 1) post-coital vaginal collection, either directly (e.g. O'Brien & Roth, 2000) or with the aid of intra-vaginal condom or vaginal sponge (e.g. Bravo et al., 2000), 2) artificial vagina (e.g. Gastal et al., 1996; Asher et al., 2000), 3) manual stimulation of either the rectum (e.g. Schmitt & Hildebrandt, 1998; Schmitt & Hildebrandt, 2000), the abdomen (Burrows & Quinn, 1937), or through stimulation of the penis (e.g. Schneiders et al., 2004; Melville et al., 2008), 4) electroejaculation (e.g. Hermes et al., 2009b), 5) pharmacologically-induced ejaculation by oral imipramine and intravenous xylazine (McDonnell, 2001) or through urethral catheterization after medetomidine administration (Zambelli et al., 2008), 6) aspiration from the cauda epididymis (e.g. Moghadam et al., 2005), and 7) semen retrieval from the cauda epididymis and proximal portion of the vas deference following castration or post mortem (e.g. Jewgenow et al., 1997; Saragusty et al., 2006; Keeley et al., 2011). Whereas techniques one to three above are relatively close to natural ejaculation, they require easy access to the

animal and excessive training (e.g. Robeck & O'Brien, 2004) and are thus limited to only a handful of species and individuals. The pharmacological techniques (5) and aspiration from the epididymis (6) are too invasive to be frequently used, and extraction from the epididymis (7) is a one-time technique, which is often used as a gamete rescue procedure. Epididymal sperm extraction and preservation is a well-documented collection technique. Probably the main advantage of this method is that it enables us to collect sperm post mortem and, if stored, it can be used to extend the reproductive "life span" of that individual. When dealing with endangered species, this may enable us to preserve the spermatozoa of wild and genetically valuable captive males who die in an accident or otherwise. The spermatozoa accumulated in the cauda epididymis is already mature and fertile (Foote, 2000) making it a useful source. Several methods were described as to how to extract the sperm out of the cauda epididymis. These include squeezing the cauda epididymis (Krzywinski, 1981), making cuts in the cauda epididymis (Krzywinski, 1981; Hishinuma et al., 2003; Martinez-Pastor et al., 2006; Saragusty et al., 2006), cutting and squeezing (Quinn & White, 1967), extrusion by air pressure (Kikuchi et al., 1998; Ikeda et al., 2002) and flushing the vas deferens (Martinez-Pastor et al., 2006). Flushing the vas deferens, when compared with the cutting method (Martinez-Pastor et al., 2006), was showed to be superior, yet it seems to be less suitable for field work. For epididymal sperm extraction, spermatozoa stored chilled within the epididymis seem to survive better and for longer periods than those stored in an extender (Ringleb et al., 2011). Still, for *in vivo* sperm collection, electroejaculation became by far the most frequently used method in wildlife species. To be successful, one would need a suitable probe, which often needs to be specifically designed for the animal to be collected based on preliminary knowledge of its anatomy (Hildebrandt et al., 2000; Roth et al., 2005). Even so, ejaculates often come with urine contamination (e.g. Anel et al., 2008) or they may come with or without the relevant secretions from all accessory glands. In elephants this is manifested by occasional ejaculates with very sticky consistency indicating that high level of secretions from the bulbourethral gland are present (personal observation) whereas in rhinoceros it is manifested by high viscosity of the ejaculate (Behr et al., 2009b). In rhinoceros, measuring alkaline phosphatase in the ejaculate was suggested as a mean to identify true ejaculates (Roth et al., 2010). Despite its wide use and success in many species, there is one major drawback to electroejaculation that limits its use on a frequent basis. To conduct electroejaculation, the animal needs to be anesthetized, something many zoos would rather avoid when possible. The need to anesthetize the animal makes it impossible to collect from the same individual on a regular, frequent basis. Anesthesia may also affect the collection procedure (Santiago-Moreno et al., 2010) and the quality of the collected sample (Campion et al., 2011). One should also keep in mind that the collection technique itself may effect the composition of the ejaculate and therefore its quality (Christensen et al., 2011). Thus, the development of preservation protocols for wildlife species progress slowly and often rely on relatively small number of individuals, repeats, and/or ejaculates.

Sperm evaluation also requires understanding of the species under study as sperm competition, for instance, is a major driver behind the wide variety of sperm traits, morphologies and behaviors found in nature (Tourmente et al., 2011). In primates, semen can be as thick as paste, which requires liquefaction and extraction of the cells into a diluent (e.g. Oliveira et al., 2010). In camelids, possibly due to the absence of vesicular glands,

sperm is also fairly viscous but it can be enzymatically liquefied (Bravo et al., 2000). Similar enzymatic liquefaction was also helpful when attempting to separate rhinoceros sperm from the seminal plasma, something that cannot be done efficiently with centrifugation alone in some of the ejaculates (Behr et al., 2009b). The volume and concentration also vary by several orders of magnitude among species. In the naked mole rat (*Heterocephalus glaber*) only 5 to 10  $\mu\text{L}$  of sperm can be collected with cells in the hundreds to thousands at the most, many of which are morphologically abnormal (unpublished data). In the European brown hare (*Lepus europaeus*) or the Asiatic black bear (*Ursus thibetanus*), volume of semen collected by electroejaculation is often in the range of 1 mL or less with concentrations that at times can exceed  $10^9$  cells/mL (personal observations; Chen et al., 2007). Low volume of up to a few mL and low concentration of few millions per mL is often the case in felids both in captivity and in the wild (Barone et al., 1994; Morato et al., 2001). In the pygmy hippopotamus (*Choeropsis liberiensis*) the sperm-rich fraction can be extremely concentrated. In one case we found as much as  $9.85 \times 10^9$  spermatozoa per mL (Saragusty et al., 2010a). In some other animals volumes can be very large. In boar, donkey or elephant semen can exceed 100 mL with concentrations of several hundred million cells per mL (unpublished data and e.g. Saragusty et al., 2009e; Contri et al., 2010). Initial motility is expected to be low in sperm collected from the epididymis, as epididymal sperm is immotile in most mammals. This is likely to change after a short incubation time in a suitable media. As many of the cells in the epididymis did not complete their maturation process at the time of extraction, cytoplasmic droplets can be highly prevalent (Saragusty et al., 2010b). Some specific characteristics were also noted in certain species. For example the seminal plasma pH of the black flying fox (*Pteropus alecto*) or the snow leopard (*Panthera uncial*) is high (8.2 and 8.4, respectively) (Roth et al., 1996; Melville et al., 2008) or in the Asian elephant (*Elephas maximus*) osmolarity of the seminal plasma is low, at around 270 mOsm/kg (Saragusty et al., 2009e). Such characteristics demonstrate the need to verify multiple aspects of the semen so that suitable diluents can be made. One should always keep in mind that when dealing with endangered species, many were pushed into a bottleneck situation, resulting in highly inbred populations. Inbreeding comes with a very high price with respect to the soundness of the reproductive system. This can be manifested in sperm quality (Roldan et al., 1998; Gomendio et al., 2000; Ruiz-Lopez et al., 2010) and in the outcome in term of litter size and survival (Rabon & Waddell, 2010). Once proper sample of sufficiently good quality is in hand, there are several options for its preservation.

## 2.1 Semen freezing

Probably the most popular preservation technique is slow freezing of semen or the cells therein. Spermatozoa are generally small in size and thus have low surface to volume ratio, an important factor in cryopreservation, which influences the movement of cryoprotectants and water in and out of the cells. They also have highly condensed and thus stable nucleus and little cytoplasm, making them relatively easy to freeze. Although problems are still numerous and even after more than 60 years of extensive research, propelled primarily by that related to human infertility and livestock and laboratory animal production, our knowledge about the exact mechanisms that eventually lead to success, failure or anywhere in-between is still very limited (Saragusty et al., 2009a). Thus, much of the progress in this field has been primarily empirical in nature (e.g. Saragusty et al., 2009e). Evolution made

each species unique in many respects, one of which is the sperm that comes in different shapes, sizes, membrane composition, and sensitivity to chilling, osmotic pressure, pH and more. This means that any new species is an enigma and the specific characteristics of its spermatozoa and seminal plasma and their interaction with various components of freezing extenders and stages of the freezing and thawing process should all be verified. While this can be done relatively easy in domestic and laboratory animals where samples are ample and easy to get, conducting such studies in endangered species is very difficult. Opportunities to obtain samples are rare and often far apart in terms of time and space. Such samples are thus very valuable and using them for experiments rather than for banking would be a waste of important genetic material. Still, to date, semen from probably upward of 200 species from all five major classes of the Vertebrata subphylum (mammals, birds, fish, reptiles and amphibians) have been cryopreserved. When approaching a new species, several hurdles must be overcome before a successful cryopreservation protocol can be developed. The first step is to determine the specific characteristics of its spermatozoa and seminal plasma mentioned above. The next step would be to determine the composition of the freezing extender. Sensitivity to chilling-, freezing- and thawing-associated damages and cryoprotectant-associated toxic or osmotic damages is species-specific and often even individual-specific (Thurston et al., 2002). Similarly, sensitivity to various aspects of sperm handling in preparation for cryopreservation should also be taken into account. In some species it is better to remove the seminal plasma by centrifugation before freezing [e.g. goat, boar, elephant (Saragusty et al., 2009e; unpublished data)] while in others this is not required [e.g. hare or cattle (Hildebrandt et al., 2009; Saragusty et al., 2009c)]. When the seminal plasma is removed, at times adding at least some back after thawing is needed to facilitate fertilization [e.g. camels (Pan et al., 2001)]. Centrifugation is also used for selection of live, morphologically normal cells. When doing so, one needs to understand the basic species-specific sperm characteristics. For example, in opossum (*Monodelphis domestica*) sperm tend to team into pairs to enhance swimming speed (Moore & Taggart, 1995) or in deer mice (genus *Peromyscus*) sperm form large aggregates (Fisher & Hoekstra, 2010). One should also keep in mind that the fast forward moving population is not necessarily the right one to choose because in some species the slow and steady ones are the cells to eventually win the race (Dziminski et al., 2009). Some species are highly sensitive to glycerol (e.g. mice, boar) while others require concentrations as high as 28% for freezing to be successful, with even higher concentrations to maintain high DNA integrity (e.g. in marsupials: Johnston et al., 1993; Czarny et al., 2009a). In some cases insemination can be done with the thawed sample [e.g. cattle, rhinoceros (Hermes et al., 2009b)] while in others the glycerol should be removed or else fertilization does not occur (e.g. Poitou donkey: Trimeche et al., 1998). So, on the way to developing a successful cryopreservation protocol, species-specific characteristics should be identified and techniques to protect the cells from all these damaging mechanisms should be devised (Zeron et al., 2002; Saragusty et al., 2005; Pribenszky et al., 2006; Saragusty et al., 2009b; Pribenszky & Vajta, 2010). Several cryopreservation techniques were described. These can be divided into field-friendly and -unfriendly ones. The field-friendly techniques include the pellet method [placing a sample drop of ~200  $\mu$ L directly on carbon dioxide ice ("dry ice")] (Gibson & Graham, 1969), the dry-shipping container technique (Roth et al., 1999), freezing in cold ethanol (Saroff & Mixner, 1955) or in liquid nitrogen vapor (Sherman, 1963; Roussel et al., 1964). The last two

being a bit less field-friendly as they require bringing the cold ethanol or liquid nitrogen to the site of work. Still, freezing in liquid nitrogen vapor is currently the most popular one amongst the low-tech, equipment-free freezing techniques. The more sophisticated and more laboratory-bound techniques include the controlled-rate freezing machines (Landa & Almquist, 1979) and the directional freezing machine (Arav, 1999; O'Brien & Robeck, 2006; Si et al., 2006; Saragusty et al., 2007; Reid et al., 2009). When the initial sample is of very poor quality or with very small number of cells, small cell-number or single cell cryopreservation techniques may become useful. Starting in the late 1990's (Cohen & Garrisi, 1997; Cohen et al., 1997), reports on several single sperm cryopreservation techniques showed up in the scientific literature (Walmsley et al., 1998; Gil-Salom et al., 2000; Gvakharia & Adamson, 2001; Just et al., 2004; Herrler et al., 2006; Isaev et al., 2007; Koscinski et al., 2007; Woods et al., 2010). Using these various techniques, researchers reported a wide range of outcomes and recovery efficiency. Time will tell which of these technologies, or others that are currently under development, will emerge as the leading technique that will gain a foothold in sperm banks. Naturally, when sperm banking is considered, single sperm cryopreservation is an option to be considered only if all other possibilities were exhausted. When banking sperm from wildlife, the aim is to bank large number of cells from large number of individuals to ensure availability and variability.

About three decades ago, the thus far only technique that has reached commercial level made it possible to sort sperm according to the sex chromosome they carry (Johnson et al., 1987a; Johnson et al., 1987b). This technique has been tested in various wildlife species such as elephants, rhinoceros, dolphins and non-human primates (O'Brien et al., 2004; O'Brien & Robeck, 2006; Behr et al., 2009a; Behr et al., 2009b; Hermes et al., 2009a). Sperm sorting machines, however, are very expensive, scarce and usually situated far away from where the sperm donor and recipient are located. For this, the double freezing technique has been developed (Arav et al., 2002; Hollinshead et al., 2004; Maxwell et al., 2007; Saragusty et al., 2009c; Montano et al., 2010). This technique allows collection and cryopreservation of sperm sample near the donor, transportation of the frozen sample to the sorting center, thawing it for sorting and then freezing the sorted sample for transportation to the recipient. In this respect the advantage of large volume freezing at the sperm donor site is clear.

Although advances were made over the six decades of sperm cryopreservation history, the basic model that will predict behavior of spermatozoa during cryopreservation is still to be devised. Current knowledge is lacking in many respects and thus, when approaching a new species, much empirical work, often based on trial and error, should be conducted. Thanks to the large number of cells in each ejaculate, these can be split into several treatment modalities, thus speeding up the freezing protocol development process. Once better understanding is attained, and predictions can be made for sperm behavior under various freezing-associated conditions, probably the right course to be taken will be tailor-made, individual-based cryopreservation. This will help overcoming considerable differences between males in response to cryopreservation (Thurston et al., 2002; Saragusty et al., 2007; Loomis & Graham, 2008). However, despite all hurdles, and certainly since ICSI made sperm motility and membrane integrity obsolete, sperm banking under liquid nitrogen is probably the most widely used technique in gametes and tissue banking for reproduction preservation. Success in post-thaw survival, and often also in offspring production, has been

demonstrated in many vertebrate species. And yet, there are other options to preserve male fertility.

## 2.2 Semen vitrification

Ice crystals, both outside and even more so – inside, can be very damaging to any frozen cell or tissue. To avoid ice formation and to minimize the pre-freezing chilling damages, vitrification can be used. Vitrification, also known as ice-free cryopreservation, is a process in which liquid is transformed into an amorphous, glass-like solid, free of any crystalline structures (Luyet, 1937). A major advantage of vitrification over slow freezing is its low-tech, low cost, simple to use, suitable for the field character. For vitrification to be successful, however, much experience in sample handling before cooling and after warming and in loading the sample into or onto the carrier system, are needed. Probability of vitrification depends on the interaction between three factors – cooling rate, sample volume and its viscosity, according to the following general relationships (Saragusty & Arav, 2011):

$$\text{Probability of Vitrification} = \frac{\text{Cooling rate} \times \text{Viscosity}}{\text{Volume}} \quad (1)$$

Thus, to achieve the state of vitrification, very high viscosity (usually attained through high concentrations of cryoprotectants or low water content), and/or very high cooling rates and/or very small volumes are needed. Since the high cryoprotectant concentrations needed are beyond what spermatozoa from most species can tolerate, the vitrified volume is usually being considerably reduced and techniques to achieve high cooling rate with adequate heat transfer throughout the sample are devised. For example, using the cryo-loop vitrification technique, it was calculated that cooling rate as high as 720,000°C/min has been achieved (Isachenko et al., 2004) or with quartz capillaries, cooling rates of around 250,000°C/min were reported (Risco et al., 2007; Lee et al., 2010). The technique, though, have several major drawbacks when sperm banking is considered: 1) The small volume that can be vitrified (at best, presently only a few microliters of semen suspended in vitrification solution) is way too small for banking for species conservation purposes and vitrifying large number of samples from each individual is not practical. 2) The small volume, and thus the small sperm number, make vitrified samples impractical for use in artificial insemination or even in standard IVF. Its optimal utilization is through ICSI, a technique that requires specialized equipment and expertise not available in most laboratories dealing with wildlife, and ICSI has not yet been developed for most species. 3) The risk of contamination through the liquid nitrogen prevails in many of the currently available vitrification carrier devices, which are open systems. 4) High permeable cryoprotectant concentrations (up to 50% compared to 3-7% in slow freezing in most species) are still needed in many of the vitrification protocols despite the reduction in volume. Such concentrations are both toxic and cause osmotic damages to the cells. To overcome this, permeating cryoprotectant-free vitrification techniques were developed through a sizable increase in cooling rate (Nawroth et al., 2002; Isachenko et al., 2003; Merino et al., 2011). Sperm vitrified this way can maintain motility (Isachenko et al., 2004) and resulted recently in human live birth (Sanchez et al., 2011).



### 2.3 Sperm drying

Storage of cryopreserved samples under liquid nitrogen is very demanding in terms of maintenance, storage space, storage equipment, specially trained personnel and associated costs. Resulting from the need for constant liquid nitrogen supply in large quantities, such storage facilities have very high carbon footprint. The possibility of discontinuation of the liquid nitrogen supply due to human (e.g. conflict, strike) or natural (e.g. earthquake, hurricane) put these facilities at a constant risk. An alternative that would minimize all these is the dry storage. Drying of cells can be done by either freeze-drying or convective-drying. Freeze-drying is achieved by sublimation of the ice after freezing the sample to subzero temperatures. Convective drying, on the other hand, is achieved by placing the sample in a vacuum oven at ambient temperatures. Sperm drying is, however, damaging to cellular membrane and rehydrated cells are often devoid of biological activity, motility and viability. Some degree of chromosomal damage may also take place due to endogenous nucleases. Attempts to freeze-dry spermatozoa were first reported about six decades ago on animal (Polge et al., 1949; Sherman, 1957; Yushchenko, 1957; Meryman & Kafig, 1959) and human (Sherman, 1954) sperm. Most researchers, however, consider all these early reports, dubious. The definitive proof that freeze-dried spermatozoa retain genetic integrity was established only when microsurgical procedures for bypassing the lack of motility of freeze-dried spermatozoa were developed, and normal mice were produced by intracytoplasmic sperm injection (ICSI) of freeze-dried sperm (Wakayama & Yanagimachi, 1998). To date, embryonic development after ICSI with freeze-dried sperm heads has been reported in humans (Katayose et al., 1992; Kusakabe et al., 2008), hamster (Katayose et al., 1992), cattle (Keskin-tepe et al., 2002; Martins et al., 2007), pigs (Kwon et al., 2004), rhesus macaque (Sanchez-Partida et al., 2008), cats (Moisan et al., 2005; Ringleb et al., 2011) and fish (Poleo et al., 2005), and live offspring were reported in mice (Wakayama & Yanagimachi, 1998; Kaneko et al., 2003; Ward et al., 2003), rabbits (Yushchenko, 1957; Liu et al., 2004), rat (Hirabayashi et al., 2005; Hochi et al., 2008), fish (Poleo et al., 2005) and horses (Choi et al., 2011). Storage at room temperature would be ideal, and at least for mid-range duration it appear to be fine (3 years storage of somatic cells; Loi et al., 2008a). High-temperature storage, however, might be damaging to DNA integrity according to some (Kaneko & Nakagata, 2005; Hochi et al., 2008) but not all (Li et al., 2007; Klooster et al., 2011) researchers. These differences may be due to differences in the drying technique or related to differences between species (Li et al., 2007; Klooster et al., 2011; Kusakabe & Tateno, 2011).

While there are many reports on freeze-drying of sperm and other relevant cells, those on convective drying are scarce. Some researchers, however, consider convective drying to be the better option for the fact that it does not involve the freezing step, thus avoiding freezing-associated damages. This technique has been used to dry fibroblasts, and spermatogonial and hematopoietic stem cells (Katkov et al., 2006; Meyers, 2006).

Regardless of the drying process used, for now sperm drying will usually be placed way behind sperm freezing or vitrification because of the loss of motility and viability, and the need for ICSI. Thus, sperm drying is still to be demonstrated in true wildlife species.

### 2.4 Liquid phase semen short- to mid-term storage

In many cases, sperm can be collected in the field, away from any fully equipped andrology and cryobiology laboratory or a source for liquid nitrogen, and transferring the samples to a

facility for processing may take time. For such cases, or when the sample is destined to be used but not immediately, short- and mid-term supra-zero preservation techniques may help. Nature regularly preserves sperm for months to years in a wide variety of species including members of all vertebrate classes (Holt & Lloyd, 2010; Holt, 2011). The location nature has elected is within the female's reproductive tract. This ability has been described in many species and has been investigated in a few. To date the mechanism has not been discovered although a possible direction has recently emerged. In the greater Asiatic yellow bat (*Scotophilus heathii*), with a regular gap of several months between mating and fertilization, it was shown recently that sperm storage is regulated by androgens (Roy & Krishna, 2011). Administration of flutamine, an androgen antagonist, resulted in loss of sperm storage ability in treated females. It was also suggested that sperm storage duration and survival is the outcome of interplay between expression of B-cell lymphoma 2 (Bcl-2) – an anti-apoptotic factor, and caspase-3 – a promoter of apoptosis. In the absence, as yet, of clear knowledge on how nature does it, *in vitro* techniques were devised in an attempt to achieve this long-term fresh storage goal. In some species, such as the pig, chilled storage is the most widespread method of preservation as thus far sperm cryopreservation has provided only mediocre post-thaw results. When planning on extended chilled storage, several sperm energy-metabolism aspects should be taken into consideration. Both glycolysis and the Krebs cycle play an important role in sperm energy metabolism. Sperm from various species stored in a range of solutions, osmolarities and storage temperatures, were shown to be functional when inject into oocytes after storage of weeks to several months (Kanno et al., 1998; Van Thuan et al., 2005; Riel et al., 2007; Riel et al., 2011). An alternative is to simply leave the spermatozoa inside the epididymides and keep these at 4°C. This epididymal preservation option was demonstrated to produce good results in dogs (Yu & Leibo, 2002), bovine (Martins et al., 2009), gazelles (Saragusty et al., 2006), ram (Tamayo-Canul et al., 2011) and many other species. Short-term epididymal preservation has many advantages when dealing with wildlife. Animals usually have the “tendency” to die at inconvenient time or location. The ability to preserve spermatozoa within the epididymis, till it is transported to a laboratory for processing, helps us buy time for rescue procedures. This can easily be done by non-experts (zoo or park employees for example) by simply cutting off the testicles, putting them in 0.9% saline and keeping them in the refrigerator. Motility preservation for several days can also be done with ejaculated sperm in egg yolk based extenders. For instance, we have recently showed that pygmy hippopotamus (*Choeropsis liberiensis*) spermatozoa preserved some motility for 3 weeks when suspended in the Berliner Cryomedium basic solution (a TEST-egg yolk based extender) (Saragusty et al., 2010a) or, in humans, sperm suspended in PBS supplemented with salts, BSA, antibiotics and glucose had about 15% motility and over 40% viability after 10 days at room temperature (Amaral et al., 2011). During such storage, the reduced metabolism and biological activity, the disintegration of dead cells or the presence of leukocytes in the suspension, all result in the release of reactive oxygen species (ROS) and other damaging components into the solution (Whittington & Ford, 1999). Removal of the leukocytes and periodic exchange of solution should thus be beneficial to the stored cells and extend their life.

## 2.5 Preservation of other male reproductive-related cells

Spermatozoa, however, can only be potentially retrieved from adult, relatively healthy, individuals but not from sick, azoospermic, or prepubertal ones, and often these carry valuable genetic material that, if not preserved, will be lost for the population. Thanks to

ICSI, even early developmental stages such as elongating or elongated spermatids can be utilized for fertilization. Such cells as testicular spermatozoa and earlier developmental stages can be extracted using testicular sperm extraction (TESE) techniques, and then used through ICSI to fertilize oocytes (Schoysman et al., 1993; Devroey et al., 1995; Kimura & Yanagimachi, 1995; Hewitson et al., 2002). These early-stage cells can be used fresh but they can also be cryopreserved and used at a later stage when needed (Hirabayashi et al., 2008).

Cells of even an earlier developmental stage than the spermatocytes and spermatids are the spermatogonium or spermatogonial stem cells, which can be collected from any male, including infants and juveniles. Infant mortality rate is known to be relatively high in many populations (e.g. Howell-Stephens et al., 2009; Saragusty et al., 2009d) so methods to preserve germ cells from valuable individuals in certainly called for. Spermatogonial stem cells transplantation was first reported in mice (Brinster & Zimmermann, 1994) when it was demonstrated that such transplantation can lead to spermatogenesis. The transplantation technique was later extended to other species such as pigs (Honaramooz et al., 2002), bovine (Izadyar et al., 2003), goats (Honaramooz et al., 2003a; Honaramooz et al., 2003b), cynomolgus monkeys (Schlatt et al., 2002a), and recently to felids as well (Silva et al., 2011). Xenogeneic transplantation, usually from other mammals to nude, immune-deficient mice, has also been reported. However, the further apart (phylogenetically) the donor and recipient species are, the more difficult it becomes. Using this technique, isolated donor testis cells are infused into the seminiferous tubules of the recipient whose testes have been depleted of all germ cells (by irradiation or chemotherapy). The spermatogonial stem cells establish themselves in the testis and through spermatogenesis, produce spermatozoa carrying the donor genetic material. In 2006 the proof that such xenotransplanted cells can actually produce normal, functioning spermatozoa was reported (Shinohara et al., 2006). In their study, spermatogonial stem cells collected from immature rats were transplanted into chemically sterilized mice and the spermatozoa or spermatids collected from the recipient mice produced normal, fertile rat offspring, both when freshly used and following cryopreservation. The donor stem cells can also be grown in culture to generate more cells for transplantation (Nagano et al., 1998) and they can be cryopreserved for future use (Avarbock et al., 1996). Under very complex *in vitro* culture conditions, and with very low efficiency, morphologically normal and even motile spermatozoa were generated from spermatogonial stem cells (Feng et al., 2002; Hong et al., 2004; Stukenborg et al., 2009).

## 2.6 Testicular tissue cryopreservation

Tissue cryopreservation is more complex than cellular preservation because tissue is composed of more than one cell type and thus of different water and cryoprotectant permeability coefficient values and different sensitivities to chilling and osmotic challenges. Tissue is also larger in volume and thus cryoprotectant penetration is difficult and heat transfer is not uniform, putting the center of the sample at greater risk of intracellular ice formation and death. This is true for testicular tissue, ovarian tissues and many other types of tissues and whole organs. Testicular tissue preservation can be done in one of three basic forms. The tissue can be cryopreserved for future use, it can be cultured *in vitro* for short to mid-term preservation or it can be transplanted. When preserved in the cryopreserved form, one can freeze the whole organ or even the entire animal. Recently it was demonstrated that

spermatozoa or spermatids retrieved from reproductive tissues (whole testes or epididymides) frozen for up to one year at  $-80^{\circ}\text{C}$  or from whole mice frozen at  $-20^{\circ}\text{C}$  for up to 15 years, can produce normal offspring when used, through ICSI, to fertilize mature oocytes (Ogonuki et al., 2006). This success followed a previous, failed, attempt to cryopreserve the entire testis (Yin et al., 2003). The other option is to cryopreserve testicular tissue slices. This technique is widely used today in both adult and pediatric human medicine as a mean to preserve fertility of patients undergoing cancer treatments. To cryopreserve the tissue, it is cut into tiny pieces, usually in the range of  $1\text{-}2\text{ mm}^3$  to ensure cryoprotectant penetration, efficient heat transfer and eventual successful grafting. Other alternatives that have been proposed are to mince the tissue and then suspend it in freezing extender to achieve better cryoprotection (Crabbe et al., 1999) or to cut the testicular tissue into thin stripes (e.g.  $\sim 9 \times 5 \times 1\text{ mm}$  in sheep) to increase the total number of seminiferous tubules in each graft (Rodriguez-Sosa et al., 2010). Although such tissue samples can be obtained from every individual, infant, juvenile or adult, almost all successful studies to date used immature tissue (Ehmcke & Schlatt, 2008). Like in semen cryopreservation, there are differences between species in the reaction of their testicular tissue to cryoprotectants, chilling and cryopreservation (Schlatt et al., 2002b). The preserved testicular tissue can be handled in several ways. From these tissues, spermatozoa, spermatocytes and round and elongated spermatids can all be retrieved and used to fertilize oocytes through ICSI (Hovatta et al., 1996; Gianaroli et al., 1999). Testicular tissue can also be transplanted back to the donating individual (autografting), to another individual of the same species (allografting) or to individual of a different species, usually to nude or immunodeficient mice (xenografting). After transplantation, the graft may be lost due to tissue rejection or ischemia. If it manages to survive the critical first few days, blood supply will reach the graft, it will be supported by the recipient system and, after some time, will start producing spermatozoa, which can be harvested by surgical excision of all or part of the graft (Schlatt et al., 2002b). Although dependent on the recipient system for support, the spermatogenesis cycle length is assumed to be inherent to the spermatogonial stem cells, which are expected to preserve the donating species spermatogenesis length (Zeng et al., 2006). However other studies showed that in some species, the process is accelerated when their testicular tissue was xenografted into mice (rhesus monkeys; Honaramooz et al., 2004) while in others it is not (domestic cat; Snedaker et al., 2004). Acceleration, when identified, bears special interest for species preservation as it can shorten generation time and thus speed up population growth. This acceleration, however, may also mean abnormal spermatogenesis process that produces abnormal gametes. The sperm produced this way does not go through epididymal maturation process so the only way it can be utilized is by ICSI (Shinohara et al., 2002). One should also keep in mind that it is very costly to keep immunodeficient mice and handle them under germ-free conditions and, of course, repeated transplantations from one mouse to another are required to maintain viable tissue for many years. Still, testicular tissue cryopreservation was done in several species and pregnancies were achieved in mice (Schlatt et al., 2002b; Shinohara et al., 2002), rabbit (Shinohara et al., 2002), human (Hovatta et al., 1996), Djungarian hamsters (Schlatt et al., 2002b) and marmoset monkeys (Schlatt et al., 2002b), to name a few. Testicular tissue can also be cultured *in vitro* to give rise to mature and competent cells. Culture conditions, however, are very complex and, until recently, attempts were encouraging but still unsuccessful (Gohbara et al., 2010). Earlier this year,

generation of offspring from such tissues was demonstrated (Sato et al., 2011). In that study, neonatal mouse testicular tissue cultured *in vitro* for over two months (with or without being previously cryopreserved), generated fully competent spermatids and spermatozoa, which led to embryonic development and healthy and reproductive-active offspring production. This exciting development still needs to be evaluated in terms of accuracy of the genetic profile and absence of aneuploidy in haploid cells (Cheung & Rennert, 2011) as well as its applicability to other species. However, the fact that healthy and fertile offspring were produced is very encouraging.

### 3. The female

In comparison to the male, females' gametes pose several difficulties when it comes to preservation (Table 1). Very small number of gametes is progressing to the more advanced developmental stages during each cycle, and at best only a handful mature and ovulate. When dealing with rare and endangered species in which the number of available individuals for research is extremely limited and often spatially and temporally far apart, progress is very slow and limited by the small numbers. Oocytes and embryos are orders of magnitude larger than spermatozoa, thus bringing down the ratio between surface area and volume. The outcome is slower movement of water and cryoprotectants across the cellular membrane and elevated risk for intracellular ice formation. Unlike in males, *in vivo* collection of oocytes, and to a lesser extent - embryos, is an invasive procedure requiring anesthesia or sedation. Although production of new oocytes exists even in adulthood (Niikura et al., 2009; Tilly et al., 2009), it is very minimal. So, in general terms, the female can be considered as if it is born with a limited life-long supply. Males on the other hand produce sperm continuously, throughout their adult life, sperm that can be collected relatively easy almost any time. All these differences contribute to the fact that while the number of species in which sperm was cryopreserved is in the hundreds, the number of species in which embryo cryopreservation was reported (not all successful) is currently less than 50 and the number of species in which oocyte cryopreservation was attempted is far less than that.

	Male	Female
Gamete size	<10 $\mu$ m (head)	10s-100s $\mu$ m (species specific)
Numbers	Millions to billions	Few at a time
Production	Continuous	Very limited new production
Accessibility	Easy to collect	Invasive procedure
Collection	Almost any time	In estrous (need monitoring)

Table 1. comparison between male and female gametes in relation to gamete cryopreservation.

Female gametes can be collected at different time points in their maturation process: 1) as mature oocytes, following ovulation (natural or chemically induced), 2) as mature and immature oocytes, by ovum pick up, either transabdominally, transvaginally or

transrectally. This can be done during natural estrus cycle or following chemical stimulation, 3) at all developmental stages, mostly immature, following ovariectomy, either when neutering the animal or post mortem, a possibility with time constraint because deterioration is fast *in vitro* and even faster *in vivo* - reasonable quality oocytes can be harvested only up to ~24h after the removal of the ovaries if they were held at 4°C (Wood et al., 1997; Cleary et al., 2001; Personal experience), 4) after fertilization (natural or by artificial insemination), as embryos. This can be done at any stage prior to implantation. The collected oocytes can be at any level of maturation including oocytes found in primordial, preantral or antral follicles, each presenting its own special requirements and sensitivities. Harvesting and preserving oocytes is almost pointless if all other associated assisted reproductive technologies - *in vitro* maturation, *in vitro* fertilization, *in vitro* culture and embryo transfer, are not mastered (at present or in the future) to support it. Female fertility preservation can be done through preservation of oocytes and/or embryos at various developmental stages, as well as by preservation of ovarian tissue or entire ovaries, all of which will be discussed in details in the following sections.

### 3.1 Oocyte cryopreservation

For decades it was believed that females are born with their life supply of oocytes in their ovaries, all dormant at a very early maturation stage (Zuckerman, 1951). This dogma, however, was recently challenged by a number of studies suggesting that the female gonads retain the ability to regenerate oocytes throughout adulthood, albeit at a very limited number (e.g. Niikura et al., 2009; and reviewed in Tilly et al., 2009). The vast majority of oocytes, however, is already in the ovaries at birth and remains dormant at a very early stage of maturation to adulthood and beyond. Once the female reaches puberty, one or more cohorts of oocytes are selected at each estrus cycle to progress in the maturation process and, depending on the species, one or several oocytes are ovulated. The remaining oocytes in these selected cohorts degenerate or luteinize to form accessory corpora lutea. To be fertilized, an oocyte needs to overcome the meiotic block and progress to the metaphase II (MII) stage of maturation or else only very few oocytes will fertilize (Luvoni & Pellizzari, 2000). Thus, an *in vitro* maturation procedure should be in hand to handle immature oocytes. This process is currently developed for only a handful of species and even for these success is often fairly limited (Krisher, 2004). Furthermore, collection of immature oocytes disrupts the natural maturation process and thus compromises the quality of the oocytes even if they are later matured *in vitro*. During oocyte maturation and follicular growth, the oocyte accumulates large quantities of mRNA and proteins needed for the continuation of meiosis, fertilization and embryonic development. In the absence of the entire supporting system in the *in vitro* culture, production of some of these needed components is hampered. The resulting mature oocytes are therefore of inferior quality when compared to *in vivo* matured oocytes. In seasonal animals, oocytes collected out of the season may show resistance to IVM and IVF (Spindler et al., 2000; Berg & Asher, 2003; Comizzoli et al., 2003). In red deer for example, while about 15% of cleaved oocytes collected during the season (April-July) developed *in vitro* to blastocysts, none have developed if collected after July (Berg & Asher, 2003). Comizzoli et al. (2003) showed that anti-oxidants and FSH in the culture media can overcome this problem in the domestic cat model they have studied. Naturally, *in vitro* fertilization and culture should also be developed so that embryos can be generated for transfer. During the development of such techniques, as well as in those cases when conspecific oocytes are not available, interspecific IVF can be considered. This was done, for example between the mouflon (*Ovis orientalis musimon*) and the domestic sheep

(Ptak et al., 2002) or between some small cat species and the domestic cat (Herrick et al., 2010) or even between a cat and a mouse (Xu et al., 2011). To enhance the number of oocytes collected at any ovum pick-up procedure, hormonal stimulation can be used. This, however, will result in both mature and immature oocytes and the quality of both may be compromised (Blondin et al., 1996; Moor et al., 1998; Takagi et al., 2001). Although to date no morphological or other method is able to accurately predict which oocytes have optimal developmental potential (Coticchio et al., 2004), it is clear that oocyte quality is a major determining factor in the success of IVF (Coticchio et al., 2004; Krisher, 2004; Combelles & Racowsky, 2005), early embryonic survival, the establishment and maintenance of pregnancy, fetal development, and even adult disease (reviewed in Krisher, 2004). Once all these hurdles have been overcome and while keeping in mind the importance of oocyte quality, the next major hurdle to overcome is oocyte cryopreservation.

Oocytes are very different from sperm or embryos with respect to cryopreservation. Oocytes (and embryos) are in the range of three to four orders of magnitude larger than spermatozoa, thus substantially increasing their surface-to-volume ratio and making them sensitive to chilling and susceptible to intracellular ice formation (Arav et al., 1996; Zeron et al., 1999; Chen & Yang, 2009). Oocytes at the MII stage also have a formed fuse that is chilling-sensitive (Chen & Yang, 2009) and their plasma membrane has low (temperature dependent) permeability coefficient, thus making the movement of cryoprotectants and water slower (Jackowski et al., 1980; Ruffing et al., 1993). This, however, may vary between species. Membrane permeability increases after fertilization (Jackowski et al., 1980) and seem to be higher in morula/blastocyst stages as compared to earlier embryonic stages (Jin et al., 2011), thus contributing to the fact that embryos are easier to cryopreserve. The oocyte cytoskeleton is highly sensitive to chilling and gets disorganized at suboptimal temperatures (Trounson & Kirby, 1989). Oocytes also have high cytoplasmic lipid content which increases chilling sensitivity (Ruffing et al., 1993). They have less submembranous actin microtubules (Gook et al., 1993) making their membrane less robust. The meiotic spindle, which has formed by the MII stage, is very sensitive to chilling and may be compromised as well (Ciotti et al., 2009) resulting in aneuploidy (Sathananthan et al., 1988) and oocytes are more susceptible to the damaging effects of reactive oxygen species (Gupta et al., 2010). Many of these parameters change after fertilization, making embryos less chilling sensitive and easier to cryopreserve (Jackowski et al., 1980; Gook et al., 1993; Fabbri et al., 2000). Despite many advances in the field of cryopreservation, oocyte (ovulated, mature or immature) cryopreservation still has a long way to go before it can be routinely utilized in many species. Even in human medicine, fewer than 200 births resulting from cryopreserved oocytes were reported as of 2007 (Edgar & Gook), a number that went up to around 500 by 2009 (Nagy et al.). Yet, despite all these difficulties, some success in oocyte cryopreservation has been reported.

Two main cryopreservation techniques are used for oocyte cryopreservation - slow (equilibrium) freezing and vitrification. In slow freezing, oocytes are exposed to permeating cryoprotectants in the range of 1.0-1.5 M and are frozen, following equilibration and seeding, at a rate of 0.3°C to 0.5°C per minute down to -30°C or lower. Once at the desired temperature they are plunged into liquid nitrogen to vitrify the intra- and extracellular still unfrozen compartments and for storage. Attempts to improve outcome by altering the components of the freezing extender (e.g. replacing sodium chloride with choline chloride; Stachecki et al., 1998a; Stachecki et al., 1998b; Quintans et al., 2002) suggest that there is still some room for improvements in the standard techniques widely in use. Vitrification usually exposes the oocytes to substantially higher concentration of cryoprotectants, in the range of

5.0 to 7.0 M, and cryopreservation is done at cooling rates of 2,500°C per minute or more, depending on the technique used. Vitrification can, however, be achieved even at cryoprotectant concentrations similar to those used for slow freezing if sample volume is small enough and/or cooling rate is high enough to achieve vitrification. One advantage of vitrification over slow freezing, when oocytes are concerned, is the higher survival rate that the fast cooling facilitates. To achieve very high cooling rates, a wide variety of carrier systems were developed (reviewed by Saragusty & Arav, 2011). The small-volume sample, with the carrier, is plunged directly into liquid nitrogen or nitrogen slush. For vitrification to be successful, one should be highly experienced in handling the oocytes throughout the dilution process and in loading them onto or into the carrier system. By cooling liquid nitrogen from its boiling temperature (-196°C) to close to its freezing temperature (-210°C), nitrogen slush is formed. Vitrification in slush gives at least two major advantages. When a sample is inserted into liquid nitrogen, the nitrogen boils and forms an insulation vapor layer around the sample (the Leidenfrost effect). Boiling is considerably reduced when slush is used. Slush also significantly increases the cooling rate. Several studies have demonstrated the superiority of slush over liquid nitrogen (Arav & Zeron, 1997; Isachenko et al., 2001; Beebe et al., 2005; Santos et al., 2006; Lee et al., 2007; Criado et al., 2010) but some found little or no difference (Martino et al., 1996; Cuello et al., 2004; Cai et al., 2005) (Table 2). When cooled at such high cooling rates, oocytes spend very short interval at their lipid phase transition temperature, thus avoiding, or at least minimizing, chilling injury (Arav et al., 1996). Vitrification also reduces the loss of mRNA from the cryopreserved oocytes (Chamayou et al., 2011), mRNA that is crucial for embryonic development and beyond.

The first human pregnancy from cryopreserved (by slow freezing), *in vitro* fertilized oocyte was reported in 1986 (Chen, 1986) following success in other (laboratory) species that came a few years earlier, such as mice (Whittingham, 1977) and rat (Kasai et al., 1979) oocytes cryopreserved to -196°C or mice oocytes frozen to -75°C (Parkening et al., 1976). Still, despite several decades of research and many advances in the field, success is very limited and oocyte cryopreservation is still labeled as experimental even in human medicine (Noyes et al., 2010). Cryopreservation can cause cytoskeleton disorganization (Trounson & Kirby, 1989), chromosome and DNA abnormalities (Van Blerkom, 1989), spindle disintegration (Pickering & Johnson, 1987), plasma membrane disruption (Van Blerkom, 1989) and premature cortical granule exocytosis with its related zona pellucida hardening, making it impermeable to spermatozoa (Johnson et al., 1988). It also hamper, at least to some extent, the ability of oocytes to mature *in vitro* after thawing/warming (Rao et al., 2011). When comparing these parameters, in addition to survival rate, oocyte cryopreservation by vitrification seem to be superior to slow freezing, which explains why oocyte vitrification is gradually replacing slow freezing as the leading technique of preservation. Either open or closed carrier systems are used for vitrification. The closed systems are more secure while the open systems can provide higher cooling rates by direct exposure of the sample to liquid nitrogen. The large number of carrier systems (see Saragusty & Arav, 2011 for a most current list) suggests that the field is still developing and even decision if the open or the closed system is better is still under debate. While in most carrier systems, the volume that enables vitrification limits the number of oocytes that can be contained in it to just a few, some carrier systems such as the electron microscope grid (Steponkus et al., 1990) or nylon mesh (Matsumoto et al., 2001) allow simultaneous vitrification of a large number (as many as 65 in one study) of oocytes. Most reports on oocyte vitrification are, however, sporadic in nature and usually on small number of oocytes. The open system [Cryotop and Open Pulled Straw (OPS)] was used to vitrify germinal vesicle-stage oocytes of the minke whale



(*Balaenoptera bonaerensis*) with the Cryotop producing better results in post-warming morphology and rate of maturation (Iwayama et al., 2005) and both carrier systems produced better results compared to an earlier attempt to cryopreserve minke whale oocytes by slow freezing (Asada et al., 2000). Oocytes of the Mexican gray wolf (*Canis lupus baileyi*) and the domestic dog were also vitrified recently using the Cryotop carrier system (Boutelle et al., 2011). Post warming viability was 61% of intact dog oocytes and 57% of intact wolf cells. Open systems were also used to vitrify granulosa-oocyte complexes (GOC) from primary follicles of marsupials. In two different studies the fat-tailed dunnart (*Sminthopsis crassicaudata*) (Czarny et al., 2009b) and the Tasmanian devil (*Sarcophilus harrisii*) (Czarny & Rodger, 2010) GOC were vitrified in self-made OPS. Post-warming viability was about 70% in both studies. Immature oocytes of the lowland gorilla (*Gorilla gorilla gorilla*) were also cryopreserved, using slow freezing. Of the thawed oocytes, 4/6 were morphologically degenerated, one arrested at the GV stage and the other progressed to the MI stage and then arrested (Lanzendorf, 1992). Immature oocytes of chousingha (*Tetracerus quadricorni*) were also vitrified using the OPS as a carrier system but post warming maturation rate (29.4%) was considerably lower than that of fresh oocytes (69.3%) (Rao et al., 2011). What unifies all these studies is the fact that only small number of oocytes were cryopreserved and only *in vitro* post thaw / warming evaluations were conducted.

Species	Model	Liquid nitrogen	Nitrogen slush	Sig.	Refernce
Bovine	MII oocytes	40% cleavage	25% cleavage	NS	(Martino et al., 1996)
Bovine	MII oocytes	28% cleavage	48% cleavage	P<0.05	(Arav & Zeron, 1997)
Ovine	GV-oocytes	25% survival	5% survival	P<0.05	(Isachenko et al., 2001)
Porcine	Early blastocysts	77% survive	95% survive	NS	(Cuello et al., 2004)
Rabbit	MII oocytes	83% survive	82% survive	NS	(Cai et al., 2005)
Porcine	Blastocysts	62% survive	83% survive	P<0.05	
Bovine	MII oocytes	39% survive	48% survive	P<0.05	(Santos et al., 2006)
Mouse	4-cell embryo with biopsy	50% survive	87% survive	P<0.05	(Lee et al., 2007)
Mouse	Blastocysts	10% survive	54% survive	P<0.05	(Yavin et al., 2009)
Rabbit	Morulae	83% develop	92% develop	P<0.05	(Papis et al., 2009)
Mouse	MII oocytes	45% survive	90% survive	P<0.001	(Lee et al., 2010)
Human	MII oocyte	56% survive	92% survive	P<0.05	(Criado et al., 2010)

NS = not significant.

Table 2. When oocytes or embryos from various species were vitrified in liquid nitrogen slush in comparison to regular vitrification, results either showed no difference or, more frequently, that slush was superior.

Immature oocytes seem to be less prone to damages caused by the chilling, freezing and thawing or warming procedures (Arav et al., 1996) and they, too, can be cryopreserved by slow freezing (Luvoni et al., 1997) or vitrification (Arav et al., 1993; Czarny et al., 2009b). Preantral oocytes can be preserved inside the follicle and about 10% seem to be physiologically active after thawing and one week of culture. Of over 16,000 small preantral oocytes recovered from the ovaries of 25 cats, 66.3% were intact after thawing (Jewgenow et al., 1998). Before freezing 33.9% of the follicles contained viable oocytes while after thawing there were 19.3% if frozen in Me<sub>2</sub>SO and 18.5% if frozen in 1,2-propanediol. However, culture conditions that will allow these oocytes to grow and reach full maturation are still largely unknown despite attempts in several species (Jewgenow et al., 1998; Nayudu et al., 2003). For example, in the marmoset monkey, oocytes collected from secondary pre-antral follicles of either mature or pre-pubertal females were able to develop *in vitro* to the polar body stage but could not complete the maturation process (Nayudu et al., 2003). The exception is the mouse, in which this was done and embryos were produced following IVF of frozen-thawed primary follicles matured *in vitro* and live young were born after embryo transfer (Carroll et al., 1990). Some, very limited, success was also reported in cats, where following vitrification in 40% ethylene glycol, 3.7% of the *in vitro* matured oocytes were able to develop to the blastocyst stage following IVF (Murakami et al., 2004). The problems associated with maturation of early-stage oocytes *in vitro* are the need to develop the complex endocrine system that support the development at different stages, other culture conditions that will ensure survival (oxygen pressure for example) and, in many species, the duration of time required to keep the follicles in culture – 6 months or more. An alternative to isolated oocyte cryopreservation is cryopreservation of individual primordial follicles and later transplanting them to the ovarian bursa, where they can mature and eventually produce young offspring following natural mating as was shown in mice (Carroll & Gosden, 1993).

Liquid-phase sperm preservation is relatively simple. Doing the same with oocytes was, until recently, much more challenging. A recent report on pig oocytes, however, has demonstrated ambient-temperature (27.5°C) preservation for 3 days with as many as 65% of the GV oocytes maintaining viability and developmental competence (Yang et al., 2010). This study demonstrated that oocyte preservation without freezing for several days is possible and relatively simple. This is of great importance for wildlife as cryopreservation or IVF of oocytes collected from dead animals in the field often cannot be done on the spot. The ability to keep oocytes alive while transporting them to the laboratory will considerably increase the number of possibilities.

### 3.2 Embryo cryopreservation

As discussed earlier with regards to oocytes, the vast difference in size, components and associated structures between spermatozoa on the one hand and oocytes and embryos on the other make cryopreservation of the latter much more complex. The issue of intracellular ice formation becomes a major concern, even at relatively slow cooling rates. To avoid this from happening, small volume cryopreservation and either high cryoprotectant concentration coupled with very fast cooling rate to achieve a state of vitrification or lower cryoprotectant concentration and slow cooling rate (slow freezing) are utilized. The first report on fertilized eggs cryopreservation was on rabbit fertilized ova frozen to -79°C (Ferdows et al., 1958). Some of these cryopreserved ova resulted in pregnancies after

thawing and transfer. This abstract, however, seem not to have been followed by a full peer-reviewed manuscript so it is not clear if those zygotes really froze and resulted in pregnancies. In 1971 another report on successful mouse embryo cryopreservation to  $-79^{\circ}\text{C}$ , using 7.5% polyvinylpyrrolidone (PVP) as cryoprotectant, was published, reporting post-thaw *in vitro* development to blastocysts and *in vivo* development to day-18 fetuses (Whittingham, 1971). Several researchers tried to repeat these results but none was successful (Whittingham et al., 1972; Wilmut, 1972; Ashwood-Smith, 1986; Leibo & Oda, 1993). The real start of the embryo cryopreservation era can therefore be considered as the year 1972. During that year two groups reported successful cryopreservation of mouse embryos to  $-196^{\circ}\text{C}$  (Whittingham et al., 1972; Wilmut, 1972). These reports came more than two decades after Polge et al. (1949) reported their chance observation that led to successful freezing of spermatozoa and opened a new era in cryobiology and assisted reproduction. Despite the decades that went by and numerous studies attempting a plethora of protocols and combinations of cryoprotectants, it is amazing to note that besides modification to cooling rate that came a few years later (Willadsen et al., 1976; Willadsen et al., 1978), the same basic protocol is still in vast use today. From conservation standpoint, embryo cryopreservation has the advantage of preserving the entire genetic complement of both parents. Naturally, a number of both male and female embryos should be stored to ensure representation of both sexes and a wide genetic diversity. Since sexing each embryo before cryopreservation is not practical, a large number of embryos should be preserved to increase the probability for sufficient representation of embryos from both sexes. Cryobanking of embryos can thus help establishing founder population with the aim of eventual reintroduction into the wild (Ptak et al., 2002) or revive isolated small population. However, while millions of offspring were born following the transfer of cryopreserved embryos in humans, cattle, sheep and mice, success is very limited in many other, even closely related species. To date the number of species in which embryo cryopreservation has been reported stands at less than 50 mammals (human, domestic and laboratory animals included), with live birth achieved in only about half of them (Table 3). There are also a few reports on non-mammalian embryo cryopreservation, all of them in fish (Table 3). Looking through the table, one can see that the majority of species in which embryo cryopreservation led eventually to pregnancy and live birth are domestic, companion, and laboratory species and species of commercial value. Only very few are truly wildlife species. Much of the knowledge gained came from studies on model animals since endangered species are too rare and studying them directly is often too difficult or practically impossible. By definition, however, each species has a unique reproductive specialization so, no matter how close we get with the aid of model animals, we must in the end gain access to the target species and verify that what worked in the model also works in the target. For example, studies on the domestic cat helped develop various technologies, which were later used in non-domestic cats (Dresser et al., 1988; Pope et al., 1994; Pope, 2000), or cattle served as a model for other ungulates (Dixon et al., 1991; Loskutoff et al., 1995). Too often direct adaptation is not possible and either adjustments to protocols or complete revision are required, forcing researchers to settle for small animal study population, at times comprised of a single animal (e.g. Robeck et al., 2011), and samples that are hard to come by. As in the case of oocytes, slow freezing and vitrification are currently used for embryo cryopreservation. Unlike oocytes, however, slow freezing has been producing good results so vitrification does not occupy as important a role in embryo cryopreservation as it does with oocytes. Two main sources of embryos can be considered - *in vivo* produced embryos and those

produced *in vitro*. These two embryo groups can develop *in vivo* to produce live offspring but the *in vivo* produced embryos seem to be superior to the *in vitro* ones in many respects, including their sturdiness and ability to survive cryopreservation (Rizos et al., 2002). Obtaining *in vivo*-produced embryos from an endangered species for cryopreservation is a difficult ethical question. If pregnancy has already occurred, shouldn't we let it proceed? Still, because of their superiority, *in vivo*-produced embryos were used in many of the studies on embryo cryopreservation in wildlife.

Species	Procedure	Outcome	References
<b>Primates</b>			
Human ( <i>Homo sapiens</i> )	4 to 8-cell, freezing, 4 to 16-cell freezing	Pregnancy, Pregnancy to term	(Trounson & Mohr, 1983; Zeilmaker et al., 1984)
Baboon ( <i>Papio</i> sp.)	<i>In vivo</i> -produced 6-cell to blastocyst, freezing	Pregnancy to term	(Pope et al., 1984)
Marmoset monkey ( <i>Callithrix jacchus</i> )	<i>In vivo</i> -produced 4 to 10-cells and morulae freezing	Pregnancy to term	(Hearn & Summers, 1986; Summers et al., 1987)
Cynomolgus monkey ( <i>Macaca fascicularis</i> )	IVF, 4 to 8-cell freezing 2 to 8-cell vitrification	Pregnancy <i>In vitro</i> survival	(Balmaceda et al., 1986; Curnow et al., 2002)
Rhesus macaque ( <i>Macaca mulatta</i> )	IVF, early-stage freezing ICSI blastocysts vitrification	Pregnancy to term  Pregnancy to term	(Wolf et al., 1989; Yeoman et al., 2001)
Hybrid macaque [pig-tailed ( <i>Macaca nemestrina</i> ) & lion-tailed ( <i>M. silenus</i> )]	IVF, 2-cell freezing	Pregnancy to term	(Cranfield et al., 1992)
Western lowland gorilla ( <i>Gorilla gorilla gorilla</i> )	IVF, 2-cell freezing	Not reported	(Pope et al., 1997a)
<b>Ungulates</b>			
Bovine ( <i>Bos taurus</i> )	<i>In vivo</i> -produced blastocysts freezing	Pregnancy to term	(Wilmut & Rowson, 1973; Willadsen et al., 1978)
Sheep ( <i>Ovis aries</i> )	<i>In vivo</i> -produced morula and blastocyst freezing	Pregnancy to term	(Willadsen et al., 1974, 1976)
Goat ( <i>Capra aegagrus</i> )	<i>In vivo</i> -produced morula and blastocyst freezing	Pregnancy to term	(Bilton & Moore, 1976)

Species	Procedure	Outcome	References
Horse ( <i>Equus caballus</i> )	<i>In vivo</i> -produced blastocysts freezing	Pregnancy to term	(Yamamoto et al., 1982; Slade et al., 1985)
African eland antelope ( <i>Taurotragus oryx</i> )	Details not provided	Stillbirth	(Kramer et al., 1983; Dresser et al., 1984; both cited in Schiewe, 1991)
Arabian Oryx ( <i>Oryx leucoryx</i> )	<i>In vivo</i> -produced morula freezing	Transferred but no pregnancy	(Durrant, 1983)
Gaur ( <i>Bos gaurus</i> )	<i>In vivo</i> -produced blastocysts freezing	Transferred to both cow and gaur. Pregnancy at day 135 in cow	(Stover & Evans, 1984; Armstrong et al., 1995)
Bongo ( <i>Tragelaphus euryceros</i> )	<i>In vivo</i> -produced blastocysts freezing	Transferred but outcome not reported	(Dresser et al., 1985)
Swine ( <i>Sus domestica</i> )	<i>In vivo</i> -produced blastocysts freezing to -35°C and -196°C	Pregnancy to term from -35°C, no pregnancy from -196°C	(Hayashi et al., 1989)
Scimitar-horned Oryx ( <i>Oryx dammah</i> )	<i>In vivo</i> -produced morula and blastocysts freezing	Transferred but no pregnancy	(Schiewe et al., 1991a)
Red deer ( <i>Cervus elaphus</i> )	<i>In vivo</i> -produced blastocysts freezing	Pregnancy by ultrasound	(Dixon et al., 1991)
Suni Antelope ( <i>Neotragus moschatus zuluensis</i> )	8-cell freezing	Transferred but no pregnancy	(Schiewe, 1991)
Water buffalo ( <i>Bubalis bubalis</i> )	<i>In vivo</i> -produced morula and blastocysts freezing	Pregnancy to term	(Kasiraj et al., 1993)
Fallow deer ( <i>Dama dama</i> )	<i>In vivo</i> -produced morula and blastocysts freezing	Pregnancy by ultrasound at day 45.	(Morrow et al., 1994)
Domestic donkey ( <i>Equus acinus</i> )	<i>In vivo</i> -produced blastocysts freezing	Outcome not reported	(Vendramini et al., 1997)
Dromedary camel ( <i>Camelus dromedarius</i> )	<i>In vivo</i> -produced blastocysts freezing and vitrification	Freezing – pregnancy by ultrasound, vitrification – pregnancy to term	(Skidmore & Loskutoff, 1999; Nowshari et al., 2005)

Species	Procedure	Outcome	References
Wapiti ( <i>Cervus canadensis</i> )	Details not mentioned	Pregnancy to term	(cited in Rall, 2001)
European mouflon ( <i>Ovis orientalis musimon</i> )	IVF blastocysts vitrification	Outcome not reported	(Ptak et al., 2002)
Llama ( <i>Lama glama</i> )	<i>In vivo</i> -produced blastocysts freezing and vitrification	Pregnancy by ultrasound after vitrification	(Aller et al., 2002; Lattanzi et al., 2002)
Wood bison ( <i>Bison bison athabasca</i> )	IVF morula and blastocysts vitrification	Not evaluated	(Thundathil et al., 2007)
Sika deer ( <i>Cervus nippon nippon</i> )	IVF blastocysts freezing	Pregnancy to term in red deer surrogate hind	(Locatelli et al., 2008)
<b>Carnivores</b>			
Domestic cat ( <i>Felis catus</i> )	<i>In vivo</i> -produced blastocysts freezing	Pregnancy to term	(Dresser et al., 1988)
African wildcat ( <i>Felis silvestris</i> )	IVF morula and blastocysts freezing	Pregnancy to term in domestic cat	(Pope et al., 2000)
Siberian Tiger ( <i>Panthera tigris altaica</i> )	IVF 2 to 4-cell freezing and vitrification	<i>In vitro</i> development of vitrified only	(Crichton et al., 2000; Crichton et al., 2003)
Blue fox ( <i>Alopex lagopus</i> )	Frozen and vitrified embryos, stage and source not mentioned	Both transferred and implanted but not carried to term	(cited in Farstad, 2000a)
Ocelot ( <i>Leopardus pardalis</i> )	IVF (stage not reported) freezing	Pregnancy to term	(Swanson, 2001, 2003)
Tigrina ( <i>Leopardus tigrinus</i> )	IVF 2 to 8-cell freezing	Not evaluated	(Swanson et al., 2002)
Bobcat ( <i>Lynx rufus</i> )	<i>In vivo</i> -produced blastocyst freezing	Transferred but no pregnancy	(Miller et al., 2002)
European Polecat ( <i>Mustela putorius</i> )	<i>In vivo</i> -produced morula and blastocysts freezing and vitrification.	Pregnancy to term in both cryopreservation techniques	(Lindeberg et al., 2003; Piltti et al., 2004)
Caracal ( <i>Felis caracal</i> or <i>Caracal caracal</i> )	IVF day 5 to 6 freezing	Pregnancy to term	(cited in Swanson, 2003; Pope et al., 2006)
Geoffroy's cat ( <i>Felis geoffroyi</i> )	Source and technique not mentioned	Outcome not mentioned	(Swanson & Brown, 2004)

Species	Procedure	Outcome	References
Serval ( <i>Leptailurus serval</i> )	IVF morula and blastocysts freezing	Transferred but no pregnancy	(Pope et al., 2005)
Dog ( <i>Canis lupus familiaris</i> )	<i>In vivo</i> -produced 1-cell to blastocyst vitrification	Pregnancy to term from 8 to 16-cell embryos	(Suzuki et al., 2009)
Clouded leopard ( <i>Neofelis nebulosa</i> )	IVF and ICSI day-five freezing	Transferred but no pregnancy	(Pope et al., 2009)
<b>Glires</b>			
European rabbit ( <i>Oryctolagus cuniculus</i> )	Fertilized ova frozen to -79°C, later 4 to 16-cell and morula freezing to -196°C and vitrification.	Confirmed pregnancy and later pregnancy to term by freezing and <i>in vitro</i> survival for vitrification	(Ferdows et al., 1958; Bank & Maurer, 1974; Whittingham & Adams, 1974, 1976; Popelkova et al., 2009)
Mouse ( <i>Mus musculus</i> )	<i>In vivo</i> -produced 8-cell freezing	Live fetuses to term	(Whittingham et al., 1972; Wilmut, 1972)
Rat ( <i>Rattus norvegicus</i> )	<i>In vivo</i> -produced 2 to 8-cell freezing and blastocysts vitrification	Confirmed pregnancy on day 18 for freezing, pregnancy to term for vitrification	(Whittingham, 1975; Kono et al., 1988)
Syrian hamster ( <i>Mesocricetus auratus</i> )	<i>In vivo</i> -produced 1-cell to morula freezing and 1 to 2-cell vitrification	Confirmed pregnancy on day 14 for freezing and pregnancy to term for vitrification	(Ridha & Dukelow, 1985; Lane et al., 1999)
Mongolian gerbil ( <i>Moriones unguiculatus</i> )	<i>In vivo</i> -produced 2-cell, morula and blastocyst vitrification	Pregnancy to term	(Mochida et al., 2005)
<b>Marsupials</b>			
Fat-tailed dunnart ( <i>Sminthopsis crassicaudata</i> )	<i>In vivo</i> -produced day 2 to 4 freezing and vitrification	<i>In vitro</i> survival in both systems	(Breed et al., 1994)

Species	Procedure	Outcome	References
<b>Others (fish)</b>			
Zebrafish ( <i>Danio rerio</i> )	6-somite and heartbeat stage vitrification	No viability	(Zhang & Rawson, 1996)
Turbot ( <i>Psetta maxima</i> )	Tail bud and tail bud free stages vitrification	No viability	(Robles et al., 2003)
Flounder ( <i>Paralichthys olivaceus</i> )	14-somite to pre-hatching stage vitrification	Post-warming hatching	(Chen & Tian, 2005)
Gilthead seabream ( <i>Sparus aurata</i> )	Tail bud and tail bud free stages vitrification	No viability	(Cabrita et al., 2006)
Red seabream ( <i>Pagrus major</i> )	Heart beat stage vitrification	No viability	(Ding et al., 2007)
Cascudo preto ( <i>Rhinelepis aspera</i> )	Blastoporous closing stage freezing to -8°C for 6h	Post-thaw hatching	(Fornari et al., 2011)

Table 3. Embryo cryopreservation in vertebrates. The table make it clear that attempts were made almost only in mammals and success in terms of pregnancy carried to term was achieved almost only in domestic, laboratory or companion species and species of commercial value.

### 3.2.1 Mammals

#### 3.2.1.1 Non-human primates

The number of cryopreserved human embryos successfully transferred since the first report on birth resulting from a transfer of a frozen-thawed embryo (Trounson & Mohr, 1983) is probably over half a million. Yet, despite the fact that non-human primates are used as laboratory models for humans in many studies, progress in primate embryo cryopreservation has been very limited (Mazur et al., 2008) and reports are scarce but with promising results. Observing the progress in non-human primate embryo cryopreservation, it seems that in this field humans act as models for other primates rather than the other way around. The first report on the birth of a non-human primate (baboon; *Papio* sp.) following transfer of frozen-thawed embryo came in 1984, about a year after similar report in humans (Pope et al., 1984). Six *in vivo* produced embryos were retrieved and frozen using glycerol as cryoprotectant. All six embryos survived the freeze-thaw procedure and resulted in two pregnancies (33.3%) after being transferred to six recipients. A similar report on cryopreservation of *in vivo* produced embryos in marmoset monkey (*Callithrix jacchus*) showed higher pregnancy rates (Hearn & Summers, 1986; Summers et al., 1987). In one of these studies, for example, 70% (7/10) of cryopreserved four- to 10-cell embryos and 56% (5/9) of cryopreserved morulae resulted in pregnancies (Summers et al., 1987). Five pregnancies of the first and four of the latter were carried to term resulting in six babies in each group. These authors noted that 1.5M Me<sub>2</sub>SO was superior to 1.0M glycerol; the latter



causing severe osmotic damage. Relying on success in IVF followed by embryo transfer (Balmaceda et al., 1984), pregnancies resulting from frozen-thawed IVF-produced embryos in cynomolgus monkeys (*Macaca fascicularis*) were reported (Balmaceda et al., 1986). Fifty-six cynomolgus macaque embryos were cryopreserved at the four- to eight-cell stage using 1.5 M Me<sub>2</sub>SO as cryoprotectant and the slow-freezing technique. After thawing, 39 embryos (70%) were still viable. Of these, 25 were transferred to nine synchronized recipients 24 to 48 h after ovulation, resulting in three pregnancies. Report on pregnancy carried to term from frozen-thawed transferred embryo in the rhesus macaque (*Macaca mulatta*) came not too long after that (Wolf et al., 1989). Using hormonal stimulation to achieve superovulation, oocytes (68% mature) were retrieved and inseminated *in vitro*. Embryos were then cryopreserved at the three- to six-cell stage following a propanediol-based freezing protocol, originally developed for humans. Embryo post-thaw survival was high (100%; 11/11). After transferring two embryos to each of three recipients during the early luteal phase of spontaneous menstrual cycles, one pregnancy was achieved and was carried to term. The same group also attempted *in vitro* maturation (IVM) of oocytes prior to IVF, freezing and transfer (Lanzendorf et al., 1990). Oocytes collected at the germinal vesicle (GV) stage did not fertilize *in vitro* and fertilization rate of those collected at the metaphase I (MI) stage was low (32%), even if these were matured *in vitro* to the metaphase II (MII) stage. Fertilization rate of oocytes collected at the MII stage was high (93%) and eight embryos frozen and transferred at the two- to six-cell stage to four recipients (two embryos to each) resulted in three pregnancies culminating in the delivery of three twins. Cross-species IVF was also attempted using *in vitro*-matured oocytes from the non-endangered pig-tailed macaque (*Macaca nemestrina*) and sperm from the endangered lion-tailed macaque (*M. silenus*) (Cranfield et al., 1992). Of the 65 oocytes collected, 25 (38%) were fertilized and 15 (24%) have developed to good quality embryos. These embryos were cryopreserved in propanediol-based extender and the slow freezing technique. Nine embryos were transferred to naturally cycling *M. nemestrina* foster mothers, one of which delivered a healthy hybrid male infant. In Western lowland gorilla (*Gorilla gorilla gorilla*), associated *in vitro* techniques (IVM, IVF, IVC) were adopted successfully from humans (Pope et al., 1997a). Of eight embryos at the two-cell stage produced *in vitro*, three were transferred to a single female, leading to a pregnancy and birth of a female infant. The other five embryos were cryopreserved in 1.5 M 1,2-propanediol containing cryoprotectant. Regrettably, cryopreservation outcome was not reported.

Vitrification is a good alternative to the slow freezing. Following the lead of human and laboratory and farm animals' embryo cryopreservation, the use of vitrification was attempted and compared to slow freezing in non-human primates as well (Yeoman et al., 2001; Curnow et al., 2002). Early-stage (two- to eight-cells) cynomolgus macaque embryos were used to compare vitrification using open pulled straw (OPS) as a carrier system to slow freezing (Curnow et al., 2002). Vitrification proved to be inferior to slow freezing in cell survival rate (18 to 29% vs. 82%), embryo survival (26 to 32% vs. 90%) and cleavage rate (29 to 38% vs. 83%). In another study, on rhesus monkey blastocysts cryopreservation, vitrification using the cryoloop as a carrier system was compared to slow freezing (Yeoman et al., 2001). Embryos were produced *in vitro* by ICSI into mature oocytes and then *in vitro* cultured to the blastocyst stage. Cryopreservation was carried out by either the slow freezing technique or vitrification using two different cryoprotectant combinations – 2.8M

Me<sub>2</sub>SO with 3.6M EG (combination A) or 3.4M glycerol with 4.5M EG (combination B). Similar results were achieved when blastocysts were cryopreserved by slow freezing [8/22 (36.4%) embryos survived and 1/22 (4.5%) hatched following co-culture] or combination A of cryoprotectants [6/16 (37.5%) embryos survived and 1/16 (6.3%) hatched]. In comparison, using vitrification with cryoprotectant combination B 28/33 (84.8%) of the blastocysts survived and 23/33 (69.7%) hatched. This last study not only achieved high embryonic survival using vitrification, it has also demonstrated the suitability of this technique to overcome the problem of advanced-stage embryo preservation. Six embryos vitrified with cryoprotectant combination B and transferred to three recipients (two to each) resulted in a twin pregnancy carried to term.

### 3.2.1.2 Ungulates

Embryo cryopreservation has reached a commercial level in the cattle industry and to a lesser extent in sheep and goats. According to a report of the International Embryo Transfer Society (IETS), 297,677 *in vivo*-derived frozen-thawed bovine embryos were transferred in 2008 worldwide, representing 55.2% of all transferred *in vivo*-derived bovine embryos in that year (Thibier, 2009). There were also 26,914 frozen-thawed IVF embryos, comprising 10.6% of all transferred bovine IVF embryos in 2008. The actual numbers are most probably much larger since not all transfers are reported to IETS. Major Asian countries such as China, India, Korea and Thailand as well as some of the South American countries did not report their activities to IETS and the reports from Oceania are only partial. At least four important factors are responsible for this success: availability of almost unlimited number of oocytes for research, the possibility to collect *in vivo* produced embryos non-surgically and without the need for anesthesia or sedation, the availability of financial resources to finance overwhelming body of studies and the needs of the cattle industry. Because none of these factors is helping to push studies on endangered ungulates, situation is dramatically less developed in other species of this group. Statements in reviews on assisted reproductive technologies in non-domestic ungulates from only a decade ago were to the effect that by that time only one successful embryo cryopreservation has been achieved (Holt, 2001). Non-domestic ungulates usually do not show discernable signs of estrous and their receptive period is fairly short. This requires a thorough understanding of the estrus cycle endocrine activity, methods for its monitoring in each species under study and the development of species-specific hormonal administration for ovarian stimulation. As in all other wildlife species, one should always keep in mind that what works for one species not necessarily will also work for another, even closely related species. For example, the bovine IVC protocol works well for the water buffalo (*Bubalis bubalis*) but when this protocol was used for the African buffalo (*Syncerus caffer*), embryos did not develop beyond the morula stage (Loskutoff et al., 1995). Hormonal monitoring can be achieved non-invasively through fecal or urine analysis but even developing such techniques is not always eventless and not always successful (Paris et al., 2008). Hormonal administration requires stress-afflicting activities such as repeated darting, general anesthesia or movement restriction by chute. Thus, progress in this field has been slow and efficiency in *in vitro* technologies (IVM, IVF, IVC) has been low. For example, in the Kudu (*Tragelaphus* sp.), of 397 oocytes collected, 79 zygotes cleaved yet only two blastocysts were achieved (0.5%) (Loskutoff et al., 1995). Another example is the Mohor gazelle (*Gazella dama mhorr*) in which embryos produced by IVF with frozen-thawed semen did not develop beyond the six- to eight-cell stage (Berlinguer et al., 2008). These studies suggest that while embryo cryopreservation is a

technology worthwhile pursuing, other associated technologies should also reach a level of maturation to support it.

The European mouflon (*Ovis orientalis musimon*) is a wild sheep threatened by extinction. During the efforts to develop the necessary assisted reproductive technologies, the domestic sheep was used as a model. Using 25% glycerol and 25% ethylene glycol as cryoprotectants, *in vitro* produced embryos at the expanded blastocyst stage were vitrified (Ptak et al., 2002). Twenty blastocysts were transferred to domestic sheep foster mothers (two embryos each). At 40 days, seven of the sheep were pregnant and three carried the pregnancy to term, delivering four normal mouflon offspring. In another study, *in vivo* produced embryos were vitrified following embryo vitrification protocol developed for sheep (Naitana et al., 1997; Naitana et al., 2000). Of the five vitrified blastocysts, four survived and were transferred to four synchronized domestic sheep ewes, two of which became pregnant and one pregnancy was carried to term. The domestic sheep, and in part the cow as well, acted as a model for the scimitar-horned Oryx (*Oryx dammah*) as well. After developing the needed methods, including embryos collection, cryopreservation and transfer, in the sheep, the gained knowledge was used in the scimitar-horned Oryx. *In vivo* produced embryos were frozen in propylene glycol or glycerol but no specific results were reported (Wildt et al., 1986). In another, later study performed on scimitar horned Oryx embryos, thirty late morula- to blastocyst-stage embryos were frozen in cryoprotectant containing Me<sub>2</sub>SO, glycerol, or propylene glycol, 10 embryos in each (Schiewe et al., 1991a). Survival was higher in the Me<sub>2</sub>SO and glycerol groups. Although the majority (67%) of *in vitro*-cultured embryos developed into hatched blastocysts after 48 h, no pregnancies were established following nonsurgical (n = 8) or laparoscopic (n = 1) transfer of the remaining transferable embryos. Another Oryx species in which an attempt to cryopreserve embryos was made is the Arabian Oryx (*Oryx leucoryx*). Morula-stage *in vivo*-produced embryos were collected and one was frozen in 1.5M Me<sub>2</sub>SO. After thawing, the embryo was rated as having a good quality grade. It was transferred to a scimitar-horned Oryx foster female but failed to produce a pregnancy following surgical transfer (Durrant, 1983). Another failed attempt concerns cryopreservation of suni antelope (*Neotragus moschatus zuluensis*) eight-cell stage embryos (N. Loskutoff, personal communication cited in Schiewe, 1991). Of the 18 embryos frozen, nine completely degenerated after thawing. The other nine embryos were transferred by laparoscopy despite the fact that all of them exhibited partial blastomere degradation. No pregnancies were achieved. Attempts were also carried out to freeze *in vivo* produced embryos of African eland antelope (*Taurotragus oryx*) and bongo (*Tragelaphus euryceros*) using glycerol as cryoprotectant. Post-thaw evaluations indicated that six of seven eland (Dresser et al., 1984) and bongo (Dresser et al., 1985) embryos were considered viable and of good enough quality for transfer. Damage to the zona pellucida was noted in one of the eland embryos. Only one pregnancy was carried to term but resulted in a stillborn eland offspring due to dystocia. This attempt was followed by subsequent transfer attempts that resulted in a live eland offspring (B.L. Dresser, personal communication cited in Schiewe, 1991).

The red deer (*Cervus elaphus*), an animal of commercial value in various parts of the world, can also act as a model animal for other closely related species. Slow freezing of red deer *in vivo*-produced embryos in 1.4M glycerol followed by embryo transfer in another country resulted in pregnancy rate ranging between 50 and 72% in different farms, with an average pregnancy rate of 61.2% (153/247) (Dixon et al., 1991). In another study, slow freezing was

compared to vitrification by the OPS technique and fresh embryos as control (Soler et al., 2007). Pregnancy rates were 64.3% (18/28), 53.3% (8/15) and 70.0% (7/10) for fresh, vitrified and frozen embryos, respectively. The knowledge accumulated through experiments on red deer was used to freeze embryos from fallow deer (*Dama dama*) (Morrow et al., 1994). *In vivo*-produced embryos resulting from AI were collected surgically from fallow deer and transferred either fresh or following cryopreservation to recipients. Pregnancy rate of frozen-thawed embryos was half that of fresh (26% vs. 53%) and the overall efficiency of the program was low (0.9 to 1.0 surrogate pregnancy per donor). Another deer species in which embryos cryopreservation was attempted is sika deer (*Cervus nippon nippon*). Here, too, the protocol developed for the red deer (Dixon et al., 1991) was used. Of 142 oocytes collected following chemical synchronization, 57 (40.1%) cleaved after IVF and 14 of them reached the blastocyst stage. These embryos were cryopreserved by slow freezing and were later transferred (two per recipient) to synchronized red deer hinds. One of the seven recipients delivered a healthy young sika deer fawn after 224 days of pregnancy (Locatelli et al., 2008).

The domestic cow has acted as a model for other members of the Bovinae subfamily. The gaur (*Bos gaurus*), a member of this subfamily living in the forested areas of South and South East Asia is classified in the IUCN red list as vulnerable. Following protocols developed for the cow, nine *in vitro* produced blastocysts were cryopreserved. One embryo was transferred to a domestic cow which was confirmed pregnant on day 135 (Armstrong et al., 1995). Cryopreservation of gaur embryos was reported more than a decade earlier (Stover & Evans, 1984) however that report did not elaborate on the freezing protocol nor was any information provided as to the outcome of the procedure. Another member of this subfamily is the wood bison (*Bison bison athabasca*), a sub species of the North American bison. Using IVM, IVF, IVC and vitrification protocols developed for bovine, *in vitro*-produced embryos were vitrified (Thundathil et al., 2007). Regettably, protocols that works very well for cattle, gave fairly poor results in wood bison. Only 6.9% (11/160) of the embryos reached the blastocyst stage. Morula-stage (n=27) and blastocyst-stage (n=6) embryos were vitrified. Disappointingly, the researchers failed to report on the evaluation of the embryos after warming.

Camelids are seasonal breeders and induced ovulators. *In vivo*-produced embryos of dromedary camel (*Camelus dromedarius*), collected at the blastocyst stage, were vitrified. Post-warming survival and intact morphology were high (92%) and following transfer of 45 embryos (20 during the breeding season and 25 off-season), three pregnancy were obtained, one of which was carried to term (Nowshari et al., 2005). This report follows a previous one in which cryopreserved embryos did not lead to a pregnancy after transfer (Skidmore & Loskutoff, 1999). Among the South American camelids, attempts have reached some level of success in the Llama (*Lama glama*) whose embryos were found to be three- to five-fold larger than bovine embryos of the same stage (Lattanzi et al., 2002). In one attempt, *in vivo* produced hatched blastocysts were either vitrified or frozen slowly (Lattanzi et al., 2002). After 24 h of *in vitro* culture, 64% (21/33) of the vitrified embryos and in 63% (12/19) of the slow freezing embryos re-expanded. In another attempt to vitrify llama embryos, 10/40 embryos re-expanded after warming (von Baer et al., 2002). Three fresh-chilled and two vitrified-warmed embryos were transferred to synchronized recipients but only one of the fresh embryos resulted in a pregnancy. In yet another report from about the same time, by a different group, success was achieved. *In vivo* produced embryos were collected non-surgically and vitrified at the expanded blastocyst stage. Eight embryos were transferred after warming to four recipients (two embryos, each) and two of them became pregnant, delivering two offspring (Aller et al., 2002).

As for other members of this group, some but very modest success have been reported on cryopreservation of domestic species like the horse (Yamamoto et al., 1982; Slade et al., 1985; Barfield et al., 2009; Choi et al., 2009) and swine (Nagashima et al., 1995; Dobrinsky et al., 2000) but very little success have been reported in other species.

### 3.2.1.3 Carnivores

The order Carnivora includes two suborders – Caniformia (dog-like species) and Feliformia (cat-like species). Similar to cows among the ungulates, the domestic dog (*Canis lupus familiaris*) and cat (*Felis catus*) are representatives of these two suborders and are highly accessible in terms of their frequent use as laboratory animals and the availability of large number of ovaries from neutered or euthanized animals. Still, despite these similarities and their being members of the same order, embryo cryopreservation and all associated technologies are highly developed for cats but lagging far behind in dogs. The domestic cat was found to be a very suitable model for other felid species, which may partially explain why things are more advanced among felids. Felines are induced ovulators (the release of LH that leads to ovulation is induced by mating) and mostly seasonal breeders. The first report on successful IVF and IVC to the blastocyst stage in a cat came in 1977 (Bowen, 1977). Eleven years later the first in-depth study on cat IVF and the first report on birth of live kittens after embryo transfer of cryopreserved, *in vivo*-derived embryos at the morula stage were published (Dresser et al., 1988; Goodrowe et al., 1988). Cryopreservation was carried out using the slow freezing technique and glycerol as cryoprotectant. However, success rate of embryo transfer was relatively low (14.4%, 17/118), most probably because all thawed embryos were transferred, regardless of their grade. Subsequently, production of offspring after transfer of *in vitro*-derived embryos from *in vivo* and *in vitro* matured oocytes and with or without post thaw culture were described (Pope et al., 1994; Wolfe & Wildt, 1996; Pope et al., 1997b; Wood & Wildt, 1997; Pope et al., 2002). Recently it was suggested that removing some of the lipids from the embryo before cryopreservation, a process known as delipidation, result in higher survival rate and higher rates of post-thaw development to morula and blastocyst stages (Tharasanit & Techakumphu, 2010).

Differences between the domestic cat and other feline species still exist and transfer of knowledge is not entirely straightforward. Still, following the success in the domestic cat, maturation and *in vitro* fertilization of oocytes from a large number of feline species was demonstrated (Johnston et al., 1991). This included tiger (*Panthera tigris*), lion (*Panthera leo*), leopard (*Panthera pardus*), jaguar (*Panthera onca*), snow leopard (*Panthera uncia*), puma (*Felis concolor*), cheetah (*Acinonyx jubatus*), clouded leopard (*Neofelis nebulosa*), bobcat (*Lynx rufus*), serval (*Felis serval*), Geoffroy's cat (*Felis geoffroyi*), Temminck's golden cat (*Felis temmincki*), and leopard cat (*Felis bengalensis*). A total of 846 oocytes were recovered from ovaries of 35 individuals from these 13 species, 508 of them were of fair to excellent quality, yet only 4 (0.8%) cleaved – one of leopard using homologous sperm and three of puma using domestic cat sperm. Matured oocytes were achieved in all but fertilization was not achieved in jaguar, cheetah, clouded leopard, bobcat and Temminck's golden cat. In another study, on puma, 6/25 recovered oocytes fertilized and five of them cleaved (Jewgenow et al., 1994). Success in IVF came at about the same time in other species, e.g. in the tiger (Donoghue et al., 1990), the Indian desert cat (*Felis silvestris ornata*) (cited in Pope, 2000) or leopard cat (*Felis bengalensis*) (Goodrowe et al., 1989). Pope (2000) also mentions IVF/ET in African wild cat (*Felis silvestris lybica*) but pregnancy here ended with stillbirths.

Over the past decade or so, several reports on embryo cryopreservation in felids appeared in the scientific literature. Some investigators, using the domestic cat as a surrogate mother for frozen-thawed embryos of similar-sized wild feline species, produced offspring of ocelot (*Felis pardalis*) (Swanson, 2001) and the African wild cat (Pope et al., 2000). Transfers of frozen-thawed embryos to conspecific recipients have often failed to produce live offspring. In clouded leopard, no pregnancies were achieved with either frozen-thawed or control embryos (Pope et al., 2009). Similarly, frozen-thawed morula-stage cervial embryos failed to result in pregnancies after transfer (Pope et al., 2005). In the bobcat (*Lynx rufus*), out of three transferred embryos – two fresh and one frozen-thawed, one pregnancy (from a fresh embryo) was achieved (Miller et al., 2002). Failure, however, was not a universal phenomenon. In the ocelot (*Felis pardalis*) over 80 IVF embryos, representing 15 founders of the North American population of this species were cryopreserved for safekeeping (Swanson, 2003) and two pregnancies were established following laparoscopic transfer of frozen-thawed embryos (Swanson, 2006). IVF was also carried out in tigrina (*Leopardus tigrinus*), another South American wild felid, and the resulting embryos (n=52) were cryopreserved (Swanson et al., 2002). Regrettably, the researches failed to report on post-thaw evaluation. In caracal (*Felis caracal*) from 452 recovered matured oocytes, 297 embryos were produced. Additional 16 embryos were produced following IVM of 83 oocytes. A total of 109 embryos were cryopreserved using slow freezing. Of nine recipients, three became pregnant and three kittens were delivered (Pope et al., 2006). Vitrification was also attempted in wild felids and was shown to produce superior results as compared to slow freezing. Siberian tiger (*Panthera tigris altaica*) oocytes were collected by laparoscopy from chemically stimulated ovaries. Following IVF with frozen-thawed sperm and IVC to the 2- to 4-cell stage, embryos were cryopreserved by either slow freezing or vitrified. None of the slow freezing embryos survived (0/89). From those vitrified, 46% (32/70) survived (Crichton et al., 2000; Crichton et al., 2003).

Whereas some success has been achieved in felids, situation is lagging far behind in canids and progress has been slow (Farstad, 2000a, b). Associated ART techniques such as IVM, IVF and IVC still face many difficulties and outcome is often unpredictable, most probably because *in vitro* culture media and conditions are not optimized for this group (Rodrigues & Rodrigues, 2006; Mastromonaco & King, 2007). In the vast majority of the studies, dog zygotes did not progress to the advanced embryonic developmental stages – morula and blastocyst (Rodrigues & Rodrigues, 2006). The first successful embryo cryopreservation in dogs, leading to pregnancy after ET, was reported only in 2007 (Abe et al., 2007) and pup delivery following embryo cryopreservation came two years later (Suzuki et al., 2009). This success was later repeated with *in vivo*-produced embryos using vitrification as the cryopreservation method (Abe et al., 2011). Canine females are unique in their reproductive cycle in the fact that the ovulated oocytes are still immature and their maturation may take two or more days (estimated at 48 to 60 h) while in the distal uterine horn. Also unique is the fact that luteinization and the increase in progesterone actually occur before ovulation (Reynaud et al., 2005; Chastant-Maillard et al., 2011; Concannon, 2011). The extra-follicular maturation process has proved hard to mimic and to date *in vitro* maturation and fertilization are not yet developed in dogs. The bitch anatomy makes retrieval of *in vivo*-produced embryos very difficult, leading researchers to resort to a complete surgical removal of the uterus and associated structures, a procedure that limits its application. From the same reason, embryo transfer was also done surgically until the recent development of a non-surgical technique (Abe et al., 2011). Canine oocytes and early-stage embryos also have

high lipid content (Reynaud et al., 2005) making their cryopreservation challenging. These multiple factors are responsible for the slow progress in ART developments in canids. Despite extensive search, the only report on embryo cryopreservation in a non-domestic canid found in the scientific literature is a few words on a trial with blue fox (*Alopex lagopus*) embryos. These were cryopreserved by slow freezing and vitrification and were later transferred to recipients. Although no live pups were achieved, two implantation sites from each of the two cryopreservation techniques were found. (Personal communication with H. Lindeberg, cited in Farstad, 2000a).

Some progress has also been reported in other carnivore families. In the Mustelidae family, a member of the caniformia suborder, some species are of commercial value, primarily in the fur industry. These include, for example, the European polecat (*Mustela putorius*) and the American mink (*Mustela vison* or *Neovision vison*). Other members in this family are listed as endangered or critically endangered species, including the black-footed ferret (*Mustela nigripes*) and the European mink (*Mustela lutreola*). The species of commercial value can thus act as models for developing reproduction technologies and for gaining needed knowledge on specific attributes of the Mustelidae family. European polecat, for example, acted as a model for the European mink and the first successful embryo cryopreservation in this family was reported in this species (Lindeberg et al., 2003). Surgically recovered *in vivo*-produced European polecat embryos were cryopreserved by slow freezing and resulted, following surgical transfer, in 3/8 pregnancies and nine pups were delivered out of a total of 93 embryos transferred (9.7%). A second paper by the same group (Piltti et al., 2004) reported on the first successful embryo vitrification in carnivores. Out of 98 European polecat *in vivo*-produced embryos at the morula and blastocyst stages, 50 survived and were transferred to four recipients. Two of the recipients delivered a total of eight pups, a success rate similar to that of slow freezing (8/98; 8.2%). Further improvements came when a different vitrification technique, pipette tip, was used. Using this technique, 43.6% (44/101) of the embryos survived vitrification and resulted in live births (Sun et al., 2008). Vitrified embryos that were cultured for two or 16 h before transfer resulted in success rate (71.3% and 77.4% live births, respectively) similar to that of the control (79.3%) and significantly higher than in embryos cultured for 32 h (25%) and 48 h (7.8%).

### 3.2.1.4 Glires – rodents and lagomorphs

Mouse was the first animal in which embryo cryopreservation was reported (Whittingham et al., 1972; Wilmut, 1972). Since then work on glires has largely concentrated on mice, rats, gerbils, hamsters and rabbits – all species in extensive laboratory use. The major cryoprotectant used for freezing embryos in this group is Me<sub>2</sub>SO. Although vitrification seem to be gradually taking the lead and many studies claim similar results to fresh controls, a recent meta-analysis found that vitrification is still inferior to fresh embryos (Manno III, 2010). It also found that a variety of covariates are associated with vitrified but not fresh embryos. These include issues such as the time lapse between hCG treatment and embryo cryopreservation, maternal age, and the time from hCG treatment to post-warming assessment. These and possibly other factors might be the result of heterogeneity of conditions of the studies included in such analysis but they can also be real factors arising from the process of cryopreservation. In rabbits, using *in vivo* produced embryos and either slow freezing (Bank & Maurer, 1974; Whittingham & Adams, 1974, 1976) or vitrification (Popelkova et al., 2009; Mocè et al., 2010), resulted in fairly high survival (up to 83%) and pregnancy (up to 92%) rates. However, rate of young born was still relatively low, in the range of 7 to 17% (Bank

& Maurer, 1974; Whittingham & Adams, 1974, 1976). In rats both slow freezing and vitrification were attempted, with considerably better results in the latter. *In vivo* produced embryos at the two-, four- and eight-cell stages were recovered and frozen with 3.0M Me<sub>2</sub>SO. Post-thaw normal morphology recovery rate ranged between 65% and 68%. Rate of embryos carried to term, however, was low - 11% for two-cell embryos, zero for four-cell embryos and 9% for eight-cell embryos (Whittingham, 1975). In contrast, in the vitrification study, 79% (117/149) of the vitrified *in vivo* produced blastocysts were morphologically normal after warming. These were split between *in vitro* culture (n=48) and transfer to recipient rats (n=69). All cultured embryos progressed to expanded and hatched blastocysts and of the 69 embryos transferred, 41% (n=28) resulted in live pups (Kono et al., 1988). The golden hamster, also known as the Syrian hamster (*Mesocricetus auratus*), is another member of this group in frequent use as a laboratory research subject. *In vivo* produced embryos at the one- and two-cell stages were flushed and vitrified by the cryoloop technique (Lane et al., 1999). Of 216 vitrified two-cell embryos, 54.2% continued development to the morula/blastocyst stage after warming. Such embryos were transferred to two recipients who delivered 6 pups. In another study, *in vivo* produced embryos at the eight-cell stage were vitrified in 250µL straws, following the technique developed for mouse embryos (Mochida et al., 2000). This study evaluated only *in vitro* development and this was fairly poor, as only two out of 37 embryos developed to the blastocyst stage. Similar to the hamster, *in vivo*-produced Mongolian gerbil (*Mesocricetus auratus*) embryos were vitrified in 250µL straws (Mochida et al., 1999). Following vitrification, 155 embryos developed to the blastocyst stage were transferred to 10 synchronized females, 3 of which became pregnant and delivered 15 pups (9.7%). In a follow-up study by the same group it was shown that embryos at later developmental stages (four-cell, morula and blastocyst) can also be vitrified and result in very high post-warming normal morphology (ranging between 87% and 100%) (Mochida et al., 2005). In this last study, after transfer into recipient females, 3% (4/123), 1% (1/102), 5% (4/73), and 10% (15/155) of embryos developed to full-term offspring from vitrified-warmed early two-cell embryos, late two-cell embryos, morulae, and blastocysts, respectively. The general tendency in all glires seem to be the same - post-thaw/warming *in vitro* quality of the embryos is good but when transferred to recipient females, only around 10% of transferred embryos develop to term. The study by Kono and colleagues (1988) with the reported 41% pups delivered is the exception to this rule. When vitrification was attempted, it seems to result in better outcome.

### 3.2.1.5 Marsupials

Marsupials are very different from eutherian mammals in many respects, attributes related to their oocytes is one of them. Their oocytes are about twice as large as those of humans (about 200 to 250 µm vs. 100 to 120 µm in humans) (Rodger et al., 1992; Breed et al., 1994). The size is probably that large because of the very large yolk sac that occupies much of the cell volume. The much larger volume and the large yolk compartment make their cryopreservation even more difficult than that of the already hard-to-cryopreserve eutherian oocytes. The alternative is to cryopreserve embryos and in that direction only a single report was found (Breed et al., 1994). In that study, *in vivo*-produced embryos of the carnivorous fat-tailed dunnart (*Sminthopsis crassicaudata*) were cryopreserved by slow freezing or vitrification. Me<sub>2</sub>SO proved to be not suitable for vitrification of embryos in this species as none of the embryos vitrified with this cryoprotectant cleaved after warming. Embryos cryopreserved by slow freezing or vitrification (with ethylene glycol as cryoprotectant) had similar cleavage rates or 17% and 18%, respectively. Even when morphological examination



found embryos to be normal, examination by electron microscopy revealed multiple damages to intracellular components.

### 3.2.2 Cetaceans

Only very few studies have reported attempts at cryopreservation of marine mammals oocytes and the only ones I was able to locate were on the common minke whale (*Balaenoptera acutorostrata*). These include studies on both slow freezing (Asada et al., 2000; Asada et al., 2001) and vitrification (Iwayama et al., 2005; Fujihira et al., 2006). To date, no study reporting embryo cryopreservation in cetaceans has been published (O'Brien & Robeck, 2010).

### 3.2.3 Non-mammal vertebrates

Whereas embryo cryopreservation in mammals shows some success, at least in those extensively studied species, situation lagging far behind in all other vertebrates (fishes, birds, reptiles and amphibians). It is true that considerably less efforts have been invested in embryo cryopreservation in most members of these groups, but the more important cause is the different structure embryos in these vertebrates have, difference that complicates their cryopreservation. From the little that has been done in these vertebrates, the vast majority of studies were done on fish (primarily the zebrafish; *Dino rerio*) and to a lesser extent also in amphibians – the two classes with the smaller oocytes among the non-mammalian vertebrates. The ensuing discussion will therefore be primarily on fishes as representatives for these classes. When sex chromosomes are the determination method, as is the case in most vertebrates, either the male or the female can be the heterogametic sex. In mammals the male carry both X- and Y-chromosomes while the female carries two copies of X-chromosome. In birds, on the other hand, it is the female that carry the Z- and W-chromosomes while the male carries two copies of the Z-chromosome. In fishes and amphibians both systems can be found. To have both chromosomes represented, one should aim to at least preserve enough gametes of the heterogametic sex. In many of the non-mammal species this means preserving the female's gametes, which, as will be discussed here, is problematic. Several attributes differentiate oocytes in these classes from those of mammals. To start with, they are considerably larger, resulting in lower surface area to volume ratio. For example, while the diameter of human oocyte is ~120 µm or that of the mouse is ~80 µm, oocyte of the zebrafish is ~750 µm (Selman et al., 1993) or that of the marsh frog (*Rana ridibunda*) is ~1,400 µm (Kyriakopoulou-Sklavounou & Loumbourdis, 1990), oocytes of the American alligator (*Alligator mississippiensis*) are ~4,000 µm (Uribe & Guillette, 2000), those of the pink salmon (*Oncorhynchus gorbuscha*) in the range of 5,150 to 6,340 µm, and the sizes go even higher in snakes such as kingsnakes (genus: *Lampropeltis*) with diameter of about 22,000 µm (Tryon & Murphy, 1982), and birds like the Japanese quail (*Coturnix coturnix japonica*) – 17,000 to 19,000 µm (Callebaut, 1973) or the domestic chicken (*Gallus gallus domesticus*) with a diameter of about 35,000 to 40,000 µm (Schneider, 1992). The consequence of this is relatively poor water and cryoprotectant movement across the cellular membrane during chilling, freezing and thawing. The difference in size also means considerably larger volume of water to vitrify, thus greatly increasing the risk for intracellular ice formation and cell death. Fish embryos contain a large yolk compartment, enclosed in the yolk syncytial layer (YSL). The behavior of the yolk during freezing defer

from the behavior of other embryonic compartments, making freezing very complex. These embryos have at least three membrane structures (YSL, plasma membrane of the developing embryo and the chorionic membrane which surrounds the perivitelline space) (Kalicharan et al., 1998; Rawson et al., 2000). Each of these membranes has a different permeability coefficient for water and cryoprotectants, resulting, for example, in water permeability in the range of one order of magnitude lower in fish embryos compared to other animals - 0.022 to 0.1  $\mu\text{m} \times \text{min}^{-1} \times \text{atm}^{-1}$  in zebrafish (Hagedorn et al., 1997a) compared to 0.722 in drosophila (Lin et al., 1989) or 0.43 in mice (Leibo, 1980). To complicate things even further, the different embryonic compartments have different water content and different osmotically inactive water content (Hagedorn et al., 1997b). Since the chorionic membrane can be removed enzymatically (by pronase) and its removal does not hinder embryonic development (Hagedorn et al., 1997c), Hagedorn et al. (1997a) suggested that the YSL was the primary barrier to cryoprotectants resulting in the yolk sac reaching lower levels of cryoprotection compared to other embryonic compartments. Using magnetic resonance microscopy, they have shown that while no cryoprotectant injected into the yolk was able to leave, some cryoprotectant was able to enter the blastoderm (Hagedorn et al., 1996). Attempts to solve this permeability issue by adding aquaporin 3 water channels to the zebrafish embryonic membranes (Hagedorn et al., 2002) or inserting cryoprotectants into the yolk by microinjection (Janik et al., 2000) were unsuccessful. Efforts to test various permeating and non-permeating cryoprotectants including methanol,  $\text{Me}_2\text{SO}$ , glycerol, 1,2-propanediol, PG, EG, trehalose, and sucrose also took place. Embryos were shown to be very sensitive to glycerol and EG at a concentration of 1.5M, but less so to methanol,  $\text{Me}_2\text{SO}$  or PG (Hagedorn et al., 1997c). Studies also showed that later-stage embryos were less chilling sensitive than early-stage ones and thus probably more suitable for cryopreservation (Zhang & Rawson, 1995). However, attempts to cryopreserve fish embryos by slow freezing or vitrification generally met with lack of success. (reviewed in Robles et al., 2009). For instance, when intact embryos were cryopreserved by slow freezing, only about 2% of the cells in them survived the process (Harvey, 1983). Attempts were also carried out to cryopreserve amphibian (the frog *Xenopus*) oocytes with similar lack of success (Guenther et al., 2006; Kleinhans et al., 2006).

So, if oocytes and embryos are not an option at the moment, the alternatives are blastodermal cells and primordial germ cells. These cells can be cryopreserved by slow freezing (Naito et al., 1992; Naito et al., 1994) or vitrification (Kohara et al., 2008; Higaki et al., 2010) with good over all post-thaw/warming viability. Goose blastodermal cells, cryopreserved by slow freezing resulted in relatively low survival rate of 25% or less, depending on the cryovial used (Patakine Varkonyi et al., 2007). In another study, quail blastodermal cells were isolated, cryopreserved and the thawed viable cells were used to create quail-chicken chimeras (Naito et al., 1992). Chicken primordial germ cells had survival rate of  $85.8 \pm 1.2\%$  and  $91.2 \pm 2.8\%$  for vitrified-warmed and frozen-thawed cells, respectively with no significant difference between treatments and the control (Kohara et al., 2008). Blastodermal cells can be used to create chimeras, which are organisms made out of cells from two or more donors with different genetic background. Using this system, duck blastodermal cells were injected into the subgerminal cavity of same stage gamma-irradiated chicken embryo to produce duck-chicken chimeras (Li et al., 2002). These chimeras were mated with ducks to produce six duck hatchlings (out of 622 eggs collected) indicating that, albeit at low efficiency, this system can produce offspring of the

blastodermal cells donor. The alternative, which seems to have higher potential from conservation point of view, is the preservation of primordial germ cells. These can later be allo- or xenotransplanted to produce viable offspring of the donor. As a demonstration of concept, primordial germ cells from pheasant (*phasianus colchicus*) were injected into the bloodstream of domestic chicken (*Gallus gallus domesticus*) embryos to produce pheasant-chicken chimeras (Kang et al., 2008). Back-crossing chimera males with pheasant females produced 10 pheasant chicks with an efficiency of 17.5%. Chimera offspring were also generated in zebrafish by transplanting GPC from various sources including vitrified embryoid, an aggregate of cells derived from embryonic stem cells (Kawakami et al., 2010). The male chimeras were then mated with normal females through natural spawning to produce offspring.

In conclusion, cryopreservation of embryos in the few mammalian species in which it was attempted shows some, though very limited, success. The situation is much less advanced in all other vertebrates (fish, birds, reptiles and amphibians) where noticeably less efforts have been invested and the challenges are often considerably more complex. In comparison to mammals, embryos in all these classes are usually larger in volume, with large amount of yolk and multiple membranes showing varying permeability to water and cryoprotectants. All these make embryos in these classes highly susceptible to chilling injury and, with the currently available knowledge and techniques, make their cryopreservation extremely complicated and often practically impossible. The alternative approach, at least for now, would therefore be to preserve blastodermal cells and primordial germ cells, which can be transplanted into host embryos to produce offspring.

### 3.3 Ovarian tissue cryopreservation

Cryopreservation of ovarian tissue has several advantages over oocyte or embryo cryopreservation, but it also comes with its unique complications. As was discussed earlier, in the section on testicular tissue cryopreservation, tissue is a complex structure and thus presenting many difficulties with respect to cryopreservation. Ovarian tissue is available at any time, season, stage in cycle, and age – from fetus to old to deceased. It contains large number of oocytes and, to overcome the problems associated with *in vitro* development and maturation, it can be implanted so that this can take place *in vivo* (Candy et al., 1995) or after partial development *in vivo*, oocytes can be retrieved and matured *in vitro* (Liu et al., 2001). Ovarian tissue also contains premeiotic germ cells, even in aged animals whose ovaries are otherwise devoid of follicles (Niikura et al., 2009). By transplanting such ovaries into recipient young adult animals can help generate new follicles. Attempts to cryopreserve ovarian tissue were reported already in 1951 (Smith & Parkes), only two years after the same group discovered the protective effect of glycerol during freezing (Polge et al., 1949). The first live birth following ovarian tissue freezing and transplantation was reported in mice, in which the tissue was frozen to -79°C (Parrott, 1960). Grafts can be transplanted to the owner of the tissue (autotransplantation), to another member of the species (allotransplantation) or to a member of a different species (xenotransplantation). All three possibilities were successfully used to support follicular development in grafted tissue. When it comes to wildlife conservation, ovarian tissue will not be used in a similar manner to the way it is used in human medicine, namely retransplanted into its donor. Rather, these cryopreserved tissues will be used to collect oocytes by isolation and maturation *in vitro* or by transplanting them to immune deficient host animals (usually mice or rats) that will support oocyte

development *in vivo*. Although ovarian tissue grafting is usually done under the kidney's capsule where ample of blood vessels are found, other locations like subcutaneous grafting for easy access have also been reported (Cleary et al., 2003). Transplantation can be to either female or male recipient (Weissman et al., 1999; Snow et al., 2002) and, interestingly, in a study on human ovarian cortex transplantation to non-obese diabetic-severe combined immune deficiency (NOD-SCID) mice, more males (76.5%, 13/17) supported follicular development than females (30%, 6/20) (Weissman et al., 1999). In another study, while more xenografts were retrieved from females, the number of oocytes recovered from each xenograft was higher in those transplanted to males (Snow et al., 2002). Oocytes developed in males, however, showed reduced fertilizing ability and none of the transferred embryos resulted in implantation. The tissue, cut of its blood supply from harvesting till about 48h after transplantation, needs to rely on its surrounding for supply of oxygen and nutrients and removal of CO<sub>2</sub> and other wastes. If not completely lost or rejected, ischemia can thus lead to the death of more than half of the follicles in the graft (Candy et al., 1997). The surviving follicles, though may grow and develop after transplantation, often contain oocytes of suboptimal quality (Kim et al., 2005). Transplanted ovarian tissue, like any transplanted tissue, carries the risk of transmitting diseases from donor to recipients, a risk that is greatly elevated by the need to use immune-deficient recipients to reduce the risk of graft rejection. The alternative to grafting is growing the follicles to maturation *in vitro*. This, however, has been demonstrated thus far only in mice where primordial follicles (Eppig & O'Brien, 1996) or primary follicles (Lenie et al., 2004) were cultured successfully *in vitro*.

The standard cryopreservation protocol, which seems to work for many different species, is cryopreservation of ovarian cortical tissue slices with a size of 1 to 2 mm<sup>3</sup> in cryoprotective solution containing Me<sub>2</sub>SO, ethylene glycol or 1,2-propanediol. The tissue and the cryoprotective solution are equilibrated at 0°C and then again at -5 to -7°C. Seeding to initiate extracellular freezing is performed and the sample is then cooled at a slow and constant rate of 0.3°C to 0.5°C/min till somewhere between -30°C and -80°C, before being plunged into liquid nitrogen for storage (for review see Paris et al., 2004). An alternative technique proposed a few years ago does not require expensive equipment and is suitable for work under field conditions (Cleary et al., 2003). Following this technique, equilibration is performed on ice, and the sample is then placed in a passive freezing device that is placed on dry ice. Using this device, a cooling rate of about 1°C/min can be achieved. This is faster than optimal cooling rate but still tolerable. When freezing wombat (*Vombatus ursinus*) ovarian cortical tissue slices this way, 134 ± 32 intact follicles per graft were found compared to 214 ± 55 for the controlled-rate freezing machine.

Cryopreserved ovarian tissue, which was later auto-, allo- or xenografted, has been done in a variety of species including humans (Weissman et al., 1999; Gook et al., 2001; Gook et al., 2003; Donnez et al., 2004), non-human primates - rhesus macaque (*Macaca mulatta*) (Lee et al., 2004), cynomolgus macaque (*Macaca fascicularis*) (Schnorr et al., 2002) and common marmoset (*Callytrix jacchus jacchus*) (von Schönfeldt et al., 2011), bovine (Herrera et al., 2002), sheep (Gosden et al., 1994), cats (Gosden et al., 1994; Jewgenow et al., 1997; Bosch et al., 2004; Jewgenow & Paris, 2006; Luvoni, 2006), mice (Parrott, 1960; Liu et al., 2000; Liu et al., 2001), rabbits (Almodin et al., 2004), common wombat (*Vombatus ursinus*) (Wolvekamp et al., 2001; Cleary et al., 2003), African elephant (*Loxodonta Africana*) (Gunasena et al., 1998), Amur leopard (*Panthera pardus orientalis*) and African lion (*Panthera leo*) (Jewgenow et al., 2011), tamar wallaby (*Macropus eugenii*) (Mattiske et al., 2002), and Fat-tailed dunnart

(*Sminthopsis crassicaudata*) (Shaw et al., 1996). The last two are of special interest as they demonstrate that even when xenografting between species so philogenetically distant as marsupials and mice, the graft is still supported and oocytes can develop. Primordial oocytes in ovarian tissue are probably less prone to cooling and cryopreservation damages when compared to mature ones because they are smaller in size and they lack zona pellucida. Still, recovery rate is low. In cats, for example, only 10% of the follicles survived freezing, thawing and transplantation-associated ischemia (Bosch et al., 2004). To overcome this low harvesting rate, multiple grafts are required.

The alternative cryopreservation approach that has been applied to gametes and embryos, namely vitrification, has been applied to ovarian tissue as well. Naturally, to achieve good cryoprotectant penetration and proper heat transfer the sample should be thin enough, normally in the range of 1 mm or less. Several groups have experimented with this approach, cryopreserving tissue samples from humans (Isachenko et al., 2009), mice (Salehnia et al., 2002), sheep (Baudot et al., 2007), pig (Gandolfi et al., 2006), cow (Kagawa et al., 2009), goat (Santos et al., 2007), dog (Ishijima et al., 2006) and cynomolgus and rhesus macaques (Yeoman et al., 2005). The general trend in recent years is for similar outcome from slow freezing and vitrification (see recent review by Amorim et al., 2011)

### 3.4 Whole ovary cryopreservation

Cryopreservation of large volumes, including whole organs, involves several aspects, which make any attempt at cryopreservation a challenge (Arav & Natan, 2009). These difficulties include: 1) the need for efficient heat transfer throughout the tissue. When a thick tissue or whole organs are involved, this is very difficult to accomplish, 2) the need for efficient cryoprotectant penetration to all cells in the tissue. This is challenging because of the tissue thickness and because different cell types in it have different permeability coefficients and different sensitivities. Excessive exposure time may be damaging to some cells in the tissue due to cryoprotectant toxicity while shorter time might not provide sufficient protection to others. Thus, the optimal time slot is to be identified, 3) supercooling (cooling below the solution's freezing point without crystallization) may take place in some parts of the tissue. This may lead to damages from uncontrolled intra- and extracellular ice formation once crystallization occurs, 4) attaining homogenous cooling rate while avoiding the excessive build-up of toxic concentrations of cryoprotectants, 5) during cryopreservation, latent heat is released from the solution. This released heat can induce recrystallization and extend the isothermal stage, resulting in the development of a large temperature difference between the tissue/organ and the surrounding. This may lead to faster-than-optimal cooling once all latent heat has been released, 6) recrystallization may also occur during thawing because of inhomogeneous warming of the sample. Still, if these issues can be overcome, whole ovary presents one very important advantage over ovarian tissue when it comes to cryopreservation. One of the major problems with cryopreserving ovarian cortical tissue is the ischemia the graft goes through when transplanted. This ischemia cause both graft loss and death of large portion of the follicles within surviving grafts. Cryopreserving whole ovary, including its vascular pedicle, can ensure blood supply as soon as the organ has been transplanted (Bromer & Patrizio, 2009). For the grafted ovary to become fully functional, both ovaries of the recipient should be removed (Liu et al., 2008). Grafting the ovary can be done to its natural position or to any other location in the body that may provide easy

access. Of course ovary transplanted to another location can produce oocytes that should be harvested for use *in vitro*. First whole ovary cryopreservation reported was in sheep (Revel et al., 2001; Revel et al., 2004). This report used directional freezing technique, which is claimed to provide a solution to many of the issues involved in large volume cryopreservation mentioned above (Arav & Natan, 2009). Most other cryopreservation experiments used controlled-rate freezing equipment to achieve the desired very slow ( $\sim 0.1^\circ\text{C}/\text{min}$ ) cooling rate needed. This first report was followed by reports on cryopreserving ovaries of various other species such as rats (Wang et al., 2002; Qi et al., 2008), mice (Liu et al., 2008), bovine (Arav, 2003), pigs (Imhof et al., 2004), human (Bedaiwy et al., 2006) and another study on sheep (Onions et al., 2009). In some of these studies, pregnancies were achieved and live young were produced. Interestingly, to date transplantation of cryopreserved whole human ovary has not been reported (Bromer & Patrizio, 2009) despite the fact that ovarian transplantation has been in practice for several years now and whole human ovary cryopreservation was attempted by several researchers.

Although vitrification is an attractive procedure for cryopreservation of whole ovaries, the current knowledge in cryobiology is insufficient to overcome the multiple problems involved in large volume vitrification (Fahy et al., 1990), primarily when tissue, rather than suspension, is involved. Keeping in mind the relationship between the three factors determining the probability of vitrification mentioned earlier (see section on semen vitrification and also Saragusty & Arav, 2011), to avoid cryoprotectant toxicity, very high cooling rates and very small sample volume are needed. Attempts at whole ovary vitrification did take place and in some cases, when the ovaries were sufficiently small, were even successful. An attempt to vitrify whole sheep ovary resulted in complete loss of all follicles (Courbiere et al., 2009). On the other hand, in studies on mice and rats, vitrification of whole ovary was successful (Migishima et al., 2003; Hoshina et al., 2009). One study showed acceptable post warming viability by *in vitro* evaluations of mice ovaries (Migishima et al., 2003). In another study follicular growth was demonstrated after autotransplantation under the kidney capsule of vitrified warmed rat ovaries (Sugimoto et al., 2000). In yet another study, live offspring were produced when the donor mice were transgenic so that their ovaries expressed anti-freeze protein type III as an additional mean of cryoprotection (Bagis et al., 2008).

With the big potential whole ovary cryopreservation holds for wildlife conservation, this procedure is yet to be reported in any animal other than laboratory or domestic species.

#### **4. Options equally good for both males and females**

Some options, as will be discussed in the following sections, are available for both sexes. These options are still largely experimental in nature, their efficiency is often low and they require well equipped laboratories with highly experienced staff so their widespread implementation in wildlife conservation is probably still years down the road. They are, however, worthy of mentioning because of the great potential they hold. These, and many of the options described in the previous sections, are not and may never become widely used techniques. They are also nowhere near the decades old slow freezing and vitrification and so, to be on the safe side one should probably opt for cryopreservation of gametes and embryos using one of the available techniques. However, by definition endangered species are species whose global population is small and declining. This means that with time the genetic diversity of such populations is dwindling. If we do not set up collections of samples

(gametes, embryos, somatic cells, or anything else we can put your hands on) of the genetic diversity, and just sit and wait for some new technology to come by or for breakthrough in one of the still experimental technologies at hand, genetic diversity within species and possibly entire species will be lost for ever. We should therefore aim to create banks that will hold samples from each endangered species on earth and of as wide a diversity of genetic make up as possible in each. Cryopreservation is a more mature technology for this purpose but many other options are advancing and may one day play an important role in long-term banking for wildlife conservation. New and much better technologies may emerge with time but we cannot sit and watch species going extinct and take no action. Collections should be created with any and all possible technologies in mind.

#### 4.1 Somatic cells cryopreservation for SCNT

To produce embryos *in vivo* or *in vitro*, conspecific spermatozoa and good quality oocytes are required, both or either of which often prove very difficult to obtain. An alternative that can circumvent this, at least in part, is preservation of somatic cells, to be later used for somatic cell nuclear transfer (SCNT, Wilmut et al., 1997). In SCNT, also known as cloning, nucleus of a somatic cell is microinjected into enucleated oocyte, which is then grown *in vitro* and can be later transferred to recipient females for development to term, with or without a cryopreservation step in between. Somatic cells from a wide variety of sources can be used for this purpose. Such diverse sources include cells from tissues preserved without cryoprotectant at  $-80^{\circ}\text{C}$  for more than a decade, or cells from tissues kept at  $-20^{\circ}\text{C}$  for as long as 16 years (Hoshino et al., 2009), cells isolated from mummified animals (Kato et al., 2009), freeze-dried somatic cells (Loi et al., 2008a; Ono et al., 2008; see next section), semen-derived somatic cells (Nel-Themaat et al., 2008a; Nel-Themaat et al., 2008b; Liu et al., 2010), cells collected postmortem (Oh et al., 2008), cell line (Campbell et al., 1996), and of course both fetal and adult cells are suitable for this purpose (Wilmut et al., 1997). SCNT has indeed an obvious potential for the multiplication of rare genotypes (Corley-Smith & Brandhorst, 1999; Loi et al., 2008a; Loi et al., 2008b), but its wide application is prevented by the currently low efficiency in terms of offspring outcome. To date, successful cloning was reported in sheep (Campbell et al., 1996; Wilmut et al., 1997; Loi et al., 2008a; Loi et al., 2008b), cow (Cibelli et al., 1998), mice (Wakayama & Yanagimachi, 1998), goat (Baguisi et al., 1999), pigs (Polejaeva et al., 2000), cats (Shin et al., 2002), dogs (Jang et al., 2007), rabbits (Chesne et al., 2002), ferrets (Li et al., 2006), mule (Woods et al., 2003), horse (Galli et al., 2003), gaur (*Bos gaurus*) (Lanza et al., 2000), buffalo (*Bubalus bubalis*) (Lu et al., 2005; Shi et al., 2007), mouflon (*Ovis orientalis musimon*) (Loi et al., 2001), African wild cat (*Felis silvestris libica*) (Gómez et al., 2003), wolves (*Canis lupus*) (Kim et al., 2007), mountain bongo antelope (*Tragelaphus euryceros isaaci*) (Lee et al., 2003) and eland (*Taurotragus oryx*) (Nel-Themaat et al., 2008b). When dealing with already extinct species, we can anticipate survival of nucleus DNA but not for viable oocytes. The only hope is then to use oocytes from closely related species. Interspecies SCNT (ISCNT), performed by injecting the nucleus from one species into the oocyte of another has also been carried out in a variety of species (for a recent review see Loi et al., 2011a). These include ISCNT from the endangered mouflon to a domestic sheep (*Ovis aries*) (Loi et al., 2001), from red panda (*Ailurus fulgens*) to rabbit (Tao et al., 2009), from sand cat (*Felis margarita*) to domestic cat (Gómez et al., 2008), from Canada lynx (*Lynx canadensis*) to both domestic cat and caracal (*Caracal caracal*) (Gómez et al., 2009), from water buffalo (*Bubalus bubalis*) to cow (*Bos taurus*) (Srirattana et al., 2011), and most strikingly - from a

15,000 year-old woolly mammoth (*Mammuthus primigenius*) to a mouse (Kato et al., 2009). While this technique holds much promise for the resurrection of extinct species and saving those on their way there (Loi et al., 2011b), with the exception of a few sporadic instances, all these attempts at ISCNT did not result in live offspring. Cryopreservation of reproductive tissue or any other viable body tissue or, alternatively, of *in vitro* grown cell cultures is routinely done in many places around the world and enough cells survive the process to be used in SCNT. Furthermore, obtaining tissue samples is usually much simpler than collecting gametes or embryos, so a larger and more diverse collection can be accumulated.

While SCNT has the advantage that no genetic drift takes place because recombination does not occur, when considering SCNT for wildlife species preservation, several important issues should be taken into consideration. First, as mentioned above, suitable enucleated oocytes are required. The availability of such oocytes and the ability to access them should thus be part of the program (Loi et al., 2011b). If conspecific oocytes are not available, the issues of mitochondrial inheritance and nucleus-cytoplasmic incompatibility become a problem and ways to overcome these should be sought for. When the donor and recipient are close enough, some of the donor mitochondria get transferred as well (Gómez et al., 2009; Srirattana et al., 2011). As was demonstrated for the famous sheep, Dolly, the telomere is shorter following SCNT (Shiels et al., 1999). Interestingly, it was recently shown that cloned cows with short telomeres produce normal and healthy offspring with normal telomere length following artificial insemination with sperm from normal bulls (Miyashita et al., 2011). This study suggests that cloning does not interfere with the eventual function of the germ line. Cloned offspring, however, are known to show elevated prevalence of developmental abnormalities and high mortality rate, issues that should be kept in mind when initiating a cloning program (e.g. Lanza et al., 2000). One should also keep in mind that the spermatozoa carry more than just genetic material. They come with a whole load of epigenetic factors important for proper embryonic development (Yamauchi et al., 2011). These are missing when SCNT is performed and might be one of the causes behind the relatively low efficiency of the process. As with cryopreservation of other cells and tissues, storage space and costs and environmental impact are major issue pertaining to liquid nitrogen storage so a cheaper alternative would be very attractive for long-term conservation purposes.

#### 4.2 Somatic cell drying for SCNT

In tissue banking, as in the banking of germ cells and embryos, storage and maintenance costs are always an issue because of the properties of liquid nitrogen. Seeds of plants, having low water content are relatively easy to preserve at high subzero temperatures (-20 to -30°C). With water content of about 80%, preservation of gametes and embryos in the animal kingdom is complicated and species-specific. The use of large quantities of liquid nitrogen for cryopreservation and storage also has its toll on the environment, as the production of liquid nitrogen is energy-intensive, resulting in the release of large quantities of carbon dioxide. An alternative to cryopreservation of somatic cells, then, can be to dry them and store the dry cells at room temperature. While, as was discussed earlier, sperm drying has been achieved in a number of species, the parallel in females, namely oocyte drying, is yet to be demonstrated. Somatic cell drying is thus the way to go when long-term storage for females or of the entire genetic complement is desired. In this respect, the use of sheep freeze-dried somatic cells for SCNT was recently demonstrated (Loi et al., 2008a; Loi et al., 2008b). In their report, utilizing the directional freezing technology, freeze-dried



granulosa cells, kept at room temperature for 3 years, were used to direct embryonic development following nuclear transfer into *in vitro* matured enucleated oocytes. The reconstructed oocytes initiated cleavage at similar rates to control embryos generated using fresh granulosa cells. Microsatellite DNA analysis of the cloned blastocysts matched perfectly with the lyophilized donor cells. Later, these results were confirmed by other researchers studying mouse granulosa cells (Ono et al., 2008), human hematopoietic stem and progenitor cells (Buchanan et al., 2010) or porcine fetal fibroblasts (Das et al., 2010). These studies demonstrate for the first time that dry cells maintain the development potential when injected into enucleated oocytes. Naturally, we still have a long way to go before live offspring will be generated using this technology but the potential is there.

### 4.3 Stem cell preservation

Embryos can be a source for primordial germ cells (PGC) which, as was shown in the zebrafish, can be vitrified, warmed and then transplanted into sterilized recipient blastulae to differentiate into males and females that produced gametes carrying the genetic material of the transplanted PGC donor (Higaki et al., 2010). Such PGC can be transplanted, along with gonadal somatic cells, and develop into normal male or female gonadal tissue with normal spermatogenesis or oogenesis. Both mouse round spermatids and GV oocytes derived from such tissues were able to direct embryonic development to term following ICSI (Matoba & Ogura, 2010). In a recent study on felids (Silva et al., 2011) it was shown that such germ line stem cells can be transplanted to the gonads of a different species and still develop normal early stage gametes. In that study, ocelot (*Leopardus pardalis*) spermatogonial stem cells were transplanted into domestic cat testis and thirteen weeks later ocelot spermatozoa were retrieved from the cat's epididymis.

Going even earlier in the development timeline, embryos can be a source for stem cells. Embryonic stem cells, being pluripotent, can differentiate *in vivo* or *in vitro* into germ cells. They can also be used for nuclear transfer. So, they, too, can be considered an optional venue. In a study on mice, transplanted embryonic stem cells were able to form testicular tissue structures and direct spermatogenesis (Toyooka et al., 2003). These cells, which can be isolated from embryos, can also be cryopreserved (Thomson et al., 1998; Toyooka et al., 2003) or vitrified (Reubinoff et al., 2001; He et al., 2008). Such stem cells can also be derived from embryos generated by nuclear transfer of freeze-dried cells (Ono et al., 2008). Embryonic stem cells can also be derived from isolated blastomeres, and blastomeres can also be cryopreserved individually by inserting them into emptied zona pellucida and then vitrifying them (Escriba et al., 2010). If embryonic stem cells are not available, somatic cells can be induced to become embryonic stem cells-like (Takahashi & Yamanaka, 2006), also known as induced pluripotent stem cells or iPS cells (for recent review see: Cox & Rizzino, 2010). Being pluripotent in nature, they are also germ line competent (Okita et al., 2007) and as such can give rise to germ cells of both male and female.

The fantastic options mentioned above are theoretical and speculative in nature when it comes to wildlife preservation as currently these techniques are in their infancy and were adapted thus far only to laboratory animals, and even in these the unknown is still vast.

## 5. Conclusion

With the dramatically accelerated species extinction rate we see in recent decades, it is our obligation to seek any possible venue to bring this biodiversity loss to a halt and, while

attempting to do so, to seek ways to safe-keep gametes, embryos and somatic cells from (ideally) all species on Earth. To our great disadvantage from a cryobiologist standpoint, species are different from each other and preservation techniques almost invariably require species-specific customization. As was discussed here, there are many options for 'putting life on hold'. Cryopreservation is by far the most advanced and widely used technique that has led to the establishment of several genome resource banks. Within cryopreservation, slow freezing currently holds the leading role but at least for oocytes, and slowly for embryos too, vitrification is gradually replacing it to become the cryopreservation technique of choice. Due to its small size, condensed DNA and little cytoplasm, spermatozoa are relatively easy to cryopreserve and this was already done in hundreds of species. Oocytes and embryos are much more difficult to obtain in large enough numbers to develop the needed protocols and, because of their large size, more difficult to cryopreserve. It is thus not surprising that oocytes or embryos of only a handful of wildlife species have been cryopreserved. An array of other options, including gonadal tissue and whole gonads cryopreservation, freeze-drying of spermatozoa and somatic cells, SCNT and ISCNT, to name just a few, are largely in the developmental or experimental stage and, if matured and improve in efficiency, they hold great promise and will become highly attractive to wildlife conservation and other fields concerned with 'putting life on hold'. These techniques will not replace the basic and well studied equilibrium freezing and vitrification but will help in supporting them as well as in handling cases in which routine cryopreservation cannot be done. While waiting for these and future technologies to mature and improve in efficiency we should strive to preserve whatever we can – gametes, embryos, gonadal tissue, whole gonads, somatic cells, and stem cells – anything we can. Such collections should be from sufficient number of representatives of each species so that we will be well prepared in the unfortunate event that a need will arise. As Benirschke (1984) put it: 'You must collect things for reasons we don't yet understand.'

## 6. References

- Abe, Y, Suwa, Y, Asano, T, Ueta, YY, Kobayashi, N, Ohshima, N, Shirasuna, S, Abdel-Ghani, MA, Oi, M, Kobayashi, Y, Miyoshi, M, Miyahara, K & Suzuki, H. (2011). Cryopreservation of Canine Embryos. *Biology of Reproduction* 84, 2, 363-368.
- Abe, Y, Suwa, Y, Lee, DS, Kim, SK & Suzuki, H. (2007). Vitrification of canine oocytes and embryos, and pregnancy after non-surgical transfer of vitrified embryos. *Biology of Reproduction* 77, 1 supplement, 134 (abstract).
- Aller, JF, Rebuffi, GE, Cancino, AK & Alberio, RH. (2002). Successful transfer of vitrified llama (*Lama glama*) embryos. *Animal Reproduction Science* 73, 1-2, 121-127.
- Almodin, CG, Minguetti-Camara, VC, Meister, H, Ferreira, JOHR, Franco, RL, Cavalcante, AA, Radaelli, MRM, Bahls, AS, Moron, AF & Murta, CGV. (2004). Recovery of fertility after grafting of cryopreserved germinative tissue in female rabbits following radiotherapy. *Human Reproduction* 19, 6, 1287-1293.
- Amaral, A, Paiva, C, Baptista, M, Sousa, AP & Ramalho-Santos, J. (2011). Exogenous glucose improves long-standing human sperm motility, viability, and mitochondrial function. *Fertility and Sterility* 96, 4, 848-850.
- Amorim, CA, Curaba, M, Van Langendonck, A, Dolmans, M-M & Donnez, J. (2011). Vitrification as an alternative means of cryopreserving ovarian tissue. *Reproductive Biomedicine Online* 23, 2, 160-186.

- Anel, L, Álvarez, M, Martínez-Pastor, F, Gomes, S, Nicolás, M, Mata, M, Martínez, AF, Borragán, S, Anel, E & de Paz, P. (2008). Sperm cryopreservation in brown bear (*Ursus arctos*): Preliminary aspects. *Reproduction in Domestic Animals* 43, s4, 9-17.
- Arav, A; Arav, Amir, assignee. (1999). Device and methods for multigradient directional cooling and warming of biological samples. US patent 5,873,254.
- Arav, A. (2003). Large tissue freezing. *Journal of Assisted Reproduction and Genetics* 20, 9, 351.
- Arav, A & Natan, Y. (2009). Directional freezing: a solution to the methodological challenges to preserve large organs. *Seminars in Reproductive Medicine* 27, 6, 438-442.
- Arav, A, Shehu, D & Mattioli, M. (1993). Osmotic and cytotoxic study of vitrification of immature bovine oocytes. *Journal of Reproduction and Fertility* 99, 2, 353-358.
- Arav, A & Zeron, Y. (1997). Vitrification of bovine oocytes using modified minimum drop size technique (MDS) is effected by the composition and the concentration of the vitrification solution and by the cooling conditions. *Theriogenology* 47, 1, 341 (abstract).
- Arav, A, Zeron, Y, Leslie, SB, Behboodi, E, Anderson, GB & Crowe, JH. (1996). Phase transition temperature and chilling sensitivity of bovine oocytes. *Cryobiology* 33, 6, 589-599.
- Arav, A, Zeron, Y, Shturman, H & Gacitua, H. (2002). Successful pregnancies in cows following double freezing of a large volume of semen. *Reproduction, Nutrition, Development* 42, 6, 583-586.
- Armstrong, DL, Looney, CR, Lindsey, BR, Gonseth, CL, Johnson, DL, Williams, KR, Simmons, LG & Loskutoff, NM. (1995). Transvaginal egg retrieval and *in-vitro* embryo production in gaur (*Bos gaurus*) with establishment of interspecies pregnancy. *Theriogenology* 43, 1, 162 (abstract).
- Asada, M, Horii, M, Mogoe, T, Fukui, Y, Ishikawa, H & Ohsumi, S. (2000). *In vitro* maturation and ultrastructural observation of cryopreserved minke whale (*Balaenoptera acutorostrata*) follicular oocytes. *Biology of Reproduction* 62, 2, 253-259.
- Asada, M, Wei, H, Nagayama, R, Tetsuka, M, Ishikawa, H, Ohsumi, S & Fukui, Y. (2001). An attempt at intracytoplasmic sperm injection of frozen-thawed minke whale (*Balaenoptera bonaerensis*) oocytes. *Zygote* 9, 4, 299-307.
- Asher, GW, Berg, DK & Evans, G. (2000). Storage of semen and artificial insemination in deer. *Animal Reproduction Science* 62, 1-3, 195-211.
- Ashwood-Smith, MJ. (1986). The cryopreservation of human embryos. *Human Reproduction* 1, 5, 319-322.
- Avarbock, MR, Brinster, CJ & Brinster, RL. (1996). Reconstitution of spermatogenesis from frozen spermatogonial stem cells. *Nature Medicine* 2, 6, 693-696.
- Bagis, H, Akkoc, T, Tass, A & Aktoprakligil, D. (2008). Cryogenic effect of antifreeze protein on transgenic mouse ovaries and the production of live offspring by orthotopic transplantation of cryopreserved mouse ovaries. *Molecular Reproduction and Development* 75, 4, 608-613.
- Baguisi, A, Behboodi, E, Melican, DT, Pollock, JS, Destrempe, MM, Cammuso, C, Williams, JL, Nims, SD, Porter, CA, Midura, P, Palacios, MJ, Ayres, SL, Denniston, RS, Hayes, ML, Ziomek, CA, Meade, HM, Godke, RA, Gavin, WG, Overstrom, EW & Echelard, Y. (1999). Production of goats by somatic cell nuclear transfer. *Nature Biotechnology* 17, 5, 456-461.

- Balmaceda, JP, Heitman, TO, Garcia, MR, Pauerstein, CJ & Pool, TB. (1986). Embryo cryopreservation in cynomolgus monkeys. *Fertility and Sterility* 45, 3, 403-406.
- Balmaceda, JP, Pool, TB, Arana, JB, Heitman, TS & Asch, RH. (1984). Successful *in vitro* fertilization and embryo transfer in cynomolgus monkeys. *Fertility and Sterility* 42, 5, 791-795.
- Bank, H & Maurer, RR. (1974). Survival of frozen rabbit embryos. *Experimental Cell Research* 89, 1, 188-196.
- Barfield, JP, McCue, PM, Squires, EL & Seidel, GE, Jr. (2009). Effect of dehydration prior to cryopreservation of large equine embryos. *Cryobiology* 59, 1, 36-41.
- Barnosky, AD, Matzke, N, Tomiya, S, Wogan, GOU, Swartz, B, Quental, TB, Marshall, C, McGuire, JL, Lindsey, EL, Maguire, KC, Mersey, B & Ferrer, EA. (2011). Has the Earth's sixth mass extinction already arrived? *Nature* 471, 7336, 51-57.
- Barone, MA, Roelke, ME, Howard, J, Brown, JL, Anderson, AE & Wildt, DE. (1994). Reproductive characteristics of male Florida panthers: Comparative studies from Florida, Texas, Colorado, Latin America, and North American zoos. *Journal of Mammalogy* 75, 1, 150-162.
- Bartels, P & Kotze, A. (2006). Wildlife biomaterial banking in Africa for now and the future. *Journal of Environmental Monitoring* 8, 8, 779-781.
- Baudot, A, Courbiere, B, Odagescu, V, Salle, B, Mazoyer, C, Massardier, J & Lornage, J. (2007). Towards whole sheep ovary cryopreservation. *Cryobiology* 55, 3, 236-248.
- Bedaiwy, MA, Hussein, MR, Biscotti, C & Falcone, T. (2006). Cryopreservation of intact human ovary with its vascular pedicle. *Human Reproduction* 21, 12, 3258-3269.
- Beebe, LFS, Cameron, RDA, Blackshaw, AW & Keates, HL. (2005). Changes to porcine blastocyst vitrification methods and improved litter size after transfer. *Theriogenology* 64, 4, 879-890.
- Behr, B, Rath, D, Hildebrandt, TB, Goeritz, F, Blottner, S, Portas, TJ, Bryant, BR, Sieg, B, Knieriem, A, de Graaf, SP, Maxwell, WMC & Hermes, R. (2009a). Germany/Australia index of sperm sex sortability in elephants and rhinoceros. *Reproduction in Domestic Animals* 44, 2, 273-277.
- Behr, B, Rath, D, Mueller, P, Hildebrandt, TB, Goeritz, F, Braun, BC, Leahy, T, de Graaf, SP, Maxwell, WMC & Hermes, R. (2009b). Feasibility of sex-sorting sperm from the white and the black rhinoceros (*Ceratotherium simum*, *Diceros bicornis*). *Theriogenology* 72, 3, 353-364.
- Benirschke, K. (1984). The frozen zoo concept. *Zoo Biology* 3, 4, 325-328.
- Berg, DK & Asher, GW. (2003). New developments reproductive technologies in deer. *Theriogenology* 59, 1, 189-205.
- Berlinguer, F, Gonzalez, R, Succu, S, del Olmo, A, Garde, JJ, Espeso, G, Gomendio, M, Ledda, S & Roldan, ER. (2008). *In vitro* oocyte maturation, fertilization and culture after ovum pick-up in an endangered gazelle (*Gazella dama mhorr*). *Theriogenology* 69, 3, 349-359.
- Bilton, RJ & Moore, NW. (1976). *In vitro* culture, storage and transfer of goat embryos. *Australian Journal of Biological Sciences* 29, 1-2, 125-129.
- Blondin, P, Coenen, K, Guilbault, LA & Sirard, MA. (1996). Superovulation can reduce the developmental competence of bovine embryos. *Theriogenology* 46, 7, 1191-1203.

- Bosch, P, Hernandez-Fonseca, HJ, Miller, DM, Wininger, JD, Massey, JB, Lamb, SV & Brackett, BG. (2004). Development of antral follicles in cryopreserved cat ovarian tissue transplanted to immunodeficient mice. *Theriogenology* 61, 2-3, 581-594.
- Boutelle, S, Lenahan, K, Krisher, R, Bauman, KL, Asa, CS & Silber, S. (2011). Vitrification of oocytes from endangered Mexican gray wolves (*Canis lupus baileyi*). *Theriogenology* 75, 4, 647-654.
- Bowen, RA. (1977). Fertilization *in vitro* of feline ova by spermatozoa from the ductus deferens. *Biology of Reproduction* 17, 1, 144-147.
- Bravo, PW, Skidmore, JA & Zhao, XX. (2000). Reproductive aspects and storage of semen in Camelidae. *Animal Reproduction Science* 62, 1-3, 173-193.
- Breed, WG, Taggart, DA, Bradtke, V, Leigh, CM, Gameau, L & Carroll, J. (1994). Effect of cryopreservation on development and ultrastructure of preimplantation embryos from the dasyurid marsupial *Sminthopsis crassicaudata*. *Journal of Reproduction and Fertility* 100, 2, 429-438.
- Brinster, RL & Zimmermann, JW. (1994). Spermatogenesis following male germ-cell transplantation. *Proceedings of the National Academy of Sciences of the United States of America* 91, 24, 11298-11302.
- Bromer, JG & Patrizio, P. (2009). Fertility preservation: the rationale for cryopreservation of the whole ovary. *Seminars in Reproductive Medicine* 27, 6, 465-471.
- Buchanan, SS, Pyatt, DW & Carpenter, JF. (2010). Preservation of differentiation and clonogenic potential of human hematopoietic stem and progenitor cells during lyophilization and ambient storage. *PLoS One* 5, 9, e12518.
- Burrows, WH & Quinn, JP. (1937). The collection of spermatozoa from domestic fowl and turkey. *Poultry Science* 16, 1, 19-24.
- Cabrita, E, Robles, V, Wallace, JC, Sarasquete, MC & Herráez, MP. (2006). Preliminary studies on the cryopreservation of gilthead seabream (*Sparus aurata*) embryos. *Aquaculture* 251, 2-4, 245-255.
- Cai, XY, Chen, GA, Lian, Y, Zheng, XY & Peng, HM. (2005). Cryoloop vitrification of rabbit oocytes. *Human Reproduction* 20, 7, 1969-1974.
- Callebaut, M. (1973). Correlation between germinal vesicle and oocyte development in the adult Japanese quail (*Coturnix coturnix japonica*). A cytochemical and autoradiographic study. *Journal of Embryology and Experimental Morphology* 29, 1, 145-157.
- Campbell, KH, McWhir, J, Ritchie, WA & Wilmut, I. (1996). Sheep cloned by nuclear transfer from a cultured cell line. *Nature* 380, 6569, 64-66.
- Campion, SN, Cappon, GD, Chapin, RE, Jamon, RT, Winton, TR & Nowland, WS. (2012). Isoflurane reduces motile sperm counts in the Sprague-Dawley rat. *Drug and Chemical Toxicology* 35, 1, 20-24.
- Candy, CJ, Wood, MJ & Whittingham, DG. (1995). Ovary and ovulation: Follicular development in cryopreserved marmoset ovarian tissue after transplantation. *Human Reproduction* 10, 9, 2334-2338.
- Candy, CJ, Wood, MJ & Whittingham, DG. (1997). Effect of cryoprotectants on the survival of follicles in frozen mouse ovaries. *Journal of Reproduction and Fertility* 110, 1, 11-19.
- Carroll, J & Gosden, RG. (1993). Transplantation of frozen-thawed mouse primordial follicles. *Human Reproduction* 8, 8, 1163-1167.

- Carroll, J, Whittingham, DG, Wood, MJ, Telfer, E & Gosden, RG. (1990). Extra-ovarian production of mature viable mouse oocytes from frozen primary follicles. *Journal of Reproduction and Fertility* 90, 1, 321-327.
- Ceballos, G & Ehrlich, PR. (2002). Mammal population losses and the extinction crisis. *Science* 296, 5569, 904-907.
- Chamayou, S, Bonaventura, G, Alecci, L, Tibullo, D, Di Raimondo, F, Guglielmino, A & Barcellona, ML. (2011). Consequences of metaphase II oocyte cryopreservation on mRNA content. *Cryobiology* 62, 2, 130-134.
- Chapin, FSI, Zavaleta, ES, Eviner, VT, Naylor, RL, Vitousek, PM, Reynolds, HL, Hooper, DU, Lavorel, S, Sala, OE, Hobbie, SE, Mack, MC & Diaz, S. (2000). Consequences of changing biodiversity. *Nature* 405, 6783, 234-242.
- Chastant-Maillard, S, Viaris de Lesegno, C, Chebrou, M, Thoumire, S, Meylheuc, T, Fontbonne, A, Chodkiewicz, M, Saint-Dizier, M & Reynaud, K. (2011). The canine oocyte: uncommon features of *in vivo* and *in vitro* maturation. *Reproduction, Fertility and Development* 23, 3, 391-402.
- Chen, C. (1986). Pregnancy after human oocyte cryopreservation. *Lancet* 1, 8486, 884-886.
- Chen, LM, Hou, R, Zhang, ZH, Wang, JS, An, XR, Chen, YF, Zheng, HP, Xia, GL & Zhang, MJ. (2007). Electroejaculation and semen characteristics of Asiatic black bears (*Ursus thibetanus*). *Animal Reproduction Science* 101, 3-4, 358-364.
- Chen, S-U & Yang, Y-S. (2009). Slow freezing or vitrification of oocytes: Their effects on survival and meiotic spindles, and the time schedule for clinical practice. *Taiwanese Journal of Obstetrics and Gynecology* 48, 1, 15-22.
- Chen, SL & Tian, YS. (2005). Cryopreservation of flounder (*Paralichthys olivaceus*) embryos by vitrification. *Theriogenology* 63, 4, 1207-1219.
- Chesne, P, Adenot, PG, Viglietta, C, Baratte, M, Boulanger, L & Renard, JP. (2002). Cloned rabbits produced by nuclear transfer from adult somatic cells. *Nature Biotechnology* 20, 4, 366-369.
- Cheung, H-H & Rennert, OM. (2011). Generation of fertile sperm in a culture dish: clinical implications. *Asian Journal of Andrology* 13, 4, 618-619.
- Choi, YH, Hartman, DL, Bliss, SB, Hayden, SS, Blanchard, TL & Hinrichs, K. (2009). High pregnancy rates after transfer of large equine blastocysts collapsed via micromanipulation before vitrification. *Reproduction, Fertility and Development* 22, 1, 203 (abstract).
- Choi, YH, Varner, DD, Love, CC, Hartman, DL & Hinrichs, K. (2011). Production of live foals via intracytoplasmic injection of lyophilized sperm and sperm extract in the horse. *Reproduction* 142, 4, 529-538.
- Christensen, BW, Asa, CS, Wang, C, Vansandt, L, Bauman, K, Callahan, M, Jens, JK & Ellinwood, NM. (2011). Effect of semen collection method on sperm motility of gray wolves (*Canis lupus*) and domestic dogs (*C. l. familiaris*). *Theriogenology* 76, 5, 975-980.
- Cibelli, JB, Stice, SL, Golueke, PJ, Kane, JJ, Jerry, J, Blackwell, C, Ponce de Leon, FA & Robl, JM. (1998). Cloned transgenic calves produced from nonquiescent fetal fibroblasts. *Science* 280, 5367, 1256-1258.
- Ciotti, PM, Porcu, E, Notarangelo, L, Magrini, O, Bazzocchi, A & Venturoli, S. (2009). Meiotic spindle recovery is faster in vitrification of human oocytes compared to slow freezing. *Fertility and Sterility* 91, 6, 2399-2407.

- Clarke, AG. (2009). The Frozen Ark Project: the role of zoos and aquariums in preserving the genetic material of threatened animals. *International Zoo Yearbook* 43, 1, 222-230.
- Cleary, M, Paris, MC, Shaw, J, Jenkin, G & Trounson, A. (2003). Effect of ovariectomy and graft position on cryopreserved common wombat (*Vombatus ursinus*) ovarian tissue following xenografting to nude mice. *Reproduction Fertility and Development* 15, 6, 333-342.
- Cleary, M, Snow, M, Paris, M, Shaw, J, Cox, SL & Jenkin, G. (2001). Cryopreservation of mouse ovarian tissue following prolonged exposure to an ischemic environment. *Cryobiology* 42, 2, 121-33.
- Cohen, J & Garrisi, GJ. (1997). Micromanipulation of gametes and embryos: Cryopreservation of a single human spermatozoon within an isolated zona pellucida. *Human Reproduction Update* 3, 5, 453.
- Cohen, J, Garrisi, GJ, Congedo-Ferrara, TA, Kieck, KA, Schimmel, TW & Scott, RT. (1997). Cryopreservation of single human spermatozoa. *Human Reproduction* 12, 5, 994-1001.
- Combelles, CMH & Racowsky, C. (2005). Assessment and optimization of oocyte quality during assisted reproductive technology treatment. *Seminars in Reproductive Medicine* 23, 3, 277-284.
- Comizzoli, P, Wildt, DE & Pukazhenth, BS. (2003). Overcoming poor *in vitro* nuclear maturation and developmental competence of domestic cat oocytes during the non-breeding season. *Reproduction* 126, 6, 809-816.
- Concannon, PW. (2011). Reproductive cycles of the domestic bitch. *Animal Reproduction Science* 124, 3-4, 200-210.
- Contri, A, De Amicis, I, Veronesi, MC, Faustini, M, Robbe, D & Carluccio, A. (2010). Efficiency of different extenders on cooled semen collected during long and short day length seasons in Martina Franca donkey. *Animal Reproduction Science* 120, 1-4, 136-141.
- Convention on Biological Diversity. Strategic Plan for the Convention on Biological Diversity. Decision VI/26 of the Conference of the Parties to the Convention on Biological Diversity. Accessed on 13 January, 2010, Available from: <<http://www.cbd.int/decision/cop/?id=7200>>.
- Corley-Smith, GE & Brandhorst, BP. (1999). Preservation of endangered species and populations: a role for genome banking, somatic cell cloning, and androgenesis? *Molecular Reproduction and Development* 53, 3, 363-367.
- Coticchio, G, Sereni, E, Serrao, L, Mazzone, S, Iadarola, I & Borini, A. (2004). What criteria for the definition of oocyte quality? *Annals of the New York Academy of Sciences* 1034, 132-144.
- Courbiere, B, Caquant, L, Mazoyer, C, Franck, M, Lornage, J & Salle, B. (2009). Difficulties improving ovarian functional recovery by microvascular transplantation and whole ovary vitrification. *Fertility and Sterility* 91, 6, 2697-2706.
- Cox, JL & Rizzino, A. (2010). Induced pluripotent stem cells: what lies beyond the paradigm shift. *Experimental Biology and Medicine* 235, 2, 148-158.
- Crabbe, E, Verheyen, G, Tournaye, H & Van Steirteghem, A. (1999). Freezing of testicular tissue as a minced suspension preserves sperm quality better than whole-biopsy freezing when glycerol is used as cryoprotectant. *International Journal of Andrology* 22, 1, 43-48.

- Cranfield, MR, Berger, NG, Kempeske, S, Bavister, BD, Boatman, DE & Ialeggio, DM. (1992). Macaque monkey birth following transfer of *in vitro* fertilized, frozen-thawed embryos to a surrogate mother. *Theriogenology* 37, 1, 197 (abstract).
- Criado, E, Albani, E, Novara, PV, Smeraldi, A, Cesana, A, Parini, V & Levi-Setti, PE. (2010). Human oocyte ultravitrification with a low concentration of cryoprotectants by ultrafast cooling: a new protocol. *Fertility and Sterility* 95, 3, 1101-1103.
- Crichton, EG, Armstrong, DL, Vajta, G, Pope, CE & Loskutoff, NM. (2000). Developmental competence *in vitro* of embryos produced from Siberian tigers (*Panthera tigris altaica*) cryopreserved by controlled rate freezing versus vitrification. *Theriogenology* 53, 1, 328 (abstract).
- Crichton, EG, Bedows, E, Miller-Lindholm, AK, Baldwin, DM, Armstrong, DL, Graham, LH, Ford, JJ, Gjorret, JO, Hyttel, P, Pope, CE, Vajta, G & Loskutoff, NM. (2003). Efficacy of porcine gonadotropins for repeated stimulation of ovarian activity for oocyte retrieval and *in vitro* embryo production and cryopreservation in Siberian tigers (*Panthera tigris altaica*). *Biology of Reproduction* 68, 1, 105-113.
- Cuello, C, Gil, MA, Parrilla, I, Tornel, J, Vázquez, JM, Roca, J, Berthelot, F, Martinat-Botté, F & Martínez, EA. (2004). Vitrification of porcine embryos at various developmental stages using different ultra-rapid cooling procedures. *Theriogenology* 62, 1-2, 353-361.
- Curnow, EC, Kuleshova, LL, Shaw, JM & Hayes, ES. (2002). Comparison of slow- and rapid-cooling protocols for early-cleavage-stage *Macaca fascicularis* embryos. *American Journal of Primatology* 58, 4, 169-174.
- Czarny, NA, Harris, MS, De Iuliis, GN & Rodger, JC. (2009a). Acrosomal integrity, viability, and DNA damage of sperm from dasyurid marsupials after freezing or freeze drying. *Theriogenology* 72, 6, 817-825.
- Czarny, NA, Harris, MS & Rodger, JC. (2009b). Dissociation and preservation of preantral follicles and immature oocytes from female dasyurid marsupials. *Reproduction, Fertility and Development* 21, 5, 640-648.
- Czarny, NA & Rodger, JC. (2010). Vitrification as a method for genome resource banking oocytes from the endangered Tasmanian devil (*Sarcophilus harrisii*). *Cryobiology* 60, 3, 322-325.
- Darwin, C. (1871). *The Descent of Man, and Selection in Relation to Sex*, D. Appleton and Company, New York.
- Das, ZC, Gupta, MK, Uhm, SJ & Lee, HT. (2010). Lyophilized somatic cells direct embryonic development after whole cell intracytoplasmic injection into pig oocytes. *Cryobiology* 61, 2, 220-224.
- de Queiroz, K. (2005). Ernst Mayr and the modern concept of species. *Proceedings of the National Academy of Sciences of the United States of America* 102, Suppl 1, 6600-6607.
- Devroey, P, Liu, J, Nagy, Z, Goossens, A, Tournaye, H, Camus, M, van Steirteghem, A & Silber, S. (1995). Pregnancies after testicular sperm extraction and intracytoplasmic sperm injection in non-obstructive azoospermia. *Human Reproduction* 10, 6, 1457-1460.
- Ding, FH, Xiao, ZZ & Li, J. (2007). Preliminary studies on the vitrification of red sea bream (*Pagrus major*) embryos. *Theriogenology* 68, 5, 702-708.
- Dixon, TE, Hunter, JW & Beatson, NS. (1991). Pregnancies following the export of frozen red deer embryos from New Zealand to Australia. *Theriogenology* 35, 1, 193 (Abstract).



- Dobrinsky, JR, Pursel, VG, Long, CR & Johnson, LA. (2000). Birth of piglets after transfer of embryos cryopreserved by cytoskeletal stabilization and vitrification. *Biology of Reproduction* 62, 3, 564-570.
- Donnez, J, Dolmans, MM, Demylle, D, Jadoul, P, Pirard, C, Squifflet, J, Martinez-Madrid, B & van Langendonck, A. (2004). Livebirth after orthotopic transplantation of cryopreserved ovarian tissue. *Lancet* 364, 9443, 1405-1410.
- Donoghue, AM, Johnston, LA, Seal, US, Armstrong, DL, Tilson, RL, Wolf, P, Petrini, K, Simmons, LG, Gross, T & Wildt, DE. (1990). *In vitro* fertilization and embryo development in vitro and *in vivo* in the tiger (*Panthera tigris*). *Biology of Reproduction* 43, 5, 733-744.
- Dresser, BL, Gelwicks, EJ, Wachs, KB & Keller, GL. (1988). First successful transfer of cryopreserved feline (*Felis catus*) embryos resulting in live offspring. *Journal of Experimental Zoology* 246, 2, 180-186.
- Dresser, BL, Kramer, L, Dalhausen, RD, Pope, CE & Baker, RD. (1984) Cryopreservation followed by successful embryo transfer of African eland antelope. *Proceedings of the 10th International Congress on Animal Reproduction and Artificial Insemination*, University of Illinois at Urbana-Champaign, Illinois, USA, June 10-14, 1984.
- Dresser, BL, Pope, CE, Kramer, L, Kuehn, G, Dahlhausen, RD, Maruska, EJ, Reece, B & Thomas, WD. (1985). Birth of bongo antelope (*Tragelaphus euryceros*) to eland antelope (*Tragelaphus oryx*) and cryopreservation of bongo embryos. *Theriogenology* 23, 1, 190 (abstract).
- Durrant, BS. (1983). Reproductive studies of the Oryx. *Zoo Biology* 2, 3, 191-197.
- Dziminski, MA, Roberts, JD, Beveridge, M & Simmons, LW. (2009). Sperm competitiveness in frogs: slow and steady wins the race. *Proceedings of the Royal Society B-Biological Sciences* 276, 1675, 3955-3961.
- Edgar, DH & Gook, DA. (2007). How should the clinical efficiency of oocyte cryopreservation be measured? *Reproduction Biomedicine Online* 14, 4, 430-435.
- Ehmcke, J & Schlatt, S. (2008). Animal models for fertility preservation in the male. *Reproduction* 136, 6, 717-723.
- Ehrlich, PR & Wilson, EO. (1991). Biodiversity studies: science and policy. *Science* 253, 5021, 758-762.
- Eppig, JJ & O'Brien, MJ. (1996). Development *in vitro* of mouse oocytes from primordial follicles. *Biology of Reproduction* 54, 1, 197-207.
- Erwin, DH. (2001). Lessons from the past: biotic recoveries from mass extinctions. *Proceedings of the National Academy of Science of the United States of America* 98, 10, 5399-5403.
- Escriba, M-J, Grau, N, Escrich, L & Pellicer, A. (2010). Vitrification of isolated human blastomeres. *Fertility and Sterility* 93, 2, 669-671.
- Fabbri, R, Porcu, E, Marsella, T, Primavera, MR, Rocchetta, G, Ciotti, PM, Magrini, O, Seracchioli, R, Venturoli, S & Flamigni, C. (2000). Technical aspects of oocyte cryopreservation. *Molecular and Cellular Endocrinology* 169, 1-2, 39-42.
- Fahy, GM, Saur, J & Williams, RJ. (1990). Physical problems with the vitrification of large biological systems. *Cryobiology* 27, 5, 492-510.
- Farstad, W. (2000a). Assisted reproductive technology in canid species. *Theriogenology* 53, 1, 175-186.

- Farstad, W. (2000b). Current state in biotechnology in canine and feline reproduction. *Animal Reproduction Science* 60-61, 375-387.
- Feng, L-X, Chen, Y, Dettin, L, Pera, RAR, Herr, JC, Goldberg, E & Dym, M. (2002). Generation and *in vitro* differentiation of a spermatogonial cell line. *Science* 297, 5580, 392-395.
- Ferdows, M, Moore, CL & Dracy, AE. (1958). Survival of rabbit ova stored as -79°C. *Journal of Dairy Science* 41, 5, 739 (abstract).
- Fisher, HS & Hoekstra, HE. (2010). Competition drives cooperation among closely related sperm of deer mice. *Nature* 463, 7282, 801-803.
- Foote, RH. (2000). Fertilizing ability of epididymal sperm from dead animals. *Journal of Andrology* 21, 3, 355.
- Fornari, DC, Ribeiro, RP, Streit, D, Godoy, LC, Neves, PR, de Oliveira, D & Sirol, RN. (2011). Effect of cryoprotectants on the survival of cascudo preto (*Rhinelepis aspera*) embryos stored at -8 degrees C. *Zygote* In Press, doi: 10.1017/S0967199411000517.
- Fujihira, T, Kobayashi, M, Hochi, S, Hirabayashi, M, Ishikawa, H, Ohsumi, S & Fukui, Y. (2006). Developmental capacity of Antarctic minke whale (*Balaenoptera bonaerensis*) vitrified oocytes following *in vitro* maturation, and parthenogenetic activation or intracytoplasmic sperm injection. *Zygote* 14, 2, 89-95.
- Galli, C, Lagutina, I, Crotti, G, Colleoni, S, Turini, P, Ponderato, N, Duchi, R & Lazzari, G. (2003). A cloned horse born to its dam twin. *Nature* 424, 635.
- Gandolfi, F, Paffoni, A, Papasso Brambilla, E, Bonetti, S, Brevini, TA & Ragni, G. (2006). Efficiency of equilibrium cooling and vitrification procedures for the cryopreservation of ovarian tissue: comparative analysis between human and animal models. *Fertility and Sterility* 85 Suppl 1, 1150-1156.
- Gastal, MO, Henry, M, Beker, AR, Gastal, EL & Goncalves, A. (1996). Sexual behavior of donkey jacks: Influence of ejaculatory frequency and season. *Theriogenology* 46, 4, 593-603.
- Gianaroli, L, Magli, MC, Selman, HA, Colpi, G, Belgrano, E, Trombetta, C, Vitali, G & Ferraretti, AP. (1999). Diagnostic testicular biopsy and cryopreservation of testicular tissue as an alternative to repeated surgical openings in the treatment of azoospermic men. *Human Reproduction* 14, 4, 1034-1038.
- Gibson, CD & Graham, EF. (1969). The relationship between fertility and post-freeze motility of bull spermatozoa (by pellet freezing) without glycerol. *Journal of Reproduction and Fertility* 20, 1, 155-157.
- Gil-Salom, M, Romero, J, Rubio, C, Ruiz, A, Remohí, J & Pellicer, A. (2000). Intracytoplasmic sperm injection with cryopreserved testicular spermatozoa. *Molecular and Cellular Endocrinology* 169, 1-2, 15-19.
- Gohbara, A, Katagiri, K, Sato, T, Kubota, Y, Kagechika, H, Araki, Y, Araki, Y & Ogawa, T. (2010). *In vitro* murine spermatogenesis in an organ culture system. *Biology of Reproduction* 83, 2, 261-267.
- Gomendio, M, Cassinello, J & Roldan, ERS. (2000). A comparative study of ejaculate traits in three endangered ungulates with different levels of inbreeding: fluctuating asymmetry as an indicator of reproductive and genetic stress. *Proceedings of the Royal Society of London. Series B: Biological Sciences* 267, 1446, 875-882.

- Gómez, MC, Jenkins, JA, Giraldo, A, Harris, RF, King, A, Dresser, BL & Pope, CE. (2003). Nuclear transfer of synchronized African wild cat somatic cells into enucleated domestic cat oocytes. *Biology of Reproduction* 69, 3, 1032-1041.
- Gómez, MC, Lyons, JI, Pope, CE, Biancardi, M, Dumas, C, Galiguis, J, Wang, G & Dresser, BL. (2009). Effects of phylogenetic genera of recipient cytoplasts on development and viability of Canada lynx (*Lynx canadensis*) cloned embryos. *Reproduction, Fertility and Development* 22, 1, 186 (abstract).
- Gómez, MC, Pope, CE, Kutner, RH, Ricks, DM, Lyons, LA, Ruhe, M, Dumas, C, Lyons, J, Lopez, M, Dresser, BL & Reiser, J. (2008). Nuclear transfer of sand cat cells into enucleated domestic cat oocytes is affected by cryopreservation of donor cells. *Cloning and Stem Cells* 10, 4, 469-483.
- Goodrowe, KL, Miller, AM & Wildt, DE. (1989). *In vitro* fertilization of gonadotropin-stimulated leopard cat (*Felis bengalensis*) follicular oocytes. *Journal of Experimental Zoology* 252, 1, 89-95.
- Goodrowe, KL, Wall, RJ, O'Brien, SJ, Schmidt, PM & Wildt, DE. (1988). Developmental competence of domestic cat follicular oocytes after fertilization *in vitro*. *Biology of Reproduction* 39, 2, 355-372.
- Gook, DA, Edgar, DH, Borg, J, Archer, J, Lutjen, PJ & McBain, JC. (2003). Oocyte maturation, follicle rupture and luteinization in human cryopreserved ovarian tissue following xenografting. *Human Reproduction* 18, 9, 1772-1781.
- Gook, DA, McCully, BA, Edgar, DH & McBain, JC. (2001). Development of antral follicles in human cryopreserved ovarian tissue following xenografting. *Human Reproduction* 16, 3, 417-422.
- Gook, DA, Osborn, SM & Johnston, WIH. (1993). Cryopreservation of mouse and human oocytes using 1, 2-propanediol and the configuration of the meiotic spindle. *Human Reproduction* 8, 7, 1101-1109.
- Gosden, RG, Boulton, MI, Grant, K & Webb, R. (1994). Follicular development from ovarian xenografts in SCID mice. *Journal of Reproduction and Fertility* 101, 3, 619-623.
- Guenther, JF, Seki, S, Kleinhans, FW, Edashige, K, Roberts, DM & Mazur, P. (2006). Extra- and intra-cellular ice formation in Stage I and II *Xenopus laevis* oocytes. *Cryobiology* 52, 3, 401-416.
- Gunasena, KT, Lakey, JRT, Villines, PM, Bush, M, Raath, C, Critser, ES, McGann, LE & Critser, JK. (1998). Antral follicles develop in xenografted cryopreserved African elephant (*Loxodonta africana*) ovarian tissue. *Animal Reproduction Science* 53, 1-4, 265-275.
- Gupta, MK, Uhm, SJ & Lee, HT. (2010). Effect of vitrification and beta-mercaptoethanol on reactive oxygen species activity and *in vitro* development of oocytes vitrified before or after *in vitro* fertilization. *Fertility and Sterility* 93, 8, 2602-2607.
- Gvakharia, M & Adamson, GD. (2001). A method of successful cryopreservation of small numbers of human spermatozoa. *Fertility and Sterility* 76, 3, Supplement 1, S101 (Abstract).
- Hagedorn, M, Hsu, E, Kleinhans, FW & Wildt, DE. (1997a). New approaches for studying the permeability of fish embryos: Toward successful cryopreservation. *Cryobiology* 34, 4, 335-347.
- Hagedorn, M, Hsu, EW, Pilatus, U, Wildt, DE, Rall, WR & Blackband, SJ. (1996). Magnetic resonance microscopy and spectroscopy reveal kinetics of cryoprotectant

- permeation in a multicompartmental biological system. *Proceedings of the National Academy of Science of the United States of America* 93, 15, 7454-7459.
- Hagedorn, M, Kleinhans, FW, Freitas, R, Liu, J, Hsu, EW, Wildt, DE & Rall, WF. (1997b). Water distribution and permeability of zebrafish embryos, *Brachydanio rerio*. *Journal of Experimental Zoology* 278, 6, 356-371.
- Hagedorn, M, Kleinhans, FW, Wildt, DE & Rall, WF. (1997c). Chill sensitivity and cryoprotectant permeability of dechorionated zebrafish embryos, *Brachydanio rerio*. *Cryobiology* 34, 3, 251-263.
- Hagedorn, M, Lance, SL, Fonseca, DM, Kleinhans, FW, Artimov, D, Fleischer, R, Hoque, AT, Hamilton, MB & Pukazhenth, BS. (2002). Altering fish embryos with aquaporin-3: an essential step toward successful cryopreservation. *Biology of Reproduction* 67, 3, 961-966.
- Harvey, B. (1983). Cooling of embryonic cells, isolated blastoderms, and intact embryos of the zebra fish *Brachydanio rerio* to  $-196^{\circ}\text{C}$ . *Cryobiology* 20, 4, 440-447.
- Hayashi, S, Kobayashi, K, Mizuno, J, Saitoh, K & Hirano, S. (1989). Birth of piglets from frozen embryos. *The Veterinary Record* 125, 2, 43-44.
- He, X, Park, EYH, Fowler, A, Yarmush, ML & Toner, M. (2008). Vitrification by ultra-fast cooling at a low concentration of cryoprotectants in a quartz micro-capillary: A study using murine embryonic stem cells. *Cryobiology* 56, 3, 223-232.
- Hearn, JP & Summers, PM. (1986). Experimental manipulation of embryo implantation in the marmoset monkey and exotic equids. *Theriogenology* 25, 1, 3-11.
- Hermes, R, Behr, B, Hildebrandt, TB, Blottner, S, Sieg, B, Frenzel, A, Knieriem, A, Saragusty, J & Rath, D. (2009a). Sperm sex-sorting in the Asian elephant (*Elephas maximus*). *Animal Reproduction Science* 112, 3-4, 390-396.
- Hermes, R, Göritz, F, Saragusty, J, Sos, E, Molnar, V, Reid, CE, Schwarzenberger, F & Hildebrandt, TB. (2009b). First successful artificial insemination with frozen-thawed semen in rhinoceros. *Theriogenology* 71, 3, 393-399.
- Herrera, C, Conde, P, Donaldson, M, Quintans, C, Cortvrindt, R & de Matos, DG. (2002). Bovine follicular development up to antral stages after frozen-thawed ovarian tissue transplantation into nude mice. *Theriogenology* 57, 1, 608 (abstract).
- Herrick, JR, Campbell, M, Levens, G, Moore, T, Benson, K, D'Agostino, J, West, G, Okeson, DM, Coke, R, Portacio, SC, Leiske, K, Kreider, C, Polumbo, PJ & Swanson, WF. (2010). *In vitro* fertilization and sperm cryopreservation in the black-footed cat (*Felis nigripes*) and sand cat (*Felis margarita*). *Biology of Reproduction* 82, 3, 552-562.
- Herrler, A, Eisner, S, Bach, V, Weissenborn, U & Beier, HM. (2006). Cryopreservation of spermatozoa in alginate acid capsules. *Fertility and Sterility* 85, 1, 208-213.
- Hewitson, L, Martinovich, C, Simerly, C, Takahashi, D & Schatten, G. (2002). Rhesus offspring produced by intracytoplasmic injection of testicular sperm and elongated spermatids. *Fertility and Sterility* 77, 4, 794-801.
- Higaki, S, Eto, Y, Kawakami, Y, Yamaha, E, Kagawa, N, Kuwayama, M, Nagano, M, Katagiri, S & Takahashi, Y. (2010). Production of fertile zebrafish (*Danio rerio*) possessing germ cells (gametes) originated from primordial germ cells recovered from vitrified embryos. *Reproduction* 139, 4, 733-740.
- Hildebrandt, TB, Hermes, R, Jewgenow, K & Göritz, F. (2000). Ultrasonography as an important tool for the development and application of reproductive technologies in non-domestic species. *Theriogenology* 53, 1, 73-84.

- Hildebrandt, TB, Roellig, K, Goeritz, F, Fassbender, M, Krieg, R, Blottner, S, Behr, B & Hermes, R. (2009). Artificial insemination of captive European brown hares (*Lepus europaeus* PALLAS, 1778) with fresh and cryopreserved semen derived from free-ranging males. *Theriogenology* 72, 8, 1065-1072.
- Hirabayashi, M, Kato, M & Hochi, S. (2008). Factors affecting full-term development of rat oocytes microinjected with fresh or cryopreserved round spermatids. *Experimental Animals* 57, 4, 401-405.
- Hirabayashi, M, Kato, M, Ito, J & Hochi, S. (2005). Viable rat offspring derived from oocytes intracytoplasmically injected with freeze-dried sperm heads. *Zygote* 13, 1, 79-85.
- Hishinuma, M, Suzuki, K & Sekine, J. (2003). Recovery and cryopreservation of Sika deer (*Cervus nippon*) spermatozoa from epididymides stored at 4°C. *Theriogenology* 59, 3-4, 813-820.
- Hochi, S, Watanabe, K, Kato, M & Hirabayashi, M. (2008). Live rats resulting from injection of oocytes with spermatozoa freeze-dried and stored for one year. *Molecular Reproduction and Development* 75, 5, 890-894.
- Hollinshead, FK, O'Brien, JK, Maxwell, WM & Evans, G. (2004). Assessment of *in vitro* sperm characteristics after flow cytometric sorting of frozen-thawed bull spermatozoa. *Theriogenology* 62, 5, 958-968.
- Holt, WV. (2001). Germplasm Cryopreservation in Elephants and Wild Ungulates. In: *Cryobanking the Genetic Resource: Wildlife Conservation for the Future*, Watson, PF, Holt, WV, editors, p 317-348, Taylor & Francis, New York.
- Holt, WV. (2011). Mechanisms of sperm storage in the female reproductive tract: an interspecies comparison. *Reproduction in Domestic Animals* 46, Suppl. S2, 68-74.
- Holt, WV & Lloyd, RE. (2010). Sperm storage in the vertebrate female reproductive tract: How does it work so well? *Theriogenology* 73, 6, 713-722.
- Honaramooz, A, Behboodi, E, Blash, S, Megee, SO & Dobrinski, I. (2003a). Germ cell transplantation in goats. *Molecular Reproduction and Development* 64, 4, 422-428.
- Honaramooz, A, Behboodi, E, Megee, SO, Overton, SA, Galantino-Homer, H, Echelard, Y & Dobrinski, I. (2003b). Fertility and germline transmission of donor haplotype following germ cell transplantation in immunocompetent goats. *Biology of Reproduction* 69, 4, 1260-1264.
- Honaramooz, A, Li, MW, Penedo, MC, Meyers, S & Dobrinski, I. (2004). Accelerated maturation of primate testis by xenografting into mice. *Biology of Reproduction* 70, 5, 1500-1503.
- Honaramooz, A, Megee, SO & Dobrinski, I. (2002). Germ cell transplantation in pigs. *Biology of Reproduction* 66, 1, 21-28.
- Hong, Y, Liu, T, Zhao, H, Xu, H, Wang, W, Liu, R, Chen, T, Deng, J & Gui, J. (2004). Establishment of a normal medakafish spermatogonial cell line capable of sperm production *in vitro*. *Proceedings of the National Academy of Science of the United States of America* 101, 21, 8011-8016.
- Hoshina, M, Furugaichi, A, Kuji, N, Ito, J & Kashiwazaki, N. (2009). Vitrification of whole ovaries in young rats. *Reproduction, Fertility and Development* 22, 1, 206 (abstract).
- Hoshino, Y, Hayashi, N, Taniguchi, S, Kobayashi, N, Sakai, K, Otani, T, Iritani, A & Saeki, K. (2009). Resurrection of a bull by cloning from organs frozen without cryoprotectant in a -80 degrees c freezer for a decade. *PLoS One* 4, 1, e4142.

- Hovatta, O, Foudila, T, Siegberg, R, Johansson, K, von Smitten, K & Reima, I. (1996). Pregnancy resulting from intracytoplasmic injection of spermatozoa from a frozen-thawed testicular biopsy specimen. *Human Reproduction* 11, 2472-2473.
- Howell-Stephens, JA, Brown, J, Santymire, R, Bernier, D & Mulkerin, D. (2009) Using giving-up densities and adrenocortical activity to determine the state of Southern three-banded armadillos (*Tolypeutes matacus*) housed in North America. *10th International Mammalogical Congress, Mendoza, Argentina, 9-14.8.2009*.
- Hunter, P. (2011). To protect and save. *EMBO Reports* 12, 3, 205-207.
- Ikeda, H, Kikuchi, K, Noguchi, J, Takeda, H, Shimada, A, Mizokami, T & Kaneko, H. (2002). Effect of preincubation of cryopreserved porcine epididymal sperm. *Theriogenology* 57, 4, 1309-1318.
- Imhof, M, Hofstetter, G, Bergmeister, H, Rudas, M, Kain, R, Lipovac, M & Huber, J. (2004). Cryopreservation of a whole ovary as a strategy for restoring ovarian function. *Journal of Assisted Reproduction and Genetics* 21, 12, 459-465.
- Isachenko, E, Isachenko, V, Katkov, II, Dessole, S & Nawroth, F. (2003). Vitrification of mammalian spermatozoa in the absence of cryoprotectants: from past practical difficulties to present success. *Reproductive Biomedicine Online* 6, 2, 191-200.
- Isachenko, V, Alabart, JL, Nawroth, F, Isachenko, E, Vajta, G & Folch, J. (2001). The open pulled straw vitrification of ovine GV-oocytes: positive effect of rapid cooling or rapid thawing or both? *Cryo Letters* 22, 3, 157-162.
- Isachenko, V, Isachenko, E, Katkov, II, Montag, M, Dessole, S, Nawroth, F & van der Ven, H. (2004). Cryoprotectant-free cryopreservation of human spermatozoa by vitrification and freezing in vapor: Effect on motility, DNA integrity, and fertilization ability. *Biology of Reproduction* 71, 4, 1167-1173.
- Isachenko, V, Lapidus, I, Isachenko, E, Krivokharchenko, A, Kreienberg, R, Woriedh, M, Bader, M & Weiss, JM. (2009). Human ovarian tissue vitrification versus conventional freezing: morphological, endocrinological, and molecular biological evaluation. *Reproduction* 138, 2, 319-327.
- Isaev, DA, Zaletov, SY, Zaeva, VV, Zakharova, EE, Shafei, RA & Krivokharchenko, IS. (2007). Artificial microcontainers for cryopreservation of solitary spermatozoa. *Human Reproduction* 22, suppl 1, i154-i155 (abstract).
- Ishijima, T, Kobayashi, Y, Lee, D-S, Ueta, YY, Matsui, M, Lee, J-Y, Suwa, Y, Miyahara, K & Suzuki, H. (2006). Cryopreservation of canine ovaries by vitrification. *The Journal of Reproduction and Development* 52, 2, 293-299.
- IUCN. IUCN Red List of Threatened Species. Accessed on August 6, 2007, Available from: <<http://www.iucnredlist.org>>.
- IUCN. IUCN Red List of Threatened Species. Version 2010.4. Accessed on 31 December, 2010, Available from: <<http://www.iucnredlist.org/>>.
- Iwayama, H, Hochi, S, Kato, M, Hirabayashi, M, Kuwayama, M, Ishikawa, H, Ohsumi, S & Fukui, Y. (2005). Effects of cryodevice type and donors' sexual maturity on vitrification of minke whale (*Balaenoptera bonaerensis*) oocytes at germinal vesicle stage. *Zygote* 12, 4, 333-338.
- Izadyar, F, Den Ouden, K, Stout, TA, Stout, J, Coret, J, Lankveld, DP, Spoormakers, TJ, Colenbrander, B, Oldenbroek, JK, Van der Ploeg, KD, Woelders, H, Kal, HB & De Rooij, DG. (2003). Autologous and homologous transplantation of bovine spermatogonial stem cells. *Reproduction* 126, 6, 765-774.

- Jackowski, S, Leibo, SP & Mazur, P. (1980). Glycerol permeabilities of fertilized and unfertilized mouse ova. *Journal of Experimental Zoology* 212, 3, 329-341.
- Jang, G, Kim, MK, Oh, HJ, Hossein, MS, Fibrianto, YH, Hong, SG, Park, JE, Kim, JJ, Kim, HJ, Kang, SK, Kim, DY & Lee, BC. (2007). Birth of viable female dogs produced by somatic cell nuclear transfer. *Theriogenology* 67, 5, 941-947.
- Janik, M, Kleinhans, FW & Hagedorn, M. (2000). Overcoming a permeability barrier by microinjecting cryoprotectants into zebrafish embryos (*Brachydanio rerio*). *Cryobiology* 41, 1, 25-34.
- Jewgenow, K, Blottner, S, Goritz, F, Hildebrandt, T, Hingst, O, Lengwinat, T, Lucker, H & Schneider, HE. (1994). Application of assisted reproductive technology in puma (*Felis concolor*). *Erkrankungen der Zootiere* 36, 59-65.
- Jewgenow, K, Blottner, S, Lengwinat, T & Meyer, HH. (1997). New methods for gamete rescue from gonads of nondomestic felids. *Journal of Reproduction and Fertility, supplement* 51, 33-39.
- Jewgenow, K & Paris, MC. (2006). Preservation of female germ cells from ovaries of cat species. *Theriogenology* 66, 1, 93-100.
- Jewgenow, K, Penfold, LM, Meyer, HHD & Wildt, DE. (1998). Viability of small preantral ovarian follicles from domestic cats after cryoprotectant exposure and cryopreservation. *Journal of Reproduction and Fertility* 112, 1, 39-47.
- Jewgenow, K, Wiedemann, C, Bertelsen, MF & Ringleb, J. (2011). Cryopreservation of mammalian ovaries and oocytes. *International Zoo Yearbook* 45, 124-132.
- Jin, B, Kawai, Y, Hara, T, Takeda, S, Seki, S, Nakata, Y-i, Matsukawa, K, Koshimoto, C, Kasai, M & Edashige, K. (2011). Pathway for the movement of water and cryoprotectants in bovine oocytes and embryos. *Biology of Reproduction* 85, 4, 834-847.
- Johnson, LA, Flook, JP & Look, MV. (1987a). Flow cytometry of X and Y chromosome-bearing sperm for DNA using an improved preparation method and staining with Hoechst 33342. *Gamete Research* 17, 3, 203-212.
- Johnson, LA, Flook, JP, Look, MV & Pinkel, D. (1987b). Flow sorting of X and Y chromosome-bearing spermatozoa into two populations. *Gamete Research* 16, 1, 1-9.
- Johnson, MH, Pickering, SJ & George, MA. (1988). The influence of cooling on the properties of the zona pellucida of the mouse oocyte. *Human Reproduction* 3, 3, 383-387.
- Johnston, LA, Donoghue, AM, O'Brien, SJ & Wildt, DE. (1991). Rescue and maturation *in vitro* of follicular oocytes collected from nondomestic felid species. *Biology of Reproduction* 45, 6, 898-906.
- Johnston, SD, McGowan, MR, Carrick, FN & Tribe, A. (1993). Preliminary investigations into the feasibility of freezing koala (*Phascolarctos cinereus*) semen. *Australian Veterinary Journal* 70, 11, 424-425.
- Just, A, Gruber, I, Wöber, M, Lahodny, J, Obruca, A & Strohmer, H. (2004). Novel method for the cryopreservation of testicular sperm and ejaculated spermatozoa from patients with severe oligospermia: A pilot study. *Fertility and Sterility* 82, 2, 445-447.
- Kagawa, N, Silber, S & Kuwayama, M. (2009). Successful vitrification of bovine and human ovarian tissue. *Reproductive Biomedicine Online* 18, 4, 568-577.
- Kalicharan, D, Jongebloed, WL, Rawson, DM & Zhang, T. (1998). Variations in fixation techniques for field emission SEM and TEM of zebrafish (*Branchydanio rerio*)

- embryo inner and outer membranes. *Journal of Electron Microscopy (Tokyo)* 47, 6, 645-658.
- Kaneko, T & Nakagata, N. (2005). Relation between storage temperature and fertilizing ability of freeze-dried mouse spermatozoa. *Comparative Medicine* 55, 2, 140-144.
- Kaneko, T, Whittingham, DG & Yanagimachi, R. (2003). Effect of pH value of freeze-drying solution on the chromosome integrity and developmental ability of mouse spermatozoa. *Biology of Reproduction* 68, 1, 136-139.
- Kang, SJ, Choi, JW, Kim, SY, Park, KJ, Kim, TM, Lee, YM, Kim, H, Lim, JM & Han, JY. (2008). Reproduction of wild birds via interspecies germ cell transplantation. *Biology of Reproduction* 79, 5, 931-937.
- Kanno, H, Saito, K, Ogawa, T, Takeda, M, Iwasaki, A & Kinoshita, Y. (1998). Viability and function of human sperm in electrolyte-free cold preservation. *Fertility and Sterility* 69, 1, 127-131.
- Kasai, M, Iritani, A & Chang, MC. (1979). Fertilization *in vitro* of rat ovarian oocytes after freezing and thawing. *Biology of Reproduction* 21, 4, 839-844.
- Kasiraj, R, Misra, AK, Mutha Rao, M, Jaiswal, RS & Rangareddi, NS. (1993). Successful culmination of pregnancy and live birth following the transfer of frozen-thawed buffalo embryos. *Theriogenology* 39, 5, 1187-1192.
- Katayose, H, Matsuda, J & Yanagimachi, R. (1992). The ability of dehydrated hamster and human sperm nuclei to develop into pronuclei. *Biology of Reproduction* 47, 2, 277-284.
- Katkov, II, Isachenko, V, Isachenko, E, Kim, MS, Lulat, AGMI, Mackay, AM & Levine, F. (2006). Low- and high-temperature vitrification as a new approach to biostabilization of reproductive and progenitor cells. *International Journal of Refrigeration* 29, 3, 346-357.
- Kato, H, Anzai, M, Mitani, T, Morita, M, Nishiyama, Y, Nakao, A, Kondo, K, Lazarev, PA, Ohtani, T, Shibata, Y & Iritani, A. (2009). Recovery of cell nuclei from 15,000-year-old mammoth tissue and injection into mouse enucleated matured oocytes. *Reproduction, Fertility and Development* 22, 1, 189 (abstract).
- Kawakami, Y, Goto-Kazeto, R, Saito, T, Fujimoto, T, Higaki, S, Takahashi, Y, Arai, K & Yamaha, E. (2010). Generation of germ-line chimera zebrafish using primordial germ cells isolated from cultured blastomeres and cryopreserved embryoids. *International Journal of Developmental Biology* 54, 10, 1493-1501.
- Keeley, T, McGreevy, PD & O'Brien, JK. (2011). Characterization and short-term storage of Tasmanian devil sperm collected post-mortem. *Theriogenology* 76, 4, 705-714.
- Keskintepe, L, Pacholczyk, G, Machnicka, A, Norris, K, Curuk, MA, Khan, I & Brackett, BG. (2002). Bovine blastocyst development from oocytes injected with freeze-dried spermatozoa. *Biology of Reproduction* 67, 2, 409-415.
- Kikuchi, K, Nagai, T, Kashiwazaki, N, Ikeda, H, Noguchi, J, Shimada, A, Soloy, E & Kaneko, H. (1998). Cryopreservation and ensuing *in vitro* fertilization ability of boar spermatozoa from epididymides stored at 4°C. *Theriogenology* 50, 4, 615-623.
- Kim, MK, Jang, G, Oh, HJ, Yuda, F, Kim, HJ, Hwang, WS, Hossein, MS, Kim, JJ, Shin, NS, Kang, SK & Lee, BC. (2007). Endangered wolves cloned from adult somatic cells. *Cloning and Stem Cells* 9, 1, 130-137.



- Kim, SS, Kang, HG, Kim, NH, Lee, HC & Lee, HH. (2005). Assessment of the integrity of human oocytes retrieved from cryopreserved ovarian tissue after xenotransplantation. *Human Reproduction* 20, 9, 2502-2508.
- Kimura, Y & Yanagimachi, R. (1995). Mouse oocytes injected with testicular spermatozoa or round spermatids can develop into normal offspring. *Development* 121, 8, 2397-2405.
- Kleinhans, FW, Guenther, JF, Roberts, DM & Mazur, P. (2006). Analysis of intracellular ice nucleation in *Xenopus* oocytes by differential scanning calorimetry. *Cryobiology* 52, 1, 128-138.
- Klooster, KL, Burruel, VR & Meyers, SA. (2011). Loss of fertilization potential of desiccated rhesus macaque spermatozoa following prolonged storage. *Cryobiology* 62, 3, 161-166.
- Koh, LP, Dunn, RR, Sodhi, NS, Colwell, RK, Proctor, HC & Smith, VS. (2004). Species coextinctions and the biodiversity crisis. *Science* 305, 5690, 1632-1634.
- Kohara, Y, Kanai, Y & Tajima, A. (2008). Cryopreservation of gonadal germ cells (GGCs) from the domestic chicken using vitrification. *The Journal of Poultry Science* 45, 1, 57-61.
- Kono, T, Suzuki, O & Tsunoda, Y. (1988). Cryopreservation of rat blastocysts by vitrification. *Cryobiology* 25, 2, 170-173.
- Koscinski, I, Wittmer, C, Lefebvre-Khalil, V, Marcelli, F, Defosse, A & Rigot, JM. (2007). Optimal management of extreme oligozoospermia by an appropriate cryopreservation programme. *Human Reproduction* 22, 10, 2679-2684.
- Kramer, L, Dresser, BL, Pope, CE, Dalhausen, RD & Baker, RD. (1983) The non-surgical transfer of frozen-thawed eland (*Tragelaphus oryx*) embryos. *Annual Proceedings of the American Association of Zoo Veterinarians*, Tampa, Florida, USA, October 24-27, 1983.
- Krisher, RL. (2004). The effect of oocyte quality on development. *Journal of Animal Science* 82, 13\_suppl, E14-E23.
- Krzywinski, A. (1981). Freezing of post-mortem collected semen from moose and red deer. *Acta Theriologica* 26, 424-426.
- Kusakabe, H & Tateno, H. (2011). Characterization of chromosomal damage accumulated in freeze-dried mouse spermatozoa preserved under ambient and heat stress conditions. *Mutagenesis* 26, 3, 447-453.
- Kusakabe, H, Yanagimachi, R & Kamiguchi, Y. (2008). Mouse and human spermatozoa can be freeze-dried without damaging their chromosomes. *Human Reproduction* 23, 2, 233-239.
- Kwon, IK, Park, KE & Niwa, K. (2004). Activation, pronuclear formation, and development *in vitro* of pig oocytes following intracytoplasmic injection of freeze-dried spermatozoa. *Biology of Reproduction* 71, 5, 1430-1436.
- Kyriakopoulou-Sklavounou, P & Loumbourdis, N. (1990). Annual ovarian cycle in the frog, *Rana ridibunda*, in northern Greece. *Journal of Herpetology* 24, 2, 185-191.
- Landa, CA & Almquist, JO. (1979). Effect of freezing large numbers of straws of bovine spermatozoa in an automatic freezer on post-thaw motility and acrosomal retention. *Journal of Animal Science* 49, 5, 1190-1194.
- Lane, M, Forest, KT, Lyons, EA & Bavister, BD. (1999). Live births following vitrification of hamster embryos using a novel containerless technique. *Theriogenology* 51, 1, 167 (abstract).

- Lanza, RP, Cibelli, JB, Diaz, F, Moraes, CT, Farin, PW, Farin, CE, Hammer, CJ, West, MD & Damiani, P. (2000). Cloning of an endangered species (*Bos gaurus*) using interspecies nuclear transfer. *Cloning* 2, 2, 79-90.
- Lanzendorf, SE, Zelinski-Wooten, MB, Stouffer, RL & Wolf, DP. (1990). Maturity at collection and the developmental potential of rhesus monkey oocytes. *Biology of Reproduction* 42, 4, 703-711.
- Lanzendorf SE, Holmgren WJ, Schaffer N, Hatasaka H, Wentz AC, Jeyendran RS. (1992) *In vitro* fertilization and gamete micromanipulation in the lowland gorilla. *Journal of Assisted Reproduction and Genetics* 9, 4, 358-364.
- Lattanzi, M, Santos, C, Chaves, G, Miragaya, M, Capdevielle, E, Judith, E, Agüero, A & Baranao, L. (2002). Cryopreservation of llama (*Lama glama*) embryos by slow freezing and vitrification. *Theriogenology* 57, 1, 585 (abstract).
- Lee, B, Wirtu, GG, Damiani, P, Pope, E, Dresser, BL, Hwang, W & Bavister, BD. (2003). Blastocyst development after intergeneric nuclear transfer of mountain bongo antelope somatic cells into bovine oocytes. *Cloning and Stem Cells* 5, 1, 25-33.
- Lee, DM, Yeoman, RR, Battaglia, DE, Stouffer, RL, Zelinski-Wooten, MB, Fanton, JW & Wolf, DP. (2004). Live birth after ovarian tissue transplant. *Nature* 428, 6979, 137-138.
- Lee, DR, Yang, YH, Eum, JH, Seo, JS, Ko, JJ, Chung, HM & Yoon, TK. (2007). Effect of using slush nitrogen (SN2) on development of microsurgically manipulated vitrified/warmed mouse embryos. *Human Reproduction* 22, 9, 2509-2514.
- Lee, H-J, Elmoazzen, H, Wright, D, Biggers, J, Rueda, BR, Heo, YS, Toner, M & Toth, TL. (2010). Ultra-rapid vitrification of mouse oocytes in low cryoprotectant concentrations. *Reproductive Biomedicine Online* 20, 2, 201-208.
- Leibo, SP. (1980). Water permeability and its activation energy of fertilized and unfertilized mouse ova. *Journal of Membrane Biology* 53, 3, 179-188.
- Leibo, SP & Oda, K. (1993). High survival of mouse zygotes and embryos cooled rapidly or slowly in ethylene glycol plus polyvinylpyrrolidone. *Cryo Letters* 14, 133-144.
- Lenie, S, Cortvriendt, R, Adriaenssens, T & Smitz, J. (2004). A reproducible two-step culture system for isolated primary mouse ovarian follicles as single functional units. *Biology of Reproduction* 71, 5, 1730-1738.
- Li, MW, Biggers, JD, Elmoazzen, HY, Toner, M, McGinnis, L & Lloyd, KC. (2007). Long-term storage of mouse spermatozoa after evaporative drying. *Reproduction* 133, 5, 919-929.
- Li, Z, Deng, H, Liu, C, Song, Y, Sha, J, Wang, N & Wei, H. (2002). Production of duck-chicken chimeras by transferring early blastodermal cells. *Poultry Science* 81, 9, 1360-1364.
- Li, Z, Sun, X, Chen, J, Liu, X, Wisely, SM, Zhou, Q, Renard, JP, Leno, GH & Engelhardt, JF. (2006). Cloned ferrets produced by somatic cell nuclear transfer. *Developmental Biology* 293, 2, 439-448.
- Lin, T-T, Pitt, RE & Steponkus, PL. (1989). Osmometric behavior of *Drosophila melanogaster* embryos. *Cryobiology* 26, 5, 453-471.
- Lindeberg, H, Aalto, J, Amstislavsky, S, Piltti, K, Järvinen, M & Valtonen, M. (2003). Surgical recovery and successful surgical transfer of conventionally frozen-thawed embryos in the farmed European polecat (*Mustela putorius*). *Theriogenology* 60, 8, 1515-1525.

- Liu, J, Van der Elst, J, Van den Broecke, R & Dhont, M. (2001). Live offspring by *in vitro* fertilization of oocytes from cryopreserved primordial mouse follicles after sequential *in vivo* transplantation and *in vitro* maturation. *Biology of Reproduction* 64, 1, 171-178.
- Liu, J, Van Der Elst, J, Van Den Broecke, R, Dumortier, F & Dhont, M. (2000). Maturation of mouse primordial follicles by combination of grafting and *in vitro* culture. *Biology of Reproduction* 62, 5, 1218-1223.
- Liu, J, Westhusin, M, Long, C, Johnson, G, Burghardt, R & Kraemer, D. (2010). Embryo production and possible species preservation by nuclear transfer of somatic cells isolated from bovine semen. *Theriogenology* 74, 9, 1629-1635.
- Liu, JL, Kusakabe, H, Chang, CC, Suzuki, H, Schmidt, DW, Julian, M, Pfeffer, R, Bormann, CL, Tian, XC, Yanagimachi, R & Yang, X. (2004). Freeze-dried sperm fertilization leads to full-term development in rabbits. *Biology of Reproduction* 70, 6, 1776-1781.
- Liu, L, Wood, GA, Morikawa, L, Ayearst, R, Fleming, C & McKerlie, C. (2008). Restoration of fertility by orthotopic transplantation of frozen adult mouse ovaries. *Human Reproduction* 23, 1, 122-128.
- Living Planet Report. (2008). Gland, Switzerland: World Wildlife Fund (WWF).
- Locatelli, Y, Vallet, J-C, Baril, G, Touzé, J-L, Hendricks, A, Legendre, X, Verdier, M & Mermillod, P. (2008). Successful interspecific pregnancy after transfer of *in vitro* produced sika deer (*Cervus nippon nippon*) embryo in red deer (*Cervus elaphus hippelaphus*) surrogate hind. *Reproduction, Fertility and Development* 20, 1, 160-161 (abstract).
- Loi, P, Matsukawa, K, Ptak, G, Clinton, M, Fulka Jr., J, Natan, Y & Arav, A. (2008a). Freeze-dried somatic cells direct embryonic development after nuclear transfer. *PLoS One* 3, 8, e2978.
- Loi, P, Matsukawa, K, Ptak, G, Nathan, Y, Fulka, J, Jr. & Arav, A. (2008b). Nuclear transfer of freeze dried somatic cells into enucleated sheep oocytes. *Reproduction in Domestic Animals* 43, Suppl. 2, 417-422.
- Loi, P, Modlinski, JA & Ptak, G. (2011a). Interspecies somatic cell nuclear transfer: a salvage tool seeking first aid. *Theriogenology* 76, 2, 217-228.
- Loi, P, Ptak, G, Barboni, B, Fulka, J, Jr., Cappai, P & Clinton, M. (2001). Genetic rescue of an endangered mammal by cross-species nuclear transfer using post-mortem somatic cells. *Nature Biotechnology* 19, 10, 962-964.
- Loi, P, Wakayama, T, Saragusty, J, Fulka, J, Jr. & Ptak, G. (2011b). Biological time machines: A realistic approach for cloning an extinct mammal. *Endangered Species Research* 14, 3, 227-233.
- Loomis, PR & Graham, JK. (2008). Commercial semen freezing: Individual male variation in cryosurvival and the response of stallion sperm to customized freezing protocols. *Animal Reproduction Science* 105, 1-2, 119-128.
- Loskutoff, NM, Bartels, P, Meintjes, M, Godke, RA & Schiewe, MC. (1995). Assisted reproductive technology in nondomestic ungulates: A model approach to preserving and managing genetic diversity. *Theriogenology* 43, 1, 3-12.
- Lu, F, Shi, D, Wei, J, Yang, S & Wei, Y. (2005). Development of embryos reconstructed by interspecies nuclear transfer of adult fibroblasts between buffalo (*Bubalus bubalis*) and cattle (*Bos indicus*). *Theriogenology* 64, 6, 1309-1319.

- Luvoni, GC. (2006). Gamete cryopreservation in the domestic cat. *Theriogenology* 66, 1, 101-111.
- Luvoni, GC & Pellizzari, P. (2000). Embryo development *in vitro* of cat oocytes cryopreserved at different maturation stages. *Theriogenology* 53, 8, 1529-1540.
- Luvoni, GC, Pellizzari, P & Battocchio, M. (1997). Effects of slow and ultrarapid freezing on morphology and resumption of meiosis in immature cat oocytes. *Journal of Reproduction and Fertility Supplement* 51, 93-98.
- Luyet, B. (1937). The vitrification of organic colloids and protoplasm. *Biodynamica* 1, 29, 1-14.
- Mace, G, Masundire, H, Baillie, J, Ricketts, T, Brooks, T, Hoffman, M, Stuart, S, Andrew, B, Purvis, A, Reyers, B, Wang, J, Revenga, C, Kennedy, E, Naeem, S, Alkemade, R, Allnutt, T, Bakarr, M, Bond, W, Chanson, J, Cox, N, Fonseca, G, Hilton-Taylor, C, Loucks, C, Rodrigues, A, Sechrest, W, Stattersfield, A, van Rensburg, BJ, Whiteman, C, Abell, R, Cokeliss, Z, Lamoreux, J, Pereira, HM, Thonell, J & Williams, P. (2005). Biodiversity. In: *Ecosystem and Human Well-being: Current State and Trends*, Hassan, R, Scholes, R, Ash, N, editors, p 77-122, Island Press, Washington.
- Manno III, FAM. (2010). Cryopreservation of mouse embryos by vitrification: A meta-analysis. *Theriogenology* 74, 2, 165-172.
- Martinez-Pastor, F, Garcia-Macias, V, Alvarez, M, Chamorro, C, Herraes, P, Paz, Pd & Anel, L. (2006). Comparison of two methods for obtaining spermatozoa from the cauda epididymis of Iberian red deer. *Theriogenology* 65, 3, 471-485.
- Martino, A, Songsasen, N & Leibo, SP. (1996). Development into blastocysts of bovine oocytes cryopreserved by ultra-rapid cooling. *Biology of Reproduction* 54, 5, 1059-1069.
- Martins, CF, Bao, SN, Dode, MN, Correa, GA & Rumpf, R. (2007). Effects of freeze-drying on cytology, ultrastructure, DNA fragmentation, and fertilizing ability of bovine sperm. *Theriogenology* 67, 8, 1307-1315.
- Martins, CF, Driessen, K, Melo Costa, P, Carvalho-Neto, JO, de Sousa, RV, Rumpf, R & Dode, MN. (2009). Recovery, cryopreservation and fertilization potential of bovine spermatozoa obtained from epididymides stored at 5°C by different periods of time. *Animal Reproduction Science* 116, 1-2, 50-57.
- Mastromonaco, GF & King, WA. (2007). Cloning in companion animal, non-domestic and endangered species: can the technology become a practical reality? *Reproduction, Fertility and Development* 19, 6, 748-761.
- Matoba, S & Ogura, A. (2010). Generation of functional oocytes and spermatids from fetal primordial germ cells after ectopic transplantation in adult mice. *Biology of Reproduction* 84, 4, 631-638.
- Matsumoto, H, Jiang, JY, Tanaka, T, Sasada, H & Sato, E. (2001). Vitrification of large quantities of immature bovine oocytes using nylon mesh. *Cryobiology* 42, 2, 139-144.
- Mattiske, D, Shaw, G & Shaw, JM. (2002). Influence of donor age on development of gonadal tissue from pouch young of the tamar wallaby, *Macropus eugenii*, after cryopreservation and xenografting into mice. *Reproduction* 123, 1, 143-153.
- Maxwell, WMC, Parrilla, I, Caballero, I, Garcia, E, Roca, J, Martinez, EA, Vazquez, JM & Rath, D. (2007). Retained functional integrity of bull spermatozoa after double freezing and thawing using PureSperm(R) density gradient centrifugation. *Reproduction in Domestic Animals* 42, 5, 489-494.

- Mazur, P, Leibo, SP & Seidel, GE, Jr. (2008). Cryopreservation of the germplasm of animals used in biological and medical research: importance, impact, status, and future directions. *Biology of Reproduction* 78, 1, 2-12.
- McDonnell, SM. (2001). Oral imipramine and intravenous xylazine for pharmacologically-induced ex copula ejaculation in stallions. *Animal Reproduction Science* 68, 3-4, 153-159.
- Melville, DF, Crichton, EG, Paterson-Wimberley, T & Johnston, SD. (2008). Collection of semen by manual stimulation and ejaculate characteristics of the black flying-fox (*Pteropus alecto*). *Zoo Biology* 27, 2, 159-164.
- Merino, O, Sánchez, R, Risopatrón, J, Isachenko, E, Katkov, II, Figueroa, E, Valdebenito, I, Mallmann, P & Isachenko, V. (2011). Cryoprotectant-free vitrification of fish (*Oncorhynchus mykiss*) spermatozoa: first report. *Andrologia* 124, 1-2, 125-131.
- Meryman, HT & Kafig, E. (1959). Survival of spermatozoa following drying. *Nature* 184, 4684, 470-471.
- Meyers, SA. (2006). Dry storage of sperm: applications in primates and domestic animals. *Reproduction, Fertility and Development* 18, 1-2, 1-5.
- Migishima, F, Suzuki-Migishima, R, Song, SY, Kuramochi, T, Azuma, S, Nishijima, M & Yokoyama, M. (2003). Successful cryopreservation of mouse ovaries by vitrification. *Biology of Reproduction* 68, 3, 881-887.
- Miller, DL, Waldhalm, SJ, Leopold, BD & Estill, C. (2002). Embryo transfer and embryonic capsules in the bobcat (*Lynx rufus*). *Anatomia, Histologia, Embryologia* 31, 2, 119-125.
- Miyashita, N, Kubo, Y, Yonai, M, Kaneyama, K, Saito, N, Sawai, K, Minamihashi, A, Suzuki, T, Kojima, T & Nagai, T. (2011). Cloned cows with short telomeres deliver healthy offspring with normal-length telomeres. *The Journal of Reproduction and Development* 57, 5, 636-642.
- Mocè, ML, Blasco, A & Santacreu, MA. (2010). *In vivo* development of vitrified rabbit embryos: Effects on prenatal survival and placental development. *Theriogenology* 73, 5, 704-710.
- Mochida, K, Wakayama, T, Takano, K, Noguchi, Y, Yamamoto, Y, Suzuki, O, Matsuda, J & Ogura, A. (2005). Birth of offspring after transfer of Mongolian gerbil (*Meriones unguiculatus*) embryos cryopreserved by vitrification. *Molecular Reproduction and Development* 70, 4, 464-470.
- Mochida, K, Wakayama, T, Takano, K, Noguchi, Y, Yamamoto, Y, Suzuki, O, Ogura, A & Matsuda, J. (1999). Successful cryopreservation of mongolian gerbil embryos by vitrification. *Theriogenology* 51, 1, 171 (abstract).
- Mochida, K, Yamamoto, Y, Noguchi, Y, Takano, K, Matsuda, J & Ogura, A. (2000). Survival and subsequent *in vitro* development of hamster embryos after exposure to cryoprotectant solutions. *Journal of Assisted Reproduction and Genetics* 17, 3, 182-185.
- Moghadam, KK, Nett, R, Robins, JC, Thomas, MA, Awadalla, SG, Scheiber, MD & Williams, DB. (2005). The motility of epididymal or testicular spermatozoa does not directly affect IVF/ICSI pregnancy outcomes. *Journal of Andrology* 26, 5, 619-623.
- Moisan, AE, Leibo, SP, Lynn, JW, Gómez, MC, Pope, CE, Dresser, BL & Godke, RA. (2005). Embryonic development of felid oocytes injected with freeze-dried or air-dried spermatozoa. *Cryobiology* 51, 373 (abstract).

- Montano, GA, Kraemer, DC, Love, CC, Robeck, TR & O'Brien, JK. (2010). *In vitro* function of frozen-thawed bottlenose dolphin (*Tursiops truncatus*) sperm undergoing sorting and recryopreservation. *Reproduction, Fertility and Development* 23, 1, 240 (abstract).
- Moor, RM, Dai, Y, Lee, C & Fulka, J, Jr. (1998). Oocyte maturation and embryonic failure. *Human Reproduction Update* 4, 3, 223-226.
- Moore, HD & Taggart, DA. (1995). Sperm pairing in the opossum increases the efficiency of sperm movement in a viscous environment. *Biology of Reproduction* 52, 4, 947-953.
- Morato, RG, Conforti, VA, Azevedo, FC, Jacomo, AT, Silveira, L, Sana, D, Nunes, AL, Guimaraes, MA & Barnabe, RC. (2001). Comparative analyses of semen and endocrine characteristics of free-living versus captive jaguars (*Panthera onca*). *Reproduction* 122, 5, 745-751.
- Morrow, CJ, Asher, GW, Berg, DK, Tervit, HR, Pugh, PA, McMillan, WH, Beaumont, S, Hall, DRH & Bell, ACS. (1994). Embryo transfer in fallow deer (*Dama dama*): Superovulation, embryo recovery and laparoscopic transfer of fresh and cryopreserved embryos. *Theriogenology* 42, 4, 579-590.
- Murakami, M, Otoi, T, Karja, NW, Wongsrikeao, P, Agung, B & Suzuki, T. (2004). Blastocysts derived from *in vitro*-fertilized cat oocytes after vitrification and dilution with sucrose. *Cryobiology* 48, 3, 341-348.
- Nagano, M, Avarbock, MR, Leonida, EB, Brinster, CJ & Brinster, RL. (1998). Culture of mouse spermatogonial stem cells. *Tissue and Cell* 30, 4, 389-397.
- Nagashima, H, Kashiwazaki, N, Ashman, RJ, Grupen, CG & Nottle, MB. (1995). Cryopreservation of porcine embryos. *Nature* 374, 6521, 416.
- Nagy, ZP, Chang, CC, Shapiro, DB, Bernal, DP, Kort, HI & Vajta, G. (2009). The efficacy and safety of human oocyte vitrification. *Seminars in Reproductive Medicine* 27, 6, 450-455.
- Naitana, S, Bogliolo, L, Ledda, S, Leoni, G, Madau, L, Falchi, S & Muzzeddu, M. (2000). Survival of vitrified mouflon (*Ovis g. musimon*) blastocysts. *Theriogenology* 53, 1, 340 (abstract).
- Naitana, S, Ledda, S, Loi, P, Leoni, G, Bogliolo, L, Dattena, M & Cappai, P. (1997). Polyvinyl alcohol as a defined substitute for serum in vitrification and warming solutions to cryopreserve ovine embryos at different stages of development. *Animal Reproduction Science* 48, 2-4, 247-256.
- Naito, M, Nirasawa, K & Oishi, T. (1992). Preservation of quail blastoderm cells in liquid nitrogen. *British Poultry Science* 33, 2, 449-453.
- Naito, M, Tajima, A, Tagami, T, Yasuda, Y & Kuwana, T. (1994). Preservation of chick primordial germ cells in liquid nitrogen and subsequent production of viable offspring. *Journal of Reproduction and Fertility* 102, 2, 321-325.
- Nawroth, F, Isachenko, V, Dessole, S, Rahimi, G, Farina, M, Vargiu, N, Mallmann, P, Dattena, M, Capobianco, G, Peters, D, Orth, I & Isachenko, E. (2002). Vitrification of human spermatozoa without cryoprotectants. *Cryo Letters* 23, 2, 93-102.
- Nayudu, P, Wu, J & Michelmann, H. (2003). *In vitro* development of marmoset monkey oocytes by pre-antral follicle culture. *Reproduction in Domestic Animals* 38, 2, 90-96.
- Nel-Themaat, L, Gomez, MC, Pope, CE, Lopez, M, Wirtu, G, Cole, A, Dresser, BL, Lyons, LA, Bondioli, KR & Godke, RA. (2008a). Cloned embryos from semen. Part 1: *In vitro* proliferation of epithelial cells on embryonic fibroblasts after isolation from semen by gradient centrifugation. *Cloning and Stem Cells* 10, 1, 143-160.

- Nel-Themaat, L, Gomez, MC, Pope, CE, Lopez, M, Wirtu, G, Jenkins, JA, Cole, A, Dresser, BL, Bondioli, KR & Godke, RA. (2008b). Cloned embryos from semen. Part 2: Intergeneric nuclear transfer of semen-derived eland (*Taurotragus oryx*) epithelial cells into bovine oocytes. *Cloning and Stem Cells* 10, 1, 161-172.
- Niikura, Y, Niikura, T & Tilly, JL. (2009). Aged mouse ovaries possess rare premeiotic germ cells that can generate oocytes following transplantation into a young host environment. *Aging* 1, 12, 971-978.
- Nowshari, MA, Ali, SA & Saleem, S. (2005). Offspring resulting from transfer of cryopreserved embryos in camel (*Camelus dromedarius*). *Theriogenology* 63, 9, 2513-2522.
- Noyes, N, Boldt, J & Nagy, ZP. (2010). Oocyte cryopreservation: is it time to remove its experimental label? *Journal of Assisted Reproduction and Genetics* 27, 2-3, 69-74.
- O'Brien, JK, Hollinshead, FK, Evans, KM, Evans, G & Maxwell, WM. (2004). Flow cytometric sorting of frozen-thawed spermatozoa in sheep and non-human primates. *Reproduction, Fertility and Development* 15, 7, 367-375.
- O'Brien, JK & Robeck, TR. (2006). Development of sperm sexing and associated assisted reproductive technology for sex preselection of captive bottlenose dolphins (*Tursiops truncatus*). *Reproduction, Fertility and Development* 18, 3, 319-329.
- O'Brien, JK & Robeck, TR. (2010). The value of *ex situ* Cetacean populations in understanding reproductive physiology and developing assisted reproductive technology for *ex situ* species management and conservation efforts. *International Journal of Comparative Psychology* 23, 3, 227-248.
- O'Brien, JK & Roth, TL. (2000). Post-coital sperm recovery and cryopreservation in the Sumatran rhinoceros (*Dicerorhinus sumatrensis*) and application to gamete rescue in the African black rhinoceros (*Diceros bicornis*). *Journal of Reproduction and Fertility* 118, 2, 263-271.
- Ogonuki, N, Mochida, K, Miki, H, Inoue, K, Fray, M, Iwaki, T, Moriwaki, K, Obata, Y, Morozumi, K, Yanagimachi, R & Ogura, A. (2006). Spermatozoa and spermatids retrieved from frozen reproductive organs or frozen whole bodies of male mice can produce normal offspring. *Proceedings of the National Academy of Sciences of the United States of America* 103, 35, 13098-13103.
- Oh, HJ, Kim, MK, Jang, G, Kim, HJ, Hong, SG, Park, JE, Park, K, Park, C, Sohn, SH, Kim, DY, Shin, NS & Lee, BC. (2008). Cloning endangered gray wolves (*Canis lupus*) from somatic cells collected postmortem. *Theriogenology* 70, 4, 638-647.
- Okita, K, Ichisaka, T & Yamanaka, S. (2007). Generation of germline-competent induced pluripotent stem cells. *Nature* 448, 7151, 313-317.
- Oliveira, KG, Miranda, SA, Leão, DL, Brito, AB, Santos, RR & Domingues, SFS. (2010). Semen coagulum liquefaction; sperm activation and cryopreservation of capuchin monkey (*Cebus apella*) semen in coconut water solution (CWS) and TES-TRIS. *Animal Reproduction Science* 123, 1-2, 75-80.
- Onions, VJ, Webb, R, McNeilly, AS & Campbell, BK. (2009). Ovarian endocrine profile and long-term vascular patency following heterotopic autotransplantation of cryopreserved whole ovine ovaries. *Human Reproduction* 24, 11, 2845-2855.
- Ono, T, Mizutani, E, Li, C & Wakayama, T. (2008). Nuclear transfer preserves the nuclear genome of freeze-dried mouse cells. *Journal of Reproduction and Development* 54, 6, 486-491.

- Pan, G, Chen, Z, Liu, X, Li, D, Xie, Q, Ling, F & Fang, L. (2001). Isolation and purification of the ovulation-inducing factor from seminal plasma in the bactrian camel (*Camelus bactrianus*). *Theriogenology* 55, 9, 1863-1879.
- Papis, K, Korwin-Kossakowski, M & Wenta-Muchalska, E. (2009). Comparison of traditional and modified (VitMaster) methods of rabbit embryo vitrification. *Acta Veterinaria Hungarica* 57, 3, 411-416.
- Paris, M, Millar, R, Colenbrander, B & Schwarzenberger, F. (2008). Non-invasive assessment of female reproductive physiology in the pygmy hippopotamus (*Choeropsis liberiensis*). *Reproduction in Domestic Animals* 43, s3, 21 (abstract).
- Paris, MCJ, Snow, M, Cox, S-L & Shaw, JM. (2004). Xenotransplantation: a tool for reproductive biology and animal conservation? *Theriogenology* 61, 2-3, 277-291.
- Parkening, TA, Tsunoda, Y & Chang, MC. (1976). Effects of various low temperatures, cryoprotective agents and cooling rates on the survival, fertilizability and development of frozen-thawed mouse eggs. *Journal of Experimental Zoology* 197, 3, 369-374.
- Parrott, DMV. (1960). The fertility of mice with orthotopic ovarian grafts derived from frozen tissue. *Journal of Reproduction and Fertility* 1, 3, 230-241.
- Patakine Varkonyi, E, Vegi, B, Varadi, E, Liptoi, K & Barna, J. (2007). Preliminary results of cryopreservation of early embryonic cells of goose. 5th Vietnamese-Hungarian International Conference on „Animal Production and Aquaculture for Sustainable Farming”. Can Tho, Vietnam: Can Tho University. p 82-85.
- Pickering, SJ & Johnson, MH. (1987). The influence of cooling on the organization of meiotic spindle of the mouse oocyte. *Human Reproduction* 2, 3, 207-216.
- Piltti, K, Lindeberg, H, Aalto, J & Korhonen, H. (2004). Live cubs born after transfer of OPS vitrified-warmed embryos in the farmed European polecat (*Mustela putorius*). *Theriogenology* 61, 5, 811-820.
- Pimm, SL, Russell, GJ, Gittleman, JL & Brooks, TM. (1995). The future of biodiversity. *Science* 269, 5222, 347-350.
- Polejaeva, IA, Chen, SH, Vaught, TD, Page, RL, Mullins, J, Ball, S, Dai, Y, Boone, J, Walker, S, Ayares, DL, Colman, A & Campbell, KH. (2000). Cloned pigs produced by nuclear transfer from adult somatic cells. *Nature* 407, 6800, 86-90.
- Poleo, GA, Godke, RR & Tiersch, TR. (2005). Intracytoplasmic sperm injection using cryopreserved, fixed, and freeze-dried sperm in eggs of Nile tilapia. *Marine Biotechnology (New York, NY)* 7, 2, 104-111.
- Polge, C, Smith, AU & Parkes, AS. (1949). Revival of spermatozoa after vitrification and dehydration at low temperatures. *Nature* 164, 4172, 666.
- Pope, CE. (2000). Embryo technology in conservation efforts for endangered felids. *Theriogenology* 53, 1, 163-174.
- Pope, CE, Dresser, BL, Chin, NW, Liu, JH, Loskutoff, NM, Behnke, EJ, Brown, C, McRae, MA, Sinoway, CE, Campbell, MK, Cameron, KN, Owens, ODM, Johnson, CA, Evans, RR & Cedars, MI. (1997a). Birth of a Western Lowland gorilla (*Gorilla gorilla gorilla*) following *in vitro* fertilization and embryo transfer. *American Journal of Primatology* 41, 3, 247-260.
- Pope, CE, Gómez, MC, Cole, A, Dumas, C & Dresser, BL. (2005). Oocyte recovery, *in vitro* fertilization and embryo transfer in the serval (*Leptailurus serval*). *Reproduction, Fertility and Development* 18, 2, 223 (abstract).



- Pope, CE, Gomez, MC & Dresser, BL. (2006). *In vitro* embryo production and embryo transfer in domestic and non-domestic cats. *Theriogenology* 66, 6-7, 1518-1524.
- Pope, CE, Gomez, MC & Dresser, BL. (2009). *In vitro* embryo production in the clouded leopard (*Neofelis nebulosa*). *Reproduction, Fertility and Development* 22, 1, 258 (abstract).
- Pope, CE, Gomez, MC, Harris, RF & Dresser, BL. (2002). Development of *in vitro* matured, *in vitro* fertilized cat embryos following cryopreservation, culture and transfer. *Theriogenology* 57, 1, 464 (abstract).
- Pope, CE, Gómez, MC, Mikota, SK & Dresser, BL. (2000). Development of *in vitro* produced African wild cat (*Felis silvestris*) embryos after cryopreservation and transfer into domestic cat recipients. *Biology of Reproduction* 62 (Suppl 1), 321 (abstract).
- Pope, CE, McRae, MA, Plair, BL, Keller, GL & Dresser, BL. (1994). Successful *in vitro* and *in vivo* development of *in vitro* fertilized two- to four-cell cat embryos following cryopreservation, culture and transfer. *Theriogenology* 42, 3, 513-525.
- Pope, CE, McRae, MA, Plair, BL, Keller, GL & Dresser, BL. (1997b). *In vitro* and *in vivo* development of embryos produced by *in vitro* maturation and *in vitro* fertilization of cat oocytes. *Journal of Reproduction and Fertility Supplement* 51, 69-82.
- Pope, CE, Pope, VZ & Beck, LR. (1984). Live birth following cryopreservation and transfer of a baboon embryo. *Fertility and Sterility* 42, 1, 143-145.
- Popelkova, M, Turanova, Z, Koprdoва, L, Ostro, A, Toporcerova, S, Makarevich, AV & Chrenek, P. (2009). Effect of vitrification technique and assisted hatching on rabbit embryo developmental rate. *Zygote* 17, 1, 57-61.
- Pribenszky, C, Molnar, M, Horvath, A, Harnos, A & Szenci, O. (2006). Hydrostatic pressure induced increase in post-thaw motility of frozen boar spermatozoa. *Reproduction, Fertility and Development* 18, 2, 162-163 (abstract).
- Pribenszky, C & Vajta, G. (2010). Cells under pressure: how sublethal hydrostatic pressure stress treatment increases gametes' and embryos' performance? *Reproduction, Fertility and Development* 23, 1, 48-55.
- Ptak, G, Clinton, M, Barboni, B, Muzzeddu, M, Cappai, P, Tischner, M & Loi, P. (2002). Preservation of the wild European mouflon: the first example of genetic management using a complete program of reproductive biotechnologies. *Biology of Reproduction* 66, 3, 796-801.
- Qi, S, Ma, A, Xu, D, Daloz, P & Chen, H. (2008). Cryopreservation of vascularized ovary: an evaluation of histology and function in rats. *Microsurgery* 28, 5, 380-386.
- Quinn, PJ & White, IG. (1967). Phospholipid and cholesterol content of epididymal and ejaculated ram spermatozoa and seminal plasma in relation to cold shock. *Australian Journal of Biological Science* 20, 1205-1215.
- Quintans, CJ, Donaldson, MJ, Bertolino, MV & Pasqualini, RS. (2002). Birth of two babies using oocytes that were cryopreserved in a choline-based freezing medium. *Human Reproduction* 17, 12, 3149-3152.
- Rabon, DRJ & Waddell, W. (2010). Effects of inbreeding on reproductive success, performance, litter size, and survival in captive red wolves (*Canis rufus*). *Zoo Biology* 29, 1, 36-49.
- Rall, WF. (2001). Cryopreservation of mammalian embryos, gametes, and ovarian tissue. In: *Assisted Fertilization and Nuclear Transfer in Mammals*, Wolf, DP, Zelinski-Wooten, MB, editors, p 173-187, Humana Press Inc., Totowa, NJ.

- Rao, BS, Mahesh, YU, Suman, K, Charan, KV, Lakshmikantan, U, Gibence, HRW & Shivaji, S. (2011). Meiotic maturation of vitrified immature chousingha (*Tetracerus quadricornis*) oocytes recovered postmortem. *Cryobiology* 62, 1, 47-52.
- Rawson, DM, Zhang, T, Kalicharan, D & Jongebloed, WL. (2000). Field emission scanning electron microscopy and transmission electron microscopy studies of the chorion, plasma membrane and syncytial layers of the gastrula-stage embryo of the zebrafish *Brachydanio rerio*: a consideration of the structural and functional relationships with respect to cryoprotectant penetration. *Aquaculture Research* 31, 3, 325-336.
- Reid, CE, Hermes, R, Blottner, S, Goeritz, F, Wibbelt, G, Walzer, C, Bryant, BR, Portas, TJ, Streich, WJ & Hildebrandt, TB. (2009). Split-sample comparison of directional and liquid nitrogen vapour freezing method on post-thaw semen quality in white rhinoceroses (*Ceratotherium simum simum* and *Ceratotherium simum cottoni*). *Theriogenology* 71, 2, 275-291.
- Reid, WV & Miller, KR. (1989). Keeping Options Alive: The scientific basis for the conservation of biodiversity. Washington, DC: World Resources Institute.
- Reubinoff, BE, Pera, MF, Vajta, G & Trounson, AO. (2001). Effective cryopreservation of human embryonic stem cells by the open pulled straw vitrification method. *Human Reproduction* 16, 10, 2187-2194.
- Revel, A, A, E, Bor, A, Yavin, S, Natan, Y & Arav, A. (2001). Intact sheep ovary cryopreservation and transplantation. *Fertility and Sterility* 76, 3, Suppl. 1, S42-S43 (abstract).
- Revel, A, Elami, A, Bor, A, Yavin, S, Natan, Y & Arav, A. (2004). Whole sheep ovary cryopreservation and transplantation. *Fertility and Sterility* 82, 6, 1714-1715.
- Reynaud, K, Fontbonne, A, Marseloo, N, Thoumire, S, Chebrou, M, de Lesegno, CV & Chastant-Maillard, S. (2005). *In vivo* meiotic resumption, fertilization and early embryonic development in the bitch. *Reproduction* 130, 2, 193-201.
- Ridha, MT & Dukelow, WR. (1985). The developmental potential of frozen-thawed hamster preimplantation embryos following embryo transfer: Viability of slowly frozen embryos following slow and rapid thawing. *Animal Reproduction Science* 9, 3, 253-259.
- Riel, JM, Huang, TT & Ward, MA. (2007). Freezing-free preservation of human spermatozoa--a pilot study. *Archives of Andrology* 53, 5, 275-284.
- Riel, JM, Yamauchi, Y, Huang, TTF, Grove, J & Ward, MA. (2011). Short-term storage of human spermatozoa in electrolyte-free medium without freezing maintains sperm chromatin integrity better than cryopreservation. *Biology of Reproduction* 85, 3, 536-547.
- Ringleb, J, Waurich, R, Wibbelt, G, Streich, WJ & Jewgenow, K. (2011). Prolonged storage of epididymal spermatozoa does not affect their capacity to fertilise *in vitro*-matured domestic cat (*Felis catus*) oocytes when using ICSI. *Reproduction, Fertility and Development* 23, 6, 818-825.
- Risco, R, Elmoazzen, H, Doughty, M, He, X & Toner, M. (2007). Thermal performance of quartz capillaries for vitrification. *Cryobiology* 55, 3, 222-229.
- Rizos, D, Ward, F, Duffy, P, Boland, MP & Lonergan, P. (2002). Consequences of bovine oocyte maturation, fertilization or early embryo development *in vitro* versus *in vivo*:

- Implications for blastocyst yield and blastocyst quality. *Molecular Reproduction and Development* 61, 2, 234-248.
- Robeck, TR, Gearhart, SA, Steinman, KJ, Katsumata, E, Loureiro, JD & O'Brien, JK. (2011). *In vitro* sperm characterization and development of a sperm cryopreservation method using directional solidification in the killer whale (*Orcinus orca*). *Theriogenology* 76, 2, 267-279.
- Robeck, TR & O'Brien, JK. (2004). Effect of cryopreservation methods and precryopreservation storage on bottlenose dolphin (*Tursiops truncatus*) Spermatozoa. *Biology of Reproduction* 70, 5, 1340-1348.
- Robles, V, Cabrita, E & Herraéz, MP. (2009). Germplasm cryobanking in zebrafish and other aquarium model species. *Zebrafish* 6, 3, 281-293.
- Robles, V, Cabrita, E, Real, M, Álvarez, R & Herráez, MP. (2003). Vitrification of turbot embryos: preliminary assays. *Cryobiology* 47, 1, 30-39.
- Rockstrom, J, Steffen, W, Noone, K, Persson, A, Chapin, FSr, Lambin, EF, Lenton, TM, Scheffer, M, Folke, C, Schellnhuber, HJ, Nykvist, B, de Wit, CA, Hughes, T, van der Leeuw, S, Rodhe, H, Sorlin, S, Snyder, PK, Costanza, R, Svedin, U, Falkenmark, M, Karlberg, L, Corell, RW, Fabry, VJ, Hansen, J, Walker, B, Liverman, D, Richardson, K, Crutzen, P & Foley, JA. (2009). A safe operating space for humanity. *Nature* 461, 7263, 472-475.
- Rodger, JC, Giles, I & Mate, KE. (1992). Unexpected oocyte growth after follicular antrum formation in four marsupial species. *Journal of Reproduction and Fertility* 96, 2, 755-763.
- Rodrigues, BA & Rodrigues, JL. (2006). Responses of canine oocytes to *in vitro* maturation and *in vitro* fertilization outcome. *Theriogenology* 66, 6-7, 1667-1672.
- Rodriguez-Sosa, JR, Foster, RA & Hahnel, A. (2010). Development of strips of ovine testes after xenografting under the skin of mice and co-transplantation of exogenous spermatogonia with grafts. *Reproduction* 139, 1, 227-235.
- Roldan, ERS, Cassinello, J, Abaigar, T & Gomendio, M. (1998). Inbreeding, fluctuating asymmetry, and ejaculate quality in an endangered ungulate. *Proceedings of the Royal Society of London. Series B: Biological Sciences* 265, 1392, 243-248.
- Roth, TL, Bush, LM, Wildt, DE & Weiss, RB. (1999). Scimitar-horned oryx (*Oryx dammah*) spermatozoa are functionally competent in a heterologous bovine *in vitro* fertilization system after cryopreservation on dry ice, in a dry shipper, or over liquid nitrogen vapor. *Biology of Reproduction* 60, 2, 493-8.
- Roth, TL, Stoops, MA, Atkinson, MW, Blumer, ES, Campbell, MK, Cameron, KN, Citino, SB & Maas, AK. (2005). Semen collection in rhinoceroses (*Rhinoceros unicornis*, *Diceros bicornis*, *Ceratotherium simum*) by electroejaculation with a uniquely designed probe. *Journal of Zoo and Wildlife Medicine* 36, 4, 617-627.
- Roth, TL, Stoops, MA, Robeck, TR, Ball, RL, Wolf, BA, Finnegan, MV & O'Brien, JK. (2010). Alkaline phosphatase as an indicator of true ejaculation in the rhinoceros. *Theriogenology* 74, 9, 1701-1706.
- Roth, TL, Swanson, WF, Collins, D, Burton, M, Garell, DM & Wildt, DE. (1996). Snow leopard (*Panthera uncia*) spermatozoa are sensitive to alkaline pH, but motility *in vitro* is not influenced by protein or energy supplements. *Journal of Andrology* 17, 5, 558-566.

- Roussel, JD, Kellgren, HC & Patrick, TE. (1964). Bovine semen frozen in liquid nitrogen vapor. *Journal of Dairy Science* 47, 12, 1403-1406.
- Roy, VK & Krishna, A. (2011). Sperm storage in the female reproductive tract of *Scotophilus heathii*: Role of androgen. *Molecular Reproduction and Development* 78, 7, 477-487.
- Ruffing, NA, Steponkus, PL, Pitt, RE & Parks, JE. (1993). Osmometric behavior, hydraulic conductivity, and incidence of intracellular ice formation in bovine oocytes at different developmental stages. *Cryobiology* 30, 6, 562-580.
- Ruiz-Lopez, MJ, Evenson, DP, Espeso, G, Gomendio, M & Roldan, ER. (2010). High levels of DNA fragmentation in spermatozoa are associated with inbreeding and poor sperm quality in endangered ungulates. *Biology of Reproduction* 83, 3, 332-338.
- Ruttimann, J. (2006). Doomsday food store takes pole position. *Nature* 441, 7096, 912-913.
- Salehnia, M, Moghadam, EA & Velojerdi, MR. (2002). Ultrastructure of follicles after vitrification of mouse ovarian tissue. *Fertility and Sterility* 78, 3, 644-645.
- Sanchez, R, Isachenko, V, Petrunkina, AM, Risopatron, J, Schulz, M & Isachenko, E. (2011). Live birth after intrauterine insemination with spermatozoa from an oligo-asthenozoospermic patient vitrified without permeable cryoprotectants. *Journal of Andrology*. In Press.
- Sanchez-Partida, LG, Simerly, CR & Ramalho-Santos, J. (2008). Freeze-dried primate sperm retains early reproductive potential after intracytoplasmic sperm injection. *Fertility and Sterility* 89, 3, 742-745.
- Santiago-Moreno, J, Toledano-Díaz, A, Sookhthezary, A, Gómez-Guillamón, F, de la Vega, RS, Pulido-Pastor, A & López-Sebastián, A. (2010). Effects of anesthetic protocols on electroejaculation variables of Iberian ibex (*Capra pyrenaica*). *Research in Veterinary Science* 90, 1, 150-155.
- Santos, R, Tharasanit, T, Van Haefen, T, Figueiredo, J, Silva, J & Van den Hurk, R. (2007). Vitrification of goat preantral follicles enclosed in ovarian tissue by using conventional and solid-surface vitrification methods. *Cell and Tissue Research* 327, 1, 167-176.
- Santos, RMD, Barreta, MH, Frajblat, M, Cucco, DC, Mezzalira, JC, Bunn, S, Cruz, FB, Vieira, AD & Mezzalira, A. (2006). Vacuum-cooled liquid nitrogen increases the developmental ability of vitrified-warmed bovine oocytes. *Ciencia Rural* 36, 5, 1501-1506.
- Saragusty, J & Arav, A. (2011). Current progress in oocyte and embryo cryopreservation by slow freezing and vitrification. *Reproduction* 141, 1, 1-19.
- Saragusty, J, Gacitua, H, King, R & Arav, A. (2006). Post-mortem semen cryopreservation and characterization in two different endangered gazelle species (*Gazella gazella* and *Gazella dorcas*) and one subspecies (*Gazella gazelle acaiae*). *Theriogenology* 66, 4, 775-784.
- Saragusty, J, Gacitua, H, Pettit, MT & Arav, A. (2007). Directional freezing of equine semen in large volumes. *Reproduction in Domestic Animals* 42, 6, 610-615.
- Saragusty, J, Gacitua, H, Rozenboim, I & Arav, A. (2009a). Do physical forces contribute to cryodamage? *Biotechnology and Bioengineering* 104, 4, 719-728.
- Saragusty, J, Gacitua, H, Rozenboim, I & Arav, A. (2009b). Protective effects of iodixanol during bovine sperm cryopreservation. *Theriogenology* 71, 9, 1425-1432.
- Saragusty, J, Gacitua, H, Zeron, Y, Rozenboim, I & Arav, A. (2009c). Double freezing of bovine semen. *Animal Reproduction Science* 115, 1-4, 10-17.

- Saragusty, J, Hermes, R, Göritz, F, Schmitt, DL & Hildebrandt, TB. (2009d). Skewed birth sex ratio and premature mortality in elephants. *Animal Reproduction Science* 115, 1-4, 247-254.
- Saragusty, J, Hildebrandt, TB, Behr, B, Knieriem, A, Kruse, J & Hermes, R. (2009e). Successful cryopreservation of Asian elephant (*Elephas maximus*) spermatozoa. *Animal Reproduction Science* 115, 1-4, 255-266.
- Saragusty, J, Hildebrandt, TB, Bouts, T, Göritz, F & Hermes, R. (2010a). Collection and preservation of pygmy hippopotamus (*Choeropsis liberiensis*) semen. *Theriogenology* 74, 4, 652-657.
- Saragusty, J, Hildebrandt, TB, Natan, Y, Hermes, R, Yavin, S, Göritz, F & Arav, A. (2005). Effect of egg-phosphatidylcholine on the chilling sensitivity and lipid phase transition of Asian elephant (*Elephas maximus*) spermatozoa. *Zoo Biology* 24, 3, 233-245.
- Saragusty, J, Walzer, C, Petit, T, Stalder, G, Horowitz, I & Hermes, R. (2010b). Cooling and freezing of epididymal sperm in the common hippopotamus (*Hippopotamus amphibius*). *Theriogenology* 74, 7, 1256-1263.
- Saroff, J & Mixner, JP. (1955). The relationship of egg yolk and glycerol content of diluters and glycerol equilibration time to survival of bull spermatozoa after low temperature freezing. *Journal of Dairy Science* 38, 3, 292-297.
- Sathananthan, AH, Ng, SC, Trounson, AO, Bongso, A, Ratnam, SS, Ho, J, Mok, H & Lee, MN. (1988). The effects of ultrarapid freezing on meiotic and mitotic spindles of mouse oocytes and embryos. *Gamete Research* 21, 4, 385-401.
- Sato, T, Katagiri, K, Gohbara, A, Inoue, K, Ogonuki, N, Ogura, A, Kubota, Y & Ogawa, T. (2011). *In vitro* production of functional sperm in cultured neonatal mouse testes. *Nature* 471, 7339, 504-507.
- Schiewe, MC. (1991). The science and significance of embryo cryopreservation. *Journal of Zoo and Wildlife Medicine* 22, 1, 6-22.
- Schiewe, MC, Bush, M, Phillips, LG, Citino, S & Wildt, DE. (1991a). Comparative aspects of estrus synchronization, ovulation induction, and embryo cryopreservation in the scimitar-horned oryx, bongo, eland, and greater kudu. *Journal of Experimental Zoology* 258, 1, 75-88.
- Schlatt, S, Foppiani, L, Rolf, C, Weinbauer, GF & Nieschlag, E. (2002a). Germ cell transplantation into X-irradiated monkey testes. *Human Reproduction* 17, 1, 55-62.
- Schlatt, S, Kim, SS & Gosden, R. (2002b). Spermatogenesis and steroidogenesis in mouse, hamster and monkey testicular tissue after cryopreservation and heterotopic grafting to castrated hosts. *Reproduction* 124, 3, 339-346.
- Schmitt, DL & Hildebrandt, TB. (1998). Manual collection and characterization of semen from Asian elephants (*Elephas maximus*). *Animal Reproduction Science* 53, 1-4, 309-314.
- Schmitt, DL & Hildebrandt, TB. (2000). Corrigendum to "Manual collection and characterization of semen from asian elephants" [Anim. Reprod. Sci. 53 (1998) 309-314]. *Animal Reproduction Science* 59, 1-2, 119.
- Schneider, W. (1992). Lipoprotein receptors in oocyte growth. *Journal of Molecular Medicine* 70, 5, 385-390.

- Schneiders, A, Sonksen, J & Hodges, JK. (2004). Penile vibratory stimulation in the marmoset monkey: a practical alternative to electro-ejaculation, yielding ejaculates of enhanced quality. *Journal of Medical Primatology* 33, 2, 98-104.
- Schnorr, J, Oehninger, S, Toner, J, Hsiu, J, Lanzendorf, S, Williams, R & Hodgen, G. (2002). Functional studies of subcutaneous ovarian transplants in non-human primates: steroidogenesis, endometrial development, ovulation, menstrual patterns and gamete morphology. *Human Reproduction* 17, 3, 612-619.
- Schoysman, R, Vanderzwalmen, P, Nijs, M, Segal, L, Segal-Bertin, G, Geerts, L, van Roosendaal, E & Schoysman, D. (1993). Pregnancy after fertilisation with human testicular spermatozoa. *The Lancet* 342, 8881, 1237.
- Selman, K, Wallace, RA, Sarka, A & Qi, X. (1993). Stages of oocyte development in the zebrafish, *Brachydanio rerio*. *Journal of Morphology* 218, 2, 203-224.
- Shaw, J, Temple-Smith, P, Trounson, A & Lamden, K. (1996). Fresh and frozen marsupial (*Sminthopsis crassicaudata*) ovaries develop after grafting to SCID mice. *Cryobiology* 33, 6, 631 (abstract).
- Sherman, JK. (1954). Freezing and freeze-drying of human spermatozoa. *Fertility and Sterility* 5, 4, 357-371.
- Sherman, JK. (1957). Freezing and freeze-drying of bull spermatozoa. *American Journal of Physiology* 190, 2, 281-286.
- Sherman, JK. (1963). Improved methods of preservation of human spermatozoa by freezing and freeze-drying. *Fertility and Sterility* 14, 49-64.
- Shi, D, Lu, F, Wei, Y, Cui, K, Yang, S, Wei, J & Liu, Q. (2007). Buffalos (*Bubalus bubalis*) cloned by nuclear transfer of somatic cells. *Biology of Reproduction* 77, 2, 285-291.
- Shiels, PG, Kind, AJ, Campbell, KHS, Wilmut, I, Waddington, D, Colman, A & Schnieke, AE. (1999). Analysis of telomere length in Dolly, a sheep derived by nuclear transfer. *Cloning* 1, 2, 119-125.
- Shin, T, Kraemer, D, Pryor, J, Liu, L, Rugila, J, Howe, L, Buck, S, Murphy, K, Lyons, L & Westhusin, M. (2002). A cat cloned by nuclear transplantation. *Nature* 415, 6874, 859.
- Shinohara, T, Inoue, K, Ogonuki, N, Kanatsu-Shinohara, M, Miki, H, Nakata, K, Kurome, M, Nagashima, H, Toyokuni, S, Kogishi, K, Honjo, T & Ogura, A. (2002). Birth of offspring following transplantation of cryopreserved immature testicular pieces and *in-vitro* microinsemination. *Human Reproduction* 17, 12, 3039-3045.
- Shinohara, T, Kato, M, Takehashi, M, Lee, J, Chuma, S, Nakatsuji, N, Kanatsu-Shinohara, M & Hirabayashi, M. (2006). Rats produced by interspecies spermatogonial transplantation in mice and *in vitro* microinsemination. *Proceedings of the National Academy of Sciences of the United States of America* 103, 37, 13624-13628.
- Si, W, Hildebrandt, TB, Reid, C, Krieg, R, Ji, W, Fassbender, M & Hermes, R. (2006). The successful double cryopreservation of rabbit (*Oryctolagus cuniculus*) semen in large volume using the directional freezing technique with reduced concentration of cryoprotectant. *Theriogenology* 65, 4, 788-798.
- Silva, RC, Costa, GMJ, Lacerda, SMSN, Batlouni, SR, Soares, JM, Avelar, GF, Bottger, KB, Silva, SF, Jr., Noqueira, MS, Andrade, LM & Franca, LR. (2011). Germ cell transplantation in Felids: A potential approach to preserving endangered species. *Journal of Andrology* 76, 6, 1084-1089.

- Skidmore, JA & Loskutoff, NM. (1999). Developmental competence *in vitro* and *in vivo* of cryopreserved expanding blastocysts from the dromedary camel (*Camelus dromedarius*). *Theriogenology* 51, 1, 293 (abstract).
- Slade, NP, Takeda, T, Squires, EL, Elsdon, RP & Seidel, GE, Jr. (1985). A new procedure for the cryopreservation of equine embryos. *Theriogenology* 24, 1, 45-58.
- Smith, AU & Parkes, AS. (1951). Preservation of ovarian tissue at low temperatures. *The Lancet* 258, 6683, 570-572.
- Snedaker, AK, Honaramooz, A & Dobrinski, I. (2004). A game of cat and mouse: Xenografting of testis tissue from domestic kittens results in complete cat spermatogenesis in a mouse host. *Journal of Andrology* 25, 6, 926-930.
- Snow, M, Cox, SL, Jenkin, G, Trounson, A & Shaw, J. (2002). Generation of live young from xenografted mouse ovaries. *Science* 297, 5590, 2227.
- Soler, JP, Mucci, N, Kaiser, GG, Aller, J, Hunter, JW, Dixon, TE & Alberio, RH. (2007). Multiple ovulation and embryo transfer with fresh, frozen and vitrified red deer (*Cervus elaphus*) embryos in Argentina. *Animal Reproduction Science* 102, 3-4, 322-327.
- Spindler, RE, Pukazhenthi, BS & Wildt, DE. (2000). Oocyte metabolism predicts the development of cat embryos to blastocyst *in vitro*. *Molecular Reproduction and Development* 56, 2, 163-171.
- Srirattana, K, Matsukawa, K, Akagi, S, Tasai, M, Tagami, T, Nirasawa, K, Nagai, T, Kanai, Y, Parnpai, R & Takeda, K. (2011). Constant transmission of mitochondrial DNA in intergeneric cloned embryos reconstructed from swamp buffalo fibroblasts and bovine ooplasm. *Animal Science Journal* 82, 2, 236-243.
- Stachecki, JJ, Cohen, J & Willadsen, S. (1998a). Detrimental effects of sodium during mouse oocyte cryopreservation. *Biology of Reproduction* 59, 2, 395-400.
- Stachecki, JJ, Cohen, J & Willadsen, SM. (1998b). Cryopreservation of unfertilized mouse oocytes: the effect of replacing sodium with choline in the freezing medium. *Cryobiology* 37, 4, 346-354.
- Steponkus, PL, Myers, SP, Lynch, DV, Gardner, L, Bronshteyn, V, Leibo, SP, Rall, WF, Pitt, RE, Lin, TT & MacIntyre, RJ. (1990). Cryopreservation of *Drosophila melanogaster* embryos. *Nature* 345, 6271, 170-172.
- Stover, J & Evans, J. (1984) Interspecies embryos transfer from gaur (*Bos gaurus*) to domestic Holstein cattle (*Bos taurus*) at the New York Zoological Park. *Proceedings of the 10th International Congress on Animal Reproduction and Artificial Insemination*, University of Illinois at Urbana-Champaign, Illinois, USA, June 10-14, 1984.
- Stukenborg, J-B, Schlatt, S, Simoni, M, Yeung, C-H, Elhija, MA, Luetjens, CM, Huleihel, M & Wistuba, J. (2009). New horizons for *in vitro* spermatogenesis? An update on novel three-dimensional culture systems as tools for meiotic and post-meiotic differentiation of testicular germ cells. *Molecular Human Reproduction* 15, 9, 521-529.
- Sugimoto, M, Maeda, S, Manabe, N & Miyamoto, H. (2000). Development of infantile rat ovaries autotransplanted after cryopreservation by vitrification. *Theriogenology* 53, 5, 1093-1103.
- Summers, PM, Shephard, AM, Taylor, CT & Hearn, JP. (1987). The effects of cryopreservation and transfer on embryonic development in the common marmoset monkey, *Callithrix jacchus*. *Journal of Reproduction and Fertility* 79, 1, 241-250.

- Sun, X, Li, Z, Yi, Y, Chen, J, Leno, GH & Engelhardt, JF. (2008). Efficient term development of vitrified ferret embryos using a novel pipette chamber technique. *Biology of Reproduction* 79, 5, 832-840.
- Suzuki, H, Asano, T, Suwa, Y & Abe, Y. (2009). Successful delivery of pups from cryopreserved canine embryos. *Biology of Reproduction* 81, 1 supplement, 619 (abstract).
- Swanson, WF. (2001) Reproductive biotechnology and conservation of the forgotten felids - the small cats. *The 1st International Symposium on Assisted Reproductive Technology for the Conservation and Genetic Management of Wildlife*, Omaha, 17-18 Januar, 2001.
- Swanson, WF. (2003). Research in nondomestic species: Experiences in reproductive physiology research for conservation of endangered felids. *ILAR Journal* 44, 4, 307-316.
- Swanson, WF. (2006). Application of assisted reproduction for population management in felids: The potential and reality for conservation of small cats. *Theriogenology* 66, 1, 49-58.
- Swanson, WF & Brown, JL. (2004). International training programs in reproductive sciences for conservation of Latin American felids. *Animal Reproduction Science* 82-83, 21-34.
- Swanson, WF, Paz, RCR, Morais, RN, Gomes, MLF, Moraes, W & Adania, CH. (2002). Influence of species and diet on efficiency of *in vitro* fertilization in two endangered Brazilian felids - the ocelot (*Leopardus pardalis*) and tigrina (*Leopardus tigrinus*). *Theriogenology* 57, 1, 593 (abstract).
- Takagi, M, Kim, IH, Izadyar, F, Hyttel, P, Bevers, MM, Dieleman, SJ, Hendriksen, PJ & Vos, PL. (2001). Impaired final follicular maturation in heifers after superovulation with recombinant human FSH. *Reproduction* 121, 6, 941-951.
- Takahashi, K & Yamanaka, S. (2006). Induction of pluripotent stem cells from mouse embryonic and adult fibroblast cultures by defined factors. *Cell* 126, 4, 663-676.
- Tamayo-Canul, J, Alvarez, M, LÚpez-UrueÓa, E, Nicolas, M, Martinez-Pastor, F, Anel, E, Anel, L & de Paz, P. (2011). Undiluted or extended storage of ram epididymal spermatozoa as alternatives to refrigerating the whole epididymes. *Animal Reproduction Science* 126, 1-2, 76-82.
- Tao, Y, Liu, J, Zhang, Y, Zhang, M, Fang, J, Han, W, Zhang, Z, Liu, Y, Ding, J & Zhang, X. (2009). Fibroblast cell line establishment, cryopreservation and interspecies embryos reconstruction in red panda (*Ailurus fulgens*). *Molecular Ecology* 17, 2, 117-124.
- Tharasanit, T & Techakumphu, M. (2010). The effect of chemical delipidation on cryopreservability of cat embryos. *Reproduction, Fertility and Development* 23, 1, 153 (abstract).
- Thibier, M. (2009). Data Retrieval Committee statistics of embryo transfer - year 2008. The worldwide statistics of embryo transfers in farm animals. *International Embryo Transfer Society Newsletter* 27, 4, 13-19.
- Thomas, CD, Cameron, A, Green, RE, Bakkenes, M, Beaumont, LJ, Collingham, YC, Erasmus, BFN, de Siqueira, MF, Grainger, A, Hannah, L, Hughes, L, Huntley, B, van Jaarsveld, AS, Midgley, GF, Miles, L, Ortega-Huerta, MA, Townsend Peterson, A, Phillips, OL & Williams, SE. (2004). Extinction risk from climate change. *Nature* 427, 6970, 145-148.



- Thomson, JA, Itskovitz-Eldor, J, Shapiro, SS, Waknitz, MA, Swiergiel, JJ, Marshall, VS & Jones, JM. (1998). Embryonic stem cell lines derived from human blastocysts. *Science* 282, 5391, 1145-1147.
- Thundathil, J, Whiteside, D, Shea, B, Ludbrook, D, Elkin, B & Nishi, J. (2007). Preliminary assessment of reproductive technologies in wood bison (*Bison bison athabasca*): Implications for preserving genetic diversity. *Theriogenology* 68, 1, 93-99.
- Thurston, LM, Siggins, K, Mileham, AJ, Watson, PF & Holt, WV. (2002). Identification of amplified restriction fragment length polymorphism markers linked to genes controlling boar sperm viability following cryopreservation. *Biology of Reproduction* 66, 3, 545-554.
- Tilly, JL, Niikura, Y & Rueda, BR. (2009). The current status of evidence for and against postnatal oogenesis in mammals: A case of ovarian optimism versus pessimism? *Biology of Reproduction* 80, 1, 2-12.
- Tourmente, M, Gomendio, M & Roldan, E. (2011). Sperm competition and the evolution of sperm design in mammals. *BMC Evolutionary Biology* 11, 1, 12.
- Toyooka, Y, Tsunekawa, N, Akasu, R & Noce, T. (2003). Embryonic stem cells can form germ cells *in vitro*. *Proceedings of the National Academy of Science of the United States of America* 100, 20, 11457-11462.
- Trimeche, A, Renard, P & Tainturier, D. (1998). A procedure for Poitou jackass sperm cryopreservation. *Theriogenology* 50, 5, 793-806.
- Trounson, A & Kirby, C. (1989). Problems in the cryopreservation of unfertilized eggs by slow cooling in dimethyl sulfoxide. *Fertility and Sterility* 52, 5, 778-786.
- Trounson, A & Mohr, L. (1983). Human pregnancy following cryopreservation, thawing and transfer of an eight-cell embryo. *Nature* 305, 5936, 707-709.
- Tryon, BW & Murphy, JB. (1982). Miscellaneous notes on the reproductive biology of reptiles. 5. Thirteen varieties of the genus *Lampropeltis*, species *mexicana*, *triangulum* and *zonata*. *Transactions of the Kansas Academy of Science* 85, 2, 96-119.
- Uribe, MCA & Guillette, LJ. (2000). Oogenesis and ovarian histology of the American alligator *Alligator mississippiensis*. *Journal of Morphology* 245, 3, 225-240.
- Van Blerkom, J. (1989). Maturation at high frequency of germinal-vesicle-stage mouse oocytes after cryopreservation: alterations in cytoplasmic, nuclear, nucleolar and chromosomal structure and organization associated with vitrification. *Human Reproduction* 4, 8, 883-898.
- Van Thuan, N, Wakayama, S, Kishigami, S & Wakayama, T. (2005). New preservation method for mouse spermatozoa without freezing. *Biology of Reproduction* 72, 2, 444-450.
- Vendramini, OM, Bruyas, JF, Fieni, F, Battut, I & Tainturier, D. (1997). Embryo transfer in Poitou donkeys, preliminary results. *Theriogenology* 47, 1, 409 (abstract).
- Veprintsev, BN & Rott, NN. (1979). Conserving genetic resources of animal species. *Nature* 280, 5724, 633-634.
- von Baer, A, Del Campo, MR, Donoso, X, Toro, F, von Baer, L, Montecinos, S, Rodriguez-Martinez, H & Palasz, T. (2002). Vitrification and cold storage of llama (*Lama glama*) hatched blastocysts. *Theriogenology* 57, 1, 489 (abstract).
- von Schönfeldt, V, Chandolia, R, Kiesel, L, Nieschlag, E, Schlatt, S & Sonntag, B. (2011). Assessment of follicular development in cryopreserved primate ovarian tissue by

- xenografting: prepubertal tissues are less sensitive to the choice of cryoprotectant. *Reproduction* 141, 4, 481-490.
- Wakayama, T & Yanagimachi, R. (1998). Development of normal mice from oocytes injected with freeze-dried spermatozoa. *Nature Biotechnology* 16, 7, 639-641.
- Wake, DB & Vredenburg, VT. (2008). Colloquium paper: are we in the midst of the sixth mass extinction? A view from the world of amphibians. *Proceedings of the National Academy of Science of the United States of America* 105 Suppl 1, 11466-11473.
- Walmsley, R, Cohen, J, Ferrara-Congedo, T, Reing, A & Garrisi, J. (1998). The first births and ongoing pregnancies associated with sperm cryopreservation within evacuated egg zona. *Human Reproduction* 13, suppl 4, 61-70.
- Walpole, M, Almond, REA, Besancon, C, Butchart, SHM, Campbell-Lendrum, D, Carr, GM, Collen, B, Collette, L, Davidson, NC, Dulloo, E, Fazel, AM, Galloway, JN, Gill, M, Goverse, T, Hockings, M, Leaman, DJ, Morgan, DHW, Revenga, C, Rickwood, CJ, Schutysse, F, Simons, S, Stattersfield, AJ, Tyrrell, TD, Vie, J-C & Zimsky, M. (2009). Tracking progress toward the 2010 biodiversity target and beyond. *Science* 325, 5947, 1503-1504.
- Wang, X, Chen, H, Yin, H, Kim, SS, Lin Tan, S & Gosden, RG. (2002). Fertility after intact ovary transplantation. *Nature* 415, 6870, 385.
- Ward, MA, Kaneko, T, Kusakabe, H, Biggers, JD, Whittingham, DG & Yanagimachi, R. (2003). Long-term preservation of mouse spermatozoa after freeze-drying and freezing without cryoprotection. *Biology of Reproduction* 69, 6, 2100-2108.
- Weissman, A, Gotlieb, L, Colgan, T, Jurisicova, A, Greenblatt, EM & Casper, RF. (1999). Preliminary experience with subcutaneous human ovarian cortex transplantation in the NOD-SCID mouse. *Biology of Reproduction* 60, 6, 1462-1467.
- Whittingham, DG. (1971). Survival of mouse embryos after freezing and thawing. *Nature* 233, 5315, 125-126.
- Whittingham, DG. (1975). Survival of rat embryos after freezing and thawing. *Journal of Reproduction and Fertility* 43, 3, 575-578.
- Whittingham, DG. (1977). Fertilization *in vitro* and development to term of unfertilized mouse oocytes previously stored at -196°C. *Journal of Reproduction and Fertility* 49, 1, 89-94.
- Whittingham, DG & Adams, CE. (1974). Low temperature preservation of rabbit embryos. *Cryobiology* 11, 6, 560-561 (abstract).
- Whittingham, DG & Adams, CE. (1976). Low temperature preservation of rabbit embryos. *Journal of Reproduction and Fertility* 47, 2, 269-274.
- Whittingham, DG, Leibo, SP & Mazur, P. (1972). Survival of mouse embryos frozen to -196° and -269°C. *Science* 178, 4059, 411-414.
- Whittington, K & Ford. (1999). Relative contribution of leukocytes and of spermatozoa to reactive oxygen species production in human sperm suspensions. *International Journal of Andrology* 22, 4, 229-235.
- Wildt, DE. (1992). Genetic resource banks for conserving wildlife species: justification, examples and becoming organized on a global basis. *Animal Reproduction Science* 28, 1-4, 247-257.
- Wildt, DE, Schiewe, MC, Schmidt, PM, Goodrowe, KL, Howard, JG, Phillips, LG, O'Brien, SJ & Bush, M. (1986). Developing animal model systems for embryo technologies in rare and endangered wildlife. *Theriogenology* 25, 1, 33-51.

- Willadsen, S, Polge, C & Rowson, LEA. (1978). The viability of deep-frozen cow embryos. *Journal of Reproduction and Fertility* 52, 2, 391-393.
- Willadsen, SM, Polge, C, Rowson, LEA & Moor, RM. (1974). Preservation of sheep embryos in liquid nitrogen. *Cryobiology* 11, 6, 560 (abstract).
- Willadsen, SM, Polge, C, Rowson, LEA & Moor, RM. (1976). Deep freezing of sheep embryos. *Journal of Reproduction and Fertility* 46, 1, 151-154.
- Wilmot, I. (1972). The effect of cooling rate, warming rate, cryoprotective agent and stage of development of survival of mouse embryos during freezing and thawing. *Life Sciences* 11, 22, Part 2, 1071-1079.
- Wilmot, I & Rowson, LE. (1973). Experiments on the low-temperature preservation of cow embryos. *The Veterinary Record* 92, 26, 686-690.
- Wilmot, I, Schnieke, AE, McWhir, J, Kind, AJ & Campbell, KH. (1997). Viable offspring derived from fetal and adult mammalian cells. *Nature* 385, 6619, 810-813.
- Wolf, DP, Vandervoort, CA, Meyer-Haas, GR, Zelinski-Wooten, MB, Hess, DL, Baughman, WL & Stouffer, RL. (1989). *In vitro* fertilization and embryo transfer in the rhesus monkey. *Biology of Reproduction* 41, 2, 335-346.
- Wolfe, BA & Wildt, DE. (1996). Development to blastocysts of domestic cat oocytes matured and fertilized *in vitro* after prolonged cold storage. *Journal of Reproduction and Fertility* 106, 1, 135-141.
- Wolvekamp, MC, Cleary, ML, Cox, SL, Shaw, JM, Jenkin, G & Trounson, AO. (2001). Follicular development in cryopreserved common wombat ovarian tissue xenografted to nude rats. *Animal Reproduction Science* 65, 1-2, 135-147.
- Wood, TC, Montali, RJ & Wildt, DE. (1997). Follicle-oocyte atresia and temporal taphonomy in cold-stored domestic cat ovaries. *Molecular Reproduction and Development* 46, 2, 190-200.
- Wood, TC & Wildt, DE. (1997). Effect of the quality of the cumulus-oocyte complex in the domestic cat on the ability of oocytes to mature, fertilize and develop into blastocysts *in vitro*. *Journal of Reproduction and Fertility* 110, 2, 355-360.
- Woods, EJ, Newton, L & Critser, JK. (2010). A novel closed system vial with sentinel test segment for sperm cryopreservation. *Fertility and Sterility* 94, 4, Supplement 1, S239-S239.
- Woods, GL, White, KL, Vanderwall, DK, Li, GP, Aston, KI, Bunch, TD, Meerdo, LN & Pate, BJ. (2003). A mule cloned from fetal cells by nuclear transfer. *Science* 301, 5636, 1063.
- Xu, Y-N, Cui, X-S, Sun, S-C, Jin, Y-X & Kim, N-H. (2011). Cross species fertilization and development investigated by cat sperm injection into mouse oocytes. *Journal of Experimental Zoology Part A: Ecological Genetics and Physiology* 315A, 6, 349-357.
- Yamamoto, Y, Oguri, N, Tsutsumi, Y & Hachinohe, Y. (1982). Experiments in the freezing and storage of equine embryos. *Journal of Reproduction and Fertility Supplement* 32, 399-403.
- Yamauchi, Y, Shaman, JA & Ward, WS. (2011). Non-genetic contributions of the sperm nucleus to embryonic development. *Asian Journal of Andrology* 13, 1, 31-35.
- Yang, C-R, Miao, D-Q, Zhang, Q-H, Guo, L, Tong, J-S, Wei, Y, Huang, X, Hou, Y, Schatten, H, Liu, Z & Sun, Q-Y. (2010). Short-term preservation of porcine oocytes in ambient temperature: Novel approaches. *PLoS One* 5, 12, e14242.

- Yavin, S, Aroyo, A, Roth, Z & Arav, A. (2009). Embryo cryopreservation in the presence of low concentration of vitrification solution with sealed pulled straws in liquid nitrogen slush. *Human Reproduction* 24, 4, 797-804.
- Yeoman, RR, Gerami-Naini, B, Mitalipov, S, Nusser, KD, Widmann-Browning, AA & Wolf, DP. (2001). Cryoloop vitrification yields superior survival of Rhesus monkey blastocysts. *Human Reproduction* 16, 9, 1965-1969.
- Yeoman, RR, Wolf, DP & Lee, DM. (2005). Coculture of monkey ovarian tissue increases survival after vitrification and slow-rate freezing. *Fertility and Sterility* 83, 4, Supplement 1, 1248-1254.
- Yin, H, Wang, X, Kim, SS, Chen, H, Tan, SL & Gosden, RG. (2003). Transplantation of intact rat gonads using vascular anastomosis: effects of cryopreservation, ischaemia and genotype. *Human Reproduction* 18, 6, 1165-1172.
- Yu, I & Leibo, SP. (2002). Recovery of motile, membrane-intact spermatozoa from canine epididymides stored for 8 days at 4°C. *Theriogenology* 57, 3, 1179-1190.
- Yushchenko, NP. (1957). Proof of the possibility of preserving mammalian spermatozoa in a dried state. *Proceedings of the Lenin Academy of Agricultural Sciences of the USSR* 22, 37-40.
- Zambelli, D, Prati, F, Cunto, M, Iacono, E & Merlo, B. (2008). Quality and *in vitro* fertilizing ability of cryopreserved cat spermatozoa obtained by urethral catheterization after medetomidine administration. *Theriogenology* 69, 4, 485-490.
- Zeilmaker, GH, Alberda, AT, van Gent, I, Rijkmans, CM & Drogendijk, AC. (1984). Two pregnancies following transfer of intact frozen-thawed embryos. *Fertility and Sterility* 42, 2, 293-296.
- Zeng, W, Avelar, GF, Rathi, R, Franca, LR & Dobrinski, I. (2006). The length of the spermatogenic cycle is conserved in porcine and ovine testis xenografts. *Journal of Andrology* 27, 4, 527-33.
- Zeron, Y, Pearl, M, Borochoy, A & Arav, A. (1999). Kinetic and temporal factors influence chilling injury to germinal vesicle and mature bovine oocytes. *Cryobiology* 38, 1, 35-42.
- Zeron, Y, Tomczak, M, Crowe, J & Arav, A. (2002). The effect of liposomes on thermotropic membrane phase transitions of bovine spermatozoa and oocytes: implications for reducing chilling sensitivity. *Cryobiology* 45, 2, 143-152.
- Zhang, T & Rawson, DM. (1995). Studies on chilling sensitivity of zebrafish (*Brachydanio rerio*) embryos. *Cryobiology* 32, 3, 239-246.
- Zhang, T & Rawson, DM. (1996). Feasibility studies on vitrification of intact zebrafish (*Brachydanio rerio*) embryos. *Cryobiology* 33, 1, 1-13.
- Zuckerman, S. (1951). The number of oocytes in the mature ovary. *Recent Progress in Hormon Research* 6, 1, 63-109.

# Wildlife Cats Reproductive Biotechnology

Regina Celia Rodrigues da Paz

*Departamento de Ciências Básicas e Produção Animal,  
Faculdade de Agronomia, Medicina Veterinária e Zootecnia,  
Universidade Federal de Mato Grosso – DCBPA/FAMEV/UFMT  
Brazil*

## 1. Introduction

The techniques used in assisted reproduction for wildlife or domestic animals are similar, and consist in the collection, evaluation, and cryopreservation of semen; artificial insemination (AI), *in vitro* fertilization (IVF), and embryo transfer (ET).

Considering that the maintenance of genetic diversity is reproduction dependent, reproduction technologies are important tools for the preservation of endangered species, through the development of methods to increase the fertility in these animals (Howard, 1993).

Several studies show that hormone therapies may induce ovulation and/or superovulation in wild animals (Pope, 2000). The artificial induction of ovulation and superovulation are important components in assisted reproduction techniques, especially in cats, because their ovulation is induced by external stimulations (Hamner et al., 1970).

According to The World Zoo Conservation Strategy ([IUDZG/CBSG], 1993), some of the many benefits from using assisted reproduction techniques in conservation management programs are:

1. To enable the exchange of genetic material between two or more zoos collaborating in the same program, including animals in captivity and in the wild. Semen transportation is economical and reduces the risks involved in animal transfers and consequently diseases transmission;
2. To enable reproduction in animals with physical and reproductive behavioral disabilities. This is important for animals that are representative of genetic lines that cannot be lost;
3. To enable rapid population growth when only a small founder population is available;
4. To assist in maintaining the ratio between males and females by selectively transplanting embryos of one sex;
5. To determine the number of offspring per individual;
6. To promote the formation of databases for gametes and embryos from species of interest.

The reproductive techniques used for domestic animals are gradually being used for zoo animals (Comizzoli et al., 2000; Dresser et al., 1986).

Artificial insemination has been conducted in different species of carnivores such as cougar (*Felis concolor*), leopard (*Panthera pardus saxicolor*), cheetah (*Acinonyx jubatus*), tiger (*Panthera tigris altaica*), ocelot (*Leopardus pardalis*), tigrina (*Leopardus tigrinus*), and jaguar (*Panthera onca*) (Dresser et al., 1982; Donoghue et al., 1993, Howard et al., 1992a; Jimenez et al., 1999; Moore et al., 1981; Moraes et al., 1997; Silva et al., 2000; Swanson et al., 1996a).

*In vitro* fertilization (IVF) has also been performed in captive wild cats such as tiger (*Panthera tigris altaica*), jaguar (*Panthera onca*), ocelot (*Leopardus pardalis*) and tigrina (*Leopardus tigrinus*) (Donoghue et al., 1990; Morato et al., 2000; Swanson & Brown, 2004).

The application of artificial reproductive methods in wild animals has not been successful, showing low reproductive rates. Some of the several reasons for these low reproductive rates are lack of knowledge on the species' physiology, poor sperm or oocytes quality, and difficulties in adapting from the methodologies used in experimental models.

Considering the zoos' limitation to maintain genetically viable populations of threatened species, the establishment of genetic banks containing semen, oocytes, embryos and cells emerge as a strategy to ensure the genetic diversity of populations (Lasley et al., 1994). The potential of assisted reproduction for endangered species should be emphasized by the possibility of semen and embryos cryopreservation, which are genetically valuable for the future populations.

Although there are some records related to the female reproductive physiology (Table 1) and semen characteristics for various Neotropical felids species (Table 2), there is a little knowledge about the fertilization ability using artificial methods (Table 3) in these animals. Studies about the application of assisted reproduction techniques in Neotropical felids showed limitations because of the lack of basic knowledge on the physiology of the species.

## 2. General reproductive characteristics in wildlife cats

The large number of felines and their wide geographical distribution determine many of the species' particularities, mainly in the reproductive aspects. The reproductive seasonality is one of the most variable aspect between species.

In domestic cats (*Felis catus*), the reproductive seasonality is related to photoperiod (Johnston et al., 1996; Shille et al., 1979; Tsuitsui & Stabenfeldt, 1996), whereas in wild animals, it is also related to high or low food supply during the seasons (Ewer, 1975).

The ovulation mechanism is another variable aspect among cat species. Studies evaluating serum hormone levels confirmed that some wild cats like tiger (*Panthera tigris*) (Seal et al., 1985), snow leopard (*Panthera uncia*) (Schmidt et al., 1993), jaguars (*Panthera onca*) (Wildt et al., 1979) and cougars (*Puma concolor*) (Bonney et al., 1981), have induced reflex ovulation, similar to the domestic cat (Johnston et al., 1996; Shille et al., 1979; Tsuitsui & Stabenfeldt, 1996).

However, female leopards (*Panthera pardus*) presented two ovulation mechanisms in two different situations. When kept isolated, they showed typical hormonal profile for ovulation reflex mechanism; but, when housed in pairs with another female, the ovulation was probably stimulated by physical contact (Schmidt et al., 1988).

Lionesses (*Panthera leo*), when isolated from the males, showed an ovulation pattern distinct from other cats. Schmidt et al. (1979), using serum hormone levels and corpus luteum

visualization, demonstrated that this species presents spontaneous ovulation in a higher frequency compared to what is described for other felines.

The genus *Leopardus* is polyestral and can cycle all year round (Morais et al., 1996; Moreira et al., 2001); the margay (*Leopardus wiedii*) is the only species in this genus presenting spontaneous ovulation (Moreira et al., 2001).

According to Tebet (1999), the estrous cycle in ocelots is characterized by the presence of serum estradiol peaks associated with relatively low levels of serum progesterone (<2.61 ng/mL). This demonstrates the polyestral characteristic of this species, similar to previously observed for other species such as cats (Shille et al., 1979; Tsuitsui & Stabenfeldt, 1996; Verhage et al., 1976), tigers (Seal et al., 1985), and cheetahs (Brown et al., 1996).

Ocelot females that ovulated and were not fertilized showed a period of increased progesterone serum concentration and estrus inhibition (Tebet, 1999), called pseudopregnancy or diestrus, similar to domestic cats (Feldman & Nelson, 1996) and leopards (Schmidt et al., 1988).

Under an evolutionary analysis and among other factors, the process of spontaneous or induced ovulation may be related to the sociability of the species. Thus, solitary cats would require a longer estrus period, extended viability of oocytes, and extended time for the ovulation to occur, after the couple meet in the wild (Ewer, 1975).

The detection of fecal estrogens and progestins, through the analyses of fecal metabolites in domestic and wild cats such as the leopard cat (*Felis bengalensis*), cheetah (*Acinonyx jubatus*), clouded leopard (*Neofelis nebulosa*), and snow leopard (*Panthera uncia*) was successfully performed by Brown et al. (1994). Likewise, this methodology has been widely used to monitor ovarian function in Neotropical felines such as the ocelot and margay (Morais et al., 1996; Moreira et al., 2001).

In this context, noninvasive methods such as the quantification of fecal hormonal metabolites are increasingly being used in wildlife animals.

The estrus cycle, gestational time, and number of pups observed in different species of Neotropical wild cats are presented in Table 1.

Common Name	Scientific Name	Estrus (days)	Estrous Cycle (days)	Gestation (days)	Pups (n°)
Ocelot	<i>Leopardus pardalis</i>	4.63±0.63 <sup>1</sup>	16.5 ± 1.5 <sup>2</sup> 18.4±1.6 <sup>4</sup>	70-85 <sup>6</sup>	1-4 <sup>6</sup>
Tigrinus	<i>Leopardus tigrinus</i>	3.0-9.0 <sup>5</sup>	15.8 ± 1.5 <sup>2</sup> 16.7±1.3 <sup>4</sup>	73-78 <sup>6</sup>	1-4 <sup>6</sup>
Margay	<i>Leopardus wiedii</i>	4.0-10.0 <sup>5</sup>	19.5 ± 2.1 <sup>2</sup> 17.6±1.5 <sup>4</sup>	81-84 <sup>6</sup>	1 <sup>6</sup>
Geoffroy's cat	<i>Oncifelis geoffroyi</i>	2.5±0.5 <sup>1</sup>	20.0 <sup>5</sup>	72-76 <sup>6</sup>	1-3 <sup>6</sup>

Common Name	Scientific Name	Estrus (days)	Estrous Cycle (days)	Gestation (days)	Pups (n <sup>o</sup> )
Pallas cat	<i>Oncifelis colocolo</i>	-	-	80-85 <sup>6</sup>	1-3 <sup>6</sup>
Jaguarondi	<i>Herpaelurus yaguarundi</i>	3.17±0.75 <sup>1</sup>	53.63±2.41 <sup>1</sup>	72-75 <sup>6</sup>	1-4 <sup>6</sup>
Puma	<i>Puma concolor</i>	8.0 <sup>5</sup>	23.0 <sup>5</sup>	84-98 <sup>6</sup>	1-6 <sup>6</sup>
Jaguar	<i>Panthera onca</i>	12.0±1.0 <sup>3</sup>	47.2±5.4 <sup>3</sup>	90-111 <sup>6</sup>	1-2 <sup>6</sup>

Mellen 1989<sup>1</sup>; Morais et al., 1996<sup>2</sup>; Morato & Paz, 2001<sup>3</sup>; Moreira et al., 2001<sup>4</sup>; Oliveira, 1994<sup>5</sup>; Oliveira & Cassaro, 1997<sup>6</sup>.

Table 1. Neotropical wildlife cats reproductive characteristics.

### 3. Sperm collection

Two methods are used for the collection of semen from wild animals: the first is the epididymis' semen collection from dead animals or after castration or vasectomy. The second is through an artificial vagina, electroejaculation, or digital manipulation.

#### 3.1 Post mortem sperm collection

In the post mortem sperm collection, immediately after death or castration, the testes should be kept cold at 5°C (Howard, 1993). Generally, postmortem epididymidal spermatozoa remain viable for several days after the animal's death. However, this period depends on the species, the storage conditions of the testes, and methods used for sperm collection. Several techniques could be used including: totally cutting (homogenization) the cauda epididymis; washing out or aspiration (flushing) through sperm duct; making cuts (mincing) in the cauda epididymis and squeezing of content; or just squeezing (pressing). The first two techniques are the most frequently used (Maksudov et al., 2008).

For cats, the epididymis is washed and homogenized in HEPES medium plus Ham's F10, and the sperm is recovered after centrifugation. Live sperm can be recovered within the first twelve hours of the epididymis isolation using this technique (Howard, 1993). In vasectomized animals, the semen is collected by aspiration from the epididymis' tail using syringe and needle. The syringe should contain HEPES medium plus HAM'S F10 and the sperm is recovered after centrifugation.

Sperm recovered from the epididymis of cats are known to be motile, viable, and capable of penetrating oocytes (Goodrowe & Hay, 1993; Hay & Goodrowe, 1993). However, epididymal sperm have naturally more cytoplasmic droplets, which normally are lost during transport through the duct (Briz et al., 1995).

According to Tebet et al. (2006) there were no significant differences between the fresh or frozen-thawed domestic cat spermatozoa for the variables: sperm motility, plasma membrane integrity and morphology of electroejaculated and epididymal spermatozoa analyzed immediately after collection, and after freezing and thawing. Jewgenow (Jewgenow et al., 1997) reported motility of frozen-thawed epididymal sperm of lions (*Panthera leo*), tigers (*Panthera tigris*), leopards (*Panthera pardus*), pumas (*Felis concolor*) and jaguar (*Panthera onca*).



Epididymal spermatozoa were collected from immobilized adult male lion by caudal epididymectomy, cryopreserved, and used for IVF of *in vitro* matured lionesses' ova. The post-thawed motility ranged from 55-65%, and the percentages of fertilized ova were 12.7% and 11.5% for 30 and 36 hours of *in vitro* maturation, respectively (Bartels et al., 2000).

It has been shown, for several species, that the methods developed for ejaculated sperm are effective for freezing epididymal spermatozoa. However, the physiology of ejaculated and epididymal spermatozoa are different thus, it can be assumed that optimum methods of freezing and thawing may be different.

Postmortem material that can be retrieved in zoos usually belonged to the aged animals with different diseases or that died because of accidents (stress, fights). Moreover, some species display seasonal breeding. All these factors can influence on the spermatozoa's presence and quality in epididymis, at the collection time (Maksudov et al., 2008).

Analysis of different factors showed that the concurrency of death with breeding season has the strongest affect on the spermatozoa content in testicles of dead animals. The spermatozoa content and quality were almost equal in males that died of sickness (cancer, chronic cardiovascular or excretory system disorders) and in males that died in accidents (stress, fights). However, the quality of postmortem semen of animals that died of natural death is worse than that of animals that died accidentally (Maksudov et al., 2008).

The energy invested by a male with copulation is minimal compared to that of the female, for whom the costs continue throughout pregnancy and lactation. Therefore, it is a significant genetic advantage for cats to be reproductively active throughout the year, or at least to remain active well outside of the usual female breeding season (Spindler & Wildt, 1999).

This strategy is apparent in wild felids. The female Siberian tiger exhibits more estrual activity in January-June than at any other time of the year (Seal et al., 1985), however, the sperm quality is fairly consistent throughout the year (Byers et al., 1990). The quantity and quality of the sperm from some felids can vary when a distinctive female reproductive seasonality is known, as in the snow leopard (Johnston et al., 1994) and Pallas' cat (Swanson et al., 1996), the males remains reproductively active for longer periods than the females of the same species.

The collection of the postmortem sperm of recently dead animals belonging to endangered species can be of substantial importance, and therefore, the method of choice for the preservation of reproductive cells, in the wild, at zoos, and in national parks. The preservation and utilization of postmortem represent the last chance to obtain offspring from the dead males in cases of unexpected loss of valuable animals (Maksudov et al., 2008).

### 3.2 In vivo sperm collection

The collection of semen, through digital manipulation or using an artificial vagina are indicated because they promote a natural and normal ejaculation, however, these methods require intensive animal training. These techniques are effective for wild dogs, but not routinely used in wild cats.

The electroejaculation is the most used method in wild cats because it can be performed in anesthetized animals. However, one of the disadvantages of using this method in cats is the urine contamination of the semen. The urine contamination occurs when the voltage exceeds the minimum necessary level for ejaculation or when the electrode is positioned cranially. One alternative to minimize this problem would be the catheterization or cystocentesis before start procedure.

The Tiletamine-Zolazepam combination has been the most used anesthetic protocol for this procedure because it produces insignificant changes in the ejaculate. The ketamine hydrochloride and xylazine association in the same syringe has been used for semen collection in small cats, but according to Dooley et al. (1991), these drugs, in combination, seems to be related to retrograde ejaculation.

The electroejaculator should indicate both the voltage and amperage. The voltage should reach up to 12V, controlled by the command button, which should provide smooth control and gradual increase in power output.

The rectal bipolar electrode used for electroejaculation should have three longitudinal strips of copper. The copper strips must have a 0.4 cm apart and protruding approximately 0.2 cm. The electrode, previously lubricated with mineral oil, should be introduced into the rectum with the longitudinal strips ventrally positioned, applying light pressure to increase contact with the pelvic plexus region. The diameter of the electrode should be specific to each species (Table 2).

The electrical series follows a specific protocol with 80 stimuli divided into three series: 30 (series 1: 10 stimuli at 2, 3 and 4V), 30 (Series 2: 10 stimulations in 3, 4 and 5V) and 20 (series 3: 10 stimulations in 4 and 5V) (Howard 1993). In jaguars, the last series of stimuli can reach up to 6V to achieve ejaculation (Paz et al., 2000).

The stimulation cycle starts at 1 second from 0 voltage to the desired voltage, 2 to 3 seconds at the desired voltage, and 3 seconds returning to 0 voltage. An interval of 10 minutes should be used for resting between sets.

Before the start of the series, the penis must be exposed, examined, and washed with saline solution and gauze. The semen collection should be performed in plastic tubes that are maintained warm at 37° C water bath. For each series, the tubes should be replaced in order to avoid urine contamination. All ejaculates should be used; the total volume of semen is the sum of each ejaculate's volume (Figure 1).

#### **4. Sperm evaluation**

The appearance is the first evaluation of the semen: changes in color may be associated with diseases in the accessory organs and testes. The ejaculate's volume is the second aspect to be evaluated and must be determined immediately after collection. The volume provides information about the semen production in different species. The pH determination is important because it may indicate urine (acidic pH) or bacteria contamination (basic pH).

For sperm evaluation, an aliquot of the ejaculate is placed on a microscope slide warmed at 37°C, covered with a warmed glass coverslip, and examined at 400 X magnification. The

semen should be evaluated for motility and progressive sperm motility. Motility is expressed in percentages, with 0% being the value for immobile spermatozoa and 100% for maximum spermatozoa performance. The sperm type of movement is evaluated by the progressive sperm motility in scale from 0 to 5 (0 - no motility, 1 - poor lateral movement with some progression, 2 - moderate lateral movement with occasional progression, 3 - slow progression, 4 - progression, 5 - rapid progression) (Howard, 1993).



Fig. 1. Ocelot's penis exposed before semen collection; the penis' spines can be observed (left). Ocelot's electroejaculation procedure (right). Pictures: Regina Paz.

The sperm morphology and concentration can be evaluated by fixing an aliquot of semen (1:3 dilution) in a 10% formaldehyde saline solution or in a 2.5% glutaraldehyde solution after the preparation of samples in a humidified chamber.

For the determination of the sperm morphology, 200 cells per slide were counted at 1000 X magnification under light microscopy; the abnormalities were classified as primary or secondary defects expressed as percentages. According to the primary defects presented in the sample, the sperm can be classified as macrocephalic, microcephalic, bicephalic, pyriform head, rounded head, abnormal acrosome, abnormal midpiece, no midpiece, tightly coiled tail and biflagelate. According to the secondary defects presented in the sample, the sperm can be classified as bent midpiece with or without droplet, bent tail with or without droplet, and proximal or distal droplet.

The concentration can be evaluated using a Neubauer chamber at 400 X magnification under light microscopy. The volume, concentration, motility, vigor and abnormal sperm data in different species are presented in Table 2.

Species	Probe (cm)	N° Ejaculates	Volume (mL)	Concentr. (x10 <sup>6</sup> /mL)	Motility (%)	Vigour (0-5)	Normals (%)
<i>Ocelot</i> ( <i>L. pardalis</i> )	1.0 <sup>1</sup>	5 <sup>1</sup> 38 <sup>2</sup>	0.3±0.1 <sup>1</sup> 0.62±0.08 <sup>2</sup>	28.0±17.0 <sup>1</sup> 53.8±17.8 <sup>2</sup>	72.0±12.5 <sup>1</sup> 70.4±2.3 <sup>2</sup>	4.0±0.5 <sup>1</sup> -	80.8±0.9 <sup>1</sup> 58.4±5.8 <sup>2</sup>
<i>Tigrinus</i> ( <i>L. tigrinus</i> )	1.0 <sup>1</sup>	18 <sup>2</sup>	0.11±0.02 <sup>2</sup>	78.5±33.8 <sup>2</sup>	62.1±5.7 <sup>2</sup>	-	35.6±6.0 <sup>2</sup>
<i>Margay</i> ( <i>L. wiedii</i> )	1.0 <sup>1</sup>	11 <sup>1</sup> 27 <sup>2</sup>	0.2±0.1 <sup>1</sup> 0.31±0.05 <sup>2</sup>	79.9±28.1 <sup>1</sup> 14.2±5.3 <sup>2</sup>	86.0±3.3 <sup>1</sup> 62.8±5.3 <sup>2</sup>	4.6±0.2 <sup>1</sup> -	48.5±6.1 <sup>1</sup> 39.5±7.7 <sup>2</sup>
<i>Jaguarondi</i> ( <i>H. yagouarundi</i> )	1.0 <sup>1</sup>	3 <sup>1</sup> 21 <sup>2</sup>	0.1±0.1 <sup>1</sup> 0.08±0.02 <sup>2</sup>	12.5±9.4 <sup>1</sup> 7.2±4.0 <sup>2</sup>	50.0±9.9 <sup>1</sup> 57.8±2.5 <sup>2</sup>	3.5±0.4 <sup>1</sup> -	35.4±14.3 <sup>1</sup> 25.7±4.6 <sup>2</sup>
<i>Pampas cat</i> ( <i>O. colocolo</i> )	1.0 <sup>1</sup>	5 <sup>1</sup> 2 <sup>2</sup>	0.3±0.1 <sup>1</sup> 0.08±0.01 <sup>2</sup>	10.8±5.7 <sup>1</sup> 364.0±326.0 <sup>2</sup>	36.7±6.6 <sup>1</sup> 81.3±6.3 <sup>2</sup>	2.8±0.2 <sup>1</sup> -	65.9±23.8 <sup>1</sup> 56.5±0.5 <sup>2</sup>
<i>Geofroy's cat</i> ( <i>O. geofroy</i> )	1.0 <sup>1</sup>	8 <sup>1</sup> 24 <sup>2</sup>	0.2±0.1 <sup>1</sup> 0.21±0.03 <sup>2</sup>	300.0±233.2 <sup>1</sup> 66.5±24.4 <sup>2</sup>	73.0±4.4 <sup>1</sup> 64.0±4.7 <sup>2</sup>	4.0±0.3 <sup>1</sup> -	29.0±11.5 <sup>1</sup> 46.9±5.0 <sup>2</sup>
<i>Puma</i> ( <i>P. concolor</i> )	1.6 <sup>1</sup>	12 <sup>1</sup>	2.8±0.5 <sup>1</sup>	20.2±4.7 <sup>1</sup>	52.0±8.0 <sup>1</sup>	3.5±0.2 <sup>1</sup>	23.4±3.7 <sup>1</sup>
<i>Jaguar</i> ( <i>P. onca</i> )	3.0 <sup>1</sup> 2.3 <sup>3</sup>	5 <sup>1</sup> 38 <sup>3</sup>	2.7±0.6 <sup>1</sup> 5.7±1.71 <sup>3</sup>	12.0±1.9 <sup>1</sup> 13.16±10.76 <sup>3</sup>	82.0±5.8 <sup>1</sup> 56.9±9.35 <sup>3</sup>	4.1±0.3 <sup>1</sup> 3.02±0.77 <sup>3</sup>	58.2±11.1 <sup>1</sup> 65.73±6.7 <sup>3</sup>

Howard, 1993<sup>1</sup>; Morais, 2001<sup>2</sup>; Paz et al., 2000<sup>3</sup>;

Table 2. Neotropical wildlife cats seminal characteristics.

The poor semen quality in carnivores may be related to the nutritional status of the animals. Rodrigues da Paz et al. (2006), studying the reproduction of jaguars, observed a positive correlation between the improvement in the semen quality and the decrease of primary defects, after diet supplementation with vitamins and minerals. Ocelots, tigrinus and margays showed an increase in the number of ejaculates and 20-30% improvement related to sperm defects after receiving vitamin and mineral supplementation (Morais, 2001).

The seminal plasma constituents compromise the sperm viability in some species. Thus, washing the ejaculates in culture media (HEPES, HAM'SF-10) by centrifugation is efficient in removing the seminal plasma, which could contain bacteria and other undesirable microorganisms, especially when the semen will be used for intrauterine artificial insemination.

## 5. Sperm cryopreservation

The semen cryopreservation procedures should be initiated only after the centrifugation at 300g for 10 minutes in culture medium or HEPES HAM'SF-10. This procedure is essential for eliminating microorganisms and seminal plasma remove.

The "Double Step" cryopreservation method, using glycerol as cryoprotectant, is in general, used for the semen of most carnivores. This method use two fractions: fraction A containing nutritional constituents and antibiotics; and fraction B containing nutritional constituents, antibiotics, and the cryoprotectant. The PDV medium is used for the semen cryopreservation of the majority of wildlife cats. The fraction A contains 20% egg yolk, 11% lactose, 1000 IU penicillin/mL, 1000 mg streptomycin/mL; the fraction B contains 20% egg yolk, 11% lactose, 8% glycerol, 1000 IU penicillin/mL and 1000 mg streptomycin/mL.

After being removed from liquid nitrogen, the semen straws should be immediately thawed for 1 min in waterbath at 37°C, evaluated for total motility (%) and progressive sperm motility (scale, 0-5) before use.

The first step in the process of freezing semen is the removal of the supernatant after centrifugation of the semen collected in HAM'S F-10 or HEPES culture media, and the subsequent resuspension of the pellet in PDV fraction A at 37 °C. This mixture should be kept in the refrigerator for 2 hours followed by a subsequent slow addition of the PDV fraction B. The material is then transferred to cooled 0.25 mL straws and kept in the refrigerator for 30 minutes. Afterwards, each straw is placed in liquid nitrogen vapor for 20 min, immersed in liquid nitrogen, transferred to the racks, and loaded into the canisters for long-term liquid nitrogen storage at -196°C.

The straws, racks and canister identification are extremely important, being the determining factor for the germplasm bank establishment and successful operation. The material collected might be extremely valuable for populations in the future and the safety use of this material depends to the correct identification.

The straws identification must contain the animal species (scientific name), tattoo or microchip number, the institution to which the animal belongs, and the date. For free-living animals, the straws must contain the species, the location where the animal was captured, and the date. The racks may be identified by numbers or if applicable, by species. A registry, which can be computerized, is essential to record all of the straws, racks, and canisters, thereby facilitating the location of the material.

The reasons for the poor quality of wildlife semen after thawing are still unknown and involve a range of information and specific characteristics for each species, which are also not yet clearly understood. New tests with different protocols and different cryoprotectors for each species of interest are required in order to maximize the spermatozoa viability after cryopreservation procedures.

## 6. Ovarian activity induction and superovulation

The currently used ovarian stimulation and superovulation protocols require injections of exogenous gonadotropins, which consist of large complexes of glycoproteins. Equine Chorionic Gonadotropin (eCG) and Human Chorionic Gonadotrophin (hCG) are frequently used due to their long half-life in circulation (24-48h) and good ovarian response with a single application. Other hormones used are the porcine Follicle Stimulating Hormone (pFSH) and porcine Luteinizing Hormone (pLH), these hormones are characterized as short half-life (~ 2h) gonadotropins, therefore, they present the disadvantage of requiring multiple applications to produce a good ovarian response (Crichton et al., 2003; Dresser et al., 1988; Pope, 2000; Wildt et al., 1981).

Studies on wild cats report the use of eCG/hCG in combination, mainly to avoid the stress associated with multiple injections of FSH (Roth et al., 1997). However, the use of porcine FSH/LH determined equivalent number of oocytes compared to the established protocol for eCG/hCG used in tigers (*Panthera tigris*) (Crichton et al., 2000), ocelot (*Leopardus pardalis*) and tigrinas (*Leopardus tigrinus*) (Paz et al., 2005, 2006), demonstrating that the stress caused by daily injections did not influence the ovarian response.

The eCG/hCG combination has been used successfully in tigers (*Panthera tigris*), cheetahs (*Acinonyx jubatus*), clouded leopards (*Neofelis nebulosa*), pumas (*Puma concolor*), ocelots (*Leopardus pardalis*) and tigrinas (*Leopardus tigrinus*) (Barone et al., 1994; Donoghue, 1993; Donoghue et al., 1990; Howard, 1992b; Moore et al., 1981; Moraes et al., 1997; Morato et al., 2000; Swanson, 1996a). The FSH and hCG combination was used successfully in the Indian desert leopard (*Felis sylvestris ornata*) (Pope et al., 1989), and the pFSH and pLH combination in tigers (Crichton et al., 2000, 2003) jaguars (*Panthera onca*) (Morato et al., 2000), ocelots (*Leopardus pardalis*) and tigrinas (*Leopardus tigrinus*) (Paz et al., 2005, 2006).

Swanson et al. (1995, 1996a) suggest that the repeated administration of exogenous gonadotropins, within short time intervals is a problem because it causes a reduction in the ovarian stimulation which is immunologically mediated. The repeated administration of exogenous gonadotropins has been associated with the production of neutralizing immunoglobulin, which prevents the ovarian response to superovulation protocols.

Alternating gonadotropins regimens in sequential treatments are indicated because of variable immunoglobulin affinities to different exogenous gonadotropins (Maurer et al., 1968; Swanson et al., 1995).

Ocelots and tigrinas treated four to six times, at 4-month intervals, with alternating exogenous gonadotropin regimens (eCG/hCG and pFSH/pLH) did not show a reduction in ovarian response (total follicles and Corpora Lutea), oocyte maturation or exogenous gonadotropins antibodies production over time (Paz et al., 2005, 2006). The findings suggest that, these endangered cat species may be managed intensively with the use of alternating exogenous gonadotropin regimens in assisted reproduction procedures without compromising ovarian responsiveness to these hormones.

Specie	Procedure	Treatment 1		Treatment 2	
		ECG (UI)	hCG (UI)	pFSH (UI)	pLH (UI)
Ocelot ( <i>Leopardus pardalis</i> )	AI <sup>6</sup>	400 <sup>6</sup>	200 <sup>6</sup>	-	-
	IVF <sup>4,5</sup>	500 <sup>4,5</sup>	225 <sup>4,5</sup>	50 <sup>4,5</sup>	20 <sup>4,5</sup>
Tigrinus ( <i>Leopardus tigrinus</i> )	AI <sup>4,5</sup>	75 <sup>4,5</sup>	100 <sup>4,5</sup>	30 <sup>4,5</sup>	10 <sup>4,5</sup>
	IVF <sup>6</sup>	200 <sup>6</sup>	150 <sup>6</sup>	-	-
Gato mourisco ( <i>H. yagouarundi</i> )	AI <sup>7</sup>	100 <sup>7</sup>	75 <sup>7</sup>	-	-
	IVF <sup>7</sup>	200 <sup>7</sup>	150 <sup>7</sup>	-	-
Puma ( <i>Puma concolor</i> )	AI <sup>1</sup>	200 <sup>1</sup>	100 <sup>1</sup>	-	-
	IVF	-	-	-	-
Jaguar ( <i>Panthera onca</i> )	AI <sup>2</sup>	200 <sup>2</sup>	150 <sup>2</sup>	-	-
	IVF <sup>3</sup>	-	-	50 <sup>3</sup>	25 <sup>3</sup>

Barone et al., 1994<sup>1</sup>; Jimenez et al., 1999<sup>2</sup>; Morato et al., 2000<sup>3</sup>; Paz et al., 2005<sup>4</sup>; Paz et al., 2006<sup>5</sup>; Swanson et al., 1996a<sup>6</sup>; Swanson (Personal Communication)<sup>7</sup>.

Table 3. Ovarian stimulation with exogenous gonadotropins used in wildlife cats reproduction (AI= Artificial Insemination and IVF= *In vitro* fertilization).

The exogenous gonadotropins dosage used for ovarian stimulation is another important factor to the fertilization rate and subsequent embryonic development (Donoghue et al., 1993). Species with similar size and weight may require varying dosages, possibly because

they have different sensitivities to exogenous gonadotropins (Roth et al., 1997; Swanson et al., 1996b). The nutritional status of the animal also influences the fertilization success rate. Swanson et al. (2002a), studying ocelots and tigrinas in Brazil, observed better quality of oocytes and increase fertilization rates after supplementing the diet with vitamins and minerals.

## 7. Artificial insemination and oocytes collection

The rate of artificial insemination success in carnivores is influenced by the localization of the semen deposition. Non-surgical methods of semen deposition in the vagina has shown inferior results compared with the surgical method, with semen deposition directly into the uterus. This can be explained by the chemical restraint need in wild animals, with the anesthesia compromising the sperm transportation in non-surgically insemination (Howard, 1993).

The artificial insemination success with semen deposition in the uterine horn is described in several species of wild cats such as puma (*Puma concolor*) (Moore et al., 1981); leopard (*Panthera pardus saxicolor*) (Dresser et al., 1982); cheetah (*Acinonyx jubatus*) (Howard, 1992); tiger (*Panthera tigris altaica*) (Donoghue et al., 1993); ocelot (*Leopardus pardalis*) (Swanson, 1996a) and tigrina (*Leopardus tigrinus*) (Moraes et al., 1997).

Artificial insemination using video-laparoscopy technique has been developed for the semen deposition directly into the uterine horn, close to the oviduct where fertilization occurs, in addition to being a less invasive method. In this procedure, the ovaries and uterine horns can be accessed and evaluated for thickness, consistency and color in all species. In cats, the ovaries are easily observed, facilitating the counting and characterization of pre-ovulatory follicles (brighter small elevated areas) and post-ovulatory corpus luteum (yellow-red area).

According to ovarian stimulation protocols, the animals should be inseminated within 24 to 48 hours after hCG or pLH administration, or after the ovulation process. Inhalatory anesthesia is necessary to perform this procedure (Figure 2).



Fig. 2. Anesthesia with isoflurane gas mask (left) and intubation (right). Pictures: Regina Paz.

The anesthetized cats should be secured in dorsal recumbency with the use of leg ties on a tilting surgical table, and the abdominal region of each female should be clipped and prepped

with alternating applications of Betadine scrub and alcohol. A pneumoperitoneum should be created by means of CO<sub>2</sub> gas introduced through a *Verres* needle inserted transcutaneously into the central abdominal cavity. A 7-mm-diameter laparoscope should be inserted through a 1cm skin incision slightly cranial to the umbilicus. The ovaries could be manipulated with the *Verres* needle probe, and each ovary should be closely examined to determine the number of mature follicles ( $\geq 2$  mm diameter), recently-formed corpora lutea, and corpora albicans.

To stabilize the uterine horn, where the cannula will be introduced to deposit the semen, grasping forceps is inserted laterally, 4 to 5 cm of the umbilicus. This procedure maintains the uterus close to the abdominal wall. The horn to be inseminated is the ovary that shows the corpus luteum after ovulation. The procedure should be performed in both uterine horns if both ovaries present the corpus luteum.

For the semen deposition, the uterine horn is cannulated using a 20G sterile needle catheter inserted through the abdominal cavity, near the uterine lumen. As soon as the needle pierces the uterine horn, it is removed, keeping the catheter in place. Inside the catheter, a sterile polypropylene tube must be inserted, which will be connected to a syringe containing the semen. (Figure 3).

The intrauterine artificial insemination by laparoscopy is less invasive because the semen deposition occurs directly in the uterine horn without laparotomy. This methodology resulted in a 46.2% increase in cheetah's pregnancy rates (Howard, 1992).

Similarly, Donoghue et al. (1993) reported the first birth of a tiger cub (*Panthera tigris altaica*) in Siberian Tiger Species Survival Plan (SSP Program) after intrauterine insemination by video-laparoscopy in females stimulated with eCG and hCG. This result demonstrates the importance in using assisted reproduction methods in the production of genetically viable population with recommended breeding by a management program.

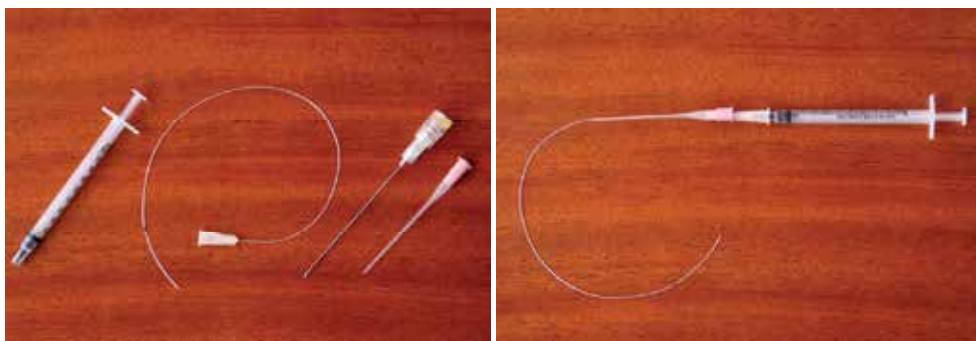

Fig. 3. Intrauterine insemination set: 1mL syringe, polypropylene tube and 22G needle (left). Connected set (right). Pictures: Regina Paz.

The procedures for oocyte retrieval in *in vitro* fertilization are performed using the laparoscopy technique. The ovaries' visualization and the oocyte retrieval in carnivores are species-specific. Cats' ovaries are easily accessed and the follicles easily aspirated.

General anesthesia is needed to perform this procedure; isoflurane inhalation anesthesia is generally used. After anesthetized, the animals are placed in the supine position (45 degrees) and pneumoperitoneum is created with the *Verres* needle, which can be coupled to a CO<sub>2</sub> gas automatic insufflator or a manual pump.



The endoscope is placed near the umbilicus for the evaluation of ovaries and observation of the follicles. Only mature follicles, larger than 2 mm, should be aspirated. The *Verres* needle is used for the follicles' size determination and for the maintenance of the ovary in an adequate position, near to the abdominal wall.

The mature follicles are aspirated with a 22G needle attached to polypropylene tubing connected to a sterile collection tube (15mL) containing M199 culture medium and heparin, which is attached to a vacuum aspiration pump (Figure 4). After the collection, the oocytes are placed in petri dishes with culture medium and observed by stereomicroscopy at 400 X magnification for their classification.

The oocytes from carnivores are dark and contain lipidic drops. The maturation status is characterized in I, II and III according morphological aspects. Oocytes I are of excellent quality, characterized by a uniformly dark cytoplasm, nucleus with a distinct corona radiata, and an expansive cumulus cell mass. Oocytes II are of regular quality, characterized by a non-uniformly cytoplasm, nucleus with an indistinct corona radiata, and a non-expansive cumulus cell mass. Oocytes III are degenerated and characterized by an abnormal cytoplasm, nucleus without corona radiata or cumulus cell mass (Goodrowe et al., 1988; Johnston et al., 1989).



Fig. 4. Follicular aspiration using video-laparoscopy and *Verres* needle in ocelot (left). Aspiration follicular system (right). Pictures: Regina Paz.

## 8. *In vitro* fertilização and embryo transfer

The *in vitro* fertilization technique has been applied in wild animals after follicular aspiration using laparoscopy technique, oocyte retrieval post-mortem, or after ovariectomy. According Swanson (1998), oocytes collected from ovaries can be refrigerated at 5°C for 24 hours without maturation and changes in the fertilization potential.

Oocytes recovery from refrigerated ovaries can be achieved using the follicular aspiration technique with a syringe and needle, or through ovary laceration and oocyte harvest using stereomicroscopy. The second technique is used in small animals, which present ovaries with small diameters because the follicle aspiration would be difficult. The M199 culture medium is used for follicular aspiration and ovaries laceration.

However, laparoscopic follicular aspiration is the most used oocyte retrieval technique for IVF, which should be preceded by hormonal treatment. According Howard (1999), the

treatment with exogenous gonadotropins and laparoscopy are the basic requirements for ovarian stimulation and oocyte retrieval for IVF procedures.

The immature oocytes collected ( $\cong 60\%$ ) in cats become mature in 24-32 hours in culture media. These about 70% are fertilized, however, only a small percentage, from 20 to 30% develops in blastocysts (Johnston et al., 1989).

Donoghue et al. (1990) reported the birth of the first wild cat from IVF after an embryo transfer. Tiger cubs (*Panthera tigris*) were produced *in vitro* using excellent quality embryos, containing two to four cells, and surgically transferred to the oviducts of two females. Pregnancy was successful in one of these females and three kittens were born after 107 days.

The first embryos produced by IVF in Brazil were jaguar (*Panthera onca*) embryos. The ovarian stimulation with pFSH/LH produced  $\cong 25$  follicles/female ( $> 80\%$ ), however, despite the recovery of high quality oocytes, the fertilization percentages were low ( $> 25\%$ ) (Morato et al., 2000).

In a Project involving the São Paulo University/Brazil (USP), the Mata Ciliar Association/Brazil (AMC) and the Cincinnati Zoo/USA (CREW), 128 ocelot (*Leopardus pardalis*) and tigrina (*Leopardus tigrinus*) embryos were produced. The animals were treated with eCG/hCG and produced  $\cong 10$  follicles/female. Follicles were aspirated by laparoscopy and 7-9 of excellent quality oocytes/female were recovered. Of these, 60% were fertilized *in vitro*, resulting in 76 ocelot and 52 tigrina embryos (Swanson & Brown, 2004). Two ocelots became pregnant with normal pregnancy development and birth, one from the Cincinnati Zoo/USA and another from the Sao Bernardo do Campo Zoo/Brazil. However, only the offspring born to the American female survived after birth (Swanson, 2002b).

Among all the Neotropical cats, the ocelot is the only species that produced offspring after the transfer of frozen embryos (Swanson, 2001, 2002b). These births were the result of a cooperative effort between Brazil and the USA for the development of adequate management programs for this species in captivity, and for the establishment of genetically viable populations between the Brazilian and American populations.

Based on the percentage of successful embryonic cleavage after thawing domestic cat embryos, which is less than 70% (Pope, 2000), the difficulties to develop feline embryos used post-freezing is recognized. The difficulties may be related to inappropriate timing for the embryo implantation or fetal survival (Swanson & Brown, 2004) and not only related to the quality of the embryos. Thus, it is necessary to detect the female natural receptor estrus in order to perform the transfer of thawed embryos. This determination is achieved through measurement of fecal steroid levels according to the enzyme-immunoassay (EIA) technique for the fecal estrogens metabolites.

After the determination of the natural estrus, the ovulation should be induced with GnRH (Gonadotropin Releasing Hormone) and the embryos should be transferred by video-laparoscopy directly in the ostium of the oviduct.

## 9. Transmission of reproductive diseases

The methods used for assisted reproduction in wild animals should be free of contamination or diseases, therefore, some measures must be taken to avoid compromising the procedures. The semen centrifugation and seminal plasma removal are essential for artificial insemination with fresh or frozen semen and *in vitro* fertilization procedures.

The methods for processing semen without centrifugation and removal of the seminal plasma were responsible for the development of pyometra in 40% of inseminated domestic cats, regardless of the semen being diluted in culture medium containing antibiotics penicillin and streptomycin (Howard, 1993). It is believed that the donors might carry bacteria in their normal flora, eg *E. coli*, which would cause infection in the females.

In a study conducted by Paz et al. (1999), aiming at determining preputial microbiota in nine adult male jaguars (*Panthera onca*), the most frequently observed microorganism were *Staphylococcus sp* (40%), followed by *Streptococcus sp* (30%), *Escherichia coli* (20%) and *Corynebacterium sp* (10%).

The preputial microbiota in the genus *Leopardus* was assessed by Guido et al. (2000), and the results were *Escherichia coli* (40%), *Proteus rettgeri* (40%) and *Yersinia pseudotuberculosis* (20%) in tigrina (*Leopardus tigrinus*) (n = 5), *Staphylococcus sp* (42.9%), *Escherichia coli* (28.5%), *Streptococcus sp* (14.3%), *Staphylococcus sp* + *Streptococcus sp* (14.3%) in ocelots (*Leopardus pardalis*) (n = 6) and only *Staphylococcus sp* in margay (*Leopardus wieddi*) (n = 1).

The feline immunodeficiency virus is present in the semen of domestic cats and can be transmitted to females by AI (Jordan et al., 1995, 1996). This aspect should be taken into consideration during assisted reproduction procedures performed in wild cats.

In addition, a reproductive evaluation and clinical examination should be performed in wild cats before the animal inclusion in the management programs using assisted reproduction.

## 10. References

- Bartels, P.; Lubbe, K.; Killian, L.; Friedmann, Y.; Van Dyk, G. & Mortimer, D. (2000). In vitro maturation and fertilization of lion (*Panthera onca*) oocytes using frozen-thawed epididymal spermatozoa recovered by cauda epididymectomy of an immobilized lion. *Theriogenology*, Vol. 53, pp. 325.
- Barone, M. A.; Wildt, D. E.; Byers, A. P.; Roelke, M. E.; Glass, C. M. & Howard, J. G. (1994). Gonadotrophin dose and timing of anaesthesia for laparoscopic artificial insemination in the puma (*Felis concolor*). *Journal of Reproduction and Fertility*, Vol.101, pp. 103-108.
- Bonney, R. C.; Moore, H. D. M. & Jones, D. M. (1981). Plasma concentrations of oestradiol-17 $\beta$  and progesterone, and laparoscopic observations of the ovary in the puma (*Felis concolor*) during oestrus, pseudopregnancy and pregnancy. *Journal of Reproduction and Fertility*, Vol.63, pp. 523-532.
- Briz, M. D.; Bonet, S.; Pinart, B.; Egozcue, J. & Campos, R. (1995). Comparative study of boar sperm coming from the caput, corpus, and cauda regions of the epididymis. *Journal of Andrology*, Vol. 16, pp. 175-188.
- Brown, J. L.; Wasser, S. K.; Wildt, D.E. & Graham, L. H. (1994). Comparative aspects of steroid hormone metabolism and ovarian activity in felids, measured noninvasively in feces. *Biology of Reproduction*, Vol.51, pp. 766-86.
- Brown, J. L.; Terio, K. A. & Graham, L. H. (1996). Fecal androgen metabolite analysis for non invasive monitoring of testicular steroidogenic activity in felids. *Zoo Biology*, Vol.15, pp. 425-434.
- Byers, A. P.; Hunter, A. G.; Seal, E. S.; Graham, E.F. & Tilson, R.L. (1990). Effect of season on seminal traits and serum hormone concentration in male Siberian tiger (*Panthera tigris*). *Journal of Reproduction and Fertility*, Vol. 90, pp. 119-125.

- Comizzoli, P.; Mermillod, P. & Mauget, R. (2000). Reproductive biotechnologies for endangered mammalian species. *Reproduction Nutrition Development*, Vol.40, pp. 493-504.
- Crichton, E. G.; Armstrong, D. L.; Vajta, G.; Pope, C. E. & Loskutoff, N. M. (2000). Development competence in vitro of embryo produce from siberian tigers (*Panthera tigris altaica*) cryopreserved by controlled rate freezing versus vitrification. *Theriogenology*, Vol.53, No.1, pp.328. Abstract.
- Crichton, E. G.; Bedows, E.; Miller-Lindholm, A. K.; Baldwin, D. M.; Armstrong, D. L.; Graham, L. H.; Ford, J. J.; Gjorret, J. O.; Hyttel, P.; Pope, C. E.; Vajta, G. & Loskutoff, N. M. (2003). Efficacy of porcine gonadotropins for repeated stimulation of ovarian activity for oocyte retrieval and in vitro embryo production and cryopreservation in siberian tigers (*Panthera tigris altaica*). *Biology of Reproduction*, Vol.68, pp. 105-113.
- Donoghue, A. M.; Johnston, L. A.; Seal, U. S.; Armstrong, D. L.; Tilson, R. L.; Wolf, P.; Petrini, L. G.; Simmons, T.; Groos, T. & Wildt, D. E. (1990). In vitro fertilization and embryo development in vitro and in vivo in the tiger (*Panthera tigris*). *Biology of Reproduction*, Vol.43, pp. 733-44.
- Donoghue, A. M.; Johnston, L. A.; Armstrong, D. L.; Simmons, L. G. & Wildt, D. E. (1993). Birth of a siberian tiger cub (*Panthera tigris altaica*) following laparoscopic intrauterine artificial insemination. *Journal of Zoo and Wildlife Medicine*, Vol.24, No.2, pp. 185-89.
- Dooley, M. P.; Pineda, M. H; Hopper, J. G. & Hsu, W. H. (1991). Retrograde flow of spermatozoa into the urinary bladder of cats during eletroejaculation, collection of semen with an artificial vagina, and mating. *American Journal Veterinary Research*, Vol.52, No.5, pp. 687-91.
- Dresser, B. L.; Kramer, L.; Reece, B. & Russel, P. T. (1982). Induction of ovulation and successful artificial insemination in a Persian Leopard (*Panthera pardus saxicolor*). *Zoo Biology*, Vol.1, pp. 55-57.
- Dresser, B. L.; Sehlhorst, C. S.; Keller, G.; Kramer, L. W. & Reece, R. W. (1986). Artificial insemination and embryo transfer in the felidae. *Proceedings of International Symposium for World Conservation Strategies for Tigers*, pp. 4-18, Cincinnati, Ohio, USA.
- Dresser, B. L.; Gelwicks, E. J.; Wachs, K. B. & Keller, G. L. (1988). First successful transfer of cryopreserved feline (*Felis catus*) embryos resulting in live offspring. *The Journal of Experimental Zoology*, Vol.246, pp. 180-186.
- Ewer, R. F. (1975). The evolution of mating system in the felidae. In: *The world's cats: biology, behavior and management of reproduction*. Eaton, R. L. pp. 11-20, London: Unimark Publishing.
- Feldman, E. C. & Nelson, R. W. (1996). *Canine and Feline Endocrinology and Reproduction*. pp. 529-46, 2 ed, Philadelphia: W.B. Saunders.
- Goodrowe, K. L.; Hay, M. (1993). Characteristics and zona binding ability of fresh and cooled domestic cat epididymal spermatozoa. *Theriogenology*, Vol. 40, pp. 967-75.
- Goodrowe, K. L.; Wall, R. J.; O'Brien, S. J.; Schmidt, P. M. & Wildt, D. E. (1988). Developmental competence of domestic cat follicular oocytes after fertilization in vitro. *Biology of Reproduction*, Vol.39, pp. 355-372.
- Guido, M. C.; Paz, R. C. R.; Costa, E. O.; Zuge, R. M.; Benites, N. R.; Barnabe, V. H. & Barnabe, R. C. , (2000). Microbiota prepucial e vaginal de felinos neotropicais mantidos em cativeiro. *Proceedings of Combravet XVII Congresso Brasileiro de Medicina Veterinária*, pp.03, Águas de Lindóia, São Paulo, Brasil, 2000.

- Hamner, C. E.; Jennings, L. L. & Sojka, N. J. (1970). Cat (*Felis catus* L.) spermatozoa require capacitation. *Journal Reproduction and Fertility*, Vol.23, pp. 477-480.
- Hay, M. A.; Goodrowe, K. L. (1993). Comparative cryopreservation and capacitation of spermatozoa from epididymides and vasa deferentia of the domestic cat. *Journal Reproduction and Fertility Supplement*, Vol. 47, p. 297-30.
- Howard, J.; Donoghue, A. M.; Barone, M. A.; Goodrowe, K. L.; Blumer, E. S.; Snodgrass, B. S.; Sarnes, D.; Michael, T.; Bush, M. & Wildt, D. E. (1992). Successful induction of ovarian activity and laparoscopic intrauterine artificial insemination in the cheetah (*Acinonyx jubatus*). *Journal of Zoo and Wildlife Medicine*, Vol.23, No.3, pp. 288-300a.
- Howard, J. (1992). Embryogenesis in conservation biology or how to make an endangered species embryo. *Theriogenology*, Vol.37, No.1 b.
- Howard, J. G. (1993). Semen collection and analysis in carnivores. In: *Zoo & Wild Animal Medicine Current Therapy*, Fowler, M. E, pp.390-399, 3 ed. Philadelphia: W.B. Saunders.
- Howard J. G. (1999). Assisted reproductive techniques in nondomestic carnivores. In: *Zoo & Wild Animal Medicine*, Fowler, M.E. & Miller, R.E.. pp.449-457, 4 ed., Philadelphia: W.B. Saunders.
- IUDZG/CBSG. (1993). *The word zoo conservation strategy: the role of the zoos and aquaria of the world in global conservation*. Chicago: Zoological Society, 76 p.
- Jewgenow, K.; Blottner, S.; Lengwinat, T. & Meyer, H.H.D. (1997). New methods for gametes rescue from gonads of nondomestic felids. *Journal of Reproduction and Fertility Supplement*, Vol. 51, pp. 33-39.
- Jimenez, T. G.; Zuge, R.; Paz, R. C. R.; López, J. E. & Crudeli, G. A. (1999). Sincronización de celo e inseminación artificial por video laparoscopia en yagueté (*Panthera onca*) en cautiverio. *Comunicaciones Científicas y Tecnológicas*, Vol.4, pp. 67-70.
- Johnston, L.A.; O'Brien, S. J. & Wildt, D. E. (1989). In vitro maturation and fertilization of domestic cat follicular oocytes. *Gamete Research*, Vol. 24, No.3, pp. 343-56.
- Johnston, L. A.; Armstrong, D. L. & Brown, J. L. (1994). Seasonal effects on seminal and endocrine traits in the captive snow leopard (*Panthera uncia*). *Journal of Reproduction and Fertility*, Vol. 102, pp. 229-236.
- Johnston, S. D.; Root, M. V. & Olson, P. N. S. (1996). Ovarian and testicular functions in the domestic cat: clinical management of spontaneous reproductive disease. *Animal Reproduction Science*, Vol.42, pp. 261-274.
- Jordan, H. L.; Howard, J. G. & Tompkins, W. A. (1995). Detection of feline immunodeficiency virus in semen from seropositive domestic cats (*Felis catus*). *Journal Virology*, Vol.69, pp. 7328-7333.
- Jordan, H. L.; Howard, J. G & Sellon, R. K. (1996). Transmission of feline immunodeficiency virus in domestic cats via artificial insemination. *Journal Virology*, Vol.70, pp. 8224-8228.
- Lasley, B. L.; Loskutoff, N. M. & Anderson, G. B. (1994). The limitation of conventional breeding programs and the need and promise of assisted reproduction in non-domestic species. *Theriogenology*, Vol.41, pp. 119-132.
- Maksudov GYu, Shishova NV, & Katkov II. 2009. In the Cycle of Life: Cryopreservation of Post-Mortem Sperm as a Valuable Source in Restoration of Rare and Endangered Species. In: *Endangered Species: New Research*. Eds.: A.M. Columbus and L. Kuznetsov. NOVA Science Publishers, Hauppauge NY, Ch. 8, pp 189-240.
- Maurer, R. R.; Hunt, W. L. & Foote, R. H. (1968). Repeated superovulation following administration of exogenous gonadotrophins in dutch-belted rabbits. *Journal Reproduction and Fertility*, Vol.15, pp.93-102.

- Mellen, J.D. 1989. *Reproductive behavior of small captive exotic cats (Felis sp)*. (Doctoral thesis) University of California. Davis/CA.
- Moore, H. D. M.; Bonney, R. C. & Jones, D. M. (1981). Successful induced ovulation and artificial insemination in the puma (*Felis concolor*). *Veterinary Record*, Vol.108, pp.282-83.
- Moraes, W.; Morais, R.; Moreira, N.; Lacerda, O.; Gomes, M. L. F.; Mucciolo, R. G. & Swanson, W. F. (1997). Successful artificial insemination after exogenous gonadotropin treatment in the ocelot (*Leopardus pardalis*) and tigrina (*Leopardus tigrina*). *Proceedings of American Association of Zoo Veterinarians Congress*, p. 334-335.
- Morais, R. N.; Moreira, W.; Mucciolo, R. G.; Lacerda, O.; Gomes, M. L. F.; Swanson, W. F.; Graham, L. H. & Brown, J. L. (1996). Testicular and ovarian function in south american small felids assessed by fecal steroids. *Proceedings of American Association of Zoo Veterinarians Congress*, pp. 561-565.
- Morais, R. N. (2001). Reproduction in small felid males. In: *Biology, Medicine and Surgery of South American Wild Animals*, Fowler, M. E. & Cubas, Z. S. (ed). 1 ed. Ames: Iowa State University Press. pp.312-316.
- Morato, R. G.; Crichton, E. G.; Paz, R. C. R.; Zúge, R. M.; Moura, C. A.; Nunes, A. V. L.; Teixeira, R. H.; Porto-Filho, L.; Guimarães, M. A. B. V.; Correa, S. H. R.; Barnabe, R. C.; Armstrong, D. L. & Loskutoff, N. M. (2000). Ovarian stimulation and successful in vitro fertilization in the jaguar (*Panthera onca*). *Theriogenology*, Vol.53, No.1, pp.339. Abstract.
- Morato, R. G. & Paz, R. C. R. (2001). *Reproduction in jaguars*. In: *Biology, Medicine and Surgery of South American Wild Animals*, Fowler, M. E. & Cubas, Z. S. (ed). 1 ed. Ames: Iowa State University Press. pp.308-312.
- Moreira, N.; Monteiro-Filho, E. L. A.; Moraes, W.; Swanson, W. F.; Graham, L. H.; Pasqual, O. L.; Gomes, K. L. F.; Morais, R. N.; Wildt, D. E. & Brown, J. L. (2001). Reproductive steroid hormones and ovarian activity in felids of the leopardus genus. *Zoo Biology*, Vol.20, pp.103-116.
- Oliveira, T. G. (1994). *Neotropical Cats Ecology and Conservation*. São Luis: EDUFMA, 220 p.
- Oliveira, T. G. & CASSARO, K. , (1997). *Guia de Identificação dos Felinos Brasileiros*. São Paulo: Fundação Parque Zoológico de São Paulo, 60p.
- Paz, R. C. R.; Guido, M. C.; Costa, E. O.; Zúge, R. M.; Morato, R. G.; Guimarães, M. A. B. V.; Nunes, A. L. V.; Felipe, P. A. N.; Jimenez, G. T.; Crudeli, G. A.; Barnabe, V. H. & Barnabe, R. C. (1999). Microbiota Prepuccial de onças pintadas (*Panthera onca*) mantidas em cativeiro. *Proceedings of Congresso Brasileiro para Conservação de Felinos Neotropicais*, Jundiaí, São Paulo, Brasil.
- Paz, R. C. R.; Zúge, R. M.; Morato, R. G.; Barnabe, V. H.; Barnabe, R. C. & Felipe, P. A. N. (2000). Capacidade de Penetração de sêmen congelado de onça pintada (*Panthera onca*) em oócitos heterólogos. *Brazilian Journal of Veterinary Research and Animal Science*, Vol.37, No.6, pp. 462-466.
- Paz, R. C. R.; Swanson, W. F.; Dias, E. A.; Adania, C. H.; Barnabe, V. H. & Barnabe, R. C. (2005). Ovarian and immunological responses to alternating exogenous gonadotropin regimens in the ocelots (*Leopardus pardalis*) and tigrina (*Leopardus tigrinus*). *Zoo Biology*, Vol.24, pp.247-260.
- Paz, R. C. R.; Dias, E. A.; Adania, C. H.; Barnabe, V. H. & Barnabe, R. C. (2006). Ovarian response to repeated administration of alternating exogenous gonadotropin regimens in the ocelot (*Leopardus pardalis*) and tigrinus (*Leopardus tigrinus*). *Theriogenology*, Vol. 66, pp. 1787-1789.

- Pope, C. E.; Gelwicks, E. J.; Wachs, K. B.; Keller, G. L.; Maruska, E. J. & Dresser, P. L. (1989). Successful interspecies transfer of embryos from the Indian desert cat (*Felis silvestris ornata*) to the domestic cat (*Felis catus*) following in vitro fertilization. *Biology of Reproduction*, Vol.40, pp. 61. Supplementum 40.
- Pope, C. E. (2000). Embryo technology in conservation efforts for endangered felids. *Theriogenology*, Vol.53, pp. 163-174.
- Rodrigues da Paz, R. C.; Morato, R. G.; Carciofi, A. C.; Guimarães, M.A.B.V.; Pessuti, C.; Ferraz, E. S.; Ferreira, F. & Barnabe, R.C. (2006). Influence of nutrition on the quality of semen in Jaguars (*Panthera onca*) in Brazilian zoos. *International Zoo Yearbook*, Vol.40, p 351-359.
- Roth, T. L.; Wolfe, B. A.; Long, J. A.; Howard, J. & Wildt, D. E. (1997). Effects of equine chorionic gonadotropin, human chorionic gonadotropin, and laparoscopic artificial insemination on embryo, endocrine, and luteal characteristics in the domestic cat. *Biology of Reproduction*, Vol.57, pp.165-71.
- Seal, U. S.; Plotka, E. D.; Smith, J. D.; Wright, F. H.; Reindl, N. J.; Taylor, R. S. & Seal, M. F. (1985). Immunoreactive luteinizing hormone estradiol, progesterone, testosterone, and androstenedione levels during the breeding season and anestrus in siberian tigers. *Biology of Reproduction*, Vol. 32, pp. 361-368.
- Schmidt, A. M.; Nadal, L. A.; Schmith, M. J. & Beamer, N. B. (1979). Serum concentrations of oestradiol and progesterone during the normal oestrus cycle and early pregnancy in the lion (*Panthera leo*). *Journal of Reproduction and Fertility*, Vol. 57, pp. 267-272.
- Schmidt, A. M.; Hess, D. L.; Schmith, M. J.; Smith, R. C. & Lewis, C. R. (1988). Serum concentration of oestradiol and progesterone, and sexual behavior during the normal oestrus cycle in the leopard (*Panthera pardus*). *Journal Reproduction and Fertility*, Vol. 82, pp. 43-49.
- Schmidt, A. M.; Hess, D. L.; Schmith, M. J. & Lewis, C. R. (1993). Serum concentration of oestradiol and progesterone and frequency of sexual behavior during the normal oestrous cycle in the snow leopard (*Panthera uncia*). *Journal Reproduction and Fertility*, Vol. 98, pp. 91-95.
- Seal, U. S.; Plotka, E. D.; Smith, J. D.; Wright, F. H.; Reindl, N. J.; Taylor, R. S. & Seal, M. F. (1985). Immunoreactive luteinizing hormone estradiol, progesterone, testosterone, and androstenedione levels during the breeding season and anestrus in siberian tigers. *Biology of Reproduction*, Vol.32, pp.361-368.
- Shille, V. M.; Lundström, K. E. & Stabenfeldt, G. H. (1979). Follicular function in the domestic cat as determined by estradiol-17 $\beta$  concentration in plasma: relation to estrous behavior and cornification of exfoliated vaginal epithelium. *Biology of Reproduction*, Vol.21, pp. 953-963.
- Silva, J. C.; Leitão, R. M.; Lapão, N. E.; Cunha, M. B.; Cunha, T. P.; Silva, J. P. & Paisana, F. C. (2000). Birth of siberian tiger (*Panthera tigris altaica*) cubs after transvaginal artificial insemination. *Journal of Zoo and Wildlife Medicine*, Vol.34, pp. 566-569.
- Spindler, R. E.; Wildt, D. E. (1999). Circannual variations in intraovarian oocyte but not epididymal sperm quality in the domestic cat. *Biology of Reproduction*, Vol. 61, pp. 188-194.
- Swanson, W. F.; Brown, J. L.; Wildt, D. E. (1996). Influence of season on reproductive traits of the male Pallas' cat (*Felis Manul*) and implications for captive management. *Journal of Zoo and Wildlife Medicine*, Vol. 27, pp. 234-240.
- Swanson, W. F.; Horohov, D. W. & Godke, R. A. (1995). Production of exogenous gonadotrophin-neutralizing immunoglobulins in cats after repeated eCG-hCG

- treatment and relevance for assisted reproduction in felids. *Journal of Reproduction and Fertility*, Vol.105, pp. 35-41.
- Swanson, W. F.; Howard, J. G.; Roth, T. L.; Brown, J. L.; Alvarado, T.; Burton, M.; Starnes, D. & Wildt, D. E. (1996). Responsiveness of ovaries to exogenous gonadotrophins and laparoscopic artificial insemination with frozen-thawed spermatozoa in ocelots (*Felis pardalis*). *Journal of Reproduction and Fertility*, Vol.106, pp. 87-94 a.
- Swanson, W. F.; Roth, T. L.; Graham, K.; Horohov, D. W. & Godke, R. A. (1996). Kinetics of the humoral immune response to multiple treatments with exogenous gonadotropins and relation to ovarian responsiveness in domestic cats. *American Journal Veterinary Research*, Vol.57, No.3, pp. 302-307 b.
- Swanson, W. F. (1998). Reproduction in domestic cats: model for endangered nondomestic cat species. In: *Curso de extensão - Felinos selvagens: biotécnicas reprodutivas e conservação*, Morais, R. N. & Gomes, M. L. F. Curitiba: Departamento de Fisiologia da Universidade Federal do Paraná, 100 p.
- Swanson, W. F. (2001). Reproductive biotechnology and conservation of the forgotten felids – the small cats. *Proceedings of 1<sup>st</sup> International Symposium on Assisted Reproductive Technologies: Conservation & Genetic Management Wildlife*, Omaha, Nebraska, USA, pp. 100-120.
- Swanson, W. F.; Paz, R. C. R.; Morais, R. N.; Gomes, M. L. G.; Moraes, W. & Adania, C. H. (2002). Influence of species and diet on efficiency of in vitro fertilization in two endangered Brazilian felids – The ocelot (*Leopardus pardalis*) and tigrina (*Leopardus tigrinus*). *Theriogenology*, Vol.57, No.1, pp. 593. Abstract.a
- Swanson, W. F. (2002). The role of science and reproductive biotechnology in establishing and managing the Brazilian ocelot population in U.S. and Brazilian Zoos. *Proceedings of Annual Conference of the American Zoo & Aquarium Association*, Fort Worth, Texas, USA. pp.75-78.b
- Swanson, W. F. & Brown, J. L. (2004). International training programs in reproductive sciences for conservation of Latin American felids. *Animal Reproduction Science*, Vol.82-83, pp. 21-34.
- Tebet, J. M. (1999). *Aspectos clínicos e fisiológicos do ciclo estral da jaguatirica (Leopardus pardalis, L.1758)*. (Dissertação Mestrado em Reprodução Animal) - Faculdade de Medicina Veterinária e Zootecnia, Universidade Estadual Paulista “Júlio de Mesquita Filho”, Botucatu, São Paulo. pp. 102.
- Tebet, J. M.; Martins, M. I. M.; Chirinea, V. H.; Souza, F. F.; Campagnol, D.; Lopes, M. D. (2006). Cryopreservation effects on domestic cat epididymal versus electroejaculated spermatozoa. *Theriogenology*, Vol. 66, pp. 1629-1632.
- Tsuitsui, T. & Stabenfeldt, G. H. (1996). Biology of ovarian cycles, pregnancy and pseudopregnancy in the domestic cat. *Journal of Reproduction and Fertility*, pp. 29-35. Supplementum 47.
- Verhage, H. G.; Beamer, N. B. & Brenner, R. M. (1976). Plasma levels of estradiol and progesterone in the cat during polyestrus, pregnancy and pseudopregnancy. *Biology of Reproduction*, Vol.14, pp. 579-585.
- Wildt, D. E.; Platz, C. C.; Chakraborty, P. K. & Seager, S. W. J. (1979). Oestrus and ovarian activity in a female jaguar (*Panthera onca*). *Journal of Reproduction and Fertility*, Vol.56, pp. 555-58.
- Wildt, D. E.; Platz, C. G.; Seager, S. W. J. & Bush, M. (1981). Induction of ovarian activity in the cheetah (*Acinonyx jubatus*). *Biology of Reproduction*, Vol.24, pp. 217-222.



## **Part 6**

# **Cryopreservation of Aquatic Species**



# Effect of Cryopreservation on Bio-Chemical Parameters, DNA Integrity, Protein Profile and Phosphorylation State of Proteins of Seawater Fish Spermatozoa

Loredana Zilli and Sebastiano Vilella

*Laboratory of Comparative Physiology, Department of Biological and Environmental Sciences and Technologies,  
University of Salento, Via Provinciale Lecce-Monteroni, Lecce  
Italy*

## 1. Introduction

Fish sperm cryopreservation is considered as a valuable technique for artificial reproduction and genetic improvement (Chao & Liao, 2001; Kopeika et al., 2007; Rana, 1995; Suquet et al., 2000). Semen quality must be monitored when attempts are made to increase the efficiency of artificial fertilization, to cryopreserve only sperm of high quality, and to evaluate frozen-thawed sperm. Cryopreserved sperm usually shows, with respect to fresh sperm, a lower quality, since the freezing-thawing procedure affects DNA and protein integrity (Labbe et al., 2001; Zilli et al., 2003, 2005), membrane lipids (Maldjian et al., 2005; Müller et al., 2008), sperm motility (Linhart et al., 2000; Ritar, 1999; Rodina et al., 2007; Zilli et al., 2005), fertilization ability (Gwo & Arnold, 1992; Rana, 1995), and also larval survival (Suquet et al., 1998). Spermatozoa genome alteration due to cryopreservation may affect only late embryonic development and larval survival (Kopeika et al., 2003a, 2003b, 2004; Suquet et al., 1998), but not the early events in embryonic development, because these are controlled by maternally inherited information (Braude et al., 1988). On the contrary, defects in sperm proteins (degradation and/or change of the phosphorylation state) may compromise sperm motility, fertilization ability, and the early events after fertilization (Cao et al., 2003; Huang et al., 1999; Lessard et al., 2000).

The most common parameters used to evaluate sperm quality are fertilization ability, motility (rate and duration) and cellular (chemical and/or biochemical) parameters. Fertilizing capacity is the most conclusive test of sperm quality but the use of this marker is laborious and requires the availability of eggs (McNiven et al., 1992). Motility is normally evaluated as percentage and duration, but some authors also use velocity, flagellum beat frequency, or other parameters measured by computer-assisted sperm analysis (Ciereszko et al., 1996; Cosson et al., 2000; Rurangwa et al., 2001). Cellular bio markers has been used to evaluate spermatozoa quality of different fish species such as Atlantic salmon (Aas et al., 1991; Hwang & Idler, 1969), rainbow trout (Ciereszko & Dabrowski, 1994; Lahnsteiner et al., 1996a, 1998) and sea bass (Zilli et al., 2004). All these

parameters have been also used to evaluate the effect of cryopreservation on spermatozoa quality.

Here we reviewed data obtained by our group, on the effect of freezing-thawing procedures on sea bass and sea bream sperm. In particular, data concerning the effect of cryopreservation on bio-chemical parameters, DNA integrity, protein profile and phosphorylation state, are reported.

## **2. Effect of freezing-thawing procedure on sea bass spermatozoa bio-chemical parameters. Use of intracellular ATP concentration and seminal plasma $\beta$ -D-glucuronidase activity as quality marker of fresh and frozen-thawed semen**

### **2.1 Effect of cryopreservation on sea bass semen**

The cryopreservation of spermatozoa is known to result in considerable damage to cellular structures such as plasma membrane, nucleus, mitochondria, and flagellum (Conget et al., 1996; Drokin et al., 1998; Lahnsteiner et al., 1992; 1996b; Zhang et al., 2003). Spermatozoa plasma membrane is the cellular structure most susceptible to damage during cryopreservation (Baynes & Scott, 1987). It is well known that the activity of intracellular enzymes, the seminal plasma protein concentrations and the seminal plasma enzyme activities can be used to evaluate spermatozoan plasma membrane integrity (Babiak & Glogowski, 1997; Lahnsteiner et al., 1998; McNiven et al., 1992). Our group has evaluated (Zilli et al., 2004) the effect of cryopreservation on sea bass semen quality by measuring chemical and biochemical parameters (reported in Table 1), before and after sperm cryopreservation. Results obtained demonstrated that, the used cryopreservation protocol did not cause significant injuries to spermatozoan plasma membranes, since the activity of the intracellular enzymes as well as the seminal plasma protein concentrations and  $\beta$ -D-glucuronidase activity were not affected by the freezing-thawing procedure. The absence of injuries at the plasma membrane level was also supported by the observation that eosin uptake was similar in fresh and frozen-thawed spermatozoa (75-80%). Only malate dehydrogenase activity and intracellular ATP concentration resulted significantly higher in cryopreserved than in fresh samples, while the pH of seminal plasma resulted significantly lower after freezing

Since respiration rate, malate dehydrogenase activity, and intracellular ATP concentration did not decrease in frozen/thawed spermatozoa we concluded that spermatozoan mitochondria were intact and active after cryopreservation procedure. The increases in both intracellular ATP concentration and malate dehydrogenase activity following the freezing-thawing procedure has been also reported in *Silurus glanis* (Ogier de Baulnyet al., 1999). The increase of intracellular ATP concentration occurs during early freezing of sperm (from +20°C to -10°C) (Baynes & Scott, 1987) and is most probably attributable to dimethyl sulfoxide, used as cryoprotectant, which interferes with cellular metabolism (McConnell et al., 1999). No data is available concerning the kinetics and structure of mitochondrial malate dehydrogenase in fish. In other vertebrates, mitochondrial malate dehydrogenase shows a complex dependence on the ionic environment, which influences both kinetics and structure (Birktoft et al., 1989; Bleile et al., 1977; Harada & Wolf, 1968;

Ruggia et al., 2001; Wood et al., 1981). The increase of malate dehydrogenase activity after cryopreservation could be a consequence of the oxidative stress that occurs during the freezing phase, as previously suggested (Lahnsteiner et al., 1998), or could be due to the presence of anions that increase the activity of the enzyme by stabilizing the dimeric form (Ruggia et al., 2001).

Parameters	Fresh sperm	Cryopreserved sperm
Respiration rate ( $\mu\text{g O}_2/\text{min} \times \text{ml}$ seminal fluid)	6.71 $\pm$ 0.76a (N=22)	7.09 $\pm$ 1.22a (N=18)
Aspartate aminotransferase (U/mg protein)	0.010 $\pm$ 0.008a (N=62)	0.012 $\pm$ 0.009a (N=45)
Malate dehydrogenase (U/mg protein)	0.054 $\pm$ 0.03a (N=65)	0.079 $\pm$ 0.046b (N=61)
Isocitrate dehydrogenase (U/mg protein)	0.11 $\pm$ 0.05a (N=45)	0.18 $\pm$ 0.10a (N=40)
Intracellular ATP ( $\mu\text{moli}/\text{protein}$ )	1.22 $\pm$ 0.65a (N=72)	1.92 $\pm$ 1.11b (N=66)
Intracellular triglycerides ( $\mu\text{moli}/\text{protein}$ )	0.33 $\pm$ 0.24a (N=48)	0.25 $\pm$ 0.14a (N=38)
Intracellular glycerol ( $\mu\text{moli}/\text{protein}$ )	0.28 $\pm$ 0.18a (N=45)	0.21 $\pm$ 0.15a (N=27)
Seminal plasma osmolality (mOsm/Kg)	352.1 $\pm$ 19.7a (N=22)	354.9 $\pm$ 20.7a (N=18)
Seminal plasma pH	8.21 $\pm$ 0.45a (N=62)	7.65 $\pm$ 0.61b (N=45)
Seminal plasma protein (mg/l)	815.3 $\pm$ 174.5a (N=45)	837.1 $\pm$ 180.0a (N=40)
Seminal plasma triglycerides ( $\mu\text{moli}/\text{l}$ )	226.2 $\pm$ 107.2a (N=72)	181.8 $\pm$ 103.0a (N=66)
Seminal plasma $\beta$ -D-glucuronidase (U/l)	0.0083 $\pm$ 0.0066a (N=48)	0.0093 $\pm$ 0.0049a (N=38)

Table 1. Chemical and biochemical parameters measured in sea bass spermatozoa and seminal plasma before and after cryopreservation. Values ( $\pm$  SD) in a row with the same letter are not significantly different ( $P > 0.01$ ). N=Number of sperm samples from different males. (This table was originally published in Zilli et al., Biol. Reprod 2004)

## 2.2 Relationship of sperm and seminal plasma parameters and fertilization rate in fresh and cryopreserved semen samples

The most common parameters used to evaluate sperm quality are fertilization ability, motility (rate and duration) and cellular (chemical and/or biochemical) parameters. In sea bass we identified simple and cost-effective markers of sperm quality that would replace conventional motility and fertility evaluation assays, using both fresh and frozen-thawed sperm. Parameters of sperm metabolism and seminal plasma were tested by evaluating correlations with the fertilization rate using simple regression analysis and square relationship analysis.

In fresh sperm, among the measured cellular metabolites and enzymes, only ATP concentration and aspartate aminotransferase activity showed significant linear correlations ( $P < 0.0001$ ) with fertilization rate (Fig. 1) and the calculation of the partial correlation coefficient revealed that these two parameters were not correlated ( $Pr = -0.323$ ). Malate dehydrogenase activity and sperm triglyceride concentration had a quadratic relation with fertilization rate:  $R^2 = 0.31$ ,  $P < 0.001$  for malate dehydrogenase;  $R^2 = 0.28$ ,  $P < 0.01$  for triglyceride concentration (see Zilli et al. 2004 for details).

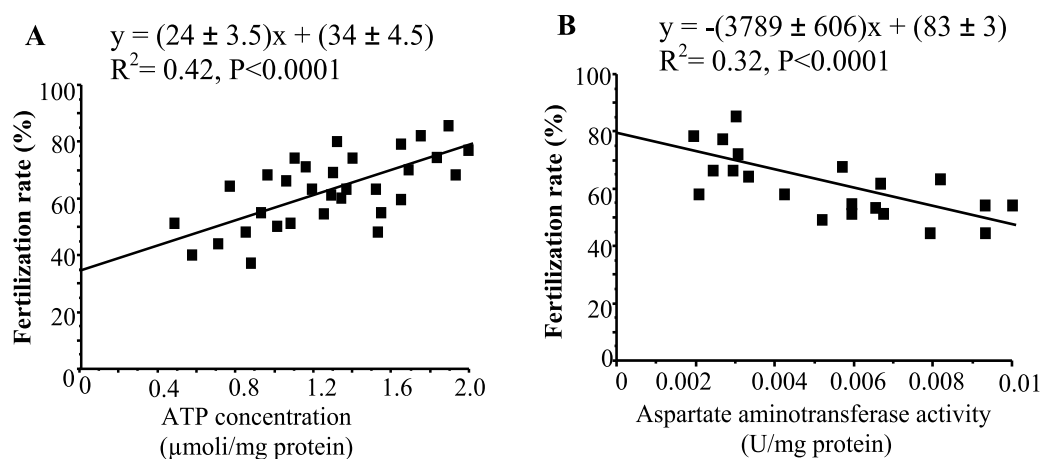

Fig. 1. Relationship between fertilization rate and ATP concentration (A,  $N = 32$ ) or aspartate aminotransferase activity (B,  $N = 21$ ) using sea bass fresh sperm samples. Samples obtained from different males were used to measure the ATP concentration and the aspartate aminotransferase activity and to perform the fertilization trials.  $N$  = Number of sperm samples from different males. (This figure was originally published in Zilli et al., Biol. Reprod 2004).

ATP concentrations of  $> 1.8$  mmol/mg protein characterized sperm with fertilization rates  $\geq 75\%$ . The relationship between ATP concentration and fertilization rate is due to the fact that the flagellar beat frequency of spermatozoa depends on ATP concentration and dynein ATPase activity (Christen et al., 1987; Lahnsteiner et al., 1998). Thus, intracellular ATP concentration could be used instead of sperm motility as a predictor of fertilization ability. Determination of ATP concentration has some advantages over motility assessment: it is not subjective as is motility determination based on microscopic observation (McNiven et al., 1992) and it is faster and less expensive with respect to the Computer Assisted Sperm Analysis system. Aspartate aminotransferase activities of  $0.3$  mU/100 mg protein characterized sperm with fertilization rates of  $75\%$ . A correlation between the activity of this enzyme and fertilization rate was also found in lake whitefish (*Coregonus clupeaformis*) (Ciereszko & Dabrowski, 1994) and rainbow trout (Lahnsteiner et al., 1998). The physiological meaning of this relationship is uncertain.

Among the seminal plasma (tested) parameters, only  $\beta$ -D-glucuronidase activity and potassium concentration had a significant linear relation ( $P < 0.01$ ) with fertilization rate (Fig.

2) and also in this case the calculation of the partial correlation coefficient revealed that these two parameters were not correlated.

$\beta$ -D-Glucuronidase activity is negatively correlated with fertilization rate. This enzyme is involved in hydrolysis of  $\beta$ -glucuronides to glucuronic acid and is located most frequently in lysosomes (Rawn, 1983). It is located in the spermatic duct epithelium, usually in areas where lytic processes occur, and is also secreted into the seminal fluid (Lahnsteiner et al., 1994). A correlation between this activity of this enzyme and fertilization rate was also found in rainbow trout (Lahnsteiner et al., 1998). An increase of seminal plasma  $\beta$ -D-glucuronidase activity indicates degeneration or aging processes in the semen (Lahnsteiner et al., 1998). Seminal plasma potassium concentration concentrations of 17 mM characterized sperm with fertilization rates of 75%. Quadratic functions were used to described the relationship between fertilization rate and potassium concentration in other fish species, i.e., bleak (*Alburnus alburnus*), Atlantic salmon, and rainbow trout (Aas et al., 1991; Lahnsteiner et al., 1998).

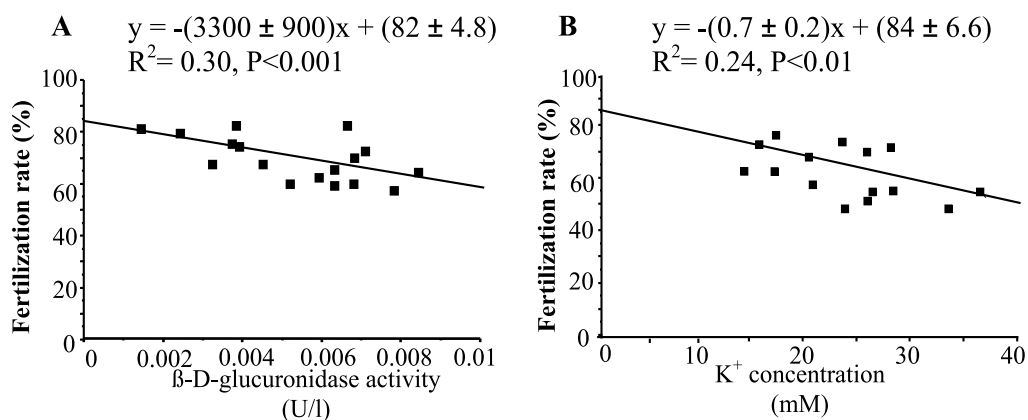

Fig. 2. Relationship between fertilization rate and seminal plasma  $\beta$ -D-glucuronidase activity (A, N=17) or seminal plasma potassium concentration (B, N=15) using fresh sea bass sperm samples. Samples obtained from different males were used to measure  $\beta$ -D-glucuronidase activity and seminal plasma potassium concentration and to perform the fertilization trials. N=Number of sperm samples from different males. (This figure was originally published in Zilli et al, Biol Reprod 2004)

Sperm and seminal plasma parameters of fresh semen that showed linear correlation with the fertilization rate have been also used in multiple regression models to predict the fertilization ability. Three models were tested: the first model included sperm ATP concentration and aspartate aminotransferase activity, the second model included the seminal plasma  $\beta$ -D-glucuronidase activity and potassium concentration while the third model included ATP, aspartate aminotransferase and  $\beta$ -D-glucuronidase (potassium concentration was excluded due to its linear relationship with ATP). Results indicated that sea bass fresh semen fertilization rate was well predicted by the first multiple regression model, which included cellular parameters (see Zilli et al 2004 for details).

Because sperm ATP concentration and seminal plasma  $\beta$ -D-glucuronidase activity among the tested parameters produced the highest correlation coefficients, we also investigated their relationship with fertilization rate in frozen-thawed samples. These parameters showed a linear relationship with fertilization rate also after the freezing-thawing procedure (Fig. 3) similar to what happens for fresh semen.

For practical application the measurements of ATP concentration and seminal plasma  $\beta$ -D-glucuronidase activity represents an alternative simple and cost-effective tests for evaluating sea bass sperm fertilization ability before and after cryopreservation.

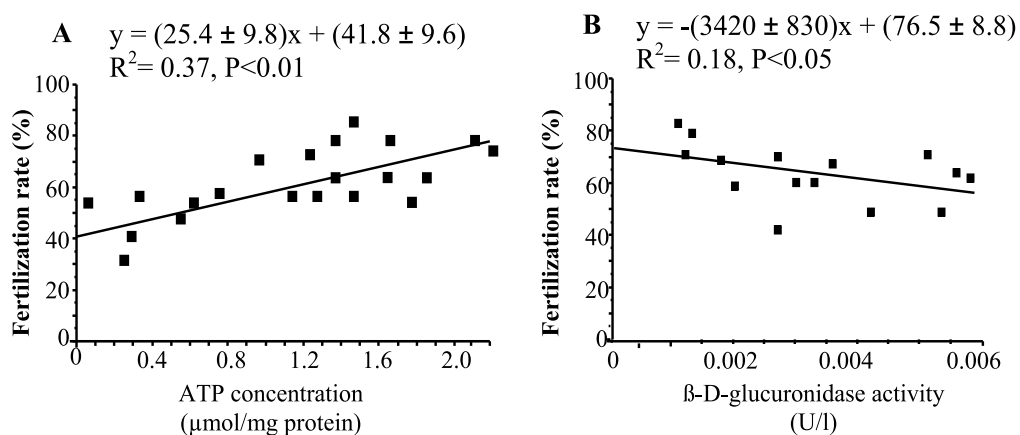

Fig. 3. Relationship between fertilization rate and ATP concentration (A, N=21) or seminal plasma  $\beta$ -D-glucuronidase activity (B, N=15) using cryopreserved sea bass sperm samples. Samples obtained from different males were used to measure the ATP concentration and  $\beta$ -D-glucuronidase activity and to perform the fertilization trials. N=Number of sperm samples from different males. (This figure was originally published in Zilli et al., Biol Reprod 2004).

### 3. Effect of cryopreservation on DNA integrity on sea bass spermatozoa

Sperm DNA fragmentation could be a consequence of the freezing-thawing process and the resulting genome alterations could affect late embryonic development and survival of larvae (Suquet et al., 1998). There are different methods to determine the DNA fragmentation, among these an effective tool is single-cell gel electrophoresis (SCGE). Introduced by Ostling & Johanson in the 1984 it has become a recognized method for detecting DNA damage in a variety of vertebrate cell types, including sperm (Fairbairn et al., 1995; Hughes et al., 1997; Steele et al., 2000). In this assay, the fragmented DNA migrates toward the anode, giving the appearance of a "comet tail" while the undamaged DNA appears as intact comet heads (lacking tail). These comets can be easily visualized when stained with DAPI. By using this technique we have demonstrated (Zilli et al, 2003) that the cryopreservation protocol (Fauvel et al 1998) used to cryopreserve the sea bass sperm cause significantly damage at DNA level (Figure 4). Results, expressed in terms of the "percent tail DNA" (% DNA<sub>T</sub>) and "tail moment" (MT) (Ashby et al., 1995; Helma & Uhl, 2000; Johnson & Ferris, 2002; Piperakis et al., 1999) were reported in table 2.



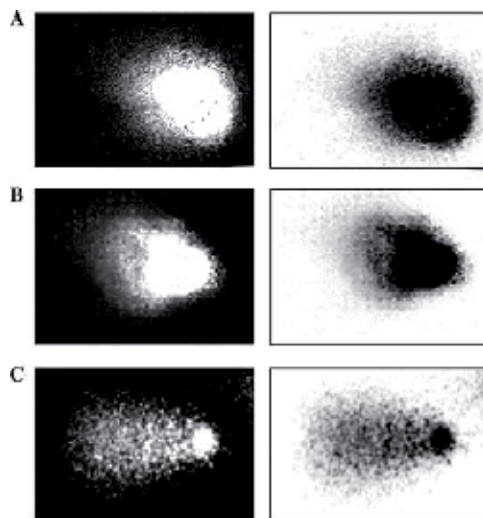

Fig. 4. The appearance of fresh (A), frozen-thawed (B) and unprotected frozen-thawed (C) sea bass sperm following preparation by the SCGE assay. On the right are shown the negative images of the same preparation used to perform the analysis. (This figure was originally published in Zilli et al., Cryobiology 2003)

Parameter analysed	Fresh sperm	Frozen-thawed sperm	Unprotected frozen-thawed sperm
Motile sperm (%)	75±15a	67±18a	n.d.
Fertilization rate (%)	74±15a	70±12a	n.d.
Motility duration (sec)	129±46a	28±8b	n.d.
Percent Tail DNA	32.7±11.1a	38.2±11.2b	65.2±10.2c
Tail Moment	375.2±190.7a	498.9±166.4b	2345.1±725.2c

Table 2. Effect of cryopreservation on DNA integrity, sperm motility and fertilizing ability determined on fresh and frozen-thawed in the presence or absence of cryoprotectant (Me<sub>2</sub>SO). Values in a row with the same letter are not significantly different (P>0.01). n.d.: not detectable. (This table was originally published in Zilli et al., Cryobiology 2003).

The results obtained indicate that the cryopreservation protocol used for sea bass sperm (Fauvel et al 1998): (1) is without effect on both sperm rate motility and fertilizing ability; (2) significantly reduced the duration of motility, (3) is associated with DNA damage that, although significant, is of low magnitude and (4) demonstrated the fundamental role played by cryoprotectant (Me<sub>2</sub>SO) in reducing fish sperm DNA fragmentation. The role played by Me<sub>2</sub>SO was also demonstrated by using DNA laddering (Fig. 5A). When the analysis was performed on fresh semen samples no smearing was detectable (lanes 4 and 5). In some frozen-thawed semen samples (lanes 7 and 11) but not in all (see lanes 6, 8, 9, and 10) a small degree of laddering seems to be present. On the contrary, in unprotected frozen-thawed semen DNA laddering was clearly evident (lane 13).

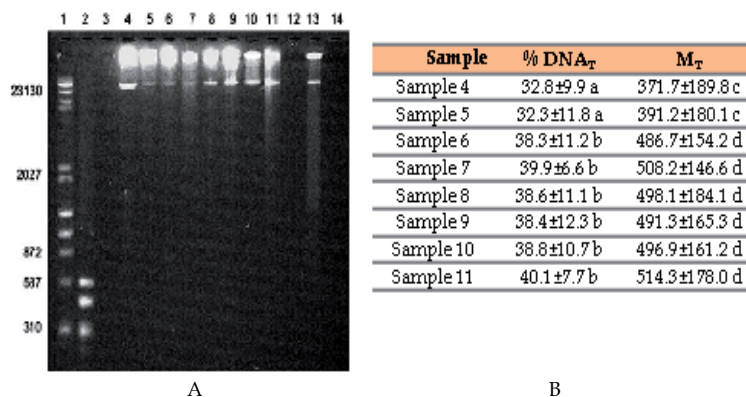

Fig. 5. DNA fragmentation of sea bass sperm samples. (A) Agarose gel electrophoresis of DNA isolated from sea bass sperm. Lanes 1 and 2: DNA molecular weight markers (pb); lanes 4 and 5: 2 lg of DNA isolated from fresh sperm; lanes 6, 7, 8, 9, 10, and 11: 2 lg of DNA isolated from frozen-thawed sperm; lane 13: 2 lg of DNA isolated from unprotected frozen-thawed sperm; (B) SCGE assay in fresh samples (4 and 5) and frozen-thawed samples (6-11) of sea bass sperm. Values are given as mean  $\pm$  SD. Values within a column followed by the same letter are not significantly different ( $P>0.01$ ). (Modified from Zilli et al., Cryobiology 2003)

Since in some frozen-thawed semen samples (lanes 7 and 11 of Fig. 5A) analyzed by DNA laddering analysis, but not in all (lanes 6, 8, 9, and 10), a small degree of laddering seems to occur, we analyzed the same samples with the SCGE method. The results reported in Fig 5B confirmed the presence of DNA fragmentation in the samples 7 and 11; in addition it revealed a significant degree of DNA fragmentation in the samples 6, 8, 9, and 10 with respect to fresh samples (4 and 5). In any case it must be underlined that within the frozen/thawed samples (6, 7, 8, 9, 10, and 11) no statistically significant differences in the DNA fragmentation was revealed by the SCGE method (Fig 5B).

DNA laddering has been used in many studies to obtain a qualitative analysis of DNA fragmentation (Duke & Cohen, 1986; Homma-Takeda et al., 2001; Sun et al., 1999). It is a very simple method, but the most critical problem with DNA electrophoretical analysis are its inability to provide quantitative measurement and its low sensitivity. In fact, random double-stranded or rare single-stranded DNA fragmentation in cells, cannot be detected by this technique. On the contrary, the SCGE or Comet assay has been recognized as one of the most sensitive techniques for measuring DNA strand breaks (Collins et al., 1997). For human sperm, comet assay has been shown to have a significant relationship both to the SCSA (Sperm Chromatin Structure Assay) (Larson et al., 2001) and the TUNEL assay (Terminal Deoxynucleotidyl Transferase-mediated Nick End Labelling), another technique for detecting the incidence of DNA fragmentation (Sakkas et al., 1999). The use of the Comet assay in alkaline conditions is a useful tool to carry out a quantitative analysis of DNA fragmentation. Previous works (Collins et al., 1997; McKelvey-Martin et al., 1993) have reported that the assay resolves break frequencies up to a few hundred per cell, definitely well beyond the range of fragment size for which conventional electrophoresis is suitable. Since introduction of the Comet assay protocol (Ostling & Johanson, 1984), there have been modifications of it for use with various cell types, including sperm (Fairbairn et al., 1995; Hughes et al., 1997; Steele et al., 2000). We have adapted to fish sperm the method developed by Steele et al. (2000) and we have evaluated the effect of cryopreservation on sea bass sperm DNA.

A small but significant effect of cryopreservation on DNA integrity has been demonstrated in studies carried out by Labbe et al. (2001) using sperm trout. They tested how the sperm cryopreservation affected the nuclear DNA stability and whether the progeny development was modified when eggs were fertilised with cryopreserved spermatozoa. They concluded that cryopreservation of trout sperm only slightly affected sperm DNA stability and that the use of cryopreserved sperm did not impair offspring survival and quality. Analogous studies carried out on sperm of other fish species have not revealed DNA damage after cryopreservation. The freeze-thaw process did not cause genome alterations in turbot sperm since the fertilisation rate, the hatching rate, the larval survival rate (up to ten days) and the larval weight, were similar with both fresh and frozen-thawed sperm (Suquet et al., 1998). Similarly, no effect of the freeze-thaw process on the nucleus of Atlantic croaker spermatozoa was reported (Gwo et al., 2003). Moreover, the growth of tilapias (up to 800 g) and channel catfish (up to 130 g) were not altered using thawed spermatozoa (Chao et al., 1987; Tiersch et al., 1994). The DNA damage that we observed in the cryopreserved sea bass sperm did not affect fertilization capacity and motility. Different authors have reported that the DNA fragmentation is associated with a decrease of fertilization ability, abnormal embryo cleavage and decreased embryo survival (Gwo et al., 2003; Kopeika et al., 2003a, 2003b, 2004; Sun et al., 2000). Fauvel et al. (1998b) found a lower hatching rate for eggs inseminated with frozen-thawed sea bass sperm (69%) when compared with those obtained with fresh sperm (81%), although the fertilisation rates were similar. The presence of the significant degree of DNA fragmentation that we measured after cryopreservation of sea bass sperm could explain, at least partially, this observation. Since the establishment of fish sperm cryobanks could play a crucial role in the genetic management and conservation of aquatic resources the advancement of cryopreservation protocols that avoid DNA fragmentation/aberration are necessary and the SCGE technique is a useful tool to reach this goal.

#### **4. Effect of cryopreservation on sea bass protein profile**

Defects in sperm proteins may compromise sperm motility, fertilization ability, and the early events after fertilization (Cao et al., 2003; Huanget al., 1999; Lessard et al., 2000). Protein screening has become an excellent approach with which to evaluate changes in expression due to different stresses. Using this method it has been demonstrated that the reduction in motility observed in boar and human spermatozoa following cryopreservation was associated with a decrease in heat shock protein 90 during cooling (Cao et al., 2003; Huanget al., 1999). Similarly, the loss of P25b (a protein associated with the plasma membrane covering the acrosome) may be responsible, at least in part, for the decrease in fertility following the freezing/thawing procedure of bull semen (Lessard et al., 2000). Cryoinjuries due to cryopreservation have been reported for thawed spermatozoa of many freshwater (Rana, 1995) and marine fish species (Gwo et al., 1992; Lahnsteiner et al., 2000). Shrinkage of the plasma membrane of the midpiece, breakage of mitochondria, and coiling of the axoneme have been observed. Cryopreserved sea bass sperm showed similar fertilization rates and class motility compared with fresh sperm, but also showed a decline in motility duration (Fauvel et al., 1998a), changes in metabolism (Zilli et al., 2004), and lower hatching rates (Fauvel et al., 1998b). For these reasons we used (Zilli et al., 2005) the 2-DE to verify whether the cryopreservation procedure, applied to sea bass milt, affected the expression of proteins involved in the control of sperm functions and, in addition, matrix-associated laser desorption/ionization time-of-flight (MALDI-TOF) mass spectrometry to identify some of these proteins.

#### 4.1 Proteins expression in two-dimensional electrophoresis gels: Differences between fresh and frozen-thawed sea bass sperm samples

To perform two-dimensional analysis sperm samples with similar fertilization rates (70%–90%) and percentage of motility (80%–100%), before and after cryopreservation, were used to extract proteins. All the sperm samples used showed lower motility duration after the cryopreservation procedure. 163 spots were detected in all gels prepared from fresh samples (with molecular masses ranging between 190 and 10 kDa and isoelectric points between 3.5 and 8.0) and were used for comparative analysis. Results of a typical experiment performed on sperm samples before and after cryopreservation are showed in figure 6 (A and B).

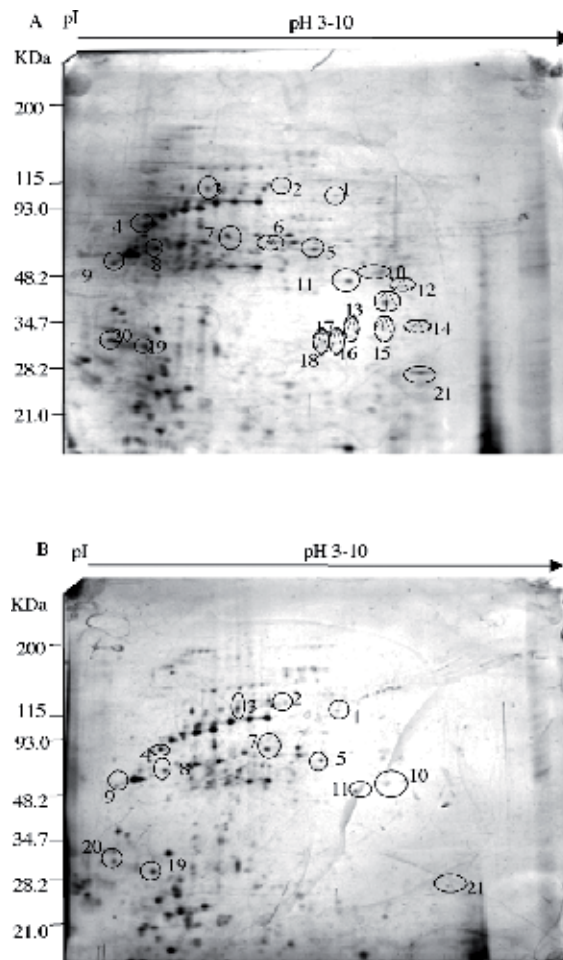

Fig. 6. Two-dimensional Electrophoresis (2-DE) maps of fresh (A) and cryopreserved (B) sea bass sperm proteins. 2-DE was performed on an immobilized pH 3–10 strip, followed by the second-dimensional separation on 12.5% polyacrylamide gels. The separated proteins were stained with silver staining. Spots that are less expressed after cryopreservation are highlighted with a continuous line; spots that are entirely absent after cryopreservation are marked with a dotted line. (This figure was originally published in Zilli et al., *Biol Reprod* 2005).

Differences were observed (by visual inspection and by using image analysis software) in the protein profiles of fresh and cryopreserved sperm samples. In fact, in the cryopreserved sperm samples, among the 163 spots considered, 13 were significantly ( $P < 0.05$ ) less expressed, and 8 completely disappeared. These 21 spots are highlighted in Figure 6 and the normalized spot volumes listed in Table 3. A decrease in protein abundance or spot disappearance in sperm after the cryopreservation procedure may be due to either leakage of proteins from spermatozoa to the extracellular medium or to degradation following freezing-thawing stress. The leakage of proteins is ruled out because we have previously demonstrated that the intracellular protein concentration and the seminal plasma protein concentrations do not change after cryopreservation (Zilli et al., 2004). Consequently, protein degradation seems to be responsible for the reduction in spot abundance (and disappearance). Similar results have been also reported in human and boar semen (Cao et al., 2003; Huanget al., 1999) and bull sperm (Lessard et al., 2000).

Spot Number	Normalised spot volume in fresh sperm (N=6)	Normalised spot volume in cryopreserved sperm (N=6)
SPOT 1	17.8±2.1	7.0±1.1
SPOT 2	10.7±1.1	5.9±1.5
SPOT 3	48.0±9.1	20.2±5.1
SPOT 4	40.8±5.2	29.3±4.1
SPOT 5	54.9±11.3	20.6±3.0
SPOT 6	42.9±2.2	-
SPOT 7	36.8±3.3	25.5±5.2
SPOT 8	110.0±23.0	33.4±6.3
SPOT 9	52.7±12.0	38.7±9.0
SPOT 10	31.9±8.0	4.7±2.0
SPOT 11	30.6±7.0	7.4±5.0
SPOT 12	34.9±15.2	-
SPOT 13	44.3±13.	-
SPOT 14	34.3±11.3	-
SPOT 15	11.4±3.2	-
SPOT 16	8.4±2.8	-
SPOT 17	6.2±3.5	-
SPOT 18	11.8±4.2	-
SPOT 19	30.6±7.2	10.6±4.2
SPOT 20	102.8±3.6	42.9±3.3
SPOT 21	46.3±6.6	29.2±7.3

Table 3. Differences in abundance of spots in fresh and cryopreserved sea bass sperm. Spot abundance is expressed as mean  $\pm$  SD of normalized spot volume measured in six different gels. (This table was originally published in Zilli et al., Biol Reprod 2005).

#### 4.2 Identification of protein spots by MALDI-TOF

Five of the protein spots shown in Table 3 were analyzed by MALDI-TOF for protein identification. Three were selected among the spots that significantly decreased after cryopreservation (5, 8, and 20) and two (6 and 13) were taken from among those that were absent in the gel obtained with frozen-thawed sperm (Fig. 6 and Table 3). Protein identification was performed by three search programs (PeptIdent, Mascot, and MS-Fit).

Three out of five sea bass proteins processed were found to have homologies with existing sequences in the databases used (Table 4). These proteins were identified from protein sequences already described in other teleost species and amphibians. In particular, two were from *Brachidanio rerio* (spots 5 and 20) and one was from *Xenopus laevis* (spot 13). Table 4 summarizes the data of the bio-informatics analysis for these proteins. For spot 5, the search engine PeptIdent found a homology with a protein of *Brachidanio rerio* (similar to SKB1 of human and mouse). This is a highly conserved cytoplasmic protein with methyltransferase activity that interacts with the members of the Janus family tyrosine kinases (JAK) (Pollack et al., 1999). Genome activation is one of the first critical events in the life of a new organism. Both the timing of genome activation and the array of genes activated must be controlled correctly, and these events depend on changes in chromatin structure and availability of transcription factors (Latham & Schultz, 2001).

In sea bass the observed reduction in SBK1 proteins in cryopreserved sperm could be responsible for abnormal early embryo development, which in turn, could determine the lower hatching rate observed (personal observation). The spot protein 13 matched in Mascot and MS-Fit with a G1/S-specific cyclin E2 protein, which is essential in the control of the cell cycle at the G1/S (start) transition (Moore et al., 2002). Cyclin E is involved in the activation of cyclin-dependent kinase 2 (cdk2). Recently, it has been demonstrated that cdk2 phosphorylates the protein phosphatase, PP1gamma2, a key enzyme in the development and regulation of sperm motility (Huang & Vijayaraghavan, 2004). The observed reduction in sea bass sperm motility duration in frozen-thawed spermatozoa could be a consequence of the cyclin E degradation. The protein spot 20 matched, in MS-Fit, with the hypothetical protein DKFZp566A1524 of unknown function.

Reference Spot	EWM (kDa)	EIP	Identified protein	SWISSPR-OT accession no.	Species ident-ified	TWM (kDa)	TIP	Homology	
								Matched peptides	Coverage %
SPOT 5	80	6.5	Novel protein similar to SKB1 human and mouse (PEPTIDENT)	Q7ZZ07	<i>Brachidanio rerio</i>	71.8	5.98	8	22.0
SPOT 6	110	6.0	–	–	–	–	–	–	–
SPOT 8	100	5.2	–	–	–	–	–	–	–
SPOT 13	40	6.8	G1/S-specific cyclin E2 (MASCOT, MS-FIT)	Q91780	<i>Xenopus laevis</i>	47.78	6.3	6	20.0
SPOT 20	30	4.5	Similar to hypothetical protein DKFZp566A1524 (MS-FIT)	Q96AZ5	<i>Brachidanio rerio</i>	37.13	5.6	4	21.0

Table 4. Results from peptide mass fingerprinting of protein spots excised from 2D gels. EWM: Experimental Weight Mass; EIP: Experimental Isoelectric Point; TWM: Theoretical Weight Mass; TIP: Theoretical Isoelectric Point. (This table was originally published in Zilli et al., Biol Reprod 2005).

The results reported in figure 6 and tables 3 and 4 show that in sea bass spermatozoa the used cryopreservation procedure causes the degradation of 21 sperm proteins, and among these, 2 could be at least partially responsible for the observed decrease in sperm motility duration and the lower hatching rate of eggs fertilized with cryopreserved sperm. In addition, these observations suggest that two-dimensional electrophoresis coupled with MALDI-TOF analysis could be used as a tool to improve cryopreservation procedures.

## **5. Effect of cryopreservation on proteins phosphorylation state of sea bream sperm**

### **5.1 Molecular mechanisms determining sperm motility initiation in sea bream *sparus aurata***

Most fish spermatozoa are quiescent in the testes, because the osmolality and composition of seminal plasma usually prevent motility in sperm ducts (Billard, 1986). During natural reproduction, fish sperm become motile after discharge into the aqueous environment (in oviparous species) or the female genital tract (in viviparous and ovoviviparous species) (Billard, 1986; Billard & Cosson, 1983; Stoss, 1983). Changes in the ionic and osmotic environment of the sperm cells have been identified as being critical external factors that may be responsible for initiating motility in fish spermatozoa (Morisawa, 1994). Several extracellular factors controlling sperm motility have been reported. In marine (Gwo et al, 1993; Krasznai et al, 2003a, 2003b; Morisawa & Suzuki, 1980; Oda & Morisawa, 1993) and freshwater (Billard, 1986; Morisawa et al., 1983; Stoss, 1983) teleosts, sperm motility is initiated by osmotic shock when sperm are ejaculated. In these species, spermatozoa are quiescent at the osmolality of seminal plasma (referred to as isotonic condition). In freshwater teleost sperm, flagellar motility is initiated by the hypo-osmotic shock, whereas in marine teleost sperm, flagellar motility is initiated by hyperosmotic shock. Furthermore, in medaka (Inoue & Takei, 2003) and tilapia (Linhart et al., 1999), motility regulatory mechanisms of sperm flagella are modulated to suit the spawning environment when they are in freshwater or acclimated to seawater. In herring sperm, motility initiation requires trypsin inhibitor-like sperm-activating peptide from the eggs (HSAPS), and the sperm exhibits chemotaxis when they are close to eggs (Oda et al., 1998; Yanagimachi et al., 1992). The extracellular factors controlling sperm motility (osmolality, ions, sperm-activating peptides, and chemoattractants) act on the flagellar motile apparatus, the axoneme, through signal transduction across the plasma membrane. Second messengers, such as cAMP and Ca, play key roles in the initiation of sperm motility in many animal groups, such as mammals (Lindemann, 1978; Okamura et al., 1985; Tash & Means, 1983), salmonid fish (Morisawa & Okuno, 1982), sea urchin (Cook et al., 1994), mussel (Stephens & Prior, 1992), and tunicate (Opresko & Brokaw, 1983). A cAMP-independent initiation of flagellar motility in sperm was observed in puffer fish (Morisawa, 1994) and striped bass (Shuyang et al., 2004). Second messengers (cAMP and Ca) determine the sperm motility initiation modifying dynein-mediated sliding of the axonemal outer-doublet microtubules through protein phosphorylation/dephosphorylation in different species, such as mammals (Lindemann & Kanous, 1989), rainbow trout, chum salmon, sea urchin (Inaba et al., 1999), and tunicate (Nomura et al., 2000).

In *Sparus aurata* osmolality is the key signal in sperm motility activation and motility initiation depends on a cAMP-dependent protein phosphorylation (Zilli et al., 2008). To elucidate which proteins are involved (phosphorylated/dephosphorylated) in the initiation

of sea bream spermatozoa motility, proteins extracted from spermatozoa before and after motility activation were separated on SDS PAGE, blotted on nitrocellulose membrane, and treated with anti-phosphotyrosine, anti-phosphothreonine, or anti-phosphoserine antibodies.

After motility activation we observed that: 1) two protein bands (76 kDa and 57 kDa) were dephosphorylated and an unspecified number of proteins corresponding to a large band of 9-15 kDa were phosphorylated at tyrosine residues (Fig. 7A); 2) two protein bands (174 kDa and 147 kDa) resulted phosphorylated and an unspecified number of proteins with molecular weights ranging between 15 and 9 kDa were dephosphorylated at threonine residues (Fig. 7B); 3) three protein bands (174 kDa, 138 kDa and 70 kDa) and an unspecified number of proteins from 9 to 12 kDa were phosphorylated and only one protein band of 33 kDa was dephosphorylated at serine residues (Fig. 7C).

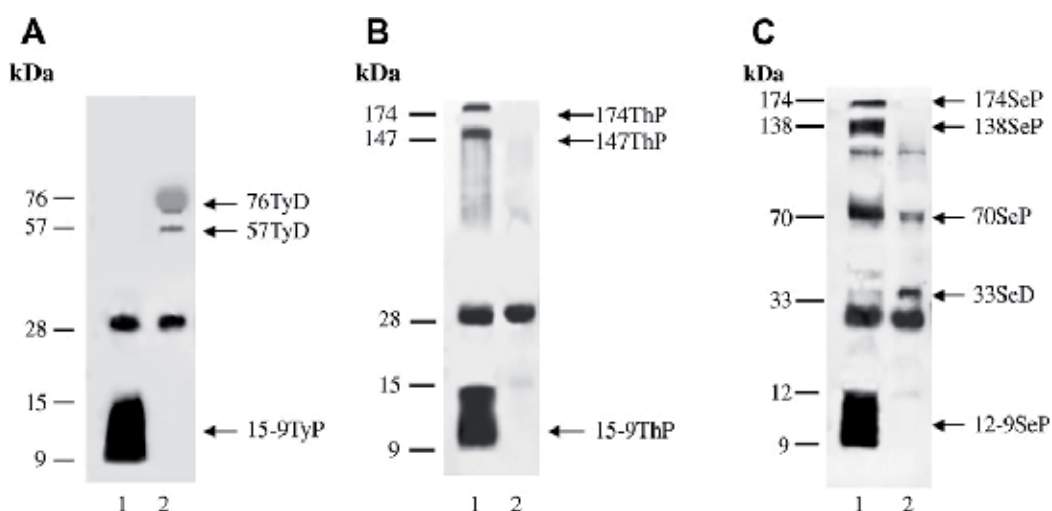

Fig. 7. Motility-dependent phosphorylation/dephosphorylation at tyrosine residues (A), threonine residues, (B) and serine residues (C) in fresh sperm of gilthead sea bream before and after motility activation. Sperm were either activated in seawater (lane 1) or maintained immotile by dilution in non-activating medium (lane 2). Sperm proteins were subjected to Western blotting (30  $\mu$ g/lane) with anti-phosphotyrosine, anti-phosphothreonine and anti-phosphoserine antibodies. Number on the left indicates the molecular mass of bands. On the right, the names of proteins of interest are indicated. (This figure was originally published in Zilli et al., *Cryobiology* 2008).

We characterized some of these proteins by using two-dimensional gel electrophoresis (2DE) and the antibody against phosphothreonine. This antibody revealed (figure 8) that: 1) the protein band of 174 kDa (named that 1ThP in figure 7 and identified as 1THPSa in figure 8) was not a single protein but, rather, a cluster of proteins with the same molecular weight (174 kDa) but different pI (5.9–6.29); 2) the protein band of 147 kDa (named 2ThP in figure 7 and identified as 2THPSa in figure 8) was a protein with a pI of 8.7; and 3) the cluster of proteins of 9-15 kDa (named 3ThP in figure 7 and identified as 3THPSa in figure 8) consisted of 10 proteins with pI between 6.1 and 7.6 and molecular weights between 9 and 15 kDa.



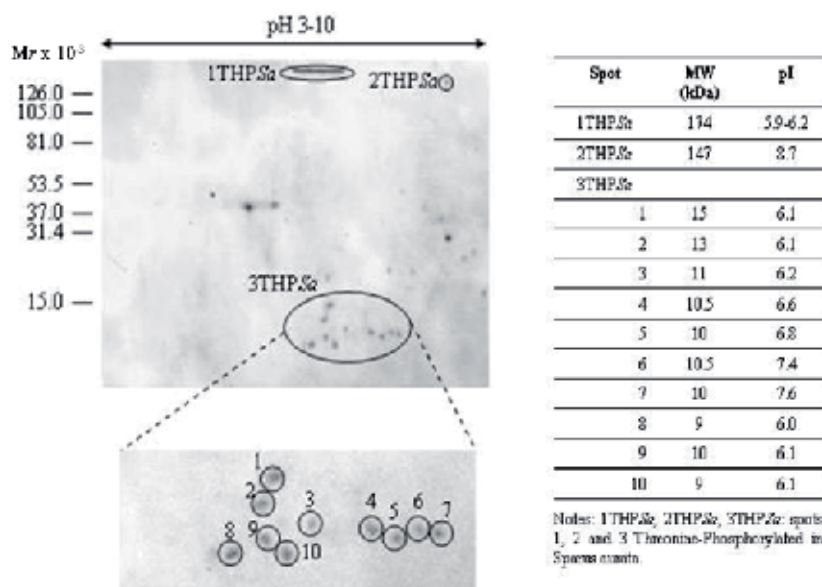

Fig. 8. Western blot analysis with antiphosphothreonine antibody of gilthead sea bream (*Sparus aurata*) sperm proteins separated by 2DE. The 2DE was performed on an immobilized pH 3–10 NL strip, followed by the second-dimensional separation on 13% polyacrylamide gels. The separated proteins were then blotted on nitrocellulose and incubated with antibody. Molecular mass and isoelectric point of proteins of interest are listed. (This figure was originally published in Zilli et al., Biol. Reprod. 2008).

Some of these proteins have been identified by mass spectrometry and results are listed in Table 5. In particular, spots 1 and 2 (belonging to 3THPSa) were identified as acetyl-coenzyme A (CoA) synthetase, spot 5 as A kinase anchor protein (AKAP), and spot 7 as an unnamed protein of *Tetraodon nigroviridis*, which have 70% identity with a novel protein similar to phosphatase and actin regulator 3 of *Danio rerio*. Acetyl-CoA synthetase is well known as an enzyme whose activity is central to the metabolism of prokaryotic and eukaryotic cells. In particular, acetyl-CoA synthetase activates acetate to acetyl-CoA, and it provides the cell with the two-carbon metabolite used in many anabolic and energy generation processes. Therefore, we suppose that this enzyme was activated in motile sperm to increase the level of ATP, which is necessary for flagellar movement. PKA localizes to specific cellular structures and organelles by binding to AKAP molecules via interaction with the regulatory subunits (RI and RII). Therefore, cAMP levels temporally regulate PKA, whereas the spatial regulation within the cell occurs through compartmentalization by binding to AKAP, thus assuring specificity of PKA function. The important role of AKAP as a key regulator of sperm motility is already established (Vijayaraghavan et al., 1997a). In addition, a recent study demonstrated that phosphorylation of AKAP in human sperm results in tail recruitment of PKA and increase of sperm motility, providing evidence for a functional role of phosphorylation of AKAP (Luconi et al., 2004). Regarding the role of phosphatases and kinases in the initiation of sperm motility, many studies have demonstrated that the development and maintenance of motility is regulated by a complex

balance between kinase and phosphatase activities (Tash & Brach, 1994; Vijayaraghavan et al., 1997b).

Reference Spot	EWM (kDa)	EIP	Identified protein	SWISSPROT accession no.	Species identified	TWM (kDa)	TIP	Homology	
								Score	Coverage %
3THPSa									
Spot1/ Spot2	15-13	6.1	LOC568763 similar to Acetyl-coenzyme A synthetase	Q0VG88	<i>Danio rerio</i>	15.5	5.3	0.97a	27%
Spot 5	10	6.8	novel protein similar to human A kinase (PRKA) anchor protein 7 (AKAP7)	CAI11962	<i>Danio rerio</i>	8.1	6.0	0.79a	26%
Spot 7	10	7.6	Chromosome 11 SCAF14528, whole genome shotgun sequence - Unnamed protein product that have a 70% of identity with novel protein similar to phosphatase and actin regulator 3 (PHACTR3, zgc:109967) [ <i>Danio rerio</i> ]	Q4SQZ9	<i>Tetraodon nigroviridis</i>	8.0	7.7	0.28b	21%

Table 5. Results from peptide mass fingerprinting of protein spots excised from 2-D gels of gilthead sea bream sperm.

EWM: Experimental Weight Mass; EIP: Experimental Isoelectric Point; TWM: Theoretical Weight Mass; TIP: Theoretical Isoelectric Point. a: Z score of ProFound; b: Normalized score of Aldente. (Modified from Zilli et al., Biol. Reprod. 2008).

## **5.2 Effect of cryopreservation on phosphorylation state of proteins involved in sperm motility initiation in sea bream *Sparus aurata***

The quality of gilthead sea bream semen was decreased by cryopreservation procedure. Even though the viability ( $82 \pm 5\%$ ) of spermatozoa following the freezing-thawing procedure was only slightly (but significant) decreased with respect to that measured in fresh samples ( $93 \pm 4$ ), only the 50% of the thawed spermatozoa could be activated, and showed a motility duration which was one third of that measured in fresh samples. The reduction of sperm motility (percent and duration) is attributable (at least partially) to the effect that the freezing-thawing procedure has on the phosphorylation state of proteins involved in motility initiation (Zilli et al., 2008b).

### **Phosphorylation/dephosphorylation of tyrosine residues:**

Two protein bands (76TyD and 57TyD of figure 7A) which in fresh sperm were completely dephosphorylated after motility initiation, in frozen-thawed remained phosphorylated (Fig. 9A), while the cluster of proteins of 15-9 TyP (Fig. 7A), that were phosphorylated when fresh sperm shifted from the immotile to the motile phase, were much less phosphorylated in frozen-thawed activated sperm (Fig. 9A).

### **Phosphorylation/dephosphorylation of threonine residues:**

Among the proteins that were phosphorylated following motility activation in fresh sperm (Fig. 7B), two bands (named 15-9ThP and 147ThP) were phosphorylated after activation in frozen-thawed spermatozoa (Fig. 9B). However, it must be underlined that within the proteins belonging to the 15-9 ThP band, only one (11 kDa) previously identified as acetyl-coenzyme A synthetase (Zilli et al, 2008a) was phosphorylated after motility activation in cryopreserved sperm (Fig. 9B).

### **Phosphorylation/dephosphorylation of serine residues:**

Among the five previously identified protein bands (Zilli et al, 2008a) that changed their phosphorylation state after motility activation in fresh sperm (Fig. 7C), only two (70SeP and 12-9SeP) were phosphorylated in frozen-thawed sperm after activation (Fig. 9C). The other bands, named 174SeP, 138SeP and 33SeD, did not change their phosphorylation state after activation (Fig. 9C), unlike what happens in fresh sperm (Fig. 7C).

Some proteins (76TyD, 57TyD and 33SeD) that were dephosphorylated after motility activation in fresh sperm (7A and 7C) but not in cryopreserved spermatozoa (9A and 9C) could not play a key role in sperm motility initiation but could be involved in sperm motility duration and motility characteristics, since the kinematic parameters were significantly reduced by the freezing-thawing procedure.

Our studies also demonstrated that in gilthead sea bream spermatozoa the freezing-thawing procedure increased, independently from the motility activation procedure, protein phosphorylation (mainly at threonine residues), since more phosphorylated proteins were present in non-activated cryopreserved sperm with respect to the fresh sperm. This could be

due, as previously proposed by Perez-Pe et al., (2002), to a membrane modifications that determine conformational changes of these proteins or facilitate calcium influx into the cell (Bailey & Buhr, 1994; McLaughlin & Ford, 1994). This ion could stimulate adenylyl cyclase to initiate cAMP-mediated phosphorylation of sperm protein. Alternatively (or in addition), the cryopreservation procedure could also determine the activation of protein kinases different from PKA (Pommer et al., 2003).

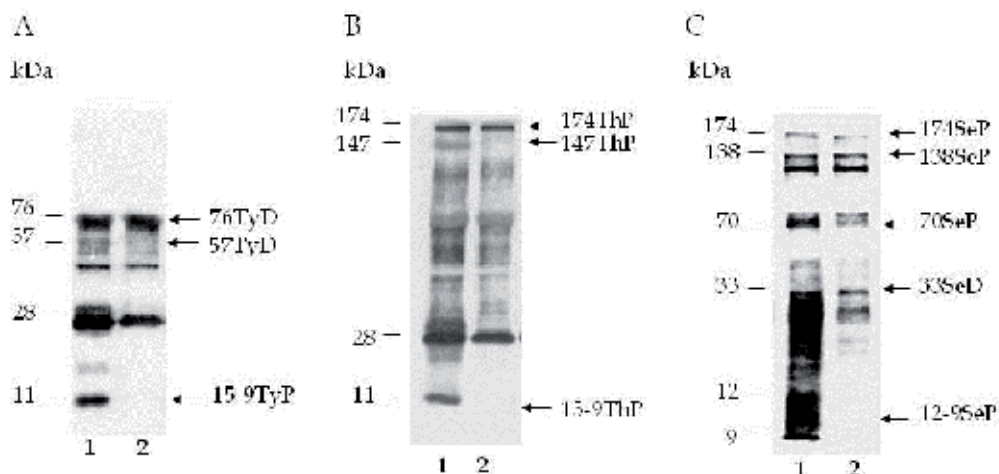

Fig. 9. Motility-dependent phosphorylation/dephosphorylation at tyrosine residues (A), threonine residues (B), and serine residues (C) in frozen-thawed sperm of gilthead sea bream before and after motility activation. Sperm were either activated in seawater (lane 1) or maintained immotile by dilution in non-activating medium (lane 2). Sperm proteins were subjected to Western blotting (30  $\mu$ g/lane) with antibody. Number on the left indicates molecular mass of bands. On the right, the names of proteins of interest are indicated. (Modified from Zilli et al 2008; *Criobiology*)

## 6. Conclusions

Cryopreservation, coupled with insemination and short term storage techniques, will lead to an improvement of gamete management of marine fish species. In particular, sperm cryopreservation is considered as a valuable technique for artificial reproduction and genetic improvement since it allows the selection and the storage of gametes of high quality.

However, although seawater fish spermatozoa of marine fish are more resistant than freshwater species to the dynamic changes in osmotic pressure that occur during the process of cryopreservation (Dzuba & Kopeika, 2002), the freezing-thawing procedure, apart from the experimental protocol used and from the fish species considered, determines: a changes of the kinematic characteristics, damages to proteins and DNA, lipid modification and change of the phosphorylation state of proteins involved in sperm motility initiation. The knowledge of the effects of freezing-thawing procedure on spermatozoa is very important to improve cryopreservation techniques for semen of marine fish for the establishment of sperm cryobanks that could play a crucial role in the genetic management and conservation of aquatic resources.

## 7. References

- Aas, G.H., Reftsie, T. & Gjerde, B. (1991). *Evaluation of milt quality of Atlantic salmon*. *Aquaculture* 95, 125-132
- Ashby, J., Tinwell, H., Lefevre, P.A. & Browne, M.A. (1995). *The single cell gel electrophoresis assay for induced DNA damage (comet assay): measurement and tail length and moment*. *Mutagenesis* 10, 85-90
- Babiak, I. & Glogowski, J. (1997). *Effect of individual male variability on cryopreservation of northern pike, *Esox lucius* L., sperm*. *Aquacult Res* 28, 191-197
- Bailey, J.L. & Buhr, M.M. (1994). *Cryopreservation alters the  $Ca^{2+}$  flux of bovine spermatozoa*. *Can. J. Anim. Sci.* 74, 45-51
- Baynes, S.M. & Scott, A.P. (1987). *Cryopreservation of rainbow trout spermatozoa: the influence of sperm quality, egg quality and extender composition on post-thaw fertility*. *Aquaculture* 66, 53-67
- Billard, R. & Cosson, M.P. (1990). *The energetics of fish sperm motility*. In: Gagnon C (ed), *Control of Sperm Motility: Biological and Clinical Aspects*. CRC Press, Boca Raton, FL, pp. 153-173.
- Billard, R. (1986). *Spermatogenesis and spermatology of some teleost fish species*. *Reprod. Nutr. Dev.* 2, 877-920
- Birktoft, J.J., Fu, Z., Carnahan, G.E., Rhodes, G., Roderick, S.L. & Banaszak, L.J. (1989). *Comparison of the molecular structures of cytoplasmic and mitochondrial malate dehydrogenase*. *Biochem. Soc. Trans.* 17, 301-304
- Bleile, D.M., Shultz, J.H. & Harrison, J. (1977). *Investigation of the subunit interactions in malate dehydrogenase*. *J. Biol. Chem.* 252, 755-758
- Braude, P., Bolton, V. & Moore, S. (1988). *Human gene expression first occurs between the four- and eight-cell stages of pre-implantation development*. *Nature* 332, 459-461
- Cao, W.L., Wang, Y.X., Xiang, Z.Q. & Li, Z. (2003) *Cryopreservation-induced decrease in heat-shock protein 90 in human spermatozoa and its mechanism*. *Asian J. Androl.* 5, 43-46
- Chao, N.H. & Liao, I.C. (2001). *Cryopreservation of finfish and shellfish gametes and embryos*. *Aquaculture* 197, 161-189
- Chao, N.H., Chao, W.C., Liu, K.C. & Liao, I.C. (1987). *The properties of tilapia sperm and its cryopreservation*. *J. Fish Biol.* 30, 107-118
- Christen, R., Gatti, J.L. & Billard, R. (1987). *Trout sperm motility. The transient movement of trout sperm motility is related to changes in concentrations of ATP following the activation of flagellar movement*. *Eur. J. Biochem.* 166, 661-667
- Ciereszko, A. & Dabrowski, K. (1994) *Relationship between biochemical constituents of fish semen and fertility: the effect of short-term storage*. *Fish Physiol. Biochem.* 12, 357-367
- Ciereszko, A., Toth, G.P., Christ, S.A. & Dabrowski, K. (1996). *Effect of cryopreservation and theophylline on motility characteristics of lake sturgeon (*Acipenser fulvescens*) spermatozoa*. *Theriogenology* 45, 665-672
- Collins, A.R., Dobson, V.L., Dusinska, M., Kennedy, G. & Stetina, R. (1997). *The comet assay: what can it really tell us?* *Mutat. Res.* 29, 183-193
- Conget, P., Fernfindez, M., Herrera, G. & Minguell, J.J. (1996). *Cryopreservation of rainbow trout (*Oncorhynchus mykiss*) spermatozoa using programmable freezing*. *Aquaculture* 143, 319-329
- Cook, S.P., Brokaw, C.J., Muller C.H. & Babcock D.F. (1994). *Sperm chemotaxis: egg peptides control cytosolic calcium to regulate flagellar responses*. *Dev. Biol.* 165, 10-19

- Cosson, J., Linhart, O., Mims, S.D., Shelton, W.L. & Rodina, M. (2000). *Analysis of motility parameters from paddlefish (Polyodon spathula) and shovelnose sturgeon (Scaphirhynchus platyrhynchus) spermatozoa*. J. Fish Biol. 56, 1348–1367
- Drokin, S., Stein, H. & Bartseherer, H. (1998). *Effect of cryopreservation on the fine structure of spermatozoa of rainbow trout (oncorhynchus mykiss) and brown trout (salmo trutta F. fario)*. Cryobiology 37, 263–270
- Duke, R.C. & Cohen, J.J. (1986). *Endogenous endonuclease-induced DNA fragmentation: an early event in cell-mediated cytotoxicity*. Proc. Natl. Acad. Sci. USA 80, 61–63
- Dzuba, B.B. & Kopeika, E.F. (2002). *Relationship between the changes in cellular volume of fish spermatozoa and their cryoresistance*. Cryo Letters 23, 353–360
- Fairbairn, D.W., Olive, P.L. & O'Neill, K.L. (1995). *The comet assay: a comprehensive review*. Mutat. Res. 339, 37–59
- Fauvel, C., Suquet, M., Dreanno, C., Zonno, V. & Menu, B. (1998a). *Cryopreservation of sea bass (Dicentrarchus labrax) spermatozoa in experimental and production conditions*. Aquat. Living Resour. 11, 387–394
- Fauvel, C., Zonno, V., Suquet, M., Storelli, C. & Dreanno, C. (1998b). *Cryopreservation of sea bass (Dicentrarchus labrax) sperm in both experimental and production conditions*. In: Proceedings of the Eighth International Symposium on Fish Physiology, Upsala, p. 64.
- Gwo, J.C. & Arnold, C.R. (1992). *Cryopreservation of Atlantic croaker spermatozoa: evaluation of morphological changes*. J. Exp. Zool. 264, 444–453
- Gwo, J.C., Kurokura, H. & Hirano, R. (1993). *Cryopreservation of spermatozoa from rainbow trout, common carp, and marine puffer*. Nippon Suisan Gakkaishi 59, 777–782
- Gwo, J.C., Wu, C.Y., Chang, W.S. & Cheng, H.Y. (2003). *Evaluation of damage in Pacific oyster (Crassostrea gigas) spermatozoa before and after cryopreservation using comet assay*. Cryo Lett. 24, 171–180
- Harada, K. & Wolf, R.G. (1968). *Malic dehydrogenase. VII. The catalytic mechanism and possible role of identical protein subunits*. J. Biol. Chem. 243, 4131–4137
- Helma, C. & Uhl, M. (2000). *A public domain image-analysis program for the single-cell gel-electrophoresis (comet) assay*. Mutat. Res. 466, 9–15
- Homma-Takeda, S., Kugenuma, Y., Iwamuro, T., Kumagai, Y. & Shimojo, N. (2001). *Impairment of spermatogenesis in rats by methylmercury: involvement of stage- and cell-specific germ cell apoptosis*. Toxicology 169, 25–35
- Huang, S.Y., Kuo, Y.H., Lee, W.C., Tsou, H.L., Lee, Y.P., Chang, H.L., Wu, J.J. & Yang, P.C. (1999). *Substantial decrease of heat-shock protein 90 precedes the decline of sperm motility during cooling of boar spermatozoa*. Theriogenology 51, 1007–1016
- Huang, Z. & Vijayaraghavan, S. (2004). *Increased phosphorylation of a distinct subcellular pool of protein phosphatase, PP1gamma2, during epididymal sperm maturation*. Biol. Reprod. 70, 439–447
- Hughes, C.M., Lewis, S.E.M., McKelvey-Martin, V.J. & Thomson, W. (1997). *Reproducibility of human sperm DNA measurements using the alkaline single cell gel electrophoresis assay*. Mutat. Res. 374, 261–268
- Hwang, P.C. & Idler, D.R. (1969). *A major study on cations, osmotic pressure and pH in seminal components of Atlantic salmon*. J. Fish Res. Board Can. 26, 413–419
- Inaba, K., Kagami, O. & Ogawa, K. (1999). *Tctex2-related outer arm dynein light chain is phosphorylated at activation of sperm motility*. Biochem. Biophys. Res. Commun. 256, 177–183

- Inoue, K. & Takei, Y. (2003). *Asian medaka fishes offer new models for studying mechanisms of seawater adaptation*. Comp. Biochem. Physiol. B Biochem. Mol. Biol. 136, 635-645
- Johnson, L.A. & Ferris, J.A.J. (2002). *Analysis of postmortem DNA degradation by single-cell gel electrophoresis*. Forensic Sci. Int. 126, 43-47
- Kopeika, E., Kopeika, J. & Zhang, T. (2007). *Cryopreservation of fish sperm*. Methods Mol. Biol. 368, 203-217
- Kopeika, J., Kopeika, E., Zhang, T. & Rawson, D.M. (2003a). *Studies on the toxicity of dimethyl sulfoxide, ethylene glycol, methanol and glycerol to loach (Misgurnus fossilis) sperm and the effect on subsequent embryo development*. Cryo Letters 24, 365-374
- Kopeika, J., Kopeika, E., Zhang, T., Rawson, D.M. & Holt, W.V. (2004). *Effect of DNA repair inhibitor (3-aminobenzamide) on genetic stability of loach (Misgurnus fossilis) embryos derived from cryopreserved sperm*. Theriogenology 61,1661-1673
- Kopeika, J., Kopeika, E., Zhang, T., Rawson, D.M. & Holt, W.V. (2003b). *Detrimental effects of cryopreservation of loach (Misgurnus fossilis) sperm on subsequent embryo development are reversed by incubating fertilised eggs in caffeine*. Cryobiology 46, 43-52
- Krasznai, Z., Morisawa, M., Krasznai, Z.T., Morisawa, S., Inaba, K., Bazsane, Z.K., Rubovszky, B., Bodnar, B., Borsos, A. & Marian, T. (2003a). *Gadolinium, a mechano-sensitive channel blocker, inhibits osmosis-initiated motility of sea- and freshwater fish sperm but does not affect human or ascidian sperm motility*. Cell Motil Cytoskeleton 55, 232-243
- Krasznai, Z., Morisawa, M., Morisawa, S., Krasznai, Z.T., Tron, L. & Marian T. (2003b). *Role of ion channel and membrane potential in the initiation of carp sperm motility*. Aquat. Living. Resour. 16, 445-449
- Labbe, C., Martoriati, A., Devaux, A., & Maisse, G. (2001). *Effect of sperm cryopreservation on sperm DNA stability and progeny development in rainbow trout*. Mol. Reprod. Dev. 60, 397-404.
- Lahnsteiner, F., Berger, B., Wiesmann, T. & Patzner, R.A. (1996b). *Changes in morphology, physiology, metabolism, and fertilization capacity of rainbow trout semen following cryopreservation*. Prog. Fish. Cult. 58, 149-159
- Lahnsteiner, F., Weismann, T. & Patzner, R.A. (1992). *Fine structural changes in spermatozoa of the grayling, Thymallus thymallus (Pisces: Teleostei), during routine cryopreservation*. Aquaculture 103, 73-84
- Lahnsteiner, F., Berger, B., Horvath, A., Urbanyi, B. & Weismann, T. (2000). *Cryopreservation of spermatozoa in cyprinid fishes*. Theriogenology 54, 1477-1498
- Lahnsteiner, F., Berger, B., Weismann, T. & Patzner, R.A. (1996a) *Physiological and biochemical determination of rainbow trout, Onchorhynchus mykiss, semen quality for cryopreservation*. J. Appl. Aquacult. 6, 47-73
- Lahnsteiner, F., Patzner, R.A. & Weismann, T. (1994). *The spermatid duct of salmonid fishes. Fine structure, histochemistry and composition of the secretion*. J. Fish Biol. 42, 79-93
- Lahnsteiner, F., Weismann, T. & Patzner, R.A. (1998). *Evaluation of the semen quality of the rainbow trout, Onchorhynchus mykiss, by sperm motility, seminal plasma parameters, and spermatozoal metabolism*. Aquaculture 163, 163-181
- Larson, K.L., Brannian, J.D., Singh, N.P., Burbach, J.A., Jost, L.K., Hansen, K.P., Kreger, D.O. & Evenson, D.P. (2001). *Chromatin structure in globozoospermia: a case report*. J. Androl. 22, 424-431
- Latham, K.E. & Schultz, R.M. (2001). *Embryonic genome activation*. Front. Biosci. 6, 748-759
- Lessard, C., Parent, S., Leclerc, P., Bailey, J.L. & Sullivan, R. (2000). *Cryopreservation alters the levels of the bull sperm surface protein P25b*. J. Androl. 21, 700-707

- Lindemann, C.B. & Kanous, K.S. (1989). *Regulation of mammalian sperm motility*. Arch. Androl. 23, 1–22
- Lindemann, C.B. (1978). *A cAMP-induced increase in the motility of demembrated bull sperm models*. Cell 13, 9–18
- Linhart, O., Rodina, M. & Cosson, J. (2000). *Cryopreservation of sperm in common carp Cyprinus carpio: sperm motility and hatching success of embryos*. Cryobiology 41, 241–250
- Linhart, O., Walford, J., Sivaloganathan, B. & Lam, T.J. (1999). *Effects of osmolality and ions on the motility of stripped and testicular sperm of freshwater- and seawater-acclimated tilapia, Oreochromis mossambicus*. J. Fish Biol. 55, 1344–1358
- Luconi, M., Carloni, V., Marra, F., Ferruzzi, P., Forti, G. & Baldi, E. (2004). *Increased phosphorylation of AKAP by inhibition of phosphatidylinositol 3-kinase enhances human sperm motility through tail recruitment of protein kinase A*. J. Cell Sci. 117, 1235–1246
- Maldjian, A., Pizzi, F., Gliozzi, T., Cerolini, S., Penny, P. & Noble, R. (2005). *Changes in sperm quality and lipid composition during cryopreservation of boar semen*. Theriogenology 63, 411–421
- McConnell, E.J., Wagoner, M.J., Keenan, C.E. & Raess, B.U. (1999). *Inhibition of calmodulin-stimulated (Ca<sup>2+</sup>-Mg<sup>2+</sup>)-ATPase activity by dimethyl sulfoxide*. Biochem. Pharmacol. 57, 39–44
- McKelvey-Martin, V.J., Green, P., Schmezer, P., Pool-Zobel, B.L., DeMeo, M.P. & Collins, A. (1993). *The single cell gelelectrophoresis assay (comet assay): a European review*. Mutat. Res. 288, 47–63
- McLaughlin, E.A. & Ford, W.C.L. (1994). *Effects of cryopreservation on the intracellular calcium-concentration of human spermatozoa and its response to progesterone*. Mol. Reprod. Dev. 37, 241–246
- McNiven, M.A., Gallant, R.K. & Richardson, G.F. (1992). *In vitro methods of assessing the viability of rainbow trout spermatozoa*. Theriogenology 38, 679–686
- Moore, J.D., Kornbluth, S. & Hunt, T. (2002). *Identification of the nuclear localization signal in Xenopus cyclin E and analysis of its role in replication and mitosis*. Mol. Biol. Cell. 13, 4388–4400
- Morisawa, M. & Okuno, M. (1982). *Cyclic AMP induces maturation of trout sperm axoneme to initiate motility*. Nature 295, 703–704
- Morisawa, M. & Suzuki, K. (1980). *Osmolality and potassium ions: their roles in initiation of sperm motility in teleosts*. Science 210, 1145–1147
- Morisawa, M. (1994). *Cell signaling mechanisms for sperm motility*. Zool. Sci. 11, 647–662
- Morisawa, M., Suzuki, K., Shimizu, H., Morisawa, S. & Yasuda, K. (1983). *Effect of osmolality and potassium on motility of spermatozoa from freshwater cyprinid fishes*. J. Exp. Zool. 107, 95–103
- Müller, K., Müller, P., Pincemy, G., Kurz, A. & Labbe, C. (2008). *Characterization of sperm plasma membrane properties after cholesterol modification: consequences for cryopreservation of rainbow trout spermatozoa*. Biol. Reprod. 78, 390–399
- Nomura, M., Inaba, K. & Morisawa, M. (2000). *Cyclic AMP- and calmodulin-independent phosphorylation of 21- and 26-kDa proteins in axoneme is a prerequisite for SAAF-induced motile activation in ascidian spermatozoa*. Dev. Growth Differ. 42, 129–138
- Oda, A. & Morisawa, M. (1993). *Rises of intracellular Ca<sup>2+</sup> and pH mediate the initiation of sperm motility by hyperosmolality in marine teleosts*. Cell Motil. Cytoskeleton 25, 171–178
- Oda, S., Igarashi, Y., Manaka, K., Koibuchi, N., Sawada, M.S., Sasaki, K., Morisawa, M., Ohtake, H. & Shimizu, N. (1998). *Sperm-activating proteins obtained from the herring*



- eggs are homologous to trypsin inhibitors and synthesized in follicle cells. *Dev. Biol.* 41, 55–63
- Ogier de Baulny, B., Labbé, C. & Maisse G. (1999). *Membrane integrity, mitochondrial activity, ATP content, and motility of the European catfish (Silurus glanis) testicular spermatozoa after freezing with different cryoprotectants.* *Cryobiology* 39, 177–184
- Okamura, N., Tajima, Y., Soejima, A., Masuda, H. & Sugita, Y. (1985). *Sodium bicarbonate in seminal plasma stimulates the motility of mammalian spermatozoa through direct activation of adenylate cyclase.* *J. Biol. Chem.* 260, 9699–9705
- Opresko, L. & Brokaw, C.J. (1983). *cAMP-dependent phosphorylation associated with activation of motility of Ciona sperm flagella.* *Gamete Res.* 8, 201–218
- Ostling, O. & Johanson, K.J. (1984). *Microelectrophoretic study of radiation-induced DNA migration from individual cells.* *Biochem. Biophys. Res. Commun.* 123, 291–298
- Perez-Pe, R., Grasa, P., Fernandez-Juan, M., Peleato, M.L., Cebrian-Perez, J.A. & Muino-Blanco T. (2002). *Seminal plasma proteins reduce protein tyrosine phosphorylation in the plasma membrane of cold-shocked ram spermatozoa.* *Mol. Reprod. Dev.* 61, 226–233
- Piperakis, S.M., Visvardis, E.E. & Tassiou, A.M. (1999). *Comet assay for nuclear DNA damage.* *Methods Enzymol.* 300, 184–194
- Pollack, B.P., Kottenko, S.V., He, W., Izotova, L.S., Barnoski, B.L. & Pestka, S. (1999). *The human homologue of the yeast proteins Skb1 and Hsl7p interacts with Jak kinases and contains protein methyltransferase activity.* *J. Biol. Chem.* 274, 31531–31542
- Pommer, A.C., Rutllant, J. & Meyers, S.A. (2003). *Phosphorylation of protein tyrosine residues in fresh and cryopreserved stallion spermatozoa under capacitating conditions.* *Biol. Reprod.* 68, 1208–1214
- Rana, K.J. (1995). *Preservation of gametes.* In: N.R. Bromage and R.J. Roberts, Editors, *Broodstock Management and Eggs and Larval Quality*, Cambridge University Press, Cambridge, pp. 53–76
- Rawn, J.D. (1983). *Biochemistry.* Harper and Row, New York.
- Ritar, A.J. (1999). *Artificial insemination with cryopreserved semen from striped trumpeter (Latris lineata).* *Aquaculture* 180, 177–187
- Rodina, M., Gela, D., Kocour, M., Alavi, S.M., Hulak, M. & Linhart, O. (2007). *Cryopreservation of tench, Tinca tinca, sperm: sperm motility and hatching success of embryos.* *Theriogenology* 67, 931–940
- Ruggia, A., Gelpi, J.L., Busquets, M., Cascante, M. & Cortes, A. (2001). *Effect of several anions on the activity of mitochondrial malate dehydrogenase from pig heart.* *J. Mol. Catalysis B: Enzymatic* 11, 743–755
- Rurangwa, E., Volckaert, F.A.M., Huyskens, G., Kime, D.E. & Ollevier, F. (2001). *Quality control of refrigerated and cryopreserved semen using computer-assisted sperm analysis (CASA), viable staining and standardized fertilization in African catfish (Clarias gariepinus).* *Theriogenology* 55, 751–769
- Sakkas, D., Mariethoz, E., Manicardi, G., Bizzarro, D., Bianchi, P.G. & Bianchi, U. (1999). *Origin of DNA damage in ejaculated spermatozoa.* *Rev. Reprod.* 4, 31–37
- Shuyang, H., Jenkins-Keeran, K. & Curry Woods, L. (2004). *Activation of sperm motility in striped bass via a cAMP-independent pathway.* *Theriogenology* 61, 1487–1498
- Steele, E.K., McClure, N. & Lewis, S.E.M. (2000). *Comparison of the effects of two methods of cryopreservation on testicular sperm DNA.* *Fertil. Steril.* 74, 450–453
- Stephens, R.E. & Prior, G. (1992). *Dynein from serotonin-activated cilia and flagella: extraction characteristics and distinct sites for cAMP-dependent protein phosphorylation.* *J. Cell. Sci.* 103, 999–1012

- Stoss, J. (1983). *Fish gamete preservation and spermatozoa physiology*. In: Hoar WS, Randall DJ III, Donaldson EM (eds.), *Fish Physiology*. Academic Press, New York, pp. 305–350.
- Sun, J.G., Jurisicova, A. & Casper, R.F. (2000). *Detection of deoxyribonucleic acid fragmentation in human sperm: correlation with fertilization in vitro*. *J. Androl.* 21, 33–44
- Sun, Y., Clinkebeard, K.D., Clarke, C., Cudd, L., Highlander, S.K. & Dabo, S.M. (1999). *Pasteurella haemolytica leukotoxin induced apoptosis of bovine lymphocytes involves DNA fragmentation*. *Vet. Microbiol.* 65, 153–166
- Suquet, M.D., Dreanno, C., Fauvel, C., Cosson, J. & Billard, R. (2000). *Cryopreservation of sperm in marine fish*. *Aquacult. Res.* 31, 231–243
- Suquet, M.D., Dreanno, C., Petton, B., Normant, Y., Omnes, M.H. & Billard, R. (1998). *Long-term effects of the cryopreservation of turbot (*Psetta maxima*) spermatozoa*. *Aquat. Living Resour.* 11, 45–48
- Tash, J.S. & Bracho, G.E. (1994). *Regulation of sperm motility: emerging evidence for a major role for protein phosphatases*. *J. Androl.* 15, 505–509
- Tash, J.S. & Means, A.R. (1983) *Cyclic adenosine 30,50-monophosphate, calcium, and protein phosphorylation in flagellar motility*. *Biol. Reprod.* 28, 75–104
- Tiersch, T.R., Goudie, C.A. & Carmichael, G.J. (1994). *Cryopreservation of channel catfish sperm: storage in cryoprotectants, fertilization trials, and growth of channel catfish produced with cryopreserved sperm*. *Trans. Am. Fish Soc.* 123, 580–586
- Vijayaraghavan, S., Goueli, S.A., Davey, M.P. & Carr, D.W. (1997a). *Protein kinase Anchoring inhibitor peptides arrest mammalian sperm motility*. *J. Biol. Chem.* 272, 4747–4752
- Vijayaraghavan, S., Trautman, K.D., Goueli, S.A. & Carr, D.W. (1997b). *A tyrosinephosphorylated 55-kilodalton motility-associated bovine sperm protein is regulated by cyclic adenosine 30,50-monophosphates and calcium*. *Biol. Reprod.* 56, 1450–1457
- Wood, D.C., Jurgensen, R.J., Geesin, C. & Harrison, J.H. (1981). *Subunit interactions in mitochondrial malate dehydrogenase. Kinetics and mechanism of reassociation*. *J. Biol. Chem.* 256, 2377–2382
- Yanagimachi, R., Cherr, G.N., Pillard, M.C. & Baldwin, J.D. (1992). *Factors controlling sperm entry into the micropyles of salmonid and herring eggs*. *Dev. Growth Differ.* 34, 447–461
- Zhang, Y.Z., Zhang, S.C., Liu, X.Z., Xu, Y.Y., Wang, C.L.M., Sawant, S., Li, J. & Chen, S. L. (2003). *Cryopreservation of flounder (*Parabchthys olivaceus*) sperm with a practical methodology*. *Theriogenology* 60, 989–996
- Zilli, L., Schiavone, R., Storelli, C. & Vilella S. (2008a). *Molecular mechanisms determining sperm motility initiation in two sparids (*Sparus aurata* and *Lithognathus mormyrus*)*. *Biol. Reprod.* 79, 356–366
- Zilli, L., Schiavone, R., Storelli, C. & Vilella, S. (2008b). *Effect of cryopreservation on phosphorylation state of proteins involved in sperm motility initiation in sea bream*. *Cryobiology* 57, 150–155
- Zilli, L., Schiavone, R., Zonno, V., Rossano, R., Storelli, C. & Vilella S. (2005). *Effect of cryopreservation on sea bass sperm proteins*. *Biol. Reprod.* 72, 1262–1267
- Zilli, L., Schiavone, R., Zonno, V., Storelli, C. & Vilella, S. (2003). *Evaluation of DNA damage in *Dicentrarchus labrax* sperm following cryopreservation*. *Cryobiology* 47, 227–235
- Zilli, L., Schiavone, R., Zonno, V., Storelli, C. & Vilella, S. (2004). *ATP concentration and  $\beta$ -D-glucuronidase activity as indicators of sea bass semen quality*. *Biol. Reprod.* 70, 1679–1684

## **Part 7**

# **Cryopreservation of Plants**



## Current Issues in Plant Cryopreservation

Anja Kaczmarczyk<sup>1,2</sup>, Bryn Funnekotter<sup>1,2</sup>, Akshay Menon<sup>1,2</sup>,  
Pui Ye Phang<sup>1,2</sup>, Arwa Al-Hanbali<sup>1,2</sup>, Eric Bunn<sup>2,3</sup> and Ricardo L. Mancera<sup>1</sup>

<sup>1</sup>*Curtin Health Innovation Research Institute, Western Australian Biomedical Research  
Institute, Curtin University, Perth*

<sup>2</sup>*Botanic Gardens and Parks Authority, Fraser Avenue, West Perth*

<sup>3</sup>*School of Plant Biology, Faculty of Natural and Agricultural Sciences,  
University of Western Australia  
Australia*

### 1. Introduction

Plant cryopreservation involves the storage of plant tissues (usually seed or shoot tips) in liquid nitrogen (LN) at  $-196^{\circ}\text{C}$  or in the vapour phase of LN at  $-135^{\circ}\text{C}$  in such a way that the viability of stored tissues is retained following re-warming (Day et al., 2008; Hamilton et al., 2009). Cryopreservation is usually applied to species with recalcitrant (i.e. dehydration sensitive) seeds that are not storable by any other means, or preservation of specific cultivars of vegetatively propagated crop plants like banana or potato, or for unique ornamental genotypes (Halmagyi et al., 2004; Kaczmarczyk et al., 2011a; Panis et al., 2005). Another reason to utilise cryostorage is to conserve endangered plant species, particularly where seeds may be extremely scarce or of doubtful quality and/or the species is threatened with imminent extinction (Decruse et al., 1999; Mallon et al., 2008; Mandal & Dixit-Sharma, 2007; Paunescu, 2009; Sen-Rong & Ming-Hua, 2009; Touchell et al., 2002).

The main advantage of cryopreservation is that once material has been successfully cooled to LN temperatures, it can be conserved in principle indefinitely, because at these ultra-low temperatures no metabolic processes occur. Replenishing a small volume of LN weekly in cryo-dewars is the only on-going maintenance operation usually required in cryostorage. There are further advantages to this approach: the low costs of storage, minimal space requirements and reduced labour maintenance compared to living collections and even when compared to maintenance of tissue cultures at room temperature. Once in storage, there is no risk of new contamination by fungus or bacteria, and cryogenically stored material has been reported to retain genetic stability (Harding, 2004). Depending on the species, small cryopreserved samples may take several weeks to re-establish shoot cultures, and several months to a year may be required to produce micropropagated plants capable of transfer to soil under greenhouse conditions and (following weaning) into the field.

Shoot tips (containing the apical meristem) are the most commonly used plant material for cryostorage. The apical meristem is composed of small unvacuolated cells served with a relatively small vascular system. The organised structure of apical meristems generally results in direct shoot formation after re-warming, thereby maintaining the genetic integrity

of the resulting propagated material. While callus tissue (unorganised wound tissue) can also be cryostored, the risk of occurrence of genetic deviations may be higher when utilising the indirect organogenesis pathway. Besides shoot tips, callus cultures, cell cultures, somatic embryos, pollen or plant buds as well as recalcitrant and orthodox seeds can be used as explants in plant cryopreservation (Reed, 2008).

Plant cryopreservation began with research on the freezing of mulberry twigs in LN (Sakai, 1965). Since then, a huge variety of plants and genotypes have been successfully cryostored for conservation of agriculture and horticultural genotypes, as well as for endangered and threatened plant species (Gonzalez-Arno et al., 2008; Hamilton et al., 2009; Kaczmarczyk et al., 2011b; Mycock et al., 1995; Reed, 2008; Sakai & Engelmann, 2007). This chapter reviews and gives examples of different plant cryopreservation protocols that have been successfully applied. It will focus on free radical damage and membrane structure, both important topics in the cryopreservation of biological tissues. The topic of genetic and epigenetic stability in plant cryopreservation is also discussed. Recent reviews of plant cryopreservation have been written by Benson (2008), Day & Stacey (2007), Hamilton et al. (2009) and Reed (2008).

## **2. Plant cryopreservation methods**

In the last three decades a number of different cryopreservation protocols, such as classical slow-cooling, vitrification, droplet vitrification, encapsulation/dehydration and encapsulation/vitrification protocols have been developed and utilised for germplasm storage (Reed, 2008). The choice of cryopreservation method to attain the highest survival rates is largely dependent on the plant species and tissue type that is being cryostored.

### **2.1 Slow cooling or controlled rate cooling**

This technique involves the simple dehydration of plant material before cryogenic storage in LN. This can be done by slow cooling of the plant tissue to a temperature of approximately  $-40^{\circ}\text{C}$  (Reinoud et al., 2000). This forces the formation of extracellular ice ahead of intracellular ice, thus causing an outflow of water from the cells due to the resulting osmotic imbalance and, consequently, dehydration. Dehydration can also be brought about by incubation of tissue material on media containing a relatively high concentration of an osmoregulant, commonly sucrose, although other compounds can also be used (Panis et al., 2002). Usually water concentrations must be decreased to between 10% and 20% of the fresh weight for optimal cryogenic survival (Engelmann, 2004). This has the aforementioned effects of reducing the extent of ice crystal formation due to the reduced water concentration and assisting in the achievement of the vitrified state of water as a result of the increased solute concentration. These techniques do not necessarily make use of cryoprotective agents (CPAs), however they can be used in conjunction with them to further improve dehydration (Reinoud et al., 2000), though these agents can be toxic to plant cells at high concentrations (Arakawa et al., 1990). Rapid re-warming rates are used after cryogenic storage to prevent ice crystal formation during thawing (Reinoud et al., 2000). This approach can result in extreme rates of dehydration, which can cause cell volume reductions that are potentially lethal (Day et al., 2008). It has been suggested that slow-cooling is only suitable for non-organised tissues, as sufficient dehydration is more difficult to achieve in tissues with complex structures due to the different rates of water movement between and within plant cells with different characteristics (Gonzalez-Arno et al., 2008).

## 2.2 Encapsulation-dehydration

This method, developed by Fabre and Dereuddre (1990), involves encapsulating shoot tips, somatic embryos or callus cells within alginate beads. This is followed by incubation in media with high sugar concentrations in order to raise intracellular solute concentrations and promote desiccation. Finally, silica gel or airflow is used to dehydrate the beads until the moisture content drops to 20-30%, before they are immersed in LN (Fabre & Dereuddre, 1990; Hamilton et al., 2009; Reinhoud et al., 2000). The encapsulating material is thought to promote a vitrified state in the tissue regardless of the cooling and re-warming rates, thus reducing damage from ice crystal formation (Scottez et al., 1992). Mechanical stress is also reduced because the bead protects the explants from damage during handling. The benefits of this method include avoiding the use of high concentrations of (potentially toxic) CPAs (Reinhoud et al., 2000) and the presence of a nutritive bead, which may enhance post-regeneration survival or re-growth of the material following immersion in LN and re-warming (Panis & Lambardi, 2005).

## 2.3 Vitrification

Vitrification involves the treatment of tissues in a mixture of highly concentrated penetrating and non-penetrating CPAs applied at non-freezing temperatures, followed by rapid cooling in LN (Gonzalez-Arno et al., 2008; Panis & Lambardi, 2005). The combination of high intracellular solute concentrations (due to dehydration and some CPA penetration) and rapid cooling prevents the nucleation of water and the formation of ice crystals, both intracellularly and extracellularly, thus promoting the vitrification of water (Kreck et al., 2011; Mandumpal et al., 2011; Reinhoud et al., 2000).

For plants sensitive to direct exposure to vitrification solutions, due to dehydration intolerance and osmotic stresses, a loading step of 10-20 minutes can be incorporated prior to incubation within the CPA solution. This is done by incubation of the samples within a less toxic/concentrated CPA solution (a media containing 0.4 M sucrose and 2 M glycerol proved highly effective [Nishizawa et al., 1993; Sakai et al., 1990]), thereby improving dehydration tolerance. The CPAs used in vitrification usually contain high concentrations of glycerol, dimethyl sulfoxide (DMSO), ethylene glycol and various sugars (Day et al., 2008). The most commonly used mixture of CPAs for vitrification is plant vitrification solution 2 (PVS2), which consists of 30% (w/v) glycerol, 15% (w/v) ethylene glycol and 15% (w/v) DMSO in basal culture medium containing 0.4 M sucrose (Sakai et al., 1990, 2008).

Exposure time to cryoprotective solutions is a vital step in the cryostorage process. Volk and Walters (2006) demonstrated that the extent of penetration of PVS2 into mint and garlic shoot tips was directly proportional to exposure time. The water content of the shoot tips also significantly decreased with an increase in exposure time to PVS2 (Volk & Walters, 2006). Greater penetration of CPAs can be useful as it helps to increase the internal solute concentration and may contribute to maintaining cell volume, thus preventing damage to the cells (Meryman, 1974). However, overexposure to CPAs may cause damage to the cells owing to the toxic nature of the CPAs or excessive dehydration.

The vitrification protocol is a more widely applied cryopreservation method than slow cooling due to its ease of use, high reproducibility and the wide range of species with complex tissue

structure (such as shoot tips and embryos) that have been successfully cryopreserved with this procedure (Takagi et al., 1997; Touchell et al., 1992; Vidal et al., 2005).

## 2.4 Droplet-vitrification

The droplet-vitrification technique is a modification of the basic vitrification protocol that involves placing the sample within a droplet of 1-10  $\mu\text{L}$  of cryoprotective solution on a piece of aluminium foil before immersion in LN (as opposed to 1-2 mL of cryoprotective solution in the original protocol), as shown in Fig. 1.

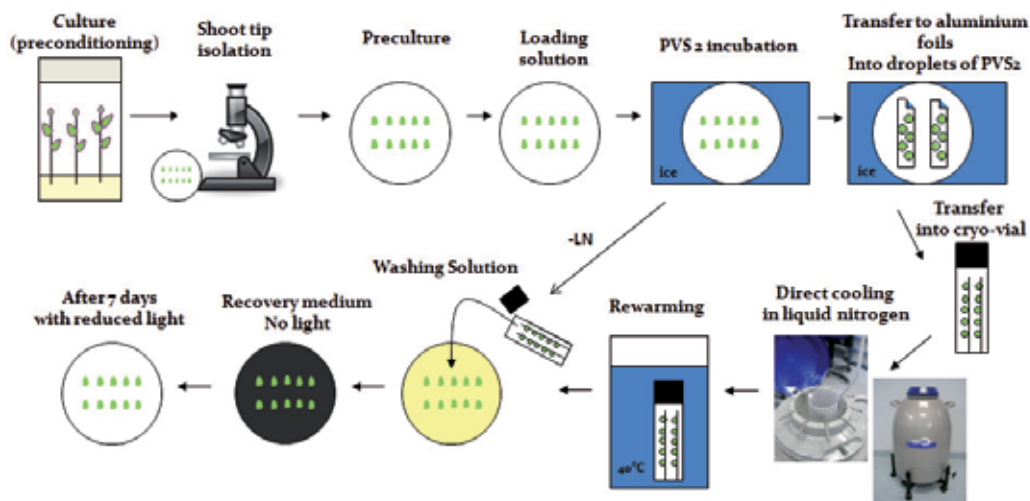

Fig. 1. Cryopreservation procedure for the droplet vitrification method.

This approach achieves higher cooling and re-warming rates, as the small volume of liquid allows a higher rate of heat transfer to and from the sample (Sakai & Engelmann, 2007). Cooling rates are increased to  $>130^{\circ}\text{C}/\text{sec}$  (Panis & Lambardi, 2005), therefore facilitating the direct transition of intracellular water from a liquid state to a glassy state far more rapidly, thus minimising water crystallisation. The droplet-vitrification protocol has been successfully applied in the cryopreservation of garlic and chrysanthemum (Kim et al., 2009), yams (Leunufna & Keller, 2005), lily (Chen et al., 2011), potato (Yoon et al., 2006) and other plants (Sakai & Engelmann, 2007).

## 2.5 Encapsulation-vitrification

Another modification of the vitrification approach termed encapsulation/vitrification combines elements of the encapsulation/dehydration method with the vitrification method. As with the standard encapsulation method, shoot tips or calluses are first encapsulated in alginate beads and then the encapsulated material is incubated in a vitrification solution to promote sufficient dehydration and vitrification rather than dehydration under a constant airflow, which is very time consuming and relatively imprecise (Hirai & Sakai, 1999). Successful protocols have been established for potato (Hirai & Sakai, 1999), gentian (Tanaka et al., 2004), strawberry (Hirai et al., 1998) and pineapple (Gamez-Pastrana et al., 2004).



### 3. Free radical and oxidative damage in plant cryopreservation

While achieving an optimum cryopreservation protocol that successfully avoids ice damage is important, there are various other factors that can affect post-cryogenic survival (Fig. 2). During the cryopreservation procedure plant tissues are susceptible to a variety of stresses, including oxidative stresses (Benson & Bremner, 2004).

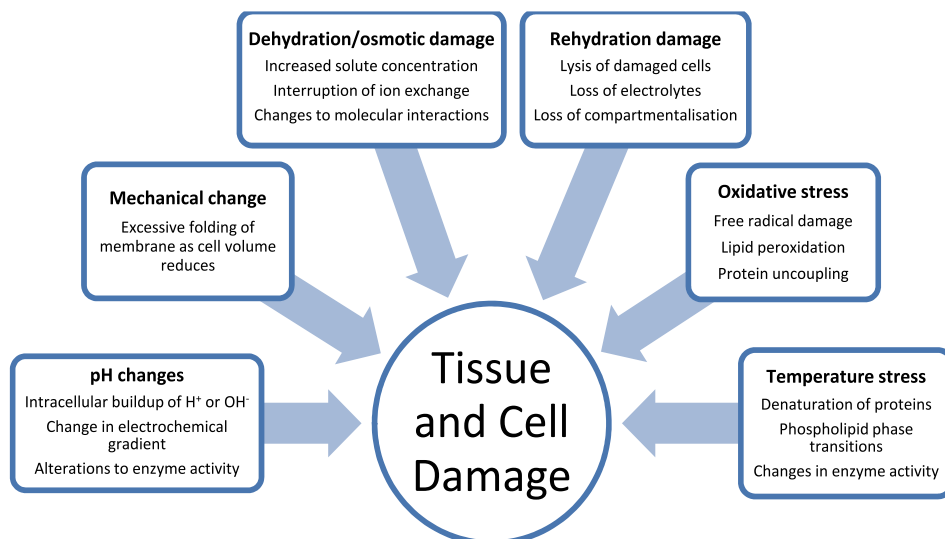

Fig. 2. Main causes of damage to plant tissues during cooling and cryopreservation (modified from [Turner, 2001]).

#### 3.1 Reactive oxygen species (ROS)

The formation of reactive oxygen species (ROS) during cryopreservation can occur during the many steps involved in this process. For example, ROS formation has been detected in photo-oxidative stress during tissue culture, during excision of shoot apices, osmotic injury and desiccation following application of CPAs, as well as during the rapid changes in temperature when the samples are first cryostored in LN and then re-warmed (Benson & Bremner, 2004; Roach et al., 2008). ROS are highly reactive molecules that can cause a wide range of damage in cells. There is a large variety of molecules that are classified as ROS, some of which include oxygen-free radical species and reactive oxygen non-radical derivatives (Table 1).

Radicals	Non-Radicals
Superoxide ( $O_2^{\bullet-}$ )	Hydrogen peroxide ( $H_2O_2$ )
Hydroxyl ( $OH^{\bullet}$ )	Peroxynitrite ( $ONOO^-$ )
Hydroperoxyl ( $OOH^{\bullet}$ )	Peroxynitrous acid ( $ONOOH$ )
Peroxyl ( $ROO^{\bullet}$ )	Hypochlorous acid ( $HOCl$ )
Alkoxy ( $RO^{\bullet}$ )	Hypobromous acid ( $HOBr$ )
Carbonate ( $CO_3^{\bullet-}$ )	Ozone ( $O_3$ )
Carbon dioxide ( $CO_2^{\bullet-}$ )	Singlet oxygen ( $^1\Delta g$ )
Singlet oxygen ( $^1\Sigma g^+$ )	

Table 1. Common reactive oxygen species (ROS) (Halliwell & Gutteridge, 2007).

Many of the more active ROS are free radicals, which are molecules that contain an unpaired electron, thus being able to react non-specifically with neighbouring molecules by removing electrons and causing a self-propagating chain reaction of radical formation. The removal of electrons can lead to a loss of function and structural alterations in macromolecules like proteins, lipids and DNA (Benson, 1990; Halliwell & Gutteridge, 2007). ROS are frequently produced as by-products during cellular metabolism. The electron transport chain used in respiration and photosynthesis are the major producers of ROS, caused by the leakage of free electrons onto molecular oxygen (O<sub>2</sub>), resulting in the formation of superoxide (Benson & Bremner, 2004; Benson, 1990; Halliwell & Gutteridge, 2007). The formation of ROS is controlled by a high concentration of antioxidants and proteins that can quench the ROS and fix the damage in these regions. Nevertheless, if there is a sudden increase in ROS formation then cellular repair processes can be overwhelmed and excessive damage can occur.

Temporarily reducing cryo-sample exposure to light immediately after cryopreservation has been shown to increase post-cryogenic survival due to the removal of photo-oxidative stress in the plants (Senula et al., 2007; Touchell et al., 2002). Photo-oxidative stress in plants can result in high levels of singlet oxygen (<sup>1</sup>Σg<sup>+</sup>) and superoxide (O<sub>2</sub><sup>•-</sup>) being produced, either from direct UV radiation on oxygen or the leakage of light energy onto oxygen from chlorophyll when the carotenoid pigments become saturated (Wise, 1995). Plants are highly susceptible to photo-oxidative stresses at low temperatures when exposed to strong light conditions. This can be demonstrated in alpine plants, many of which display adaptations (especially to leaves, i.e. the production of carotenoid pigments) that reduce photo-oxidation damage from enhanced UV-B radiation at high altitudes (Streb et al., 1998). When the ability of antioxidants to quench the formation of ROS and the recycling of antioxidants is reduced, greater damage occurs to the chloroplast through lipid peroxidation, inactivation of photosynthetic proteins and loss of pigments (i.e. bleaching) (Wise, 1995; Wise & Naylor, 1987). Damage to the chloroplast during chilling stress has been shown to severely impede growth rates (Partelli et al., 2009); therefore, reducing the damage that occurs to plant cells due to low temperature oxidative stress is vitally important for improving survival and recovery in cryopreservation.

The most reactive ROS commonly found in plants include superoxide (O<sub>2</sub><sup>•-</sup>), the hydroxyl radical (OH<sup>•</sup>), hydroperoxyl (OOH<sup>•</sup>) and singlet oxygen (<sup>1</sup>Σg<sup>+</sup>). Superoxide and singlet oxygen are often formed as by-products of the electron transport chain from both metabolism and photosynthesis, while hydroperoxyl and hydroxyl radicals are commonly formed in a process called Fenton's reaction, where hydrogen peroxide is converted into the hydroxyl or hydroperoxyl radical (1).

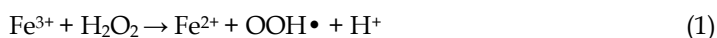

The formation of the hydroxyl radical is the major cause of lipid peroxidation in membranes, but can also cause a wide range of damage to all cellular components, including proteins and DNA (Halliwell & Gutteridge, 2007). The addition of specific chelating agents (such as desferrioxamine) has been shown to reduce the levels of iron in cryopreserved tissues, with subsequent decreased levels of the hydroxyl radical observed (Benson et al., 1995; Fleck et al., 2000; Obert et al., 2005).

Damage caused by ROS is difficult to quantify as these molecules are non-specific in their interactions, reacting freely with lipids, proteins and DNA. ROS are highly reactive (and

therefore short-lived) and thus, direct measurement of the ROS present in cells is difficult due to time constraints, and does not reflect the damage that may be done prior to the ROS being quenched by antioxidants. Consequently, it is easier to measure the formation of by-products of oxidative damage or the antioxidant status of the cells. The ratio of oxidised to reduced antioxidants is a good indication of ROS formation and the ability of cells to regulate oxidative stress. Identifying end products of ROS oxidation is an indication of the damage caused and is a sign that cells have been unable to satisfactorily quench ROS activity.

### 3.2 Lipid peroxidation

The cell membrane represents one of the major areas where cryo-injury can occur. Any damage to the cell membrane can alter the delicate balance between intra and extracellular solutes, leading to cell death (Anchordoguy et al., 1987; Dowgert & Steponkus, 1984; Gordon-Kamm & Steponkus, 1984; Lynch & Steponkus, 1987). Lipid peroxidation of fatty acids (FA) in phospholipids can cause extensive damage to the cell membrane if the chain reaction is not controlled, leading to large areas where the semi-permeability of the membrane is altered and thus can no longer function normally (Benson et al., 1992; Halliwell & Gutteridge, 2007). Lipid peroxidation is caused when specific ROS (hydroxyl radical, peroxy radical and singlet oxygen) interact with a FA. Polyunsaturated fatty acids (PUFA) are the most susceptible to peroxidation (Møller et al., 2007; Young & McEneny, 2001). Glutathione peroxidase can detoxify lipid peroxides by reducing them back to their lipid alcohol form and, in the process, oxidising glutathione (Benson, 1990). The formation of the toxic end-products of lipid peroxidation, such as malondialdehyde (MDA) and 4-hydroxynonenal (HNE), can also cause damage to cells (Halliwell & Gutteridge, 2007). The toxicity of MDA is debatable (Halliwell & Gutteridge, 2007); however, there is evidence that MDA can interact with proteins and DNA, causing loss of function in proteins and mutations in DNA (Halliwell & Gutteridge, 2007; Hipkiss et al., 1997; Marnett, 1999). The formation of HNE has shown greater toxicity to cells as it can damage mitochondria, inhibit synthesis of DNA and proteins, and interfere with the action of repair proteins such as chaperones (Halliwell & Gutteridge, 2007). Identifying the formation of MDA and HNE is commonly used in cryopreservation as an indicator of oxidative stress. High levels of MDA or HNE detected have correlated with decreased survival rates in rice cell suspensions, olive somatic embryos, flax and blackberry shoot tips (Benson et al., 1992; Obert et al., 2005; Uchendu et al., 2010; Lynch et al., 2011).

Volatile headspace sampling (VHS) measures the formation of volatile compounds released from a sample in a non-destructive and non-invasive assay method. This provides an important tool for measuring oxidative stress. Free radical damage can cause the formation of volatile compounds such as methane, ethane, ethylene and pentane. Quantification of these compounds can be indicative of oxidative damage. The detection of ethylene in plants is of particular importance as ethylene is a vital hormone. Fang et al. (2008) observed that decreased levels of ethylene production correlated with decreased survival and growth. The production of the other volatile compounds is indicative of lipid peroxidation, where increased levels correlate to excessive oxidative damage. Benson et al. (1987) observed a large increase in volatile compounds produced after thawing that has since been observed in other species.

The use of DMSO as a free radical scavenger and probe for the hydroxyl radical can be utilised with VHS. The formation of methane when DMSO interacts with the hydroxyl radical can be measured if the sample is placed in an airtight container, with the levels of methane detected correlating with the formation of the hydroxyl radical. This technique has been used as a measurement of oxidative stress in multiple different plant species, such as rice, cocoa, *Daucus carota* and flax (Benson & Withers 1987; Benson et al., 1995; Obert et al., 2005; Fang et al., 2008). The production of methane is particularly strong during the initial phase of recovery, where it is predicted that antioxidant activity and production is reduced, resulting in increased ROS (Fang et al., 2008). The use of chelating agents to reduce the formation of hydroxyl radicals from the Fenton reaction has shown significant benefits in plant cryopreservation. Desferrioxamine is the most common chelating agent used. It binds to and reduces the amount of free iron. The addition of desferrioxamine to rice cells during cryopreservation showed a decreased recovery period after cryopreservation (Benson et al., 1995). Detection of methane formation was delayed in flax tissue when exposed to desferrioxamine (Obert et al., 2005), indicating a delayed production of hydroxyl radicals.

### 3.3 Antioxidants

An antioxidant can be defined as any molecule that “delays, prevents or removes oxidative damage to a target molecule” (Halliwell & Gutteridge, 2007). Antioxidants can be classified into two major groups: enzymes that catalytically remove ROS, or sacrificial antioxidant molecules that are preferentially oxidised to protect more important molecules by quenching ROS (Halliwell & Gutteridge, 2007). The addition of exogenous antioxidants during cryopreservation has been shown to result in increased survival in some cases (Uchendu et al., 2010; Wang & Deng, 2004). It is possible that the addition of exogenous antioxidants may also aid in reducing oxidative stresses immediately following re-warming, when cellular metabolism has not been restored to its original state.

Glutathione (GSH) is one of the main water soluble sacrificial antioxidants in plants (Kranmer et al., 2006). This low molecular weight thiol is converted to its oxidised form (GSSG) upon interaction with ROS. The ratio of reduced to oxidised GSH is a good indicator of oxidative stress, as an increased amount of GSSG indicates the inability of the plant to control oxidative damage, thereby triggering premature cell death (Kranmer et al., 2006). GSH is recycled by the enzyme GSH reductase using NADPH as the electron donor (Halliwell & Gutteridge, 2007). Ascorbic acid is the most abundant water-soluble antioxidant in plant cells (Foyer & Noctor, 2009). This antioxidant is able to quench free radicals, forming the stable radical semidehydroascorbate, which can be further oxidised to dehydroascorbate by another free radical. *Arabidopsis* mutants, which were unable to express ascorbic acid activity, demonstrated the important role this antioxidant plays in reducing oxidative stress, as these plants were not viable following exposure to photo-oxidative stress (Dowdle et al., 2007). Tocopherol (Vitamin E) is a lipophilic antioxidant. This is the main antioxidant involved in membrane protection against lipid peroxidation, as it is preferentially oxidised instead of PUFAs (Halliwell & Gutteridge, 2007; Uchendu et al., 2010). This antioxidant is thought to be reduced to its original, functional state by ascorbic acid (Packer et al., 1979). Carotenoid pigments are the main defence in chloroplasts, where large amounts of singlet oxygen can be produced if the activated chlorophylls transfer their energy onto oxygen. The carotenoid pigments can absorb the energy directly from the

chlorophylls, thus suppressing the formation of singlet oxygen, and they can also quench the singlet oxygen directly (Halliwell & Gutteridge, 2007).

The enzyme superoxide dismutase (SOD) catalytically removes the ROS superoxide, producing oxygen and hydrogen peroxide. The removal of superoxide is more important than the formation of hydrogen peroxide, as superoxide is a more reactive species, causing wider damage in the cells. There is potential for SOD to cause formation of ROS if levels of hydrogen peroxide are not controlled. SOD contains a metal cofactor that can cause Fenton reactions and the formation of the hydroxyl radical. Catalase is the main enzyme involved in removing hydrogen peroxide, resulting in the decomposition of hydrogen peroxide to water and oxygen. This enzyme is vital for the removal of hydrogen peroxide before it can damage the cell or be converted to the highly reactive hydroxyl radical through Fenton's reaction.

#### 4. Plant cryopreservation and membrane structure

Membrane systems within cells are usually the site of freezing injury in plants (Steponkus, 1984). Membrane stability is therefore important for reducing such injury. There are four types of injury: (i) expansion-induced lysis, where the cells overexpand as a result of increased extracellular osmotic pressure during warming/thawing; (ii) loss of osmotic responsiveness, where there is no osmotic change during warming due to a slow cooling rate (cells remain dehydrated); (iii) altered osmotic behaviour, where cells membranes turn "leaky", resulting in the release of water and solutes into the surroundings; and (iv) intracellular ice formation, where rapid cooling causes membrane disruption due to the formation of ice crystals (Steponkus, 1984).

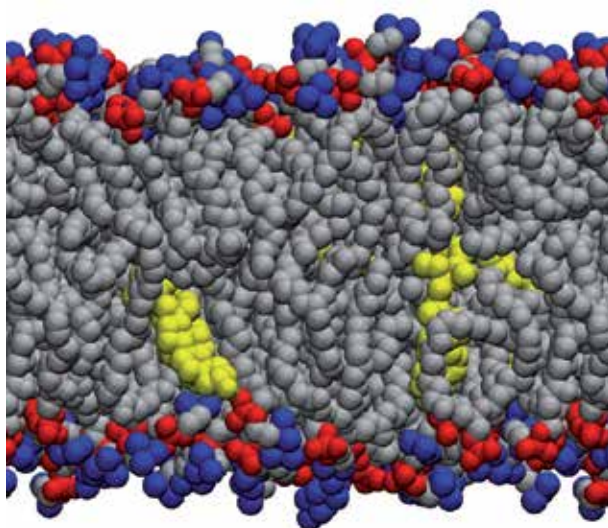

Fig. 3. Typical cell membrane structure consisting of a phospholipid bilayer with embedded sterols. Phospholipid chains are shown in grey, choline groups in blue and phosphate groups in red, while sterol molecules are shown in yellow.

The cell membrane is a bilayer consisting of different lipids and associated proteins (Fig. 3), where the lipids define the cell membrane structure and fluidity, and have a function in

signal transduction (Foubert et al., 2007; Furt et al., 2011). The three main classes of lipids found in cell membranes are glycerolipids (mostly phospholipids), sterols and sphingolipids (Furt et al., 2011).

#### 4.1 Phospholipids

Phospholipids are amphiphilic molecules that form the core structure of the cell membrane lipid bilayer. They consist of a polar head (containing a phosphate group and simple organic molecule) and a (mostly) non-polar fatty acid tail. The most common phospholipid components of membranes include phosphatidylcholine (PC), phosphatidylethanolamine (PE), phosphatidylglycerol (PG), phosphatidylinositol (PI), phosphatidylserine (PS) and phosphatidic acid (PA). Phospholipids essentially maintain the structure, fluidity and permeability of the membrane, determined to some extent by the type of phospholipid present and the level of unsaturation in their fatty acid tails (Emmelot & Vanhoeven, 1975; van Meer et al., 2008).

#### 4.2 Sterols

Sterols are steroid alcohols that are integral components of living cells. They are formed as intermediate molecules during the metabolic production of hormones and are an integral component of cell membranes (Hartmann, 1998; Hodzic et al., 2008). Sterols are non-polar molecules with a polar hydroxyl (-OH) side chain that allows them to interact with the polar and non-polar groups of the phospholipid bilayer. They restrict the motion of the fatty acid chains in phospholipids, thus controlling the fluidity of the cell membrane (Hartmann, 1998). The major plant sterols are cholesterol, campesterol, sitosterol and stigmasterol (Grunwald, 1975). Sitosterol is usually found in higher concentration in apex tissue than stigmasterol (Grunwald & Saunders, 1978). The composition and concentration of these sterols within the membrane modify its permeability and fluidity (Grunwald, 1975; Grunwald & Saunders, 1978; Nes, 1974). Cholesterol has the greatest stabilising effect on membranes due to its small side chain (Grunwald & Saunders, 1978).

The ability of sterols to alter stability and permeability of membranes can have a large effect on post-cryopreservation survival of plant tissue. The ratio of stigmasterol to sitosterol has been found to increase after sucrose preculture and was unfavourable to obtaining high percentages of shoot regeneration after cryopreservation of banana meristems (Zhu et al., 2006). Marsan et al. (1998) investigated the interactions of sitosterol and stigmasterol with phosphatidylcholine molecules in soybean and discovered, using neutron scattering experiments, that sitosterol has a greater effect than stigmasterol on the ordering of the fatty acyl chains of PC and increasing the hydrophobic thickness of PC bilayers. Cold acclimation of winter rye (*Secale cereale*) seedlings showed an increase in free sterol content, with  $\beta$ -sitosterol having the largest increase (Lynch & Steponkus, 1987). Uemura and Steponkus (1994) also found an increase of  $\beta$ -sitosterol with cold acclimation in winter rye; however, these results were not mimicked in spring oats (*Avena sativa* L. cv Ogle), where there was no significant change in  $\beta$ -sitosterol, but the stigmasterol proportion increased, whilst cholesterol decreased.

#### 4.3 Soluble sugars

Intracellular soluble sugars and sugar alcohols, such as the ones used in preculture media, reduce damage sustained by cell membranes when the cells undergo desiccation and can

improve membrane stability (Crowe et al., 1988; Steponkus, 1984). Smaller sugar molecules help membranes to osmotically retain water and may enter the interlamellar space to maintain a degree of hydration and increase the separation between membranes, thus reducing compressive stresses and, consequently, reducing the chance of a fluid-gel phase transition (Wolfe & Bryant, 1999). Furthermore, the polar hydroxyl (-OH) groups on sugars and sugar alcohols have been thought to interact with the polar membrane phospholipid headgroups and stabilise the membranes by maintaining the separation of the phospholipid molecules (Steponkus, 1984; Turner et al., 2001; Wolfe & Bryant, 1999). Turner et al. (2001) tested several sugars and sugar polyalcohols and determined that the small size of molecules such as glycerol and erythritol allowed them to 'pack' around membranes and have better bonding abilities. Additionally, the stereochemical arrangement of the -OH groups, particularly their orientation along one side of the molecules, imparted more stable hydrogen bonds with the membrane phospholipids and, consequently, resulted in more stable membranes (Turner et al., 2001). Nonetheless, recent biophysical studies have established that specific interactions of sugar molecules to phospholipid headgroups are not necessary to explain the stabilising effect of sugars on membrane gel to fluid transition temperatures (Lenne et al. 2006, 2007, 2009) and that sugars do not in fact insert between phospholipid headgroups but instead a solvation layer of water molecules separates them from the phospholipid headgroups (Kent et al., 2010).

#### 4.4 Preconditioning and cold acclimation

Cold acclimation is the process in which plants being exposed to low non-freezing temperatures increase their freezing tolerance (Thomashow, 1999; Sakai & Engelmann, 2007). Preconditioning of raspberry and blueberry plants at 22/-1°C alternating temperatures for four weeks was essential for optimal post-cryopreservation shoot-tip regrowth using encapsulation-dehydration and vitrification protocols (Gupta & Reed, 2006). Similarly, better recovery rates were seen in mint (Senula et al., 2007) and yams (Leunufna & Keller, 2005) when they were cold acclimated for several weeks before cryostorage.

Cold acclimation is thought to activate genes that improve plant survival at low temperatures by improving stability in membranes (Guy et al., 1985; Thomashow, 1999). Cell membrane phospholipids and sterols have been observed to increase in proportion upon cold acclimation in winter rye, with a particular increase in di-unsaturated PC and  $\beta$ -sitosterol (Uemura & Steponkus, 1994). Changes in phospholipid and sterol composition were found in *Arabidopsis thaliana* after cold acclimation at 2°C for one week, which increased its freezing tolerance from -2°C down to -10°C (Uemura et al., 1995). Cell membrane phospholipid changes were also observed in oat leaves (Uemura & Steponkus, 1994). These changes may be related to improved membrane stability in these plants.

Preconditioning of plants has also been shown to increase antioxidant levels in plants prior to cryopreservation (Baek & Skinner, 2003; Dai et al., 2009; Harding et al., 2009; Zhao & Blumwald, 1998). Baek and Skinner (2003) analysed the expression of antioxidant genes in wheat species after cold acclimation and found increased expression of antioxidant enzymes, such as SOD and catalase. Increased levels of antioxidants may allow plants to better tolerate oxidative stress. Lynch and Steponkus (1987) observed an increase in the di-unsaturated levels of PC and PE in winter rye seedlings. Sucrose pre-treatment of banana

meristems prior to cryopreservation increased survival after warming and was related in most cases to a decrease of the double bond index in phospholipids, free fatty acids, glycolipids and sphingolipids (Zhu et al., 2006).

## 5. Genetic and epigenetic stability

The aim of successful cryopreservation is to maintain genetically stable plant material. While cryopreservation is now recognised as the method of choice for the long term preservation of plant material, the usefulness of cryostorage only applies if it does not lead to genetic changes in the plant species of interest (Zarghami et al., 2008). It is thus recommended to avoid the use of tissue in a non-organised dedifferentiated state, such as callus, and to use organised tissue like shoot tips instead to reduce the likelihood of non-desirable genetic mutations (Benson et al., 1996; Harding, 2004) as well as due to their higher regrowth rates (Bunn et al., 2007). Cryopreservation can cause injury at cellular level, but it is not clear if this injury can change the genetic composition of plants. The genetic stability of cryopreserved plants has nonetheless been confirmed for most of the analysed samples at morphological, histological and molecular level (Harding, 2004). Where differences between control and cryopreserved genotypes were found, it was suggested that the genetic changes might not be associated with the cryopreservation process itself, but rather that they are caused by the overall tissue culture, cryoprotection and regeneration process (Harding, 2004).

Comparisons of morphological development and analyses of the characteristics of control and cryopreserved plants have shown no differences in many species, such as *Prunus*, sugarcane, onion, kiwi, *Eucalyptus*, coffee, *Dendrobium* and *Cosmos* (Harding, 2004), as well as in the hybrid aspen (*Populus tremula*), an economically important woody plant and widely used model forest plant (Jokipii et al., 2004). Alterations in phenotype related to flower colouring have been observed in *Chrysanthemum*, which might be related to the chimeric structure of the plant (Harding, 2004). Morphological and phenotypic studies in potato, where shoot tips were used for cryopreservation, showed stable genetic integrity (Kaczmarczyk et al., 2010). Biometric studies examining morphological characters, agronomic traits or vegetal development descriptors in *Dioscorea floribunda*, sugarcane and banana revealed no significant differences between cryopreserved-derived and control plants (Harding, 2004). No abnormalities in chromosome number or cell structure were observed in cryopreserved *Vanda pumila* (*Orchidaceae*), with the regrown shoot primordia being able to induce new meristematic tissues like those of the non-cryopreserved controls (Na & Kondo, 1996). Long term storage of cryopreserved plants, such as strawberry, pea, *Rubus* and potato, did not result in any overall changes in regeneration capability and phenotype when regenerated explants were compared at the time point of storage as well as 10, 12 and 28 years later (Castillo et al., 2010; Caswell & Kartha, 2009; Keller et al., 2006; Mix-Wagner et al., 2003).

Histological studies and cytological analysis using flow cytometry have confirmed the genetic stability of plant species such as pea, oil palm, silver birch, *Rubus*, *Solanum tuberosum* and rice (Harding, 2004). Biochemical analyses have compared products of gene expression such as the formation and concentration of secondary metabolites. Examples of compounds compared in cryopreserved and control plants have been diosgenin in *Dioscorea floribunda*, chlorophyll and pyrethrin in *Chrysanthemum*, hypericin production in *Hypericum perforatum*



L. (Skyba et al., 2010; Urbanova et al., 2006), betalain pigments in *Beta vulgaris* and nicotin alkaloids in *Nicotiana rustica*, which were all unchanged in cryopreserved plants and thus confirmed the integrity of metabolic functions after cryostorage (Harding, 2004). Similar stability was observed upon comparison of proteins and enzymes (Marin et al., 1993; Paulet et al., 1993; Wu et al., 2001).

A variety of different techniques and markers have been applied to compare genomic DNA patterns, such as restriction fragment length polymorphism (RFLP), randomly amplified polymorphic DNA (RAPDs) fragments, simple sequence repeat (SSR) analysis and amplified fragment length polymorphism (AFLP). Most studies have confirmed the presence of genetic stability (Castillo et al., 2010; Helliott et al., 2002) and where changes in the genome have been found, such as in sugarcane and potato with RFLP markers, the changes could not be related to the process of cryopreservation itself (Castillo et al., 2010; Harding, 2004).

In contrast to genetic variations manifested by DNA nucleotide sequence alterations, epigenetic changes do not change the original DNA sequence (Boyko & Kovalchuk, 2008) but can result in heritable changes of gene expression. Typical features of epigenetic characteristics are DNA methylation, histone modification and changes in chromatin structure (Boyko & Kovalchuk, 2008). Epigenetic gene regulatory mechanisms have a function in plant development and might be influenced or changed by environmental conditions and osmotic stress during tissue culture and cryopreservation. Some recent studies have analysed epigenetic characteristics like DNA methylation in tissue culture and cryopreserved plants. Modifications in DNA methylation have been found in almond (Channuntapipat et al., 2003), papaya (Kaity et al., 2008), chrysanthemum (Martín & González-Benito, 2006), *Ribes* (Johnston et al., 2009), strawberry (Hao et al., 2002a), citrus (Hao et al., 2002b) and potato (Kaczmarczyk et al., 2010). Changes in methylation might be caused by stressful *in vitro* conditions, osmotic dehydration and the application of cryoprotective agents (Harding, 2004).

## 6. Conclusion

Many plant species have been successfully cryopreserved through the development of various cryopreservation methods. As a standard protocol, vitrification and droplet vitrification are widely applied. Shoot tips are the preferred material for cryostorage as they contain the meristem and an organised structure, with direct shoot development avoiding unstructured phases, which could lead to mutations. Preconditioning of plants (cold acclimation or sugar preculture) can have positive effects on survival and regeneration after cryopreservation, which could be due to increased membrane stability. Cryopreserved plants have been found to be genetically stable in most cases, but epigenetic changes have been detected, although most of the molecular analyses have only compared fractions of the genome.

Success in cryopreservation cannot be guaranteed for all plants, as some species are recalcitrant to tissue culture or the cryopreservation process. Fundamental studies looking at membrane composition, membrane damage and repair are likely to help to elucidate why some species are cryosensitive and how cryopreservation protocols can be improved for those species.

## 7. Acknowledgment

The authors thank ALCOA of Australia Ltd and BHP Billiton Worsley Alumina Pty Ltd for their generous support. AK is supported through the Australian Research Council Linkage Project Grant LP0884027. BF is supported through an Australian Postgraduate Award and a Curtin Research Scholarship. Dr. Zak Hughes is gratefully acknowledged for producing Fig. 3.

## 8. References

- Anchordoguy, T.J., Rudolph, A.S., Carpenter, J.F. & Crowe, J.H. (1987). Modes of interaction of cryoprotectants with membrane phospholipids during freezing. *Cryobiology* 24:pp. 324-331.
- Arakawa, T., Carpenter, J.F., Kita, Y.A. & Crowe, J.H. (1990). The basis for toxicity of certain cryoprotectants - a hypothesis. *Cryobiology* 27:pp. 401-415.
- Baek, K-H. & Skinner, D.Z. (2003). Alteration of antioxidant enzyme gene expression during cold acclimation of near isogenic wheat lines. *Plant Science* 165:pp. 1221-1227.
- Benson, E.E. (1990). *Free Radical Damage in Stored Plant Germplasm*, International Board for Plant Genetic Resources, ISBN 92-9043-196-2, Rome, Italy.
- Benson, E.E. (2008). Cryopreservation of phytodiversity: A critical appraisal of theory & practice. *Critical Reviews in Plant Sciences* 27:pp. 141-219.
- Benson, E.E. & Bremner, D. (2004). Oxidative stress in the frozen plant: a free radical point of view. In: *Life in the Frozen State*, Fuller, B.J., Lane, N. & Benson, E.E. (Eds.), pp. 206-241, CRC Press, ISBN 0-415-24700-4, Boca Raton, Florida.
- Benson, E.E., Lynch, P.T. & Jones, J. (1992). The detection of lipid peroxidation products in cryoprotected and frozen rice cells: consequences for post-thaw survival. *Plant Science* 85:pp. 107-114.
- Benson, E.E., Lynch, P.T. & Jones, J. (1995). The use of the iron chelating agent desferrioxamine in rice cell cryopreservation: a novel approach for improving recovery. *Plant Science* 110:pp. 249-258.
- Benson, E.E., Reed, B.M., Brennan, R.M., Clacher, K.A. & Ross, D.A. (1996). Use of thermal analysis in the evaluation of cryopreservation protocols for *Ribes nigrum* L. germplasm. *CryoLetters*. 17:pp. 347-362.
- Benson, E.E. & Whithers, L.A. (1987). Gas-chromatographic analysis of volatile hydrocarbon production by cryopreserved plant-tissue cultures - a nondestructive method for assessing stability. *CryoLetters* 8:pp. 35-46.
- Boyko, A. & Kovalchuk, I. (2008). Epigenetic control of plant stress response. *Environmental and Molecular Mutagenesis* 49:pp. 61-72.
- Bunn, E., Turner, S., Panaia, M. & Dixon, K.W. (2007). The contribution of in vitro technology and cryogenic storage to conservation of indigenous plants, *Australian Journal of Botany* 55:pp. 345-355.
- Castillo, N.R.F., Bassil, N.V., Wada, S. & Reed, B.M. (2010). Genetic stability of cryopreserved shoot tips of *Rubus* germplasm. *In Vitro Cellular & Developmental Biology-Plant* 46:pp. 246-256.
- Caswell, K.L. & Kartha, K.K. (2009). Recovery of plants from pea and strawberry meristems cryopreserved for 28 years. *CryoLetters* 30:pp. 41-46.

- Channuntapipat, C., Sedgley, M. & Collins, G. (2003). Changes in methylation and structure of DNA from almond tissues during in vitro culture and cryopreservation. *J. Amer. Soc. Hort. Sci.* 128:pp. 890-897.
- Chen, X.-L., Li, J.-H., Xin, X., Zhang, Z.-E., Xin, P.-P. & Lu, X.-X. (2011). Cryopreservation of in vitro-grown apical meristems of *Lilium* by droplet-vitrification. *South African Journal of Botany* 77:pp. 397-403
- Crowe, J.H., Crowe, L.M., Carpenter, J.F., Rudolph, A.S., Wistrom, C.A., Spargo, B.J. & Anchordoguy, T.J. (1988). Interactions of sugars with membranes. *Biochimica et Biophysica Acta* 947:pp. 367-84.
- Dai, F., Huang, Y., Zhou, M. & Zhang G. (2009). The influence of cold acclimation on antioxidant enzymes and antioxidants in sensitive and tolerant barley cultivars. *Biologia Plantarum* 153:pp. 257-262.
- Day, J.G., Harding, K.C., Nadarajan, J. & Benson, E.E. (2008). Cryopreservation, conservation of bioresources at ultra low temperatures. In: *Molecular Biotechnology Handbook*. Walker J.M & Rapley R. (Eds.), pp. 917-947, Humana Press, ISBN 978-1-60327-374-9, Totowa, NJ.
- Day, J.G. & Stacey, G.N. (2007). *Cryopreservation and Freeze-Drying Protocols*. Humana Press Inc., ISBN 978-1-58829-377-0, Totowa, NJ.
- Decruse, S.W., Seeni, S. & Pushpangadan, P. (1999). Cryopreservation of alginate coated shoot tips of in vitro grown *Holostemma annulare* (Roxb.) K. Schum, an endangered medicinal plant: Influence of preculture and DMSO treatment on survival and regeneration. *CryoLetters* 20:pp. 243-250.
- Dowdle, J., Ishikawa, T., Gatzek, S., Rolinski, S. & Smirnoff, N. (2007). Two genes in *Arabidopsis thaliana* encoding GDP 1 galactose phosphorylase are required for ascorbate biosynthesis and seedling viability. *The Plant Journal* 52:pp. 673-689.
- Dowgert, M.F. & Steponkus, P.L. (1984). Behavior of the plasma membrane of isolated protoplasts during a freeze-thaw cycle. *Plant Physiol* 75:pp. 1139-1151.
- Emmelot, P. & Vanhoeven, R.P. (1975). Phospholipid unsaturation and plasma membrane organization. *Chemistry and Physics of Lipids* 14:pp. 236-246.
- Engelmann, F. (2004). Plant cryopreservation: Progress and prospects. *In Vitro Cellular & Developmental Biology-Plant* 40:pp. 427-433.
- Fabre, J. & Dereuddre, J. (1990). Encapsulation-dehydration: A new approach to cryopreservation of *Solanum* shoot-tips. *CryoLetters* 11:pp. 423-426.
- Fang, J.Y., Wetten, A. & Johnston, J. (2008). Headspace volatile markers for sensitivity of cocoa (*Theobroma cacao* L.) somatic embryos to cryopreservation. *Plant Cell Reports* 27: pp. 453-461.
- Fleck, R.A., Benson, E.E., Bremner, D.H. & Day, J.G. (2000). Studies of free radical-mediated cryoinjury in the unicellular green alga *Euglena gracilis* using a non-destructive hydroxyl radical assay: a novel approach for developing protistan cryopreservation strategies. *Free Radic Res* 32:pp. 157-70.
- Foubert, I., Dewettinck, K., Van de Walle, D., Dijkstra, A.J. & Quinn, P.J. (2007). Physical properties: structural and physical characteristics, In: *The Lipid Handbook with CD-ROM*, Gunstone, F.D., Harwood J.L. & Dijkstra A.J. (Eds.), pp. 471-534, CRC Press, Taylor & Francis Group, ISBN 0-8493-9688-3, LLC, Boca Raton, FL.

- Foyer, C.H. & Noctor, G. (2009). Redox regulation in photosynthetic organisms: signaling, acclimation, and practical implications. *Antioxidants & Redox Signaling* 11:pp. 861-905.
- Furt, F., Simon-Plas, F. & Sebastien, M. (2011). Lipids of the plant plasma membrane, In: *The Plant Plasma Membrane*. Murphy, A.S., Peer, W. & Schulz, B. (Eds.), pp. 3-30, Springer-Verlag, ISBN 978-3-642-13430-2, Berlin Heidelberg.
- Gamez-Pastrana, R., Martinez-Ocampo, Y., Beristain, C.I. & Gonzalez-Arnao, M.T. (2004). An improved cryopreservation protocol for pineapple apices using encapsulation-vitrification. *CryoLetters* 25:pp. 405-414.
- Gonzalez-Arnao, M.T., Panta, A., Roca, W.M., Escobar, R.H. & Engelmann, F. (2008). Development and large scale application of cryopreservation techniques for shoot and somatic embryo cultures of tropical crops. *Plant Cell Tissue and Organ Culture* 92:pp. 1-13.
- Gordon-Kamm, W.J. & Steponkus, P.L. (1984). Lamellar-to-hexagonal II phase transitions in the plasma membrane of isolated protoplasts after freeze-induced dehydration. *Proc Natl Acad Sci USA* 81:pp. 6373-6377.
- Grunwald, C. (1975). Plant sterols. *Annual Review of Plant Physiology and Plant Molecular Biology* 26:pp. 209-236.
- Grunwald, C. & Saunders, P.F. (1978). Function of sterols [and discussion]. *Philosophical Transactions of the Royal Society of London B Biological Sciences* 284:pp. 541-558.
- Gupta, S. & Reed, B.M. (2006). Cryopreservation of shoot tips of blackberry and raspberry by encapsulation-dehydration and vitrification. *CryoLetters* 27:pp. 29-42.
- Guy, C.L., Niemi, K.J. & Brambl, R. (1985). Altered gene expression during cold acclimation of spinach. *Proc Natl Acad Sci USA* 82: pp. 3673-3677.
- Halliwell, B. & Gutteridge, J.M.C. (2007). *Free Radicals in Biology and Medicine* (Fourth edition), Oxford University Press Inc., ISBN 978-0-19-856868-1, Oxford.
- Halmagyi, A., Fischer-Klüver, G., Mix-Wagner, G. & Schumacher, H.M. (2004). Cryopreservation of *Chrysanthemum morifolium* (*Dendranthema grandiflora* Ramat.) using different approaches. *Plant Cell Rep* 22:pp. 371-375.
- Hamilton, K.N., Turner, S.R. & Ashmore, S.E. (2009). Cryopreservation, In: *Plant Germplasm Conservation in Australia: Strategies and Guidelines for Developing, Managing and Utilising Ex Situ Collections*, Offord, C.A & Meagher, P.F. (Eds.), pp. 129-128, Australian Network for Plant Conservation Inc., ISBN 978-0-9752191-1-9, Canberra.
- Hao, Y.J., You, C.X. & Deng, X.X. (2002a). Analysis of ploidy and the patterns of amplified fragment length polymorphism and methylation sensitive amplified polymorphism in strawberry plants recovered from cryopreservation. *CryoLetters* 23:pp. 37-46.
- Hao, Y.J., You, C.X. & Deng, X.X. (2002b). Effects of cryopreservation on developmental competency, cytological and molecular stability of citrus callus. *CryoLetters* 23:pp. 27-35.
- Harding, K. (2004). Genetic integrity of cryopreserved plant cells: a review. *CryoLetters* 25:pp. 3-22.
- Harding, K.N., Johnston, J.W. & Benson, E.E. (2009). Exploring the physiological basis of cryopreservation success and failure in clonally propagated in vitro crop plant germplasm. *Agricultural and Food Science* 18:pp. 103-116.

- Hartmann, M.A. (1998). Plant sterols and the membrane environment. *Trends in Plant Science* 3:pp. 170-175.
- Helliot, B., Madur, D., Dirlewanger, E. & De Boucaud, M.T. (2002). Evaluation of genetic stability in cryopreserved *Prunus*. *In Vitro Cellular & Developmental Biology-Plant* 38:pp. 493-500.
- Hipkiss, A.R., Preston, J.E., Himsworth, D., Worthington, V.C. & Abbot, N.J. (1997). Protective effects of carnosine against malondialdehyde-induced toxicity towards cultured rat brain endothelial cells. *Neuroscience Letters* 238:pp. 135-138.
- Hirai, D. & Sakai, A. (1999). Cryopreservation of in vitro-grown meristems of potato (*Solanum tuberosum* L.) by encapsulation-vitrification. *Potato Research* 42:pp. 153-160.
- Hirai, D., Shirai, K., Shirai, S. & Sakai, A. (1998). Cryopreservation of in vitro grown meristems of strawberry (*Fragaria x ananassa* Duch.) by encapsulation-vitrification. *Euphytica* 101:pp. 109-115.
- Hodzic, A., Rappolt, M., Amenitsch, H., Laggner, P. & Pabst, G. (2008). Differential modulation of membrane structure and fluctuations by plant sterols and cholesterol. *Biophysical Journal* 94:pp. 3935-3944.
- Johnston, J.W., Benson, E.E. & Harding, K. (2009). Cryopreservation induces temporal DNA methylation epigenetic changes and differential transcriptional activity in *Ribes* germplasm. *Plant Physiology and Biochemistry* 47:pp. 123-131.
- Jokipii, S., Rynänen, L., Kallio, P.T., Aronen, T. & Häggmana, H. (2004). A cryopreservation method maintaining the genetic fidelity of a model forest tree, *Plant Science*. 166:pp. 799-806.
- Kaczmarczyk, A., Houben, A., Keller, E.R.J. & Mette, M.F. (2010). Influence of cryopreservation on the cytosine methylation state of potato genomic DNA. *CryoLetters* 31:pp. 380-391.
- Kaczmarczyk, A., Rokka, V.-M. & Keller, E.R.J. (2011a). Potato shoot tip cryopreservation, a review. *Potato Research* 54:pp. 45-79.
- Kaczmarczyk, A., Turner, S.R., Bunn, E., Mancera, R.L. & Dixon, K.W. (2011b). Cryopreservation of threatened native Australian species - what have we learned and where to from here? *In Vitro Cellular & Developmental Biology-Plant* 47:pp. 17-25.
- Kaity, A., Ashmore, S.E., Drew, R.A. & Dulloo, M.E. (2008). Assessment of genetic and epigenetic changes following cryopreservation in papaya. *Plant Cell Reports* 27:pp. 1529-1539.
- Keller, E.R.J., Senula, A., Leunufna, S. & Grube, M. (2006). Slow growth storage and cryopreservation - tools to facilitate germplasm maintenance of vegetatively propagated crops in living plant collections. *International Journal of Refrigeration-Revue Internationale Du Froid* 29:pp. 411-417.
- Kent, B., Garvey, C.J., Lenne, T., Porcar, L., Garamus, V.M. & Bryant, G. (2010). Measurement of glucose exclusion from the fully hydrated DOPE inverse hexagonal phase. *Soft Matter* 6:pp. 1197-1202.
- Kim, H.H., Lee, Y.G., Shin, D.J., Ko, H.C., Gwag, J.G., Cho, E.G. & Engelmann, F. (2009). Development of alternative plant vitrification solutions in droplet-vitrification procedures. *CryoLetters* 30:pp. 320-34.
- Kranner, I., Birtic, S., Anderson, K.M. & Pritchard, H.W. (2006). Glutathione half-cell reduction potential: A universal stress marker and modulator of programmed cell death? *Free Radical Biology and Medicine* 40:pp. 2155-2165.

- Kreck, C.A., Mandumpal, J.B. & Mancera, R.L. (2011). Prediction of the glass transition in aqueous solutions of simple amides by molecular dynamics simulations. *Chemical Physics Letters* 501:pp. 273-277.
- Lenne, T., Bryant, G., Garvey, C.J., Kelderling, U. & Koster, K.L. (2006). Location of sugars in multilamellar membranes at low hydration. *Physica B-Condensed Matter* 385-86:pp. 862-864.
- Lenne, T., Bryant, G., Holcomb, R. & Koster, K.L. (2007). How much solute is needed to inhibit the fluid to gel membrane phase transition at low hydration? *Biochimica et Biophysica Acta-Biomembranes* 1768:pp. 1019-1022.
- Lenne, T., Garvey, C.J., Koster, K.L. & Bryant, G. (2009). Effects of sugars on lipid bilayers during dehydration - SAXS/WAXS measurements and quantitative model. *Journal of Physical Chemistry B*, 113:pp. 2486-2491.
- Leunufna, S. & Keller, E.R.J. (2005). Cryopreservation of yams using vitrification modified by including droplet method: effects of cold acclimation and sucrose. *CryoLetters* 26:pp. 93-102.
- Lynch, D.V. & Steponkus, P.L. (1987). Plasma membrane lipid alterations associated with cold acclimation of winter rye seedlings (*Secale cereale* L. cv Puma). *Plant Physiol* 83:pp. 761-767.
- Lynch, P.T., Siddika, A., Johnston, J.W., Trigwell, S.M., Mehra, A., Benelli, C., Lambardi, M. & Benson, E.E. (2011). Effects of osmotic pretreatments on oxidative stress, antioxidant profiles and cryopreservation of olive somatic embryos. *Plant Science* 181:pp. 47-56.
- Mallon, R., Bunn, E., Turner, S.R. & Gonzalez, M.L. (2008). Cryopreservation of *Centaurea ulreia* (Compositae) a critically endangered species from Galica (Spain). *CryoLetters* 29:pp. 363-370.
- Mandal, B.B. & Dixit-Sharma, S. (2007). Cryopreservation of in vitro shoot tips of *Dioscorea deltoidea* Wall., an endangered medicinal plant: effect of cryogenic procedure and storage duration. *CryoLetters* 28:pp. 461-470.
- Mandumpal, J.B., Kreck, C.A. & Mancera, R.L. (2011). A molecular mechanism of solvent cryoprotection in aqueous DMSO solutions. *Physical Chemistry Chemical Physics* 13:pp. 3839-3842.
- Marin, M.L., Gogorcena, Y., Ortiz, J. & Duranvila, N. (1993). Recovery of whole plants of sweet orange from somatic embryos subjected to freezing-thawing treatments. *Plant Cell Tissue and Organ Culture* 34:pp. 27-33.
- Marnett, L.J. (1999). Chemistry and biology of DNA damage by malondialdehyde. *IARC scientific publications* 150:pp. 1-17.
- Marsan, M.P., Bellet-Amalric, E., Muller, I., Zaccari, G. & Milon, A. (1998). Plant sterols: a neutron diffraction study of sitosterol and stigmaterol in soybean phosphatidylcholine membranes. *Biophysical Chemistry* 75:pp. 45-55.
- Martin, M.C. & González-Benito, M. E. (2006) Sequence comparison in somaclonal variant of cryopreserved *Dendranthema grandiflora* shoot apices. *Cryobiology* 53:pp. 424.
- Meryman, H.T. (1974). Freezing injury and its prevention in living cells *Annual Review of Biophysics and Bioengineering* 3:pp. 341-363.
- Mix-Wagner, G., Schumacher, H.M. & Cross, R.J. (2003). Recovery of potato apices after several years of storage in liquid nitrogen. *CryoLetters* 24:pp. 33-41.

- Møller, I.M., Jensen, P.E. & Hansson, A. (2007). Oxidative modifications to cellular components in plants. *Annu. Rev. Plant Biol.* 58:pp. 459-481.
- Mycock, D.J., Wesley-Smith, J. & Berjak, P. (1995). Cryopreservation of somatic embryos of four species with and without cryoprotectant pre-treatment. *Annals of Botany* 75: pp. 331-336.
- Na, H.-Y. & Kondo, K. (1996). Cryopreservation of tissue-cultured shoot primordia from shoot apices of cultured protocorms in *Vanda pumila* following ABA preculture and desiccation. *Plant Science* 118:pp. 195-201.
- Nes, W.R. (1974). Role of sterols in membranes. *Lipids* 9:pp. 596-612.
- Nishizawa, S., Sakai, A., Amano, Y. & Matsuzawa, T. (1993). Cryopreservation of *Asparagus officinalis* L. embryogenic suspension cells and subsequent plant regeneration by vitrification. *Plant Science* 91:pp. 67-73.
- Obert, B., Benson, E.E., Millam, S., Pretová, A. & Bremner, D.H. (2005). Moderation of morphogenetic and oxidative stress responses in flax in vitro cultures by hydroxynonenal and desferrioxamine. *Journal of Plant Physiology* 162:pp. 537-547.
- Packer, J.E., Slater, T. & Willson, R. (1979). Direct observation of a free radical interaction between vitamin E and vitamin C. *Nature* 278:pp. 737-738.
- Panis, B., Strosse, H., Van den Hende, S. & Swennen, R. (2002). Sucrose preculture to simplify cryopreservation of banana meristem cultures. *CryoLetters* 23:pp. 375-384.
- Panis, B. & Lambardi, M. (2005). Status of cryopreservation technologies in plants (crops and forest trees). Proceedings of the International Workshop on 'The Role of Biotechnology', pp. 43-54, Villa Gualino, Turin, Italy, 5.-7. March 2005.
- Panis, B., Piette, B. & Swennen, R. (2005). Droplet vitrification of apical meristems: a cryopreservation protocol applicable to all Musaceae. *Plant Science* 168:pp. 45-55.
- Partelli, F.L., Vieira, H.D., Pais, I.P., Quartin, V.L., Campos, P.S., Fortunato, A., Eichler, P., Viana, A.P., Ribeiro, A. & Ramalho, J.C. (2009). Chloroplast membrane lipids from *Coffea* sp. under low positive temperatures. Proceedings of 22nd International Conference on Coffee Science, pp. 891-898, ASIC 2008, ISBN 2900212219, Campinas, SP, Brazil, September, 2008.
- Paulet, F., Engelmann, F. & Glaszmann, J.C. (1993). Cryopreservation of apices of in vitro plantlets of sugarcane (*Saccharum* sp hybrids) using encapsulation dehydration. *Plant Cell Reports* 12:pp. 525-529.
- Paunescu, A. (2009). Biotechnology for endangered plant conservation: a critical overview *Romanian Biotechnological Letters* 14:pp. 4095-4103.
- Reed, B.M. (2008). *Plant Cryopreservation: A Practical Guide*, Springer, ISBN 978-0-387-72275-7, New York.
- Reinhou, P.J., Verstege, I., Kars, I., van Iren, F. & Kijne, J.W. (2000). Physiological and molecular changes in tobacco suspension cells during development of tolerance to cryopreservation by vitrification, In: *Cryopreservation of Tropical Plant Germplasm. Current Research Progress and Application*, Engelmann, F. & Takagi, H. (Eds.), pp. 57-66, International Plant Genetic Resources Institute, ISBN 92-9043-428-7, Rome.
- Roach, T., Ivanova, M., Beckett, R.P., Minibayeva, F.V., Green, I., Pritchard, H.W. & Kranner, I. (2008). An oxidative burst of superoxide in embryonic axes of recalcitrant sweet chestnut seeds as induced by excision and desiccation. *Physiologia Plantarum* 133:pp. 131-139.

- Sakai, A. (1965). Survival of plant tissue at super-low temperatures III. Relation between effective prefreezing temperatures and the degree of frost hardiness. *Plant Physiol.* 40:pp. 882-887.
- Sakai, A. & Engelmann, F. (2007). Vitrification, encapsulation-vitrification and droplet-vitrification: a review. *CryoLetters* 28:pp. 151-172.
- Sakai, A., Hirai, D. & Niino, T. (2008). Development of PVS-based vitrification and encapsulation-vitrification protocols, In: *Plant Cryopreservation: A Practical Guide*, Reed, B. (Ed.), pp. 33-57, Springer, ISBN 978-0-378-72275-7, New York.
- Sakai, A., Kobayashi, S. & Oiyama, I. (1990). Cryopreservation of nucellar cells of navel orange (*Citrus sinensis* Osb. var. *brasiliensis* Tanaka) by vitrification. *Plant Cell Reports* 9:pp. 30-33.
- Scottex, C., Chevreau, E., Godard, N., Arnaud, Y., Duron, M. & Dereuddre, J. (1992). Cryopreservation of cold acclimated shoot tips of pear in vitro cultures after encapsulation-dehydration. *Cryobiology* 29:pp. 691-700.
- Sen-Rong, H. & Ming-Hua, Y. (2009). High-efficiency vitrification protocols for cryopreservation of in vitro grown shoot tips of rare and endangered plant *Emmenopterys henryi* Oliv. *Plant Cell Tissue and Organ Culture* 99:pp. 217-226.
- Senula, A., Keller, E.R.J., Sanduijav, T. & Yohannes, T. (2007). Cryopreservation of cold-acclimated mint (*Mentha* spp.) shoot tips using a simple vitrification protocol. *CryoLetters* 28:pp. 1-12.
- Skyba, M., Urbanova, M., Kapchina-Toteva, V., Kosuth, J., Harding, K. & Cellarova, E. (2010). Physiological, biochemical and molecular characteristics of cryopreserved *Hypericum perforatum* L. shoot tips. *CryoLetters* 31:pp. 249-260.
- Steponkus, P.L. (1984). Role of the plasma membrane in freezing injury and cold acclimation. *Annual Review of Plant Physiology* 35:pp. 543-584.
- Streb, P., Shang, W., Feierabend, J. & Bligny, R. (1998). Divergent strategies of photoprotection in high-mountain plants. *Planta* 207:pp. 313-324.
- Takagi, H., Thinh, N.T., Islam, O.M., Senboku, T. & Sakai, A. (1997). Cryopreservation of in vitro-grown shoot tips of taro (*Colocasia esculenta* (L.) Schott) by vitrification 1. Investigation of basic conditions of the vitrification procedure. *Plant Cell Reports* 16:pp. 594-599.
- Tanaka, D., Niino, T., Isuzugawa, K., Hikage, T. & Uemura, M. (2004). Cryopreservation of shoot apices of in-vitro grown gentian plants: Comparison of vitrification and encapsulation-vitrification protocols. *CryoLetters* 25:pp. 167-176.
- Thomashow, M.F. (1999). Plant cold acclimation: Freezing tolerance genes and regulatory mechanisms. *Annual Review of Plant Physiology and Plant Molecular Biology* 50:pp. 571-599.
- Touchell, D.H., Dixon, K.W. & Tan, B. (1992). Cryopreservation of shoot-tips of *Grevillea scapigera* (Proteaceae) - a rare and endangered plant from Western-Australia. *Australian Journal of Botany* 40:pp. 305-310.
- Touchell, D.H., Turner, S.R., Bunn, E. & Dixon, K.W. 2002. Cryostorage of somatic tissues of endangered Australian species, In: *Cryopreservation of Plant Germplasm*. Towill, L.E. & Bajaj, Y.P.S. (Eds.), pp. 357-372, Springer Verlag, ISBN 7055-8630, Berlin Heidelberg, Germany.



- Turner, S. 2001. *Cryopreservation of somatic germplasm of selected Australian monocotyledonous taxa (Haemodoraceae)*, PhD Thesis, Curtin University of Technology, Perth, Western Australia.
- Turner, S., Senaratna, T., Touchell, D., Bunn, E., Dixon, K. & Tan, B. (2001). Stereochemical arrangement of hydroxyl groups in sugar and polyalcohol molecules as an important factor in effective cryopreservation. *Plant Science* 160:pp. 489-497.
- Uchendu, E.E., Leonard, S.W., Traber, M.G. & Reed, B.M. (2010). Vitamins C and E improve regrowth and reduce lipid peroxidation of blackberry shoot tips following cryopreservation. *Plant Cell Reports* 29:pp. 25-35.
- Uemura, M. & Steponkus, P.L. (1994). A contrast of the plasma membrane lipid composition of oat and rye leaves in relation to freezing tolerance. *Plant Physiology* 104:pp. 479-496.
- Uemura, M., Joseph, R.A. & Steponkus, P.L. (1995). Cold-acclimation of *Arabidopsis thaliana* - effect on plasma membrane lipid composition and freeze-induced lesions. *Plant Physiology* 109:pp. 15-30.
- Urbanova, M., Kosuth, J. & Cellarova, E. (2006). Genetic and biochemical analysis of *Hypericum perforatum* L. plants regenerated after cryopreservation. *Plant Cell Reports* 25:pp. 140-147.
- van Meer, G., Voelker, D.R. & Feigenson, G.W. (2008). Membrane lipids: where they are and how they behave. *Nature Reviews Molecular Cell Biology* 9:pp. 112-124.
- Vidal, N., Sanchez, C., Jorquera, L., Ballester, A. & Vieitez, A.M. (2005). Cryopreservation of chestnut by vitrification of in vitro-grown shoot tips. *In Vitro Cellular & Developmental Biology-Plant* 41:pp. 63-68.
- Volk, G.M. & Walters, C. (2006). Plant vitrification solution 2 lowers water content and alters freezing behavior in shoot tips during cryoprotection. *Cryobiology* 52:pp. 48-61.
- Wang, Z.C. & Deng, X.X. (2004). Cryopreservation of shoot-tips of citrus using vitrification: effect of reduced form of glutathione. *CryoLetters* 25:pp. 43-50.
- Wise, R.R. (1995). Chilling-enhanced photooxidation: the production, action and study of reactive oxygen species produced during chilling in the light. *Photosynthesis Research* 45:pp. 79-97.
- Wise, R.R. & Naylor, A.W. (1987). Chilling-enhanced photooxidation: evidence for the role of singlet oxygen and superoxide in the breakdown of pigments and endogenous antioxidants. *Plant Physiology* 83:pp. 278.
- Wolfe, J. & Bryant, G. (1999). Freezing, drying, and/or vitrification of membrane-solute-water systems. *Cryobiology* 39:pp. 103-129.
- Wu, Y.J., Zhao, Y.H., Engelmann, R. & Zhou, M.D. (2001). Cryopreservation of kiwi shoot tips. *CryoLetters* 22:pp. 277-284.
- Yoon, J.-W., Kim, H.-H., Ko, H.-C., Hwang, H.-S., Hong, E.-S., Cho, E.-G. & Engelmann, F. (2006). Cryopreservation of cultivated and wild potato varieties by droplet vitrification: effect of subculture of mother-plants and of preculture of shoot tips. *CryoLetters* 27:pp. 211-222.
- Young, I. & McEneny, J. (2001). Lipoprotein oxidation and atherosclerosis. *Biochemical Society Transactions* 29:pp. 358-362.
- Zarghami, R., Pirseyedi, S.M., Hasrak, Sh. & Pakdaman, B.S. (2008). Evaluation of genetic stability in cryopreserved *Solanum tuberosum*. *African Journal of Biotechnology* 7:pp. 2798-2802.

- Zhao, S. & Blumwald, E. (1998). Changes in oxidation reduction state and antioxidant enzymes in the roots of jack pine seedlings during cold acclimation. *Physiologia Plantarum* 104: pp.134-142.
- Zhu, G.Y., Geuns, J.M.C., Dussert, S., Swennen, R. & Panis, B. (2006). Change in sugar, sterol and fatty acid composition in banana meristems caused by sucrose-induced acclimation and its effects on cryopreservation. *Physiologia Plantarum* 128:pp. 80-94.

# Cryopreservation of Plant Genetic Resources

Daisuke Kami

*National Agricultural Research Center for Hokkaido Region  
Japan*

## 1. Introduction

The plant genetic resources is preserved by pollen, seed, branch, bulb, or tissue culture at the gene bank. Since these need to be updated periodically (several months ~ several years), I point out the problems involving the great labor and space spent for the maintenance of plant genetic resources.

Cryopreservation is a storage method of plant genetic resources at ultra-low temperature, for example, that of liquid nitrogen (LN; -196 °C). It is a preservation method that enables plant genetic resources to be conserved safely, and cost-effectively.

For successful cryopreservation, it is essential to avoid intracellular freezing and induce the vitrification state of plant cells during cooling in LN. In addition, the cryopreservation method should be a simple protocol for everyone to use easily. Since the 1970's, cryopreservation techniques have been researched using different plant organs, tissues and cells. As a result, different cryopreservation procedures have been developed (for example, slow-prefreezing method, vitrification method, dehydration method). With the development of these cryopreservation methods, tissues of tropical plants, which have been conventionally thought to be not cryopreserved, also were successfully preserved in LN (Bajaj, 1995; Towill & Bajaj, 2002). In this Chapter, I describe different types of cryopreservation methods.

In addition, I often ask my colleagues why cryopreservation of plant tissue did not succeed irrespective of the method. As the cause, it is possible that there is a problem in the character of plant species (stress resistance and polyphenol production), or the ways used in the cryopreservation technique. Then, I also would like to present some knowledge about some improvements for making cryopreservation of plant genetic resources more successful in this chapter.

## 2. Methods of cryopreservation of plant genetic resources

In the section (2.1), I would like to introduce cryopreservation methods of plant genetic resources that have been developed. In the section (2.2), I would like to describe the approach when cryopreserving plant samples from the past literatures or my own experience in order to enhance the regrowth percentage after cryopreservation,

## 2.1 Cryopreservation method of plant genetic resources

In this section, I introduce cryopreservation procedures by using figures.

### 2.1.1 Slow programmed freezing (also known as “prefreezing”)

Slow programmed freezing was a major cryopreservation method for plant genetic resources until the 1980's. The procedure in this method is shown in Fig. 1.

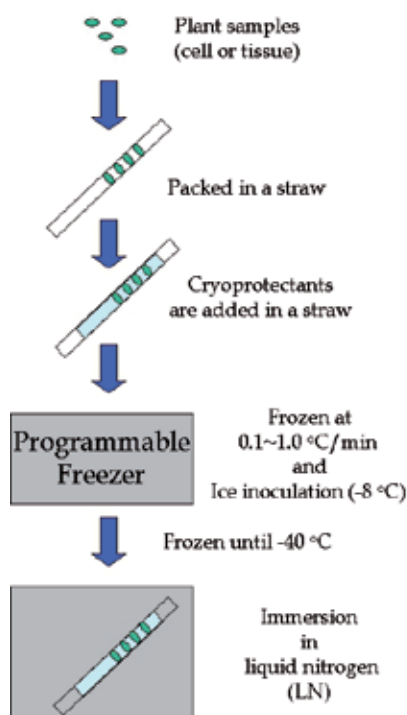

Fig. 1. The protocol of slow programmed freezing (from Kumu et al., 1983).

Plant genetic resources (cells and tissues) were packed in cryotube or straw, and cryoprotectants were added. In this method, dimethyl sulfoxide (DMSO), ethylene glycol (EG) and glucose were utilized as cryoprotectants. In many cases, these were used independently, but Finkle & Ulrich (1979) reported that the regrowth percentage of germplasm after cryopreservation was higher when mixing cryoprotectants in sugar cane cells. Packed specimens were gradually cooled from -20 °C to -100 °C using a programmable freezer or ethanol baths. Processing which freezes cryoprotectant in a tube artificially is performed near -7~-8 °C in the middle of the freezing. In this treatment, ice is made to form out of a cell under gradual cooling. Intracellular moisture penetrates a plasma membrane, and arrives at the surface of the ice besides a cell, and freezes. This is called 'extracellular freezing'. Intracellular moisture is removed and a cytoplasm is contracted by 'extracellular freezing'. Kindly refer to the book of Kartha (1985) to understand the principle of this phenomenon. After making specimens freeze to a predetermined freezing-temperature, they are immersed in LN. The freezing-temperature is arranged by -40 °C in many species. Cryopreserved tubes are warmed using hot water (40 °C) for 1~2 min, and cryoprotectants

are removed from a tube. After rewarming, samples are moved from the cryotube, and recultured. The cooling rate in this method is important. It differs from 0.5 °C/min to 50 °C/min with plant species and the size of the plant germplasm. However, in the case of the freezing speed of 2 °C/min or more, the regrowth after preservation tends to fall (Sugawara & Sakai, 1974; Uemura & Sakai, 1980). The disadvantage of this method is that there are many species for which the prefreezing method is not utilized at all. In addition, there are plant tissues which freeze to death partially, and cases in which the decrease in subsequent viability induced also exists (Grout & Henshaw, 1980; Haskins & Kartha, 1980).

### 2.1.2 Slow unprogrammed freezing (also known as “simple freezing”)

This cryopreservation method was reported using samples of several species in the early 1990's. The advantage of this method is that researchers can cryopreserve without a special programmable freezer, compared with slow programmed freezing.

The slow unprogrammed freezing is shown in Fig. 2. Plant tissues are added to the tube containing cryoprotectants. Tubes are treated for about 10 min at room temperature (25 °C), and are kept at -30 °C for 30~120 min. They are then immersed in LN thereafter. Cryopreserved tubes are warmed using hot water (40 °C) for 1~2 min, and cryoprotectants are removed from a tube. After rewarming, samples are moved from the cryotube, and recultured. In this cryopreservation method, mixtures of glycerol and sucrose or DMSO and sorbitol are used as cryoprotectants (Sakai et al., 1991; Niino et al., 1992; Maruyama et al., 2000). In this cryopreservation method, although ‘naked’ samples are used, Kobayashi et al. (2005) utilized cells encapsulated with alginate beads in the suspension cells of tobacco.

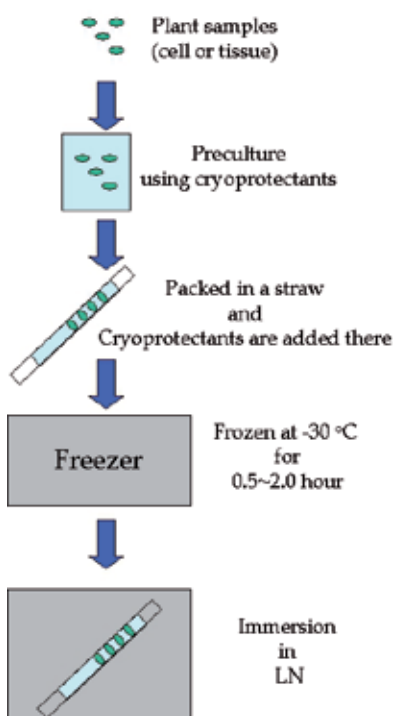

Fig. 2. The protocol of slow unprogrammed freezing (from Sakai et al., 1991).

### 2.1.3 Vitrification

The vitrification method has been the major cryopreservation method since Uragami et al. (1989) developed it using asparagus culture cells. This cryopreservation method is shown in Fig. 3. Plant tissues are added to the tube containing the loading solution (LS) for the osmoprotection. Beads in tubes are osmoprotected for about 30 min at room temperature (about 25 °C). LS is the liquid culture medium in which sucrose (0.4 mol/L) and the glycerol (2.0 mol/L) were contained. After loading, LS is removed from a tube, and new vitrification solution is added for the dehydration of plant tissues.

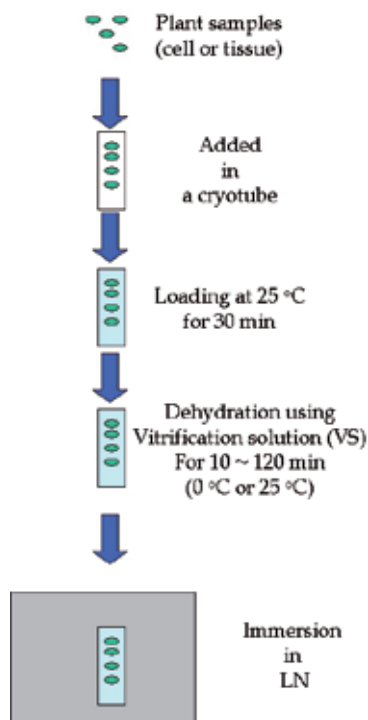

Fig. 3. The protocol of vitrification method (from Sakai et al., 1990).

Many cryoprotectants are dissolved in the vitrification solution, and the optimal dehydration time using the solution changes greatly with treatment temperature.

In many cases, the dehydration using the vitrification solution is performed at 0 °C by the reason of the toxicity to plant cells. Plant Vitrification Solution 2 (PVS2; Sakai et al., 1990) is utilized most as the vitrification solution. Besides PVS2, there are many vitrification solutions. Please refer to Table 1 for the composition. They are immersed in LN after that. Cryopreserved tubes are warmed using hot water (40 °C) for 1~2 min, and the vitrification solution is removed from a tube. After the removal of vitrification solution, unloading solution (the liquid medium supplemented with 1.2 mol/L sucrose) is added to a tube, and cryoprotectants are removed from plant tissues for 30 min at 25 °C. In many cases, the above-mentioned liquid mediums (LS, PVS and unloading solution) were adjusted by pH

5.7~5.8, but without plant growth regulators. After unloading, samples are removed from the cryotube, and recultured.

Component (g/L)	PVS1	PVS2	PVS3
Glycerol	220.0	300.0	500.0
Ethylene Glycol	150.0	150.0	
Propylene Glycol	150.0		
Dimethyl Sulfoxide (DMSO)	70.0	150.0	
Sucrose		136.9	500.0
Sorbitol	91.1		

Table 1. Components of major plant vitrification solutions. Components of three plant vitrification solutions are referred from previous reports (Uragami et al., 1989; Sakai et al., 1990; Nishizawa et al., 1993).

#### 2.1.4 Encapsulation-vitrification

The encapsulation-vitrification method was reported first by Matsumoto et al. (1995) using shoot apices of *Wasabia japonica*, and then spread all over the world. The advantage of this method is that regrowth of plant germplasm after cryopreservation is markedly increased by encapsulating plant samples with alginate beads. The encapsulation of plant germplasms makes for less damage to samples during vitrification procedures (loading treatment and dehydration treatment). On the other hand, due to encapsulation-dehydration, treatment time becomes long compared with that of vitrification and the cryopreservation operation becomes complicated (for example, encapsulation).

The procedure for encapsulation-vitrification is shown in Fig. 4. Plant tissues are immersed in the calcium-free liquid medium supplemented with 0.4 mol/L sucrose, 30.0 g/L sodium alginate and glycerol (1.0~2.0 mol/L). The mixture (including a plant cell or tissue) was added drop by drop to the liquid medium containing 0.1 mol/L calcium chloride, forming beads about 5 mm in diameter. The above-mentioned liquid mediums (30.0 g/L sodium alginate and 0.1 mol/L calcium chloride) were adjusted by pH 5.7, but without plant growth regulators. Encapsulated specimens are added to the culture bottle containing LS for osmoprotection. Beads in the bottles are osmoprotected for 16 hours at room temperature (25 °C). LS is the liquid culture medium in which sucrose (0.75~0.8 mol/L) and the glycerol (2.0 mol/L) were contained. After loading, LS is removed from a bottle, and PVS is added newly for the dehydration of plant tissues. The same as with vitrification, the dehydration using PVS is performed at 0 °C in light of the toxicity to plant cells.

After dehydration of PVS, encapsulated samples are moved to a cryotube containing fresh PVS, and immersed in LN. Cryopreserved tubes are warmed using hot water (40 °C) for 1~2 min, and the vitrification solution is removed from the tube. After removal of the solution, unloading solution (supplemented with 1.2 mol/L sucrose; pH 5.7) is added to a tube, and cryoprotectants are removed from plant tissues for 30 min at 25 °C. After unloading, samples are moved from the cryotube, and recultured.

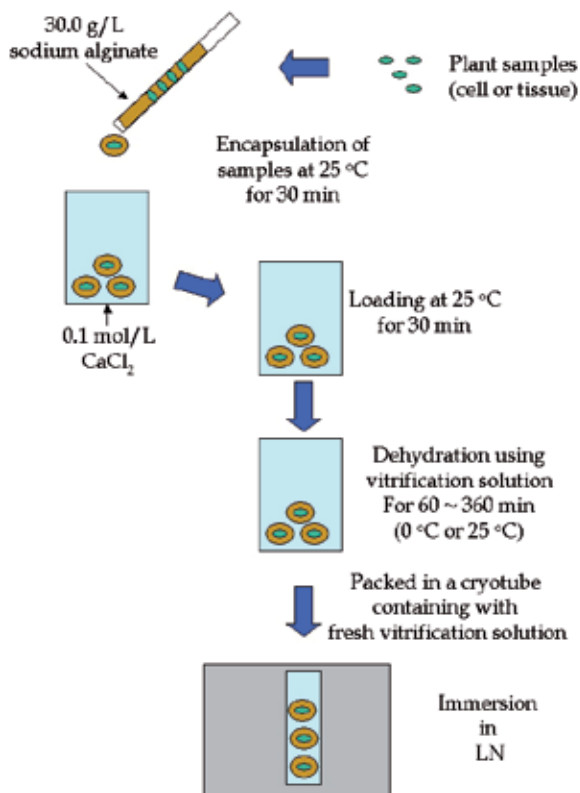

Fig. 4. The protocol of encapsulation-vitrification method (from Matsumoto et al., 1995)

### 2.1.5 Simplified encapsulation-vitrification

The simplified encapsulation-vitrification method was first reported by Hirai & Sakai (2002) using shoot apices of sweet potato. The operating procedure in this method is the same as encapsulation-vitrification (see Fig. 4), however, the composition of LS differs. LS of simplified encapsulation-vitrification includes high-concentration glycerol (2.0 mol/L) and sucrose (1.6 mol/L), and the viscosity of LS is high. Although this method succeeded with sweet potato, there are some plant species which cannot be cryopreserved using high concentration glycerol (Hirai & Sakai, 1999).

### 2.1.6 Droplet method

The droplet method was first reported by Schäfer-Menuhr et al. (1994, 1997) using potato apices. The operating procedure is the same for vitrification. However, the LS immersion protocol differs compared with that in the vitrification method. This cryopreservation method is shown in Fig. 5. After treatments by LS and PVS, plant samples are put on aluminum foil which is sterilized and cut small. One drop of PVS is dripped onto plant samples, and the whole aluminum foil is immersed in LN. The aluminum foil after cryopreservation is taken out from LN, and one drop of unloading solution supplemented with 1.0 mol/L sucrose is dripped onto to freezing samples. After rewarming, samples are



moved from the cryotube, and recultured. In the droplet method, in order to make a plant sample cool quickly, Wesley-Smith et al. (2001) used not liquid nitrogen but a slush nitrogen (-210 °C) and an isopentane (-160 °C). In addition, the droplet method can reportedly obtain a high regrowth percentage after cryopreservation in tropical plants difficult to cryopreserve (Pennycooke & Towill, 2000, 2001; Leunufna & Keller, 2003; Panis et al., 2005).

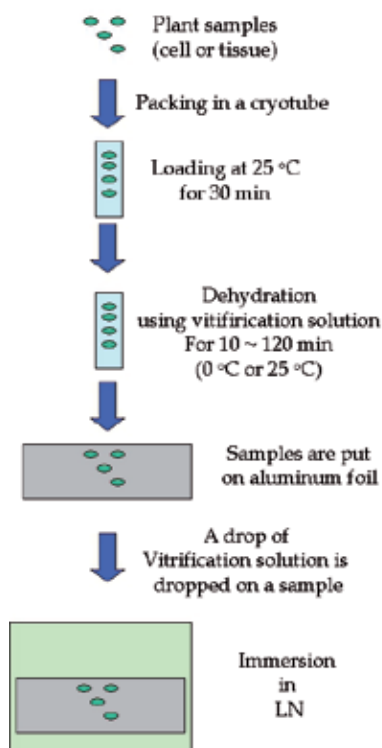

Fig. 5. The protocol of Droplet method (from Schäfer-menuhr et al., 1997).

### 2.1.7 Dehydration

Dehydration was first reported by Uragami et al. (1990) using asparagus lateral buds. A dry technique is superior to vitrification in that it does not need to produce PVS. Therefore, there is no influence of medical toxicity at low cost. Problems of dehydration include ready influence of humidity on drying by air flow and dried samples are easily crushed with tweezers.

The cryopreservation procedure is shown in Fig. 6. Plant tissues are put on the filter paper or nylon mesh sterilized and cut small. Samples are dehydrated by silica gel (Uragami et al., 1990) or air flow (Shimonishi et al., 1992; Kuranuki & Yoshida, 1996) before immersion in LN. It is reported that the optimal moisture of the sample is 10%~30% for survival after cryopreservation in the dehydration method (Uragami et al., 1990; Shimonishi et al., 1992; Kuranuki and Yoshida, 1996). After the dehydration, germplasms are moved to a cryotube and immersed in LN. Cryopreserved tubes are warmed at room temperature or using hot

water (40 °C) for 1 ~ 2 min. After rewarming, samples are removed from the cryotube, and recultured.

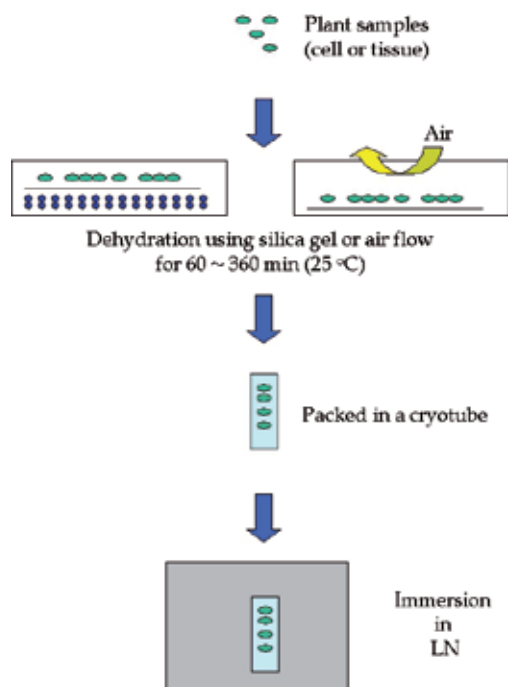

Fig. 6. The protocol of Dehydration method (from Uragami et al., 1990).

### 2.1.8 Encapsulation-dehydration

The encapsulation-dehydration method was first reported by Fabre & Dereuddre (1990) using shoot apices of potato, and spread worldwide the same way as vitrification and encapsulation-vitrification. This method excels that of dehydration in that regrowth of plant germplasm after cryopreservation is markedly increased by encapsulating plant samples with alginate beads. In addition, encapsulated samples are difficult to be crushed with tweezers compared with the dehydration method.

The encapsulation-dehydration procedure is shown in Fig. 7. Plant tissues are immersed in a calcium-free liquid medium supplemented with 0.4 mol/L sucrose and 30.0 g/L sodium alginate. The mixture (including a plant cell or tissue) was added drop by drop to the liquid medium containing 0.1 mol/L calcium chloride, forming beads about 5 mm in diameter. The above-mentioned liquid mediums (30.0 g/L sodium alginate and 0.1 mol/L calcium chloride) were adjusted by pH 5.7~5.8, but without plant growth regulators. Encapsulated germplasms are added to the culture bottle containing LS for the osmoprotection. Beads in the bottles are osmoprotected for 16 hrs at room temperature (25 °C). LS is the liquid culture medium in which sucrose (0.75~0.8 mol/L) is contained. After loading, LS is removed from the bottle. Loaded samples are put on sterilized filter papers, and samples are dehydrated by silica gel for 3~7 hours before immersion in LN. After dehydration by silica gel, encapsulated samples are moved to a cryotube, and immersed in LN. Cryopreserved tubes are warmed using hot water (40 °C) for 1 ~ 2 min. After rewarming, samples are moved from the cryotube, and recultured.

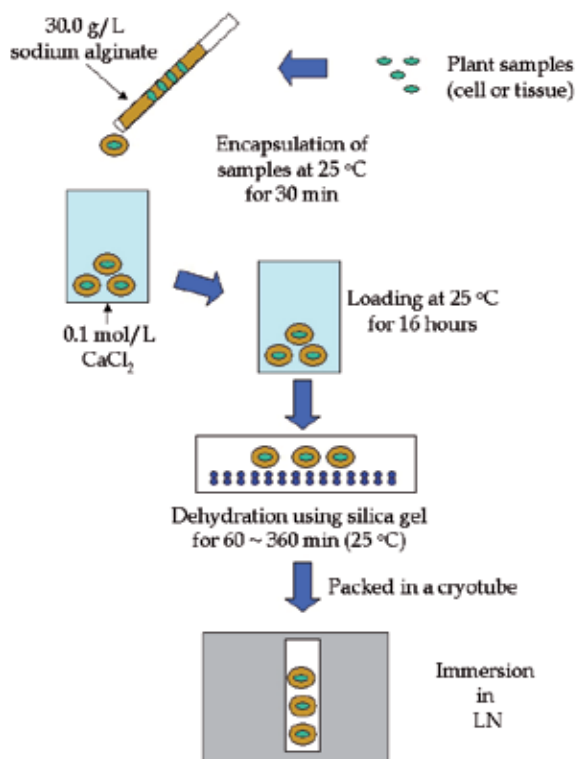

Fig. 7. The protocol of Encapsulation-dehydration method (from Fabre & Dereuddre, 1990).

In encapsulation-dehydration, the addition of glycerol besides sucrose in LS reportedly enhances the regrowth percentage of cryopreserved samples. The optimal concentration of glycerol in LS is 0.5~2.0 mol/L for regrowth of cryopreserved specimens (Matsumoto & Sakai, 1995; Kami et al., 2005, 2007, 2008).

### 2.1.9 Newly-developed encapsulation-dehydration

A newly developed encapsulation-dehydration method was first reported by Sakai et al. (2000). The operating procedure is the same as for encapsulation-dehydration (see Fig. 7), however, the LS composition differs. LS of the newly developed encapsulation-dehydration includes a high concentration (2.0 mol/L) of glycerol besides sucrose. Therefore, the loading time of this method (1 hour) is shorter than that of encapsulation-dehydration (16 hours).

## 2.2 Methods of improvement of cryopreservation efficiency

In this section, I introduce some approaches to increase regrowth of samples after rewarming with past reports and actual experimental data I obtained.

### 2.2.1 Plant material

Before performing cryopreservation of plant samples, it is necessary to grasp the characteristics of the given plant species. For example, it is better to utilize encapsulation-

dehydration rather than vitrification for plant species which are subject to toxicity from cryoprotectants. Moreover, if you want to cryopreserve the plant germplasms readily susceptible to toxicity in DMSO with the vitrification method, it is better to use PVS3 rather than PVS2 as the vitrification solution.

Next, I would like to explain this paragraph with actual experimental data I obtained. In cryopreservation, the extracted size of plant material also becomes important. When plant tissues are greatly (3 mm x 3 mm) trimmed, the extraction labor will decline with small tissue size (1 mm x 1 mm). However, the regrowth percentage of large tissues after cryopreservation seems to decrease more than that of small tissues (Fig. 8; Kami et al., 2010). From previous reports, the reason is that the smaller the size of the extracted plant, the more the osmosis cryoprotectant decreases (Kim et al., 2004, 2005).

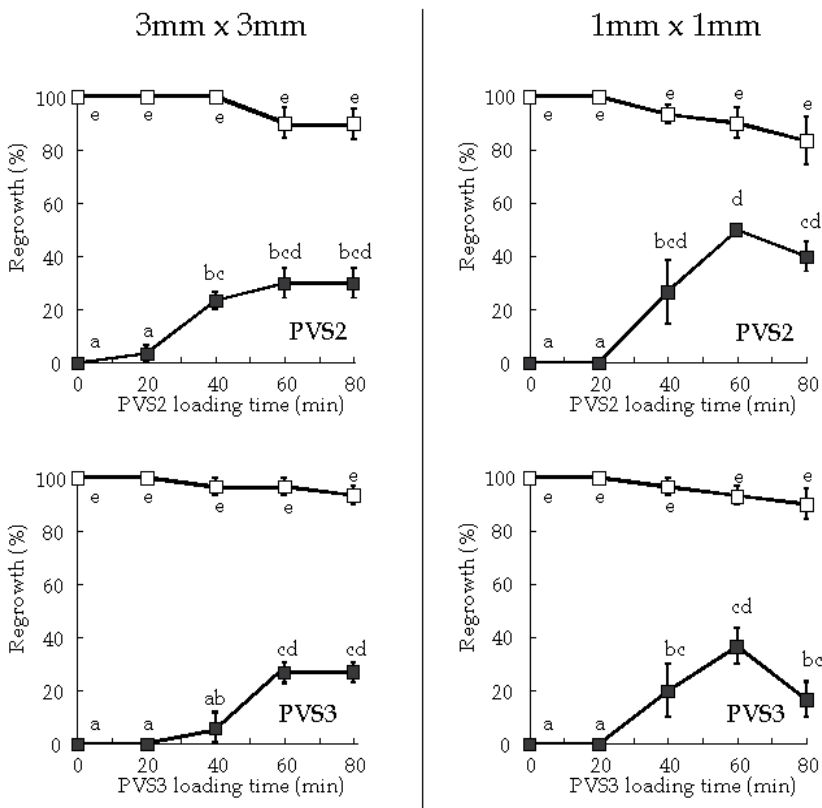

Fig. 8. Effects of excised apex size and exposure time to plant vitrification solution (PVS) on the regrowth of shoot apices immersed in liquid nitrogen (LN) using vitrification. Apices were dehydrated with two types of PVS at 0 °C for various lengths of time prior to cooling (Cryopreserved) or without cooling to -196 °C (Treated Control). The PVS in a cryovial was exchanged just after PVS loading treatment to prevent deterioration of PVS by a loading solution in this study. After cooling for 1hour in LN, rewarming apices were transplanted into regrowth medium. Values represent mean  $\pm$  SE of three determinations. Differences in mean values of regrowth of treated control and cryopreserved apices with different letters are statistically significant (Tukey's HSD at  $p < 0.05$ ) in all data. (from Kami et al., 2010)

### 2.2.2 Treatment before cryopreservation

Before cryopreservation, cold-acclimation and preculture are done, so survival percentages will increase after cryopreservation.

Cold-acclimation is a treatment by which plantlets are cultured at about 5 °C for one week to two months. However, Chang et al. (2000) reported that cold-acclimation was performed at -1 °C in grass species (*Zoysia* and *Lolium* sp.). The freezing resistance of plant specimens reportedly increases by cold-acclimation (Chang et al., 2000). However, since cold-acclimation cannot be adapted for a tropical plant, you should not perform this operation. Moreover, optimal acclimation periods differ by plant germplasms. In addition, prolonged cold-acclimation may curve and lower the survival percentage of plant specimens after cryopreservation. Therefore, I recommend that you closely consider the optimal cold acclimation period before trying cryopreservation.

Preculture is the treatment which gives plant cells or tissues dehydration tolerance. In many cases, plant samples are cultivated for 24~48 hours by culture medium supplemented with high-concentration the sucrose (0.3~0.7 mol/L). And some plant species are moved gradually from low to high concentration of sucrose medium (Niino et al., 1992; Niino & Sakai, 1992a,b; Suzuki et al., 1994; Niino et al., 1997). In addition, there are also cases in which glycerol (Matsumoto et al., 1998; Niino et al., 2003), DMSO (Fukai, 1990), or abscisic acid (ABA; Kendal et al., 1993; Tsukazaki et al., 2000) is mixed with a sucrose culture medium, and culture medium containing sorbitol without sucrose are used (Yamada et al., 1991; Maruyama et al., 2000). In many cases, room temperature is used for treatment (20~25 °C). However, some plant species can be processed by -1 °C (Chang et al., 2000) or 5 °C (Niino & Sakai, 1992a,b; Kuranuki & Sakai, 1995; Tanaka et al., 2004).

### 2.2.3 Treatment under cryopreservation

I would like to explain this paragraph with actual experimental data I obtained. In vitrification, I examined the effect of exchange times of fresh PVS2 during a 60-min PVS2 loading treatment on shoot apices (*Cardamine yezoensis* Maxim.) immersed in LN using a vitrification protocol (Fig. 9). The shoot regeneration percentages after cryopreservation was enhanced up to 96.7% when two PVS2 exchanges were used. Moreover, above 80% of shoot regrowth was maintained also by three or more PVS2 exchanges. From this experiment, it became clear that the injury by too much dehydration and medical toxicity are not induced by the exchange of fresh vitrification solution. However, the increase in the exchange time of vitrification solution carries a complex risk of losing the shoot apex and operating. Therefore, I considered that even 2 exchanges during 60-min PVS2 loading treatment on shoot apices of *Cardamine yezoensis* was appropriate (Kami et al., 2010).

Since PVS2 at 0 °C has high viscosity and the circulation in the cryobial is poor, it is thought PVS2 around a shoot apex was diluted by the moisture flowing out of the plant tissue. Therefore, by exchanging for fresh PVS2, the dilution of PVS2 around a shoot apex was prevented and the dehydration maintained.

Furthermore, adding an ice blocking agent to PVS reportedly enhances regeneration of cryopreserved sample in recent years (Zhao et al., 2005).

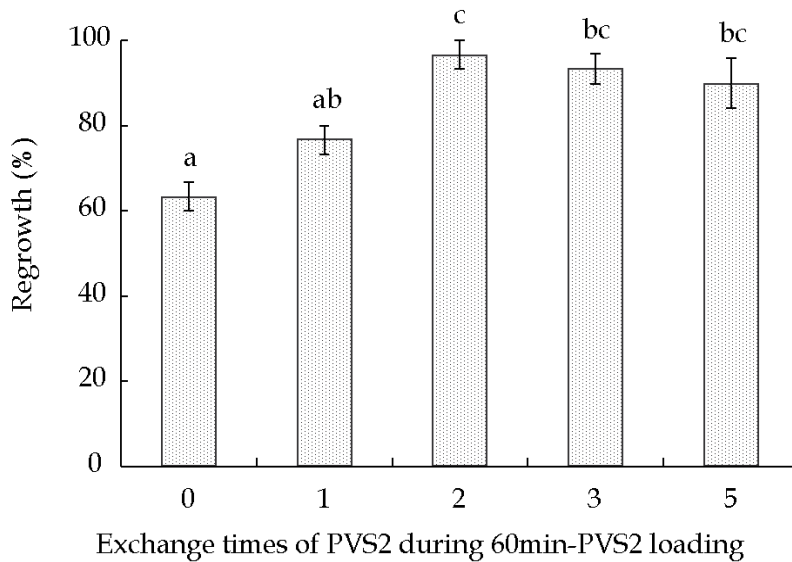

Fig. 9. Effects of exchange times of PVS2 during 60-min PVS2 loading treatment on shoot apices immersed in LN using vitrification. 2 ml of fresh PVS2 were exchanged at 0°C for 60-mins prior to cooling. A PVS2 exchange just after PVS2 loading treatment was not counted as the exchanging time of PVS2 in this study. After cooling for 1hour in LN, rewarming apices were transplanted into 1/4MS. Values represent mean  $\pm$  SE of three determinations. Differences in mean values of regrowth with different letters are statistically significant (Tukey's HSD at  $p < 0.05$ ) in each treatments. (from Kami et al., 2010)

#### 2.2.4 Treatment after cryopreservation

In cryopreservation of plant genetic resources, regeneration after rewarming is the key. Surviving cells or tissues after cryopreservation readily succumb due to different environmental agents because they have been injured by the dehydration or temperature change during the cryopreservation procedure. Moreover, when plant specimens were injured by the cryopreservation process, polyphenol can be produced. Thus, this may threaten the survival of plant specimens after cryopreservation. In that case, regeneration of tissues after preservation reportedly increased when activated charcoal (Bagniol & Engelmann, 1992) and polyvinyl pyrrolidone (Niino et al., 2003), an adsorbent of polyphenol, was mixed with a culture medium.

In recent years, it is also reported that regrowth percentages of rewarming tissues increased by mixing surfactant with regrowth medium (Anthony et al., 1996; Niu et al., 2010). Therefore, special consideration must be given to certain plant species. From previous reports, the regrowth after preservation increases sharply also by decreasing  $\text{NH}_4^+$  concentration in a culture medium (Niino et al., 1992a, 1992b; Suzuki et al., 1994; Pennycooke & Towill, 2001).

Next, I would like to explain this paragraph with actual experimental data I obtained. I examined the effects of various nutrient media (Table 2) on regrowth of cryopreserved

apices (*Cardamine yezoensis* Maxim.). It was demonstrated that 4-fold dilution of inorganic salts of Murashige and Skoog's medium (1/4MS) or Woody Plant medium (WPM) as basal medium resulted in higher regrowth percentages (both 66.7%) than six other media (Fig. 10; Kami et al., 2010).

Component (mmol/L)	Murashige & Skoog (MS)				White	B5	N6	WPM
	1	1/2	1/4	1/8				
NO <sub>3</sub> <sup>-</sup>	45.39	22.70	11.35	5.67	0.79	26.77	30.25	6.30
NH <sub>4</sub> <sup>+</sup>	20.61	10.31	5.15	2.58	0.00	2.33	7.01	5.00
PO <sub>4</sub> <sup>3-</sup>	1.25	0.62	0.31	0.16	0.12	1.09	2.94	1.25
K <sup>+</sup>	20.05	10.02	5.01	2.51	1.63	24.73	30.94	12.61
Ca <sup>2+</sup>	2.99	1.50	0.75	0.37	1.27	1.02	1.13	3.01
Mg <sup>2+</sup>	3.07	3.07	0.77	0.28	5.98	2.08	1.54	3.07

Table 2. Compositions of eight types of nutrient medium for the regrowth of cryopreserved shoot apices

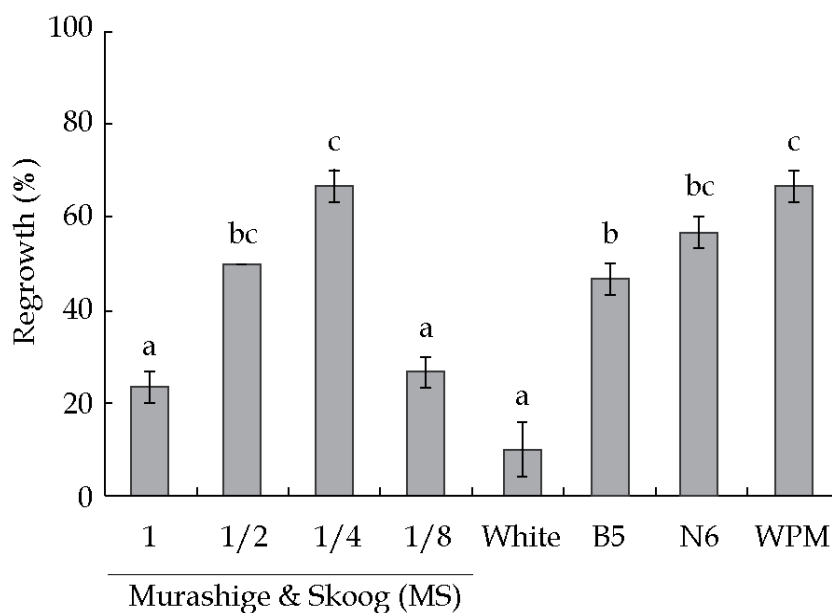

#### Nutrient media used for regrowth of cryopreserved apices

Fig. 10. Effects of nutrient media on the regrowth of shoot apices immersed in LN using vitrification. Apices were dehydrated with PVS2 at 0°C for 60-mins prior to immersion in LN. The PVS2 in a cryovial was exchanged once just after PVS2 loading treatment. After cooling for 1hour in LN, rewarming apices were transplanted into 8 types of basal medium. Values represent mean  $\pm$  SE of three determinations. Differences in mean values of regrowth with different letters are statistically significant (Tukey's HSD at  $p < 0.05$ ) in each treatments. (from Kami et al., 2010)

### 3. Conclusion

The cryopreservation technique for plant genetic resources has developed since the 1990s. However, since there are plant species which cannot yet be cryopreserved, improvement of the technology is a pressing need. I have limited my remarks to the introduction of the cryopreservation technique in this section. This seems like a personal comment, not a part of your conclusion. Kartha (1985), in his detailed book on these principles, provides a valuable addition to this chapter, not but provides an explanation of cryopreservation technology.

### 4. References

- Anthony, P.; Jerodar, N.B., Lowe, K.C., Power, J.B. & Davey, M.R. (1996). Pluronic F-68 increases the post-thaw growth of cryopreserved plant cells. *Cryobiology*, Vol.33, No.6, (July 1996), pp.508-514, ISSN 0011-2240
- Bagniol, S. & Engelmann, F. (1992). Effect of thawing and recovery conditions on the regrowth of meristems of date palm (*Phoenix dactylifera* L.) after cryopreservation in liquid nitrogen. *Cryo-Letters*, Vol.13, No.3, (January 1992), pp. 253-260, ISSN 0143-2044
- Bajaj, Y.P.S. (1995). *Biotechnology Agriculture and Forestry 32 - Cryopreservation of Plant Germplasm I*, Springer-Verlag, ISBN 3-540-57451-4, Berlin Heidelberg, German
- Chang, Y.J.; Baker, R.E. & Reed, B.M. (2000). Cold acclimation improves recovery of cryopreserved grass (*Zoysia* and *Lolium* sp.). *Cryo-Letters*, Vol.21, No.2, (November 1999), pp. 107-116, ISSN 0143-2044
- Fabre, J. & Dereuddre, J. (1990). Encapsulation Dehydration - A new approach to cryopreservation of *Solanum* shoot-tips. *Cryo-Letters*, Vol.11, No.5, (April 1990), pp. 413-426, ISSN 0143-2044
- Finkle, B.J. & Ulrich, J.M. (1979). Effects of cryoprotectants in combination on the survival of frozen sugarcane cells. *Plant Physiology*, Vol.63, No.4, (November 1978), pp. 598-604, ISSN 0032-0889
- Fukai, S. (1990). Cryopreservation of chrysanthemum shoot tips. *Scientia Horticulturae*, Vol.45, No.2, (December 1989), pp. 167-174, ISSN0304-4238
- Grout, B.W.W. & Henshaw, G.G. (1980). Structural observations on the growth of potato shoot-tip cultures after thawing from liquid nitrogen. *Annals of Botany*, Vol.46, No.2, (January 1980), pp. 243-248, ISSN 0305-7364
- Haskins, R.H. & Kartha, K. K. (1980). Freeze preservation of pea meristems: cell survival. *Canadian Journal of Botany*, Vol.58, No.8, (May 1980), pp. 833-840, ISSN 0008-4026
- Hirai, D. & Sakai, A. (1999). Cryopreservation of *in vitro*-grown axillary shoot-tip maristems of mint (*Mentha spicata* L.) by encapsulation-vitrification. *Plant Cell Reports*, Vol.19, No.2, (February 1999), pp. 150-155, ISSN 0721-7714
- Hirai, D. & Sakai, A. (2002). Simplified cryopreservation of sweet potato (*Ipomoea batatas* (L.) Lam.) by optimizing conditions for osmoprotection. *Plant Cell Reports*, Vol.21, No.10, (February 2002), pp. 961-966, ISSN 0721-7714
- Kami, D.; Suzuki, T. & Oosawa, K. (2005). Cryopreservation of blue honeysuckle *in vitro*-cultured tissues using encapsulation-dehydration and vitrification. *Cryobiology and Cryotechnology*, Vol.51, No.2, (December 2005), pp.63-68, ISSN 1340-7902



- Kami, D.; Uenohata, M., Suzuki, T. & Oosawa, K. (2008). Cryopreservation of black chokeberry *in vitro* shoot apices. *Cryo-Letters*, Vol.29, No.3, pp.209-216, (January 2008), ISSN 0143-2044
- Kami, D.; Shi, L., Sato, T., Suzuki, T. & Oosawa, K. (2009). Cryopreservation of shoot apices of hawthorn *in vitro* cultures originating from East Asia. *Scientia Horticulturae*, Vol.120, No.2, (August 2008), pp. 84-88, ISSN0304-4238
- Kami, D.; Kido, S., Otokita, K., Suzuki, T., Sugiyama, K. & Suzuki, M. (2010). Cryopreservation of shoot apices of *Cardamine yezoensis* *in vitro*-cultures by vitrification Method. *Cryobiology and Cryotechnology*, Vol.56, No.2, (September 2010), pp.119-126, ISSN 1340-7902 (in Japanese with English summary)
- Kartha, K.K. (1985). *Cryopreservation of Plant Cells and Organs*, CRC Press, ISBN 0-8493-6102-8, Florida, U.S.A.
- Kendall, E.J.; Kartha, K.K., Qureshi, J.A. & Chermak, P. (1993). Cryopreservation of immature spring wheat zygotic embryos using an abscisic acid pretreatment. . *Plant Cell Reports*, Vol.12, No.2, (October 1992), pp. 89-94, ISSN 0721-7714
- Kim, H.H.; Kim, J.B., Baek, H.J., Cho, E.G., Chae, Y.A. & Engelmann, F. (2004). Evolution of DMSO concentration in garlic shoot tips during a vitrification procedure, *Cryo-Letters*, Vol.25, No.1, (October 2003), pp. 91-100, ISSN 0143-2044
- Kim, J.B.; Kim, H.H., Baek, H.J., Cho, E.G., Kim, Y.H. & Engelmann, F. (2005). Changes in sucrose and glycerol content in garlic shoot tips during freezing using PVS3 solution, *Cryo-Letters*, Vol.26, No.2, (December 2004), pp. 103-112, ISSN 0143-2044
- Kobayashi, T.; Niino, T. & Kobayashi, M. (2005). Simple cryopreservation protocol with an encapsulation technique for tobacco BY-2 suspension cell cultures. *Plant Biotechnology*, Vol.22, No.2, (March 2005), 105-112, ISSN 1342-4580
- Kumu, Y.; Harada, T. & Yakuwa, T. (1983). Development of a whole plant from a shoot tip of *Asparagus officinalis* L. frozen to -196°C. *Journal of the Faculty of Agriculture, Hokkaido University*, Vol.61, No.3, (May 1983), pp. 285-294, ISSN 0018-344X
- Kuranuki, Y. & Sakai, A. (1995). Cryopreservation of *in vitro*-grown shoot tips of tea (*Camellia sinensis*) by vitrification. *Cryo-Letters*, Vol.16, No.4, (April 1995), pp. 345-352, ISSN 0143-2044
- Kuranuki, Y. & Yoshida, S. (1996). Differential responses of embryogenic axes and cotyledons from tea seeds to desiccation and cryoexposure. *Breeding Science*, Vol. 46, No.2, pp. 149-154, (March 1996), ISSN 1347-3735
- Leunufna, S. & Keller, E.R.J. (2003). Investigating a new cryopreservation protocol for yams (*Discorea* spp.). *Plant Cell Reports*, Vol.21, No.12, (April 2003), pp. 1159-1166, ISSN 0721-7714
- Maruyama, E., Tanaka, T., Hosoi, Y., Ishii, K. & Morohoshi, N. (2000). Embryogenic cell culture, protoplast regeneration, cryopreservation, biolistic gene transfer and plant regeneration in Japanese cedar (*Cryptomeria japonica* D. Don). *Plant Biotechnology*, Vol.17, No.4, (April 2000), 281-296, ISSN 1342-4580
- Matsumoto, T.; Sakai, A., Takahashi, C. & Yamada, K. (1995). Cryopreservation of *in vitro*-grown apical meristems of wasabi (*Wasabia japonica*) by encapsulation-vitrification method. *Cryo-Letters*, Vol.16, No.2, (November 1994), pp. 189-196, ISSN 0143-2044

- Matsumoto, T. and A. Sakai. 1995. An approach to enhance dehydration tolerance of alginate-coated dried meristems cooled to  $-196^{\circ}\text{C}$ . *Cryo-Letters*, Vol.16, No.3, (January 1995), pp. 299-306, ISSN 0143-2044
- Matsumoto, T.; (1998). A novel preculturing for enhancing the survival of *in vitro*-grown meristems of wasabi (*Wasabia japonica*) cooled to  $-196^{\circ}\text{C}$  by vitrification. *Cryo-Letters*, Vol.19, No.1, (September 1997), pp. 27-36, ISSN 0143-2044
- Niino, T. & Sakai, A. (1992a). Cryopreservation of alginate-coated *in vitro*-grown shoot tips of apple, pear and mulberry. *Plant Science*, Vol.87, No.2, (August 1992), pp. 199-206, ISSN 0168-9452
- Niino, T. & Sakai, A. (1992b). Cryopreservation of *in vitro*-grown shoot tips of apple and pear by vitrification. *Plant Cell, Tissue and Organ Culture*. Vol.28, No.3, (October 1991), pp. 261-266, ISSN 0167-6857
- Niino, T.; Sakai, A., Yakuwa, H. & Nojiri, K. (1992). Cryopreservation of *in vitro*-grown shoot tips of mulberry by vitrification. *Cryo-Letters*, Vol.13, No.4, (April 1992), pp. 303-312, ISSN 0143-2044
- Niino, T.; Tashiro, K., Suzuki M., Ochiai, S., Magoshi, J. & Akihama, T. (1997). Cryopreservation of *in vitro*-grown shoot tips of cherry and sweet cherry by one-step vitrification. *Scientia Horticulturae*, Vol.70, No.2, (March 1997), pp. 155-163, ISSN0304-4238
- Niino, T.; Tanaka, D., Ichikawa, S., Takano, J., Ivette, S., Shirata, K. & Uemura, M. (2003). Cryopreservation of *in vitro*-grown apical shoot tips of strawberry by vitrification. *Plant Biotechnology*, Vol.20, No.1, (November 2002), 75-80, ISSN 1342-4580
- Nishizawa, S.; Sakai, A., Amano, Y. & Matsuzawa, T. (1993). Cryopreservation of asparagus (*Asparagus officinalis* L.) embryogenic suspension cells and subsequent plant regeneration by vitrification. *Plant Science*, Vol.91, No.1, (March 1993), pp. 67-73, ISSN 0168-9452
- Niu, Y.L.; Zhang, Y.F., Zhang, Q.L. & Luo, Z.R. (2010). A preliminary study on cryopreservation protocol applicable to all types of *Diospyros Kaki* Thunb. *Biotechnology & Biotechnological Equipment*, Vol.24, No.3, (April 2010), pp. 1960-1964, ISSN 1310-2818
- Panis, B.; Piette, B. & Swennen, R. (2005). Droplet vitrification of apical meristems: a cryopreservation protocol applicable to all Musaceae. *Plant Science*, Vol.168, No.1, (July 2004), pp. 45-55, ISSN 0168-9452
- Pennycooke, J.C. & Towill, L.E. (2000). Cryopreservation of shoot tips from *in vitro* plants of sweet potato [*Ipomoea batatas* (L.) Lam.] by vitrification. *Plant Cell Reports*, Vol.19 No. 8, (September 1999), pp. 733-737, ISSN 0721-7714
- Pennycooke, J.C. & Towill, L.E. (2001). Medium alternations improve regrowth of sweet potato (*Ipomoea batatas* {L.} Lam.) shoot tips cryopreserved by vitrification and encapsulation-dehydration. *Cryo-Letters* Vol.22, No.4, (February 2001), pp. 381-389, ISSN 0143-2044
- Sakai, A.; Kobayashi, S. & Oiyama, I. (1990). Cryopreservatioin of nucellar cells of navel orange (*Citrus sinensis* Osb. var *Brasiliensis* Tanaka) by vitrification. *Plant Cell Reports*, Vol.9, No.1, (January 1990), pp. 30-33, ISSN 0721-7714

- Sakai, A.; Kobayashi, S. & Oiyama, I. (1991). Cryopreservatioin of nucellar cells of navel orange (*Citrus sinensis* Osb. var *Brasiliensis* Tanaka) by a simple freezing method. *Plant Science*, Vol.74, No.3, (October 1990), pp. 243-248, ISSN 0168-9452
- Sakai, A.; Matsumoto, T., Hirai, D. & Niino, T. (2000). Newly developed encapsulation-dehydration protocol for plant cryopreservation. *Cryo-Letters*, Vol.21, No.1, (October 1999), pp. 53-62, ISSN 0143-2044
- Schäfer-Menuhr, A.; Schumacher, H.M. & Mix-Wagner, G. (1994). Langzeitlagerung alter Kartoffelsorten durch Kryokonservierung der Meristeme in flüssigem Stickstoff. *Landbauforschung Völkenrode*, Vol.44, No.4, (March 1994), pp. 301-313, ISSN 0376-0723 (in German with English summary)
- Schäfer-Menuhr, A.; Schumacher, H.M. & Mix-Wagner, G. (1997). Long-term storage of old potato varieties by cryopreservation of shoot-tips in liquid nitrogen. *Plant Genetic Resources Newsletter*, (October 1998), Vol.111, No.1, pp. 19-24, ISSN 1020-3362
- Shimonishi, M.; Ishikawa, M., Suzuki, S. & Oosawa, K. (1991). Cryopreservation of melon somatic embryos by desiccation method. *Japanese Journal of Breeding*, Vol.41, No.2, (January 1991), 347-351, ISSN 0536-3683
- Sugawara, Y. & Sakai, A. (1974). Survival of suspension-cultured sycamore cells cooled to the temperature of liquid nitrogen. *Plant Physiology*, Vol.74, No.5, (August 1974), pp. 722-724, ISSN 0032-0889
- Suzuki, M.; Niino, T. & Akihama, T. (1994). Cryopreservation of shoot tips of kiwifruit seedlings by the alginate encapsulation-dehydration technique. *Plant Tissue Culture Letters*, Vol.11, No2., pp. 122-128, (November 1993), ISSN 0289-5773
- Tanaka, D.; Niino, T., Isuzugawa, K., Hikage, T. & Uemura, M. (2004). Cryopreservation of shoot apices of *in-vitro* grown gentian plants: comparison of vitrification and encapsulation-vitrification protocols. *Cryo-Letters*, Vol.25, No.3, (January 2004), pp. 167-176, ISSN 0143-2044
- Tsukazaki, H.; Mii, M., Tokuhara, K. & Ishikawa, K. (2000). Cryopreservation of *Doritaenopsis* suspension culture by vitrification. *Plant Cell Reports*, Vol.19, No.12, (June 2000), pp. 1160-1164, ISSN 0721-7714
- Towill, L.E. & Bajaj, Y.P.S. (2002). *Biotechnology Agriculture and Forestry 50 – Cryopreservation of Plant Germplasm II*, Springer-Verlag, ISBN 3-540-41676-5, Berlin Heidelberg, German
- Uemura, M. & Sakai, A. (1980). Survival of carnation (*Dianthus caryophyllus* L.) shoot apices frozen to the temperature of liquid nitrogen. *Plant & Cell Physiology*, Vol.21, No.1, (September 1979), pp. 85-94, ISSN 1471-9053
- Uragami, A.; Sakai, A., Nagai, M. & Takahashi, T. (1989). Survival of cultured cells and somatic embryos of *Asparagus officinalis* cryopreserved by vitrification. *Plant Cell Reports*, Vol.8, No.5, (August 1989), pp. 418-421, ISSN 0721-7714
- Uragami, A.; Sakai, A. & Nagai, M. (1990). Cryopreservation of dried axillary buds from plantlets of *Asparagus officinalis* L. grown *in vitro*. *Plant Cell Reports*. Vol.9, No.4, pp. 328-331, (August 1990), ISSN 0721-7714

- Yamada, T.; Sakai, A., Matsumura, T. & Higuchi, S. (1991). Cryopreservation of apical meristems of white clover (*Trifolium repens* L.) by vitrification. *Plant Science* Vol.78, No.1, (September 1990), pp. 81-87, ISSN 0168-9452
- Zhao, M.A.; Xhu, Y.Z., Dhital, S.P., Song, Y.S., Wang, M.Y. & Lim, H.T. (2005). Anefficient cryopreservation procedure for potato (*Solanum tuberosum* L.) utilizing the new ice blocking agent, Supercool X1000. *Plant Cell Reports*. Vol.24, No.5, (April 2005), pp. 477-481, ISSN 0721-7714

# Cryopreservation of Spices Genetic Resources

K. Nirmal Babu<sup>1</sup>, G. Yamuna<sup>1</sup>, K. Praveen<sup>1</sup>, D. Minoo<sup>2</sup>,  
P.N. Ravindran<sup>1</sup> and K.V. Peter<sup>1</sup>

<sup>1</sup>Indian Institute of Spices Research, Kerala

<sup>2</sup>Providence Women's College, Kerala  
India

## 1. Introduction

Plant genetic resources - constituting genotypes or populations of cultivars (landraces, advance/improved cultivars), genetic stocks, wild and weedy species, which are maintained in the form of plants, seeds, tissues, etc. - hold key to food security and sustainable agricultural development (Iwananga, 1994). They are non-renewable and are among the most essential of the world's natural resources. Due to deforestation, spread of superior varieties and selection pressure, genetic variability is gradually getting eroded. This demands priority action to conserve germplasm be it at species, genepool or ecosystem level, for posterity (Frankel, 1975).

Whilst ecologists focused on *in situ* conservation might argue that *ex situ* conserved germplasm cannot offer the advantages afforded by selection and adaptation as a result of environmental pressures, there is no denying that if species are under threat—or worse, near extinction—then *ex situ* conservation of even limited germplasm is preferable to extinction. The opportunities offered by conservation biotechnology should not be missed or restricted by lack of interconnectivity between traditional and contemporary conservation practitioners.

## 2. Spices and germplasm conservation

Spices and herbs are aromatic plants—fresh or dried plant parts like foliage, young shoots, roots, bark, buds, seeds, berries and other fruits of which are mainly used to flavour our culinary preparations, confectionary. They are also major ingredients in indigenous medicine and perfumery. Spices and herbs are grown throughout the world—different plant species in different regions. Peninsular India is a rich repository of spices and over 100 species of spices and herbs are grown. The other major spice growing countries are Brazil, China, Guatemala, Indonesia, Madagascar, Nigeria, West Indies, Malaysia, Sri Lanka, Spain, Turkey, Mediterranean region and the Central America. Black pepper, cardamom, ginger, turmeric, vanilla, capsicum, cinnamon, clove, nutmeg, tamarind, coriander, cumin, fennel, fenugreek, dill, caraway, anise and herbs like saffron, lavender, thyme, oregano, celery, anise, sage and basil are important as spices. India being the native home of many spices, their conservation and characterization are one of the priority programmes. Deforestation, habitat degradation and overexploitation caused considerable loss of diversity in spices.

In many spices, conventional seed storage can satisfy most of the conservation requirements. But in crops with recalcitrant seeds and those having conservation needs cannot be satisfied by seed storage, have to be stored *in vitro*. Most field gene banks are prone to high labour cost, vulnerable to hazards like natural disasters, pests and pathogens attack (especially viruses and systemic pathogens), to which they are continuously exposed and require large areas of space. This supports *in vitro* and cryo conservation. In addition, other resources like continuous supply of standard stock cultures for experiments to examine physiological and biochemical processes, cell and callus lines developed for *in vitro* synthesis of valuable secondary products, flavours and other important compounds will benefit strongly from *in vitro* cultures. Most of the spice crops are either vegetatively propagated or have recalcitrant seeds. The spices germplasm is mostly conserved in field gene banks. Most of the spices are plagued by destructive and epidemic diseases caused by viruses, bacteria and fungi. This makes germplasm conservation in field gene bank risky. Thus *in vitro* and cryo storage system becomes important in the overall strategy of conserving genepool. Each technology should be chosen on the basis of utility, security and complementarily to other components of the strategy. A balance needs to be struck between seed, field gene bank, *in vitro* and cryo conservation of propagules, tissues, pollen, cell lines and DNA storage for overall objective of conserving gene pool.

### 3. Methodologies

#### 3.1 Micropropagation

Plant regeneration and successful cloning of genetically stable plantlets in tissue culture is an important pre-requisite in any conservation effort of recalcitrant species. These techniques form the base for establishing tissue cultures and developing *in vitro* and cryo conservation technology for conservation. Simultaneously these tissue-cultured plants should be evaluated for their morphological and genetic stability in culture. The *in vitro* storage experiments, as much as possible, use growth regulators free media to reduce the rate of multiplication which in turn will reduce the extent of variation.

Micropropagation (culture initiation, multiplication, plant regeneration and *in vitro* rooting) form the cycle of events that form the backbone of cryopreservation studies. For initial culture establishment earlier protocols developed by Nirmal Babu *et al.*, 1997 can be used.

Murashige and Skoog (1962), Woody Plant (McCown and Amos, 1979) and Schenk and Hildebrandt (1972) media can be used depending upon the crop for micropropagation Table 1. The miniaturized *in vitro* grown shoots can be used for cryopreservation.

Micropropagation protocols for stable cloning of elite genotypes of spice crops were standardised. Protocols were available for black pepper and its related species cardamom, ginger, turmeric and related genera, large cardamom, kasturi turmeric, mango ginger, *Kaempferia galanga*, *K. rotunda*, *Alpinia* spp, large. Cardamom, vanilla and related species, cinnamon, camphor, cassia seed and herbal spices like lavender, celery, thyme, mint, anise, savory, spearmint and oregano (Nirmal Babu *et al.*, 1997, 2005, Mino 2002). These techniques form the base for establishing tissue cultures and developing *in vitro* technology for conservation. The basal media used are MS (Murshige and Skoog, 1962) for crops like cardamom, ginger, turmeric, kasturi turmeric, mango ginger, large cardamom, *Kaempferia*, *Vanilla* spp. seed and herbal spices and WPM-Woody Plant Medium (Mc Cown and Amos,

1979) for black pepper and its related species, cinnamon, camphor and cassia. Simultaneously these tissue-cultured plants are being evaluated for their morphological and genetic stability in culture (Luckose *et al*, 1993, Chandrappa *et al*, 1997, Nirmal babu *et al* 2003, Madhusoodanan *et al* 2005). Though micropropagation protocols were standardized using growth regulators, all the *in vitro* storage experiments were carried out using growth regulators free media to reduce the rate of multiplication which in turn will reduce the extent of variation.

Composition	Molecular formula	Concentration (mg l <sup>-1</sup> ) MS	Concentration (mg l <sup>-1</sup> ) WPM	Concentration (mg l <sup>-1</sup> ) SH
<b>Macronutrients</b>				
Ammonium nitrate	NH <sub>4</sub> NO <sub>3</sub>	1650.00	400.00	-
Ammonium phosphate	NH <sub>4</sub> H <sub>2</sub> PO <sub>4</sub>	-	-	300.00
Potassium nitrate	KNO <sub>3</sub>	1900.00	-	2500.00
Calcium chloride	CaCl <sub>2</sub> .2H <sub>2</sub> O	440.00	-	-
Calcium chloride	CaCl <sub>2</sub>	-	72.50	151.00
Calcium nitrate	Ca(NO <sub>3</sub> ) <sub>2</sub> .4H <sub>2</sub> O	-	386.00	-
Potassium di hydrogen orthophosphate	KH <sub>2</sub> PO <sub>4</sub>	170.00	170.00	-
Potassium sulfate	K <sub>2</sub> SO <sub>4</sub>	-	990.00	-
Magnesium sulphate	MgSO <sub>4</sub> .7H <sub>2</sub> O	370.00	180.70	195.40
<b>Micronutrients</b>				
Sodium EDTA	Na <sub>2</sub> EDTA	37.30	37.30	20.00
Ferrous sulphate	FeSO <sub>4</sub> .7H <sub>2</sub> O	27.80	27.800	15.00
Boric acid	H <sub>3</sub> BO <sub>3</sub>	6.20	6.20	5.00
Manganese sulphate	MnSO <sub>4</sub> .4H <sub>2</sub> O	22.30	22.30	10.00
Potassium iodide	KI	0.83	-	1.00
Zinc sulphate	ZnSO <sub>4</sub> .7H <sub>2</sub> O	8.60	8.60	1.00
Sodium molybdate	Na <sub>2</sub> MoO <sub>4</sub> .2H <sub>2</sub> O	0.25	0.25	0.10
Copper sulphate	CuSO <sub>4</sub> .5H <sub>2</sub> O	0.025	0.25	0.20
Cobalt chloride	CoCl <sub>2</sub> .6H <sub>2</sub> O	0.025	-	0.10
<b>Vitamins</b>				
Myo-inositol	C <sub>6</sub> H <sub>12</sub> O <sub>6</sub>	100.00	100.00	1000
Thiamine HCl	C <sub>12</sub> H <sub>17</sub> ClN <sub>4</sub> OS.HCl	0.10	0.50	100
Nicotinic acid	C <sub>6</sub> H <sub>5</sub> NO <sub>2</sub>	0.50	0.025	1.00
Pyridoxine HCl	C <sub>6</sub> H <sub>11</sub> NO <sub>3</sub> .HCl	0.50	0.025	1.00
<b>Amino acid</b>				
Glycine	C <sub>2</sub> H <sub>5</sub> NO <sub>2</sub>	2.00	1	-

\*Murashige and Skoog, 1962, McCown and Amos, 1979, Schenk and Hildebrandt 1972

Table 1. Composition of MS\*, WPM\* and SH\* basal media

Protocols are available for micropropagation and multiplication of many endangered species like *Piper hapnium*, *P. silent vallyensis*, *P.schmidtii*, *P. wightii*, *P. barberi*, *Vaniilla aphylla*, *V. pilifera*, *V. walkyrie*, *V. wightiana*, *K. rotunda* and *Alpinia galanga* are available (Peter *et al* 2002, Minoo 2002, Nirmal Babu *et al* 1999, 2005).

Bertaccini *et al* (2004), Du *et al* (2004) reported micropropagation and establishment of mite-brone virus-free garlic.

### 3.2 Callus and cell culture systems

Quatrano (1968) and Nag and Street (1973) reported the first successful experiments on cryopreservation of plant cells. Since then a large number of cell suspension and calli cultures have been successfully cryopreserved (Engelmann *et al* 1994). In general, callus cultures are more difficult to cryopreserve than cell suspensions, because of the relative volume of the callus, its slow growth rate and the cellular heterogeneity (Withers 1987). One successful cryopreservation procedure that is applicable to all different cell suspensions or calli cultures has not been developed yet. Research focuses on optimizing the factors on which successful cryopreservation of plant organs cells suspensions and calli depends, such as: (i) starting material, (ii) pretreatment, (iii) cryopreservation procedure, and (iv) post-thaw treatment.

Plant cells cultured *in vitro* produce wide range of primary and secondary metabolites of economic value. Production of phytochemicals from plant cell cultures has been presently used for pharmaceutical products. Production of flavour components and secondary metabolites *in vitro* using immobilised cells is an ideal system for spices crops. Production of saffron and capsaicin was reported using such system (Ravishankar *et al.*, 1988; 1993, Johnson *et al.*, 1996; Venkataraman and Ravishankar 1997). Johnson *et al* (1996) reported biotransformation of ferulic acid vanillamine to capsaicin and vanillin in immobilised cell cultures of *Capsicum frutescens*. Reports on the *in vitro* synthesis of crocin, picrocrocin and safranal from saffron stigma (Himeno and Sano, 1995) and colour components from cells derived from pistils (Hori *et al*, 1988) are available for further scaling up. Callus and cell cultures were established in nutmeg, clove, camphor, ginger, lavender, mint, thyme, celery etc. Cell immobilization techniques have been standardized in ginger, sage, anise and lavender (Ilahi and Jabeen, 1992; Ravindran *et al*, 1996; Sajina *et al*, 1997).

Studies on conservation of cell lines is yet to become popular in spices. Suspensions of embryogenic cell lines of fennel, conserved at 4 °C for up to 12 weeks produced normal plants upon transfer to normal laboratory conditions (Umetsu *et al*, 1995).

### 3.3 Somatic embryogenesis and plant regeneration

In black pepper primary embryogenic cultures can be established as per the method described by Nair and Dutta Gupta (2003). Culture the surface sterilized seeds on agar gelled full-strength, PGR-free SH (Schenk and Hildebrandt, 1972) medium containing 3.0% (W/V) sucrose under darkness. Primary somatic embryos (PEs) derived from micropylar tissues of germinating seeds after 90 days could be utilized for inducing secondary somatic embryogenic cultures.

Primary somatic embryo clumps having pre-globular to torpedo shaped embryos (5–6 visible embryos per seed) were carefully detached and inoculated on half strength PGR-free SH medium containing 1.5 % sucrose and gelled with 0.8% agar (Bacteriological grade, Hi-media). The pH of the medium was adjusted to 5.9 prior to autoclaving. Cultures were maintained at darkness at a temperature of 25±2°C. The culture conditions remained the same for all further experiments unless otherwise specified. While inoculating, the PEs were uniformly spread on the surface of the medium. Secondary embryogenic cultures were further maintained by subculturing on SH medium containing 1.5% sucrose at intervals of 20 d. The proliferating SEs were spread periodically on the surface of the medium, to facilitate proliferation.



### 3.4 Pollen storage

Pollen storage can be considerable value supplementing the germplasm conservation strategy by facilitating hybridisation between plants with different time of flowering and to transport pollen across the globe for various crop improvement programmes in addition to developing haploid or homozygous lines. No significant work was done in India, except a few initial reports.

The technique of pollen storage is comparable with that of seed storage, since pollen can be dried (less than 5% moisture content on a dry weight basis) and stored below 0°C. There are limited reports on the survival and fertilizing capacity of cryopreserved pollen more than five years old. Pollen might represent an interesting alternative for the long-term conservation of problematic species (IPGRI, 1996). However, pollen has a relatively short life compared with seeds (although this varies significantly among species) and viability testing can be time-consuming and uneconomical. Other disadvantages of pollen storage are the small amount produced by many species, the lack of transmission of organelle genomes via pollen, the loss of sex-linked genes in dioecious species and the general inability to regenerate into plants. Pollen, therefore, has been used to a limited extent in germplasm conservation (Hoekstra, 1995). An advantage is that pests and diseases are rarely transferred by pollen (excepting some virus diseases). This allows safe movement and exchange of germplasm as pollen.

### 3.5 Cryo preservation

For long-term conservation of the problem species, cryopreservation is the only method currently available. Dramatic progress has been made in recent years in the development of new cryopreservation techniques and cryopreservation protocols have been established for over 100 different plant species.

Cryopreservation is an attractive option for long-term storage. Liquid nitrogen (-196°C) is routinely used for cryogenic storage, since it is relatively cheap and safe, requires little maintenance and is widely available. Below -120°C the rate of chemical or biophysical reactions is too slow to cause biological deterioration (Kartha 1985). Only in the long term might there be a small risk of ionising radiation causing genetic changes in materials stored at cryogenic temperatures (Grout 1995).

An array of plant material could be considered for cryopreservation as dictated by the actual needs *vis-a-vis* preservation. These include meristems, cell, callus and protoplast cultures, somatic and zygotic embryos, anthers, pollen or microspores and whole seeds (Withers, 1985; Kartha, 1985).

Plant germplasm stored in liquid nitrogen (-196°C) does not undergo cellular divisions. In addition, metabolic and most physical processes are stopped at this temperature. As such, plants can be stored for very long time periods and both the problem of genetic instability and the risk of losing accessions due to contamination or human error during subculturing are overcome. Most cryopreservation endeavours deal with recalcitrant seeds, *in vitro* tissues from vegetatively propagated crops, species with a particular gene combination (elite genotypes) and dedifferentiated plant cell cultures. Care must be taken to avoid ice crystallisation during the freezing process, which otherwise would cause physical damage

to the tissues. The existing cryogenic strategies rely on air-drying, freeze dehydration, osmotic dehydration, addition of penetrating cryoprotective substances and adaptive metabolism (hardening), encapsulation, vitrification or combinations of these processes.

Cryopreservation methods have been developed for more than 80 different plant species in various forms like cell suspensions, calluses, apices, somatic and zygotic embryos (Kantha and Engelmann, 1994; Engelmann, 1997, 2000, Engelmann *et al* 1994, 1995). However, their routine utilisation is still restricted almost exclusively to the conservation of cell lines in research laboratories

For small volumes, long-term storage is practicable through storage of cultures in cryopreservation at ultra-low temperature, usually by using liquid nitrogen (-196°C). At this temperature all cellular divisions and metabolic processes are virtually halted and consequently, plant material can be indefinitely stored without alteration or modification.

The normal approach of tissue culture is to find a medium and set of conditions that favour the most rapid rate of growth with a subculture interval of 20 – 30 days. For cryopreservation storage biological materials are stored in liquid nitrogen for long term with out subculturing. Cryopreservation, i.e., the storage of biological material at ultra low temperature usually that of liquid nitrogen (-196°C) can be achieved by different techniques like direct freezing, encapsulation- dehydration, encapsulation- vitrification and vitrification.

### 3.5.1 Encapsulation - Dehydration

A simplified methodology for vitrification is given below (Yamuna 2007).

The *in vitro* plants already established were used as mother plants for source of explants. This in turn facilitates the reduction in size of the plantlets and smaller somatic embryos which made them suitable for cryopreservation.

1. Suspend *in vitro* grown shoots/ somatic embryos in MS basal medium supplemented with 4% (w/v) Na alginate, 2M Glycerol and 0.4 M sucrose.
2. Drop the mixture containing microshoots, with a sterile pipette into 0.1M CaCl<sub>2</sub> solution containing 2M Glycerol and 0.4M sucrose and left for 20 min to form beads about 4 mm in diameter, each bead containing at least one shoot.
3. Preculture the encapsulated shoots – stepwise - on MS medium enriched with different concentration of 0.3, 0.5, 0.75 and 1.0M for four days with one day on each.
4. Place the precultured beads on sterile filter paper in Petridishes (diameter 90mm) and dehydrated by air drying on a flow bench (at room temperature and humidity) for periods of 0-10 h to determine the optimal dehydration time.
5. Measure the water content of the beads was by weighing them prior and after drying in an oven at 80°C for 48h.
6. Transfer the dehydrated beads into a 2 ml cryovial (ten beads per tube) and directly immerse in liquid nitrogen for 24h.

### 3.5.2 Vitrification

A simplified methodology for vitrification is given below (Yamuna 2007).

1. Shoots (1-2mm)/ somatic embryos were excised and cultivated on MS medium supplemented with 0.3 M sucrose for 24h at 25°C.

2. The treated explants were then cultured on MS medium supplemented with sucrose at 0.75 M for 1 day in the same conditions.
3. After pretreatments explants were transferred to a cryovial with 1.8 ml of loading solution (2 M Glycerol + 0.4 M sucrose) and kept for 15 min.
4. Different incubation periods in PVS2 (40-100 minutes) were tested for osmoprotected explants
5. Cryovials containing 8-10 explants were directly immersed in liquid nitrogen and kept for 24 h.

### 3.5.3 Encapsulation – Vitrification

A simplified methodology for encapsulation - vitrification is given below (Yamuna 2007).

1. Suspend pre-cultured shoots (1-2mm)/ somatic embryos with 2-3 apical domes on 0.3M sucrose for 16h in MS basal medium supplemented with 4% sodium alginate and 0.3 M sucrose.
2. Dispense the mixture including shoots, were with a sterile pipette into MS medium supplemented with 0.1M CaCl<sub>2</sub> and 0.4 to 1.0M sucrose, with or without 2M Glycerol gently shaken (20 rpm) on a rotary shaker for 1h at 25°C.
3. The encapsulated and osmo-protected shoots were dehydrated with 20 ml PVS2 in a 100 ml Erlenmeyer flask at 25°C and plunged into LN and held for at least 24 h at -196°C.

### 3.6 Thawing and recovery of conserved materials

After LN storage, cryovials warm rapidly in a 40 °C water bath for 2-3 minutes. The solution was drained from the cryovials and replace twice at 10 min intervals with 1 ml 1.2 M sucrose solution in the case of encapsulation- vitrification and vitrification methods. The composition of recovery medium was MS/WPM/SH basal medium supplemented with 2.22 - 4.44 µM and BA, 2.69- 5.37 µM NAA.

In the Encapsulation - dehydration, Encapsulation - vitification and vitrification procedures, surviving shoots can be identified by greening of explants following 2 weeks of post culture. Regrowth can be defined as the shoots that regenerated to shoots in 6 weeks of postculture. Elongated shoots can be used for micropropagation and rooting and subculture was done every 4 weeks. For rooting well grown shoots can be transferred to solid MS medium used for multiplication.

### 3.7 Genetic stability of conserved materials

An important prerequisite for any conservation technique is that the regenerants produced from the conserved material should be true-to-type. There are ample evidences to indicate that under certain culture conditions the materials undergo genetic changes (somaclonal variations) and as a consequence lose their integrity and uniformity. This would be highly undesirable in spices varieties where the purpose is not only to conserve a genotype but also retain its specific quality traits. Thus testing for the genetic stability of *in vitro* conserved materials is of utmost importance. Besides morphology, cytology and isozyme profiling sophisticated biochemical and DNA-based techniques have enabled more critical analysis of the genetic stability of *in vitro* materials.

RAPD, ISSR and SSR analysis can be done to evaluate genetic fidelity of the cryopreserved lines of Spices. DNA isolation can be done as per CTAB method (Ausubel *et al.*, 1995 or Sambrook *et al.* 1989). RAPD and ISSR, SSR profiles were developed as per the method suggested by Williams *et al.*, (1990), Nirmal babu *et al.*, (2003, 2007) and Ravindran *et al.*, (2004).

Morphological characters coupled with RAPD profiles using 24 operon primers have indicated genetic fidelity among randomly selected micropropagated plants of Subhakara and Aimpriyan, indicating that micropropagation protocol can be used for commercial cloning of black pepper (Nirmal Babu *et al.*, 2003). Genetic uniformity of micropropagated *Piper longum* using RAPD profiling was reported by Ajith (1997) and Parani *et al.* (1997) for conservation.

Peter *et al* (2001) and Ravindran *et al* (2004) reported that the conserved materials of all the species conserved by them showed normal rate of multiplication when transferred to multiplication medium after storage. The normal sized plantlets when transferred to soil established with over 80% success. They developed into normal plants without any deformities and were morphologically similar to mother plants. RAPD profiling of these conserved plants also showed their genetic uniformity.

Ravindran *et al* (2004), Yamuna *et al* (2007) and Yamuna (2007) reported genetic uniformity was observed in cryo preserved and recovered plants of cardamom, ginger, black pepper and endangered species of Piper, *P. barberi* based on RAPD and ISSR profiling.

#### 4. Status of cryo conservation in spices

Reports on cryopreservation of spices are meager and limited. The present status of cryo preservation in major spices is given Table 2. The number of accessions conserved in cryo genebank at the National Bureau of Plant Genetic Resources (NBPGR), New Delhi are given in Table 3.

Application	Technique	Reference
<b>Black pepper (<i>Piper nigrum</i>) and related species</b>	Meristem culture	Philip <i>et al.</i> , 1992
Disease eradication propagation	Shoot Culture Leaf/root	Broome and Zimmerman, 1978
Cryopreservation	Seeds	Chaudhury and Chandel ,1994
Cryopreservation	synseeds	Ravindran <i>et al.</i> , 2004; Nirmal Babu <i>et al.</i> , 2007; Yamuna 2007
Cryopreservation	Seed	Decruse and Seeni, 2003
Slow growth storage and cryopreservation	Plantlets and shoot tips	Ravindran <i>et al.</i> , 2004; Nirmal Babu <i>et al.</i> , 2007; Yamuna 2007
<b><i>Allium</i> Spp</b>		
Disease eradication	Meristem culture and themotherapy	Conci and Nome, 1991
Cryopreservation	Shoot culture,	Keller 1991

Application	Technique	Reference
	microbullbets	
Cryopreservation	Shoot tips	Niwata 1995
<b>Cardamom (<i>Elettaria cardamomum</i> Maton)</b>		
Disease eradication	Meristem culture	Nadagauda <i>et al.</i> 1983
Cryopreservation	Seeds	Chaudhury and Chandel, 1995
Slow growth storage and cryopreservation	Plantlets and shoot tips	Ravindran <i>et al.</i> , 2004; Nirmal Babu <i>et al.</i> , 2007; Yamuna 2007
<b>Zingiber spp.</b>		
Disease eradication	Shoot cultures, shoot buds	Balachandran <i>et al.</i> ,1990
Propagation	Somatic embryo regeneration	Hosoki and Sagawa ,1977, Nirmal Babu, 1997
Cryopreservation	Synseeds	Sharma <i>et al.</i> , 1994
Slow growth storage and cryopreservation	Plantlets and shoot tips	Ravindran <i>et al.</i> , 2004; Nirmal Babu <i>et al.</i> , 2007; Yamuna <i>et al</i> 2007 ; Yamuna 2007
<b>Curcuma spp</b>		
Slow growth storage and cryopreservation	Plantlets and shoot tips	Ravindran <i>et al.</i> , 2004 ; Nirmal Babu <i>et al.</i> , 2007
<b>Vanilla spp.</b>		
Disease eradication	Apical meristem	Cereveta and Madrigal, 1981
Cryo preservation	Synthetic seeds	Ravindran <i>et al.</i> , 2004
Pollen Cryo preservation	Pollen	Minoo, 2002; Minoo <i>et al</i> 2011
Slow growth storage and cryopreservation	Plantlets and shoot tips	Ravindran <i>et al.</i> , 2004; Nirmal Babu <i>et al.</i> , 2007, Minoo and Babu 2009
<b>Herbal spices</b>		
Slow growth storage	<i>In vitro</i> plantlets	Nirmal Babu <i>et al.</i> 1996
<b>Capsicum</b>		
Cryopreservation	Seed	Peter <i>et al</i> 2002 ; Ravindran <i>et al</i> 2004
Cryopreservation	Pollen	Alexander <i>et al.</i> , 1991
Cryopreservation	Pollen	Rajasekharan and Ganeshan, 2003
<b>Fennel (<i>Foeniculum vulgare</i>)</b>		
Cold storage	Embryogenic	Umetsu <i>et al.</i> , 1995

Application	Technique	Reference
	suspension cells	
<b>Coriander</b> ( <i>Coriandrum sativum</i> )		
Cryopreservation	somatic embryos	Elena <i>et al.</i> , (2010)
<b>Mint</b> ( <i>Mentha spp.</i> )		
Cryopreservation	Somatic embryos	Leigh and Remi 2003
<b>Ocimum spp</b>		
Slow growth	Encapsulated beads	Mandal <i>et al</i> (2000)
<i>Syzygium francissi</i>		
	Shoot tips	Shatnawi <i>et al</i> (2004).
<i>Armoracia rusticana</i>		
Cryopreservation	Hairy root cultures	Phunchindawan <i>et al</i>
<b>Crocus spp.</b>		
	Encapsulated calluses	Chand <i>et al</i> (2000); Baghdadi <i>et al.</i> , (2010)

\*Ashmore, 1997, 2002 and Nirmal Babu *et al*, 1999, 2007, Yamuna 2007; Yamuna *et al* 2007

Table 2. Present status of information on cryo conservation of spices

Species	No.of accessions
Maintained as <i>in vitro</i> cultures	
Spices and industrial crops	380 accessions ( 7 genera, 27 species)
Medicinal and Aromatic plants	169 accessions ( 21 genera, 28 species)
Maintained in cryo bank	
Spices and Condiments	148 accessions
Medicinal and Aromatic plants	5 accessions
Total	702

Source: Annual Report NBPGR 2010-11

Table 3. Present status of Spices in *in vitro* and Cryo genebank at NBPGR

#### 4.1 Black pepper and related species

Cryopreservation of black pepper (*Piper nigrum* L.) seeds in liquid nitrogen (LN<sub>2</sub>) was reported by Choudhary and Chandel, (1994), and Choudhury and Malik (2004). Pepper seeds are recalcitrant and the seed viability decreases with reduction in moisture content. Seeds desiccated to 12% & 6% moisture contents were successfully cryopreserved in liquid nitrogen at -196°C, with a survival rate of 45% & 10.5% respectively (Chaudhury and Chandel 1994).

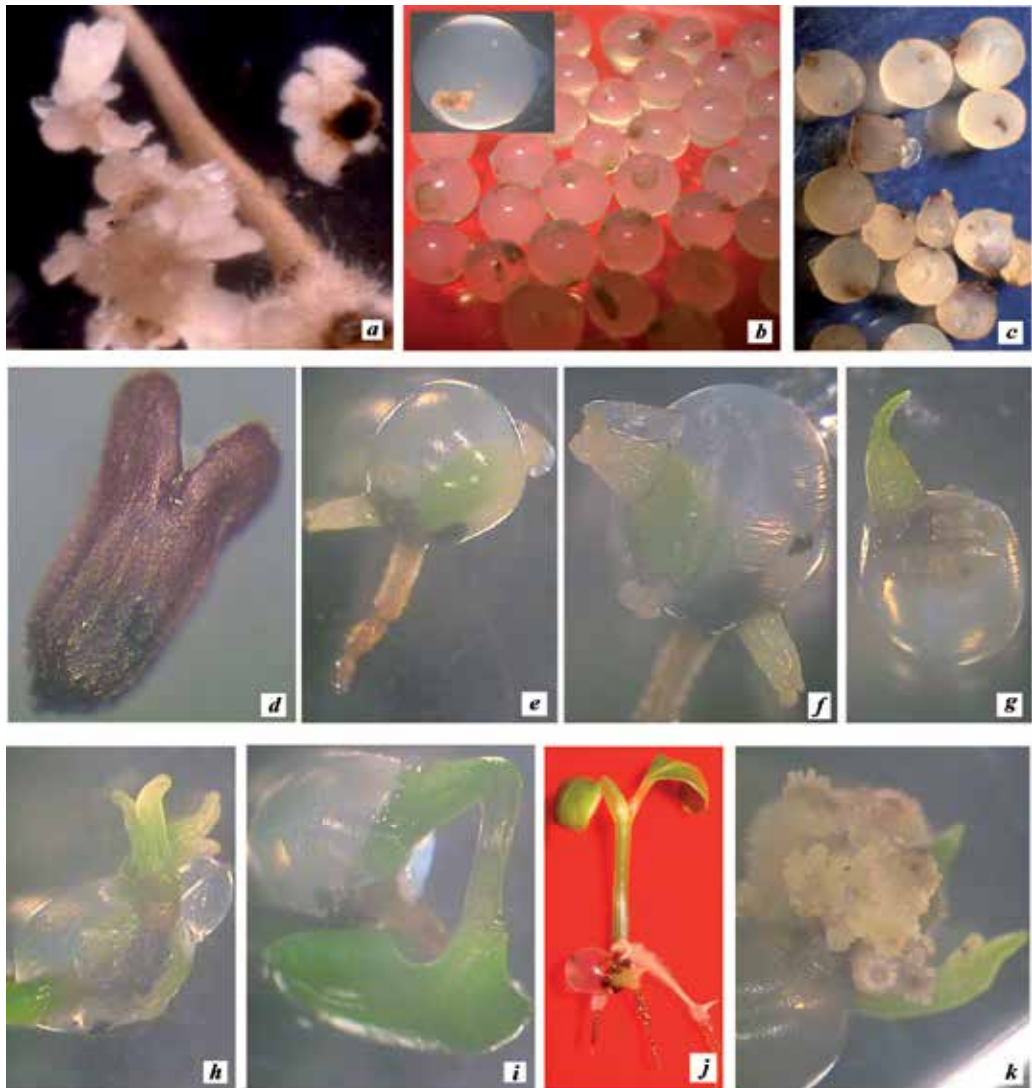

Fig. 1. Cryopreservation of black pepper somatic embryos by encapsulation dehydration. a) Somatic embryos used for cryopreservation, b) Somatic embryos encapsulated in Na-alginate, c) Encapsulated and dehydrated somatic embryos, d) Viable somatic embryo stained in red colour after cryopreservation, e), f), g), h) & i) Various stages of development of somatic embryos to plantlet after cryopreservation, j) Fully developed plantlet from a somatic embryo cryopreserved by encapsulation dehydration, k) A cluster of somatic embryos at different stages of development, originated from an embryogenic line after cryopreservation

Yamuna (2007) reported the effect of encapsulation-dehydration and vitrification methods on survival of cryo preserved somatic embryos in black pepper. In encapsulation dehydration treatment, the best survival rates (62 %) of somatic embryos was obtained after freezing, by preculturing in 0.7 M sucrose (direct) for 1 day, followed by dehydration in the

laminar air flow for 6 h which resulted in 21 % moisture content. In the vitrification procedure, the somatic embryos were precultured for 3 days on SH basal medium containing 0.3 M sucrose and subjected to vitrification treatment for 60 minutes at 25°C resulted in 71 % survival after cryopreservation. The study concluded that the embryogenic lines of *Piper nigrum* cultivar karimunda can be successfully cryopreserved following an encapsulation dehydration/desiccation procedure (62 % success). This success rate can be enhanced to 71 % using a vitrification/one step freezing in liquid nitrogen (Fig. 1). This was mainly because of the nature of somatic embryos which is more suitable to cryopreservation compared to shoot buds. The genetic stability of the conserved somatic embryos was proved by RAPD and ISSR profiling. Cryopreservation of encapsulated shoot buds of endangered *Piper barberi* was reported by Peter *et al* (2001) and Ravindran *et al* (2004).

Encapsulated shoot tips of *Piper barberi* were cryopreserved with 60% success using vitrification technique. In encapsulation vitrification the encapsulated shoot tips were precultured on MS medium, supplemented with 0.3 M, 0.5 M and 0.7 M sucrose (pH 5.8) for three days followed by dehydration with PVS2 solution (100%) at 0°C for 3 hours. After dehydration the beads (10 encapsulated shoot tips in 0.8 ml PVS2 solution per 1.5 ml cryotube) were frozen rapidly by direct immersion in to liquid nitrogen (-196 °C) and kept for one hour (Peter *et al* 2001 and Ravindran *et al* 2004). Yamuna 2007 also reported that studies on cryopreservation of endangered *P.barberi* shoot tips revealed that, the encapsulation- vitrification procedure produced higher survival (70 %) of cryopreserved shoot tips (Fig. 2) compared to encapsulation - dehydration which gave 40 % survival. Genetic fidelity studies showed that the regenerated plants were similar to the controls. Thus encapsulation - vitrification as a simple and efficient method for long term preservation of *P.barberi* propagules.

#### 4.2 Cardamom and related species

Choudhary and Chandel (1995) attempted cryo-conservation of cardamom (*Elettaria cardamomum* Maton.) seed. They tried to conserve seeds at ultra-low temperature by suspending seeds in cryovials in vapor phase of liquid nitrogen (-150°C) by slow freezing and also by direct immersion in liquid nitrogen (-196°C) by fast freezing. The result showed that seeds possessing 7.7-14.3% moisture content could be successfully cryo-preserved with 80% germination when tested after one-year storage in vapor phase of liquid nitrogen (-150°C).

Shoot tips(1.0-2.0mm) from *in vitro* grown plantlets of cardamom were subjected to progressive increase of sucrose concentrations (0.1, 0.3, 0.5, 0.7, 0.9, and 1.0) for two days each under the same cultural conditions as the parent plantlets. These shoot tips were transferred to 1.8ml cryotube containing ice cold PVS2 solution (30%(v/v) glycerol + 15% (v/v) ethylene glycol + 15% (v/v) DMSO in culture medium with 0.4 M sucrose, pH (5.8) ) at 0°C for 3 hours. After 3 hours equilibration at 0°C, the shoot tips were directly immersed into liquid nitrogen for 1 hour. Vials were thawed in 40°C water for 1 minute. The cryoprotectant was removed and the shoot tips were washed 2-3 times in 1.2M sucrose solution. About 70% Shoot tips were recovered on MS medium supplemented with BAP and NAA. But the encapsulation vitrification method gave only 60% success (Ravindran *et al* 2004).



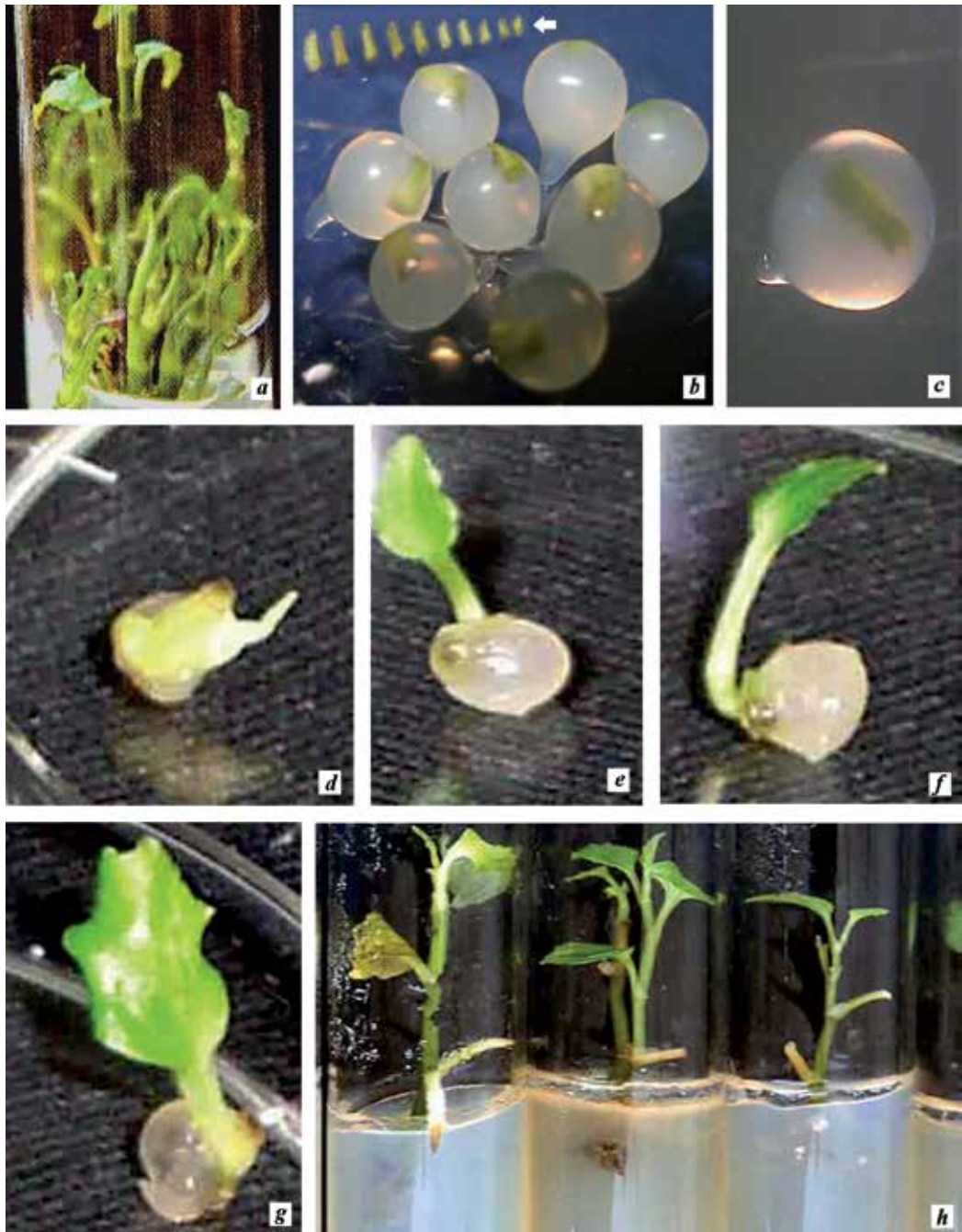

Fig. 2. Cryopreservation of *Piper barberi* by encapsulation vitrification. a) *In vitro* culture of *P. barberi*, b) & c) Shoot tips encapsulated in Na-alginate, arrow indicates shoot tip used as explants, d), e), f) & g) Various stages of development of cryopreserved shoot tips after post culturing, h) Regenerated plantlets after 3 months of post culturing

Yamuna (2007) tested the effect of encapsulation – dehydration, encapsulation vitrification and vitrification methods on cryopreservation of cardamom. In the vitrification treatment, to enhance tolerance to vitrification solution (PVS2), a two step sucrose preculture with 0.3 M and 0.75 M sucrose for one day each and an osmo protection step with a loading solution (LS) of 2 M glycerol and 0.4 M sucrose were performed prior to PVS2 treatment. The shoots

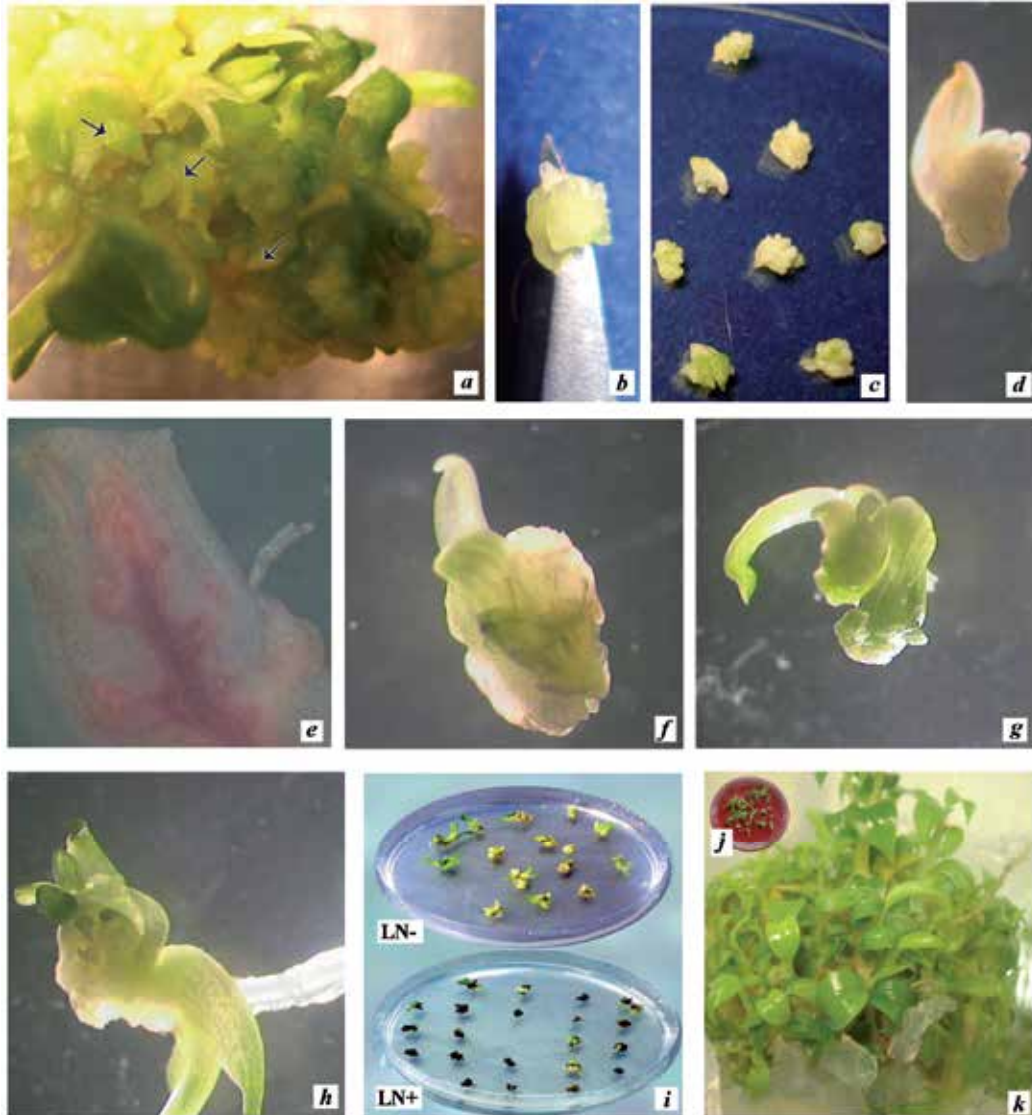

Fig. 3. Plant regeneration from cryopreserved miniature shoots of cardamom by vitrification. a) Cardamom culture with miniature shoots, b) & c) Excised meristematic clumps used for cryopreservation, d) Explant turned brown after cryopreservation, e) Viable tissues stained in TTC after cryopreservation, f), g), h), & i) Shoot development after 10, 14 and 25 days of post culturing, j) regenerating shoot buds in a petridish, k) Development of multiple shoots after 4 months of post culturing

dehydrated with PVS2 for 60 min retained a high level of shoot formation (70 %). The vitrification procedure resulted in higher regrowth (70 %) (Fig.3) when compared to encapsulation vitrification (62 %) and encapsulation dehydration (60 %). In all the three cryopreservation procedures tested, shoots grew after cryopreservation without intermediary callus formation. The genetic stability of cryopreserved cardamom shoots were confirmed using ISSR and RAPD profiling.

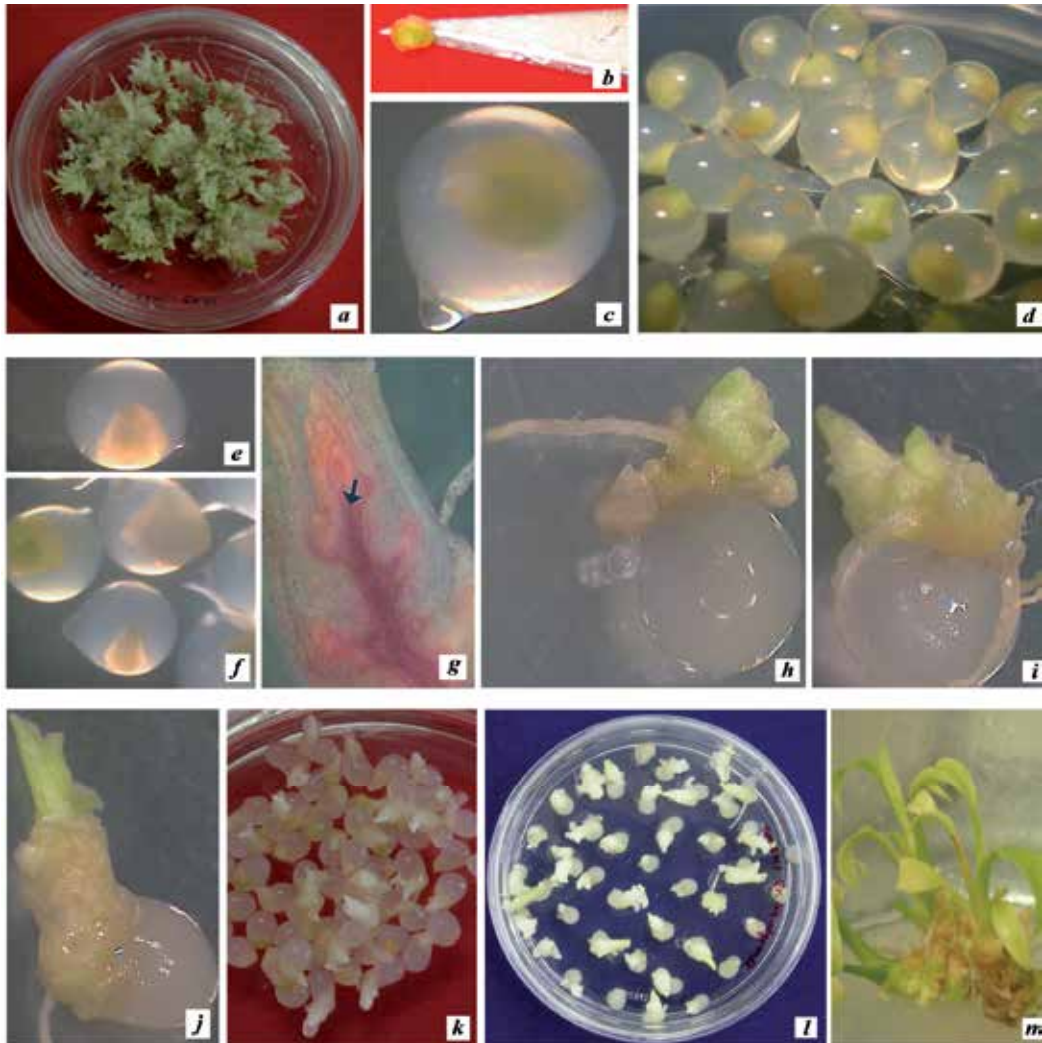

Fig. 4. Plant regeneration from cryopreserved shoot buds of ginger by encapsulation vitrification. a) *In vitro* culture, b) A typically excised shoot bud used for cryopreservation, c) & d) Shoot buds encapsulated in Na-alginate, e) & f) Shoot buds turned brown after thawing, g) Viable apical dome stained in red colour after liquid nitrogen storage (TTC staining), h) Regenerating shoot bud 20 days after post culturing, i) & j) Elongated shoot with no intermediary callus formation, k) & l) Regenerating shoot buds in petriplates, m) Plantlets regenerating from cryopreserved shoot bud

### 4.3 Ginger, turmeric and related species

Cryopreservation of Ginger (*Zingiber officinale* Rosc) and turmeric (*Curcuma longa* L.) shoot tips was successfully done with 80% of recovery using vitrification method. But the rate of recovery was only 40% when encapsulated shoot tips were dehydrated in progressive increase of sucrose concentration together with 4- 8 hrs. of desiccation (Peter *et al* 2001 and Ravindran *et al* 2004).

Efficient cryopreservation techniques were developed for *in vitro* grown shoots of ginger based on encapsulation dehydration, encapsulation vitrification and vitrification procedures (Yamuna *et al* 2007 and Yamuna 2007. The vitrification procedure resulted in higher re-growth (80 %) when compared to encapsulation vitrification (66 %) and encapsulation dehydration (41 %). The genetically stability of shoot apices was confirmed by molecular profiling. The RAPD and ISSR assays performed suggested that no genetic aberrations originated in ginger plants during culture and cryopreservation (Fig. 4).

### 4.4 Vanilla and related species

Technology for cryopreservation of vanilla germplasm - using encapsulation and vitrification methods - were available. Encapsulated *in vitro* grown shoot tips of vanilla could be cryo preserved with 70% success when pretreated with progressive increase of sucrose concentration (0.1M-1.0M) for one day each and dehydrated for 8 hrs (Peter *et al* 2001; Mino 2002 and Ravindran *et al* 2004) (Fig. 5).

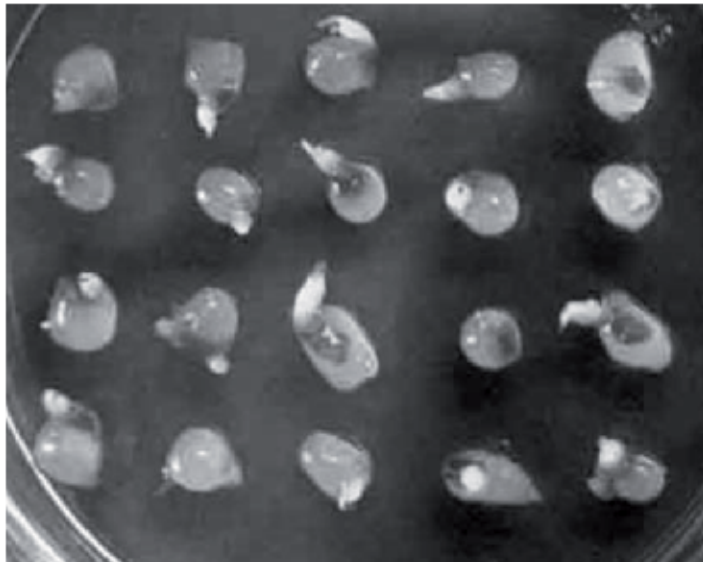

Fig. 5. Germination of cryopreserved encapsulated shoot tips protocorms of vanilla

Gonzalez-Arno, *et al.*, (2009) attempted to cryo-preserve *V. planifolia* Andr. using *in vitro* fragmented explants (IFEs) and the apices derived from them. Cryopreservation of apices from *in vitro* grown plants was achieved using the droplet vitrification protocol. Maximum survival (30%) and further regeneration (10%) of new shoots were obtained for apices derived from clusters of *in vitro* plantlets produced from microcuttings through a three-step droplet vitrification protocol: 1-d preculture of apices on solid MS medium with 0.3 M

sucrose; loading with a 0.4 M sucrose + 2 M glycerol solution for 20–30 min; and exposure to plant vitrification solution PVS3 for 30 min at room temperature.

Minoo (2002) reported cryopreservation of vanilla pollen for conservation (Fig. 6) of haploid genome as well as assisted pollination between species that flower at different seasons and successful fertilisation using cryopreserved pollen (Minoo, 2002, Minoo *et al* 2011). Pollen from two asynchronously flowering species of *Vanilla viz.*, cultivated *V. planifolia* and its wild relative *V. aphylla*, were cryopreserved after desiccation to 12 % moisture content, pretreated with cryoprotectant Dimethyl sulphoxide (5%) and cryopreserved -196°C in Liquid Nitrogen. This cryopreserved pollen was latter thawed and tested for their viability both *in vitro* and *in vivo*. A germination percentage of 82.1% and 75.4% in *V. planifolia* and *V. aphylla* pollen respectively were observed indicating their viability (Fig.6). This cryopreserved pollen of *V. planifolia* was used successfully to pollinate *V. aphylla* flowers resulting in fruit set (Fig.7). The seeds thus obtained were successfully cultured to develop hybrid plantlets. This system is of great importance and can be used for conserving the haploid gene pool of *Vanilla* in cryobanks and their subsequent utility in crop improvement (Fig. 6 and 7)

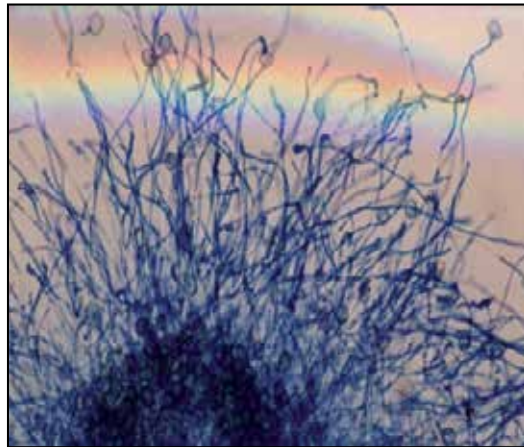

Fig. 6. Germination of cryopreserved Vanilla pollen



Fig. 7. Fruit set after pollination with cryopreserved pollen

#### 4.5 Capsicum

Plants could be successfully regenerated (Fig 8) from cryopreserved seeds of capsicum (Peter *et al* 2001 and Ravindran *et al* 2004). Alexander *et al* (1991) and Rajasekharan and Ganeshan. (2003) reported freeze preservation of capsicum pollen (*Capsicum annuum*) in liquid nitrogen ( $-196^{\circ}\text{C}$ ) for 42 months.



Fig. 8. Successful germination of cryopreserved seeds of capsicum

#### 4.6 Seed herbal and other spices

Elena *et al.*, (2010) successfully cryopreserved coriander (*Coriandrum sativum* L.) somatic embryos using sucrose pre-culture and air desiccation procedure utilized embryo clumps (ECs). The regrowth after cryopreservation and average number of new embryos developed from cryopreserved ECs were retained at the level of the untreated control (98% and 13 embryos per clump, respectively). Both normal and abnormal plants were produced from control and cryopreserved cultures, indicating that appearance of abnormalities was not related to cryopreservation. The regenerants with normal phenotype showed the same peaks of relative DNA content regardless of cryopreservation. The results suggest that simple desiccation method is effective for cryopreservation of coriander somatic embryos with subsequent regeneration. Plants could be regenerated from cryopreserved seeds of Anise. (Peter *et al* 2001).

Successful Cryopreservation of seeds, meristems, somatic or zygotic embryos were reported in *Allium* Spp (Niwata, 1995, Hyung *et al* 2003, Haeng *et al* 2003, 2004, 2005, Jung *et al* 2005, Gayle *et al* 2004). Preliminary success was reported in cryo preservation of Mint (Leigh and Remi 2003).

Most of the reports are confined to a few genotypes and hence the techniques standardized needs to be extended to more genotypes before adopting them for routine conservation. Reports of cryoconservation of spices like *Ocimum*, *Lavendula*, *Salvia* are available from National Bureau of Plant Genetic Resources (NBPGR), New Delhi.

Mandal *et al* (2000) reported propagation and conservation of four pharmaceutically important herbs, *Ocimum americanum* L. syn. *O. canum* Sims. (hoary basil); *O. basilicum* L. (swett basil); *O. gratissimum* L. (shrubby basil); and *O. sanctum* L. (sacred basil) using synthetic seed technology. Synthetic seeds were produced by encapsulating axillary vegetative buds harvested from garden-grown plants of these four *Ocimum* species in calcium alginate gel. The gel contained Murashige and Skoog (MS) nutrients and 1.1-4.4  $\mu$ M benzyladenine (BA). Shoots emerged from the encapsulated buds on all six planting media tested. However, the highest frequency shoot emergence and maximum number of shoots per bud were recorded on media containing BA. Of the six planting media tested, both shoot and root emergence from the encapsulated buds in a single step was recorded on growth regulator-free MS medium as well as on vermi-compost moistened with halfstrength MS medium. Rooted shoots were retrieved from the encapsulated buds of *O. americanum*, *O. basilicum*, and *O. sanctum* on these two media, whereas shoots of *O. gratissimum* failed to root. The encapsulated buds could be stored for 60 d at 4°C. Plants retrieved from the encapsulated buds were hardened off and established in soil.

An efficient procedure for the *in vitro* propagation and cryogenic conservation of *Syzygium francissi* was developed by Shatnawi *et al* (2004). Shoot tips excised from *in vitro*-grown plants were successfully cryostored at -196°C by the encapsulation-dehydration method. A preculture of formed beads on MS medium containing 0.75 M sucrose for 1 d, followed by 6 h dehydration (20% moisture content) led to the highest survival rate after cryostorage for 1h. This method is a promising technique for *in vitro* propagation and cryopreservation of shoot tips from *in vitro*-grown plantlets of *S. francissi* germplasm.

Hairy root cultures of *A Armoracia rusticana* Gaertn. Mey. et Scherb. (horseradish) were successfully cryopreserved by two cryogenic procedures (Phunchindawan *et al.*, 1997). Encapsulated shoot primordia were precultured on solidified Murashige-Skoog medium supplemented with 0.5M sucrose for 1 day and then dehydrated with a highly concentrated vitrification solution (PVS2) for 4 h at 0°C prior to a plunge into liquid nitrogen. The survival rate of encapsulated vitrified primordia amounted to 69%. In a revised encapsulation-dehydration technique, the encapsulated shoot primordia were precultured with a mixture of 0.5M sucrose and 1M or 1.5M glycerol for 1 day to induce dehydration tolerance and then subjected to air-drying prior to a plunge into liquid nitrogen. The survival rate of encapsulated dried primordia was more than 90%, and the revived primordia produced shoots within 2 weeks after plating. A long-term preservation of shoot primordia was also achieved by the technique. Thus, this revised encapsulation-dehydration technique appears promising as a routine method for the cryopreservation of shoot primordia of hairy roots

The effect of sucrose concentration and dehydration period on survival and regrowth of encapsulated calluses were also studied in 2 species of *Crocus* (Chand *et al* 2000). Highest survival (83.3; 88.9%) and regrowth (77.6; 83.3%) rates were obtained when encapsulated unfrozen calluses of *Crocus hyemalis* and *C. moabiticus* precultured with 0.1 M sucrose for two days without further air dehydration. After cryopreservation, the highest survival (55.6; 61.1%) and regrowth (16.7; 27.8%) rates were achieved when calluses of *C. hyemalis* and *C. moabiticus* were pretreated with 0.5 M sucrose for two days after two hours of dehydration. Viability of crocus decreased with increased sucrose concentration and dehydration period. Dehydration of encapsulated calluses of *C. hyemalis* and *C. moabiticus* with silica gel for one hour prior to freezing resulted in maximum rates of survival (77.8; 83.3%) and re-growth

(33.3; 72.1%). However, further studies should be initiated to improve regrowth of surviving embryogenic calluses and to study genetic stability after cryopreservation.

## 5. DNA bank

Concurrent with the advancements in gene cloning and transfer has been the development of technology for the removal and analysis of DNA. DNAs from the nucleus, mitochondrion and chloroplast are now routinely extracted and immobilized onto nitrocellulose sheets where the DNA can be probed with numerous cloned genes. In addition, the rapid development of polymerase chain reaction (PCR) now means that one can routinely amplify specific oligonucleotides or genes from the entire mixture of genomic DNA. These advances, coupled with the prospect of the loss of significant plant genetic resources throughout the world, have led to the establishment of DNA bank for the storage of genomic DNA.

The conserved DNA will have numerous uses viz, molecular phylogenetics and systematics of extinct taxa, production of previously characterized secondary compounds in transgenic cell cultures, production of transgenic plants using genes from gene families, *in vitro* expression and study of enzyme structure and function and genomic probes for research laboratories.

The vast resources of dried specimens in the world's herbaria may hold considerable DNA that would be suitable for PCR. It seems likely that the integrity of DNA would decrease with the age of specimens. Because there are many types of herbarium storage environments, preservation and collections, there is a need for systematic investigations of the effect of modes of preparation, collection and storage on the integrity of DNA in the world's major holdings.

The advantage of storing DNA is that it is efficient and simple and overcomes many physical limitations and constraints that characterize other forms of storage (Adams 1988, 1990, 1997, Adams and Adams 1991, Adams *et al* 1994). The disadvantage lies in problems with subsequent gene isolation, cloning and transfer but, most importantly, it does not allow the regeneration of live organisms (Maxted *et al.*, 1997). DNA banking is yet to catch up in spices. DNA samples of over 600 genotypes of spices is stored in the DNA bank of Indian Institute of Spices Research (IISR), Calicut.

## 6. Future focus

In contrast to the prevailing attitude among conservation biologists, globally there is considerable interest among cryobiologists in the use of *in vitro*, cold and ultra-cold technology for germplasm conservation. The procedures for plant material are given in-depth coverage by Reed *et al.* (2004) who stress equally the ecological and plant/germplasm health aspects preceding and following storage. Panis and Lambardi (2006) discussed the evolution of technologies for plant material, covering cell suspensions and callus cultures of herbaceous species, pollen, shoot meristems, woody species, as well as seed and embryonic axes. The *ex situ* gene bank at Gatersleben in Germany houses 986 potato accessions are cryopreserved and trials on other species are performed (Börner 2006). The National Bureau of Plant Genetic Resources (NBPGR), New Delhi has over 702 accession of various spices, medicinal and aromatic crops in its cryo gene bank (Table. 3). Keller *et al.* (2008) make the point that cryopreservation affords the best of conditions for the long-term maintenance of



plant material, particularly for vegetatively propagated species. Cryopreservation is the only viable method available for long-term preservation of the both plant and animal origin species. As an ultimate aim of cryoconservation is the reintroduction of preserved material into the field, it is appropriate at this point to consider the concept of restoration a little more closely. In terms of ultimate ecosystem restoration, the possibilities raised by *in vitro* conservation, including cryoconservation, do not mean that species selection should merely take random advantage of what germplasm has or can be conserved as there are many genetic, physiological and phenotypic considerations to be taken into account (Kramer and Havens 2009).

The establishment and maintenance of biological resource centers (BRCs) or germplasm conservatories requires careful attention to implementation of reliable preservation technologies and appropriate quality control to ensure that recovered cultures and other biological materials perform in the same way as the originally isolated culture or material. There are many types of BRC that vary both in the kinds of material they hold and in the purposes for which the materials are provided. All BRCs are expected to provide materials and information of an appropriate quality for their application and work to standards relevant to those applications. There are important industrial, biomedical, and conservation issues that can only be addressed through effective and efficient operation of BRCs in the long term. This requires a high degree of expertise in the maintenance and management of collections of biological materials at ultra-low temperatures, or as freeze dried material, to secure their long-term integrity and relevance for future research, development, and conservation. The application of cryogenic preservation in biotechnology and medicine has recently been a topic of interest. The use of cryogenic preservation in this area has given new horizon to this field of applications.

## 7. References

- Adams, R.P. and Adams, J.E., 1991. Conservation of Plant Genes: DNA Banking and *In Vitro* Biotechnology. Academic Press, New York.
- Adams, R.P., 1988. The preservation of genomic DNA: DNA Bank Net. *Amer. J. Bot.*, 75: 156.
- Adams, R.P., 1990. The preservation of Chihuahuan plant genomes through *in vitro* biotechnology:DNA Bank-Net, a genetic insurance policy. In: *Third Symposium on Resources of the Chihuahuan Desert Region*, (Eds.) Powell, A.M., Hollander, R.R., Barlow, J.C., McGillivray, W.B. and Schmidly, D.J. Printech Press, Lubbock, TX, pp. 1-9.
- Adams, R.P., 1997. Conservation of DNA: DNA banking. In: *Biotechnology and Plant Genetic Resources: Conservation and Use*, (Eds.) Callow, J.A. Ford-Loyd, B.V. and Newbury, H.J. Biotechnology in Agriculture Series, No. 19. CAB International, pp. 163-174.
- Adams, R.P., Miller, J.S., Golenberg, E.M. and Adams, J.E., 1994. *Conservation of Plant Genes 11: Utilization of Ancient and Modern DNA*. Missouri Botanical Garden Press. St. Louis, MI, 276 pp. 227.
- Ajith, A., 1997. Micropropagation and genetic fidelity studies in *Piper longum* L. In: *Biotechnology of Spices, Medicinal and Aromatic Plants*, (Eds.) Edison, S., Ramana,

- K.V., Sasikumar, B., Nirmal Babu K. and Santhosh J. Eapen. Indian Society for Spices, Calicut, India, p. 94-97.
- Alexander, M.P., Ganeshan, S. and Rajasekharan, P.E., 1991. Freeze preservation of capsicum pollen (*Capsicum annuum*) in liquid nitrogen (-196°C) for 42 months: Effect on viability and fertility. *PlantCell Incompatibility Newsletter*, 23: 1-4. NBPGR 2011 Annual Report, National Bureau of Plant Genetic Resources, 2010-11
- Ashmore, S.E., 1997. Status report on the development and application of *in vitro* techniques for conservation and use of plant genetic resources. International Plant Genetic Resources Institute, Rome, Italy. 67 p.
- Ausubel F M, Brent R, Kingston R E, Moore D D, Seidman, J G, Smith J A & Struhl K 1995 Short Protocols in Molecular Biology, John Wiley & Sons, New York, Ch. 2.4.
- Balachandran, S.M., Bhat, S.R. and Chandel, K.P.S., 1990. *In vitro* clonal multiplication of turmeric (*Curcuma longa*) and ginger (*Zingiber officinale* Rosc.). *Plant Cell Reports*, 3: 521-524.
- Bertaccini, A., Botti, S., Tabanelli, D., Dradi, G., Fogher, C., Previati, A., da Re, F., Nicola, S., Nowak, J. and Vavrina, C.S., 2004. Micropropagation and establishment of mite-borne virus-free garlic (*Allium sativum*), *Acta Horticulturae*, 631: 201-206.
- Börner A. Preservation of plant genetic resources in the biotechnology era. *Biotech J* 1: 1393-1404; 2006.
- Broome, O.C. and Zimmerman, R.N., 1978. *In-vitro* propagation of black pepper. *Hort. Sci.*, 43: 151-153.
- Chand, P.K., Mandal, J. and Pattnaik, S., 2000. Alginate encapsulation of axillary buds of *Ocimum americanum* L. (hoary basil), *O.basilicum* L. (sweet basil), *O. gratissimum* L. (shrubby basil), and *O. sanctum* L. (sacred basil). *In vitro Cellular and Developmental Biology (Plant)*, 36(4): 287-292.
- Chandrappa, H.M., Shadakshari, Y.G., Sudharshan, M.R. and Raju, B. ,1997. Preliminary yield trial of tissue cultured cardamom selections. In: *Biotechnology of Spices, Medicinal and Aromatic Plants*,(Eds.) Edison, S., Ramana, K.V., Sasikumar, B., Nirmal Babu K. and Santhosh J. Eapen. Indian Society for Spices, Calicut, India, p. 102-105.
- Chaudhury, R. and Chandel, K.P.S., 1994. Germination studies and cryopreservation of seeds of black pepper (*Piper nigrum* L.): A recalcitrant species. *Cryoletters*, 15: 145-150.
- Choudhary, R. and Chandel, K.P.S., 1995. Studies on germination and cryopreservation of cardamom (*Elletaria cardamomum* Maton.) seeds. *Seed Science and Biotechnology*, 23(1): 235-240.
- Choudhury, R. and Malik, S.K., 2004. Genetic conservation of plantation crops and spices using cryopreservation. *Ind. J. Biotechnology*, 3: 348-358.
- Conci, V.C. and Nome, S.F., 1991. Virus free garlic (*Allium sativum* L.) plants obtained by thermotherapy and meristem tip culture. *J. Phytopathol.*, 132: 186-192.
- Decruse, S W and Seeni, S 2003. Seed cryopreservation is a suitable storage procedure for a range of Piper species. *Seed Sci. Technol.* 31, 213-217.

- Du, Y.Q., Zhu, J.Z. and Shen, W.P., 2004. Study on virus elimination technology of garlic in Jiading by shoot tip culture. *Acta Agriculturae Shanghai*, 20(1): 9–12.
- Elena Popova, Haeng-Hoon Kim and Kee-Yoeup Paek 2010. Cryopreservation of coriander (*Coriandrum sativum* L.) somatic embryos using sucrose pre-culture and air desiccation *Scientia Horticulturae* 124 ( 4), 522-528.
- Engelmann F. Use of biotechnologies for conserving plant biodiversity. *Acta Hort* 812: 63–82; 2009.
- Engelmann, F., 1997. *In vitro* conservation methods. In: *Biotechnology and Plant Genetic Resources: Conservation and Use*, (Eds.) Callow, J.A., Ford-Loyd, B.V. and Newbury, H.J. Biotechnology in Agriculture Series, No. 19. CAB International, UK, pp. 119–161.
- Engelmann, F., 2000. Importance of cryopreservation for the conservation of plant genetic resources. In: *Cryopreservation of Tropical Plant Germplasm*, (Eds.) Engelmann, F. and Takagi, H. Current Research Progress and Application. Japan International Research Centre for Agricultural Sciences, Japan/International Plant Genetic Resources Institute, Rome, Italy, pp. 8–20.
- Engelmann, F., Benson, E.E., Chabrilange, N., Gonzalez-Arno, M.T., Mari, S., Michaux-Ferriere, N., Paulet, Glazmann, J.C. and Charrier, A., 1994. Cryopreservation of several tropical plant species using encapsulation/dehydration of apices. In. *Proc. VIIIth IAPTC Meeting*, Firenze, Italy.
- Engelmann, F., Dumet, D., Chabrilange, N., Abdelnour-Esquivel, A., Assy-Bah, B., Dereuddre, J. and Duval, Y., 1995. Cryopreservation of zygotic and somatic embryos from recalcitrant and intermediate-seed species. *Plant Genet. Resources Newsletter*, 103: 27–31.
- Frankel, O.H., 1975. Genetic resources survey as a basis for exploration. In: *Crop Genetic Resources for Today and Tomorrow*, (Eds.) O.H. Frankel and J.H. Hawkes. Cambridge University Press, Cambridge. pp. 99.
- Gayle, M., Volk, Nicholas Maness and Kate Rotindo, 2004. Cryopreservation of Garlic (*Allium sativum* L.) using Plant Vitrification Solution 2. *CryoLetters*, 25: 219–226.
- Gonzalez-Arno M.T, Claudia Esther Lazaro-Vallejo, Florent Engelmann, Roberto Gamez-Pastrana, Yolanda Maria Martinez-Ocampo, Miriam Cristina Pastelin-Solano and Carlos Diaz-Ramos 2009. Multiplication and cryopreservation of vanilla (*Vanilla planifolia* 'Andrews') *In Vitro Cellular & Developmental Biology - Plant* 45 (5): 574-582.
- Grout B W W 1995 Introduction to the *in vitro* preservation of plant cells, tissues and organs. In: Grout, B.W.W. (Ed.), *Genetic Preservation of Plant Cells in Vitro*. Springer-Verlag, Berlin. pp : 1–20.
- Haeng-Hoon Kim, Eun-Gi Cho, Hyung-Jin Baek, Chang-Yung Kim, ER Joachim Keller and Florent Engelmann, 2004. Cryopreservation of garlic shoot tips by vitrification: Effects of dehydration, Rewarming, unloading and regrowth conditions *CryoLetters*, 25: 59–70.
- Haeng-Hoon Kim, Jung-Bong Kim, Hyung-Jin Baek, Eun-Gi Cho, Young-Am Chaand Florent Engelmann, 2004. Evaluation of DMSO Concentration in Garlic Shoot tips during a Vitrification Procedure. *CryoLetters*, 25: 91–100.

- Haeng-Hoon Kim, Ju-Won Yoon, Jung-Bong Kim, Florent Engelmann and Eun-Gi Cho, 2005. Thermal analysis of Garlic Shoot tips during a Vitrification Procedure. *CryoLetters*, 26(1): 33–44.
- Himeno, H. and Sano, K., 1995. Synthesis of crocin, picrocrocin and safranal by saffron stigma like structures proliferated *in vitro*. *Agricultural Biology and Chemistry*, 51 (9): 2395–2400.
- Hoekstra, F.A., 1995. Collecting pollen for genetic resources conservation. In: *Collecting Plant Genetic Diversity: Technical Guidelines*, (Eds.) Guarino, L., Rao, V.R. and Reid, R. CAB International, Wallingford, UK, pp. 527–550.
- Hori, H., Enomoto, K. and Nakaya, H., 1988. Induction of callus from pistils of *Crocus sativus* L. and production of colour components in the callus. *Plant Tissue Culture Letters*, 5: 72–77.
- Hosoki, T. and Sagawa, Y., 1977. Clonal propagation of ginger (*Zingiber officinale* Rosc.) through tissue culture. *Horticulture Science*, 12: 451–452.
- Hyung-Jin Baek, Haeng-Hoon Kim, Eun-Gi Cho, Young-Am Chae and Florent Engelmann, 2003. Importance of explant size and origin and of preconditioning treatments for cryopreservation of garlic shoot apices by vitrification. *CryoLetters*, 24: 381–388.
- Ilahi, I. and Jabeen, M., 1992. Tissue culture studies for micropropagation and extraction of essential oils from *Zingiber officinale* Rosc. *Pakistan Journal of Botany*, 24(1): 54–59.
- IPGRI, 1996 Pragamme activities, germplasm maintenance and use. In: *Annual Report*, IPGRI. Rome. pp. 56–65.
- Iwananga, M., 1994. Role of International organisations in global genetic resource management. In: *Proc. 27th International Symposium on Tropical Agriculture Research*, Japan International Research Centre for Tropical Agricultural Sciences, Ministry of Agriculture, Forestry and Fisheries, Tsukuba, Japan, August, 25–26, 1993, p.1–6.
- Johnson, T.S., Ravishanker, G.A and Venkataraman, L.V., 1996. Biotransformation of ferulic acid vanillamine to capsaicin and vanillin in immobilised cell cultures of *Capsicum frutescens* *PlantCell, Tissue and Organ Culture*, 44(2): 117–123
- Jung-Bong Kim, Haeng-Hoon Kim, Hyung-Jin Baek, Eun-Gi Cho, Yong-Hwan Kim and Florent Engelmann, 2005. Changes in sucrose and glycerol content in garlic shoot tips during freezing using pvs3 solution. *CryoLetters*, 26(2): 103–112.
- Kartha K K & Engelmann F 1994 Cryopreservation and germplasm storage. In *Plant Cell and Tissue Culture*. Vasil, I. K. and Thorpe, T. A. (eds.), Kluwer Academic Publishers, Dordrecht/Boston/London. pp : 195–230.
- Kartha, K.K., 1985. In: *Cryopreservation of Plant Cells and Organs*, (Ed.) Kartha, K.K. CRC Press, Boca Raton, Florida, pp. 243–267.
- Keller E. R. J.; Kaczmarczyk A.; Senula A. 2008. Cryopreservation for plant genebanks—a matter between high expectations and cautious reservation. *CryoLetts* 29: 53–62.
- Keller, J., 1991. *In vitro* conservation of haploid and diploid germplasm in *Allium cepa* L. *Acta Hortic.*, 289: 231–232.

- Leigh, E. Towill and Remi Bonnart, 2003. Cracking in a vitrification solution during cooling or warming does not effect growth of cryopreserved mint shoot tips. *CryoLetters*, 24: 341-346.
- Lukose, R., Saji, K.V., Venugopal, M.N. and Korikanthimath, V.S., 1993. Comparative field performance of micropropagated plants of cardamom (*Elettaria cardamomum*). *Indian Journal of Agricultural Sciences*, 63(7): 417-418.
- Madhusoodanan, K.J., Kuruvilla, K.M., Vadiraj, B.A., Radhakrishnan, V.V. and Thomas, J., 2005. On farm evaluation of tissue culture vanilla plants vis-à-vis vegetative cuttings. *Proceedings of ICAR National Symposium on Biotechnological Interventions for Improvement of Horticultural Crops: Issues and Strategies*, Kerala Agricultural University, Trissur, Kerala, India, p. 89-90.
- Mandal, J., Pattnaik, S. and Chand, P.K. 2000. Alginate encapsulation of axillary buds of *Ocimum americanum* L. (hoary basil), *O. Basilicum* L. (sweet basil), *O. Gratissimum* L. (shrubby basil), and *O. Sanctum*. L. (sacred basil) *In Vitro Cellular & Developmental Biology - Plant* 36(4): 287-292.
- Maxted N, Brian, F and Hawkes, J G. 1997. Plant Genetic Conservation : the *in situ* approach. Springer. 446 pp
- Mc Cown, B.H. and Amos, R., 1979. Initial trials of commercial micropropagation with birch. *Proc.Inter. Plant Pro. Soc.*, 29: 387-393.
- Minoo Divakaran and Nirmal Babu, K. 2009. Micropropagation and In Vitro Conservation of Vanilla ( *Vanilla planifolia* Andrews ) pp 129-138. In SM Jain and PK Saxena (eds) Springer Protocols, Methods in Molecular Biology 547, *Protocols for In Vitro Cultures and Secondary Metabolite Analysis of Aromatic and Medicinal Plants*, The Humana Press, (Springer), USA.
- Minoo Divakaran, Nirmal Babu K. and Peter K. V. 2011. Cryopreservation of pollen and inter specific hybridization in important orchid species *V. planifolia* and *V. aphylla*. National Consultation for Production and Utilisation of Orchids 19-21 February, 2011 National Research Center for Orchids, Pakyong- 737106, Sikkim. Abstract. pp.98-99.
- Minoo Divakaran, Nirmal Babu K and Michel Grisoni 2010. Biotechnological applications In Vanilla, pp. 51-73 In Eric Odoux and Michel Grisoni (eds) *Vanilla*, CRC Press, Boca Raton, USA.
- Minoo, D., 2002. Seedling and somaclonal variation and their characterization in *Vanilla*. *Ph.D. Thesis*, Calicut University, Kerala, India.
- Murashige, T. and Skoog, F., 1962. A revised medium for rapid growth and bioassays with tobacco tissue cultures. *Physiol Plant*, 15: 473-493.
- Nadagauda, R S., Mascarenhas, A F & Madhusoodanan K J. 1983. Clonal multiplication of *Elettaria cardamomum* Maton. by tissue culture. *J. Plantn Crops* 11 : 60-64.
- Nag, K.K. and Street, H.E., 1975. Freeze preservation of cultured plant cells, 11. The freezing and thawing phases. *Physiol. Plantarum*, 340: 254-260
- Nair RR and Dutta Gupta 2003 Somatic embryogenesis and plant regeneration in black pepper (*Piper nigrum* L.): Direct somatic embryogenesis from tissues of germinating seeds and ontogeny of somatic embryos. *J. Hortic. Sci. Biotechnol*, 78 : 416-421

- Nirmal Babu, K., Geetha, S.P., Minoo D., Yamuna, G., Praveen, K., Ravindran, P.N. and Peter, K.V. 2007. Conservation of Spices Genetic Resources through *In Vitro* Conservation and Cryo- Preservation. pp. 210-233. In KV Peter and Z Abraham (ed). *Biodiversity in Horticultural Crops Vol 1*, Daya Publishing house, New Delhi
- Nirmal Babu, K., Geetha, S.P., Minoo, D., Ravindran, P.N. and Peter, K.V., 1999. *In vitro* conservation of germplasm. In: *Biotechnology and its Application in Horticulture*, (Ed.) S.P. Ghosh. Narosa Publishing House, New Delhi, pp. 106-129.
- Nirmal Babu, K., Minoo, D., Geetha, S.P., Ravindran, P.N. and Peter, K.V., 2005. Advances in Biotechnology of Spices and Herbs. *Ind. J. Bot.Res.*, 1(2): 155-214.
- Nirmal Babu, K., Ravindran, P.N. and Peter, K.V., 1997. *Protocols for Micropropagation of Spices and Aromatic Crops*. Indian Institute of Spices Research, Calicut, India, p. 35.
- Nirmal Babu, K., Ravindran, P.N. and Sasikumar, B., 2003. Field evaluation of tissue cultured plants of spices and assessment of their genetic stability using molecular markers. Final Report submitted to Department of Biotechnology, Government of India, pp. 94.
- Nirmal Babu, K., Rema, J., Sree Ranjini, D.P., Samsudeen, K. and Ravindran, P.N., 1996. Micropropagation of an endangered species of Piper, *P. barberi* Gamble and its conservation. *Journal of Plant Genetic Resources*, 9(1): 179-182.
- Niwata, E., 1995. Cryopreservation of apical meristems of garlic (*Allium sativum* L.) and high subsequent plant regeneration. *CryoLetters*, 16: 102-107.
- Panis B.; Lambardi M. Status of cryopreservation technologies in plants (crops and forest trees). In: Ruane J.; Sonnino A. (eds) 2006. The role of biotechnology in exploring and protecting agricultural genetic resources. FAO, Rome, pp 61-78;
- Parani, M., Anand, A. and Parida, A., 1997. Application of RAPD finger printing in selection of micropropagated plants of *Piper longum* for conservation. *Current Science*, 73(1): 81-83.
- Peter, K.V., Ravindran, P.N., Nirmal Babu, K., Sasikumar, B., Minoo, D., Geetha, S.P. and Rajalakshmi, K., 2002. *Establishing In vitro Conservatory of Spices Germplasm*. ICAR Project report. Indian Institute of Spices Research, Calicut, Kerala, India, pp. 131.
- Philip, V.J, Joseph, D., Triggs, G.S. and Dickinson, N.M., 1992. Micropropagation of black pepper (*Piper nigrum* L.) through shoot tip cultures. *Plant Cell Report*, 12: 41-44.
- Phunchindawan, M., Hirata, K., Sakai, A. and Miyamoto K. Cryopreservation of encapsulated shoot primordia induced in horseradish (*Armoracia rusticana*) hairy root cultures *Plant Cell Reports* 16(7): 469-473. DOI: 10.1007/BF01092768
- Quatrano, R.S., 1968. Freeze preservation of cultured flax cells using DMSO. *Plant*, 43: 2057-2061.
- Rajasekharan, P.E. and Ganeshan, S., 2003. Pollen cryopreservation in Capsicum species: A feasibility study. *Capsicum and Eggplant Newsletter*, 22: 87-90.
- Ravindran, P.N., Nirmal Babu, K., Saji, K.V., Geetha, S.P., Praveen, K. and Yamuna, G., 2004. Conservation of Spices genetic resources in *in vitro* gene banks. ICAR Project report. Indian Institute of Spices Research, Calicut, Kerala, India pp. 81.
- Ravishankar, G A., Sarma K S., Venkataraman L V. and Kalyan A K. 1988. Effect of nutritional stress on capsaicin production in immobilized cell cultures of *Capsicum annuum*. *Curr. Sci.* 57 : 381-383.

- Ravishankar, G.A., Sudhakar, J.T. and Venkataraman, L.V., 1993. Biotechnological approach of *in vitro* production of capsaicin. In: *Proceedings of the National Seminar on Post Harvest Technology of Spices*, Trivandrum, p. 75–82.
- Reed B. M.; Engelmann F.; Dulloo M. E.; Engels J. M. M. 2004. Technical guidelines for the management of field and *in vitro* germplasm collections. IPGRI Handbooks for Genebanks No. 7. IPGRI, Rome, Italy.
- Rekha Chaudhury and Malik, S.K., 2004. Genetic conservation of plantation crops and spices using cryopreservation. *Indian Journal of Biotechnology*, 3(3): 348–358.
- Sajina, A., Minoo, D., Geetha, S.P., Samsudeen, K., Rema, J., Nirmal Babu, K., Ravindran, P.N. and Peter, K.V., 1997. Production of synthetic seeds in a few spice crops. In: *Biotechnology of Spices, Medicinal and Aromatic Plants*, (Eds.) Edison, S., Ramana, K.V., Sasikumar, B., Nirmal Babu, K. and Santhosh, J.E. Indian Society for Spices, Calicut, India, p. 65–69.
- Sambrook J, Fritsch E F & Maniatis T 1989 *Molecular Cloning – a laboratory manual*. Vol.3. Cold Spring Harbor Laboratory Press, New York.
- Schenk R U & Hildebrandt A C 1972 Medium and techniques for induction and growth of monocotyledonous and dicotyledonous plant cell cultures. *Can. J. Botany*, 50:199-204.
- Sharma, T.R., Singh, B.M. and Chauhan, R.S., 1994. Production of encapsulated buds of *Zingiber officinale* Rosc. *Plant Cell Reports*, 13: 300–302.
- Shatnawi, M. A., Johnson K.A. and Torpy F.R. (2004) *In vitro* propagation and cryostorage of *Syzygium francissi* (Myrtaceae) by the encapsulation-dehydration method, *In Vitro Cellular & Developmental Biology - Plant* 40 (4): 403-407.
- Baghdadi, S.H, Shibli, R.A, Syouf M.Q., Shatnawi MA., Arabiat, A. and Makhadmeh I.M (2010) Cryopreservation by encapsulation-vitrification of embryogenic callus of wild crocus (*Crocus hyemalis* and *C. moabiticus*) Jordan J. Agricultural Sciences. 6 (3) 436-442.
- Umetsu, H., Wake, H., Saitoh, M., Yamaguchi, H. and Shimomura, K., 1995. Characteristics of cold preserved embryogenic suspension cells in fennel *Foeniculum vulgare* Miller. *Journal of Plant Physiology*, 146(3): 337–342.
- Venkataraman, L.V., Ravishanker, G.A., Sarma, K.S. and Rajasekaran, T., 1989. *In vitro* metabolite production from saffron and capsicum by plant tissue and cell cultures. In: *Tissue Culture and Biotechnology of Medicinal and Aromatic plants*, (Eds.) Kukreja *et al.* CIMAP, Lucknow, India, p. 147–151.
- Williams J G K, Kubelik A R, Livak K J, Rafalski J A & Tingey S V 1990 DNA polymorphisms amplified by arbitrary primers are useful as genetic markers. *Nucleic acid research* 18:6531-6535
- Withers, L.A., 1985. Cryopreservation of cultured cells and meristems. In: *Cell Culture and Somatic Cell Genetics of Plants*, Vol. 2: *Cell Growth, Nutrition, Cyto-differentiation and Cryopreservation*, (Ed.) I.K. Vasil. Academic Press, Orlando, Florida, pp. 253–316.
- Withers, L.A., 1987. Long-term preservation of plant cells, tissues and organs. *Oxford Surveys of Plant Mol. and Cell Biology*, 4: 221–272.

- Withers, L.A., 1991. Biotechnology and plant genetic resources Conservation. In: *Plant Genetic Resources Conservation and Management: Concepts and Approaches*, (Eds.) R.S. Paroda and R.K. Arora. IBPGR, New Delhi, pp. 273-297.
- Yamuna, G. 2007. *Studies on Cryopreservation of Spices Genetic Resources* Ph. D Thesis, University of Calicut, Kerala, India.
- Yamuna, G, Sumathi V., Geetha, S. P., Praveen, K., Swapna, N. and Nirmal Bab, K. 2007. Cryopreservation of *In Vitro* grown shoot of Ginger (*Zingiber officinale* Rosc). *CryoLetters*.28(4):241-252



# Cryopreserving Vegetatively Propagated Tropical Crops – The Case of *Dioscorea* Species and *Solenostemon rotundifolius*

Marian D. Quain<sup>1</sup>, Patricia Berjak<sup>2</sup>,

Elizabeth Acheampong<sup>3</sup> and Marceline Egnin<sup>4</sup>

<sup>1</sup>Council for Scientific and Industrial Research Crops Research Institute

<sup>2</sup>School of Biological and Conservation Sciences,

University of KwaZulu-Natal, Westville Campus, Durban

<sup>3</sup>Tissue Culture Laboratory, Department of Botany, University of Ghana, Legon, Accra

<sup>4</sup>Plant Biotechnology and Genomics Research Laboratory, Tuskegee University

<sup>1,3</sup>Ghana

<sup>2</sup>South Africa

<sup>4</sup>USA

## 1. Introduction

Root and tuber crops in the Sub-Saharan African region play a major role in daily diet, accounting for over 50% of the total staple. *Dioscorea* spp. and *Solenostemon rotundifolius* are among the tuber staples in West Africa. *Solenostemon rotundifolius* (Poir) J.K. Morton is an edible starchy tuber crop known to have originated in tropical Africa (Schippers, 2000). It occurs in western, central, eastern and southern Africa. In Ghana, it is popular in the northern part of the country and its common name is Frafra potato (Tetteh and Guo, 1993). In South Africa, it occurs mainly in coastal KwaZulu-Natal, eastern Mpumalanga and northwestern Cape and it is commonly known as Zulu round potato (Schippers, 2000). It is used to combat famine as it has high protein content, and has medicinal and social values (Kay, 1973). It flowers profusely, yet has rare seed production and is therefore propagated vegetatively by means of vine cuttings and tuber sprouts. Storage of the tuber in hot climates is a problem. In Ghana, it is stored in dry places or left on the ground under trees where conditions are cool. The tuber is stored buried in the ground to maintain the good quality for about two months. Otherwise the tuber sprouts within a shorter period. However, in South Africa, the tuber stores well through the winter months (Schippers 2000).

The germplasm is endangered because although field and *in vitro* gene banks are being used for conservation, these serve short to medium term purposes, and are expensive. Efforts to conserve the germplasm in the longer-term under slow growth *in vitro* are hampered by the relatively rapid growth of the cultures. Cryostorage which is recognised as the very safe cost effective option for the long-term conservation of genetic resources, especially vegetatively propagated species and crops with recalcitrant seeds (Engelmann & Engels., 2002) therefore

provide a viable alternative to the long-term storage, and ensure recovery of stable germplasm (Gonzalez-Arno *et al.*, 1999).

*Dioscorea* species, colloquially known as yams, of family Dioscoreaceae are perennial monocotyledonous climbers with underground tubers which, in some species are edible and serve as major staples in sub-Saharan Africa. Propagation is routinely vegetative, using either the tubers or vine cuttings. Farmers ensure the production of true-to-type crops by using clonal planting material, because of the social and staple importance attached to yams in sub-Saharan Africa. Hence the conservation of clonal germplasm of yam is extremely important. *Dioscorea* spp. has about 700 species within the family, nine of which are medicinal plants that accumulate steroid saponins in their rhizomes. Six species of *Dioscorea* *D. bulbifera*, *D. cayenensis*, *D. dumetorum*, *D. prahensis*, *D. alata* and *D. rotundata* contain mealy starch with a good level of vitamin C and other nutritive substances, which serve as major staples in sub-Saharan Africa. *Dioscorea rotundata* is native of West Africa, where it plays important role in the socio cultural life of the people. *Dioscorea alata* is the most widespread worldwide and is most cultivated in Southeast Asia, the Caribbean and West Africa. *Dioscorea rotundata* is now utilised in other parts of the world, and it has become a foreign exchange earner particularly in Ghana.

*In vitro* slow growth tissue culture methods have been used in conserving the germplasm (Ashun 1996; Ng & Daniel 2000; Ng & Ng 1991). Although this method usefully complements the traditional form of conservation, it serves only short- to medium-term storage purposes. Thus cryopreservation, which imposes a stasis on metabolic and deteriorative processes, is a worthwhile option to be explored.

Explant treatment to attain low water content which is critical for cryopreservation has in some protocols been by exposing tissues to stress, which enhance desiccation and cold tolerance (Withers 1985; Jitsuyama *et al.*, 2002). Such stress has been induced by abscisic acid, sugars, mannitol and sorbitol (Mastumoto *et al.*, 1998; Jitsuyama *et al.*, 2002; Veisseire *et al.*, 1993; Panis *et al.*, 2002; Walter *et al.*, 2002). The use of cryoprotectants, which exert osmotic stress and lead to loss of free water from tissues and vitrification when frozen has also been induced by using reagents such as sucrose, glycerol, DMSO, ethylene glycol, proline and many others (Engelmann *et al.*, 1994; Harding & Benson, 1994; Matinez-Montero *et al.*, 1998; Plessis *et al.*, 1993; Nishizawa *et al.*, 1993). Desiccation of tissues on activated silica gel (Hatanaka *et al.*, 1994; Cho *et al.*, 2002), in laminar air flow cabinets (Gonzalez-Benito & Pezez, 1994; Thammasiri, 1999) and flash driers (Berjak *et al.*, 1999; Pammenter *et al.*, 1991; Wesley-Smith *et al.*, 1992; Walter *et al.*, 2002; Potts & Lumkin 1997) have all been used to appreciably reduce water content to enhance cryotolerance. Although these treatments have all been reported to be successful in enhancing cryopreservation of some tissues, there are differences in response to known protocols which have been mainly attributed to specie and variety specificity (Gonzalez-Benito *et al.*, 2002; Martinez-Montero *et al.*, 1998; Panis *et al.*, 2002; Gonzalez-Arno *et al.*, 1999).

The prevention of the formation of lethal ice crystals when tissue is exposed to sub-zero temperatures is essential for successful cryopreservation, of vegetatively propagated germplasm. This chapter looks at the various attempts made to cryopreserve germplasm of *Solenostemon rotundifoliosus* and possible underlying mechanism that might have led to failure of tissues to respond to all methods utilized. Tissue survival, water contents and ultrastructure are used as parameters for analyzing response to various treatments. Also, response of yam *in vitro*-grown explants (shoot tips and axillary buds) to various desiccation

procedures and their ability to survive after exposure to cryogenic temperatures is investigated here, with the ultimate aim of developing a simple protocol for long-term conservation of the germplasm of *Dioscorea* species via cryopreservation. Parameters that need critical investigation are discussed.

## **2. Materials and methods**

### **2.1 *Solenostemon rotundifolius***

#### **2.1.1 Source of explant**

*In vitro* cultures of *Solenostemon rotundifolius* accession number UWR 002 was obtained from the *in vitro* gene bank that had been maintained under slow growth conditions at 18°C. *In vitro* cultures were multiplied on Murashige and Skoog (MS) medium (Murashige and Skoog, 1962) supplemented with 2% sucrose and 0.7% agar. Subculturing was carried out at four-weeks intervals. Cultures were maintained under a 16 h photoperiod (40  $\mu\text{M} / \text{m}^2 / \text{s}^1$ ) at 25°C  $\pm$ 1°C.

#### **2.1.2 Conditioning donor plant material in culture (pregrowth)**

Nodal cuttings were cultured on MS medium supplemented with either 0.058 M (2%) or 0.1 M sucrose or 0.1 M mannitol and 0.8% agar. Cultures were incubated for two to three weeks after which uniformly developed plantlets were used for various experiments.

#### **2.1.3 Conditioning excised explants in culture (preculture)**

*Solenostemon rotundifolius* nodal cuttings consisting two buds (having lateral buds which are microscopically globular and covered by leaf primordia as described by Niino *et al.*, 2000) were obtained from pregrown cultures, positioned on sterile nylon mesh cut side down and placed on fresh pregrowth media overnight. Explants were then transferred on mesh to media with higher sucrose concentrations (0.2, 0.3, 0.4, 0.5, 0.6, 0.7, 0.8, 0.9 and 1.0 M) sucrose for one to seven days. Media supplemented with 0.1 and 0.3 M mannitol were also used as pregrowth treatment. Incubation was under a 16 h photoperiod (40 $\mu\text{M}/\text{m}^2/\text{s}^{-1}$ ), at 25°C $\pm$ 1°C.

#### **2.1.4 Silica gel dehydration**

Explants were placed on oven-sterilised aluminium foil and dehydrated over approximately 35 g activated silica gel in covered 90 mm glass Petri dishes for 30 min to 16 h under sterile conditions.

#### **2.1.5 Rehydration**

Explants were rehydrated following cryoprotection treatment, silica gel dehydration and cooling. This was carried out in cryovials containing liquid MS medium supplemented with 0.1 M sucrose, 1mM  $\text{MgCl}_2 \cdot 6\text{H}_2\text{O}$  and 1  $\mu\text{M}$   $\text{CaCl}_2 \cdot 2\text{H}_2\text{O}$  for 30 minutes. Re-hydrated buds were cultured on growth medium, incubated under continuous dark conditions till signs of growth and development were observed (at least one week) before they were transferred to a dual photoperiod.

### 2.1.6 Cryoprotection

Liquid medium (MS) supplemented with 0.2, 0.4 M, 0.07 M, 0.14 M, sucrose, 2.0 M, 0.64 M, 1.28 M, 3.23 M glycerol, 2.42 M ethylene glycol, 0.017 M raffinose, 0.64 M, 1.28 M and 1.92 M DMSO, in varied combinations, plant vitrification solution II (PVS2), (Sakai *et al.*, 1990) and half strength PVS2 were used to cryoprotect nodal cutting explants for 5, to 40 minutes. Explants used were obtained from shoots grown on 0.1 M mannitol for 2-3 weeks. Excised explants were cultured on 0.3 M mannitol for 72 hours, and cryoprotected in cryovials, using 1 ml cryoprotectant solution (the 1 ml cryoprotectant was decanted and replaced with 0.5 ml during cryoprotection). To enhance explant cryoprotection, dehydration over activated silica gel for 60 minutes either before or after cryoprotection was also investigated. Following cryoprotection, the cryoprotectant solution was decanted and explants were washed three times with rehydration solution (described above). However, explants subjected to cooling, (LN or freezing to -70°C) were immediately on retrieval, rewarmed in water bath at 40°C for two - three minutes. Following rewarming, tissues were then allowed to stay for 30 min in the rehydration solution before blotting dry, and cultured on growth medium. Incubation was in continuous dark conditions till signs of growth and development were observed. Developing cultures were transferred to 16 h photoperiod.

### 2.1.7 Frafra potato assessments

#### 2.1.7.1 Water content determination

Individually weighed explants were oven-dried at 80°C for 48 hours to determine dry mass. Water content was determined individually for 5-10 explants, and expressed on a dry mass (g H<sub>2</sub>O g<sup>-1</sup> dry mass) basis.

#### 2.1.7.2 Survival

Explant survival was assessed weekly for three weeks after culturing. Generally, 8-10 explants were used per treatment and experiments were replicated three times. Surviving explants were those which showed shoots with buds, leaves, and root development.

#### 2.1.7.3 Transmission electron microscopy

A standard glutaraldehyde-osmium fixation method was used, followed by dehydration through an acetone series embedding in a low viscosity epoxy resin (Spurr, 1969). Sections of the meristematic regions of axillary buds and shoot tips were collected on 200 mesh hexagonal copper 3.05 mm grids. Sections were post-stained with uranyl acetate and lead citrate, washed with distilled water, and viewed and photographed with a JEOL 100-S transmission electron microscope.

## 2.2 *Dioscorea rotundata*

### 2.2.1 Source of explant

*In vitro* cultures of *Dioscorea rotundata* ("Pona"), accession number PS 98 013 were obtained from the *in vitro* gene bank of the Department of Botany, University of Ghana, Legon, where the plants were maintained under long-term slow growth conditions at 18°C. Cultures were multiplied and sub-cultured at six-week intervals on Murashige and Skoog (MS) medium

(Murashige and Skoog 1962) with 2.5  $\mu\text{M}$  kinetin, 20 mg l<sup>-1</sup> L-cysteine, 2% (0.056 M) sucrose, 0.7% agar, and maintained under a 16 h photoperiod (40  $\mu\text{mol m}^{-2}\text{ s}^{-1}$ ) at 25 $\pm$ 1°C.

### 2.2.2 Conditioning excised explants in culture (preculture)

Yam shoot tips (~1 - 2 mm) were excised from cultures grown on MS pregrowth medium [as above, except containing 3% (0.09 M) sucrose instead of 2% sucrose] for five weeks, placed on sterilised nylon mesh, which was then positioned, explant cut side down, on fresh medium, overnight. Explants were then transferred on the mesh to semi-solid medium with higher sucrose concentrations (0.3, 0.5, 0.7 and 1.0 M, the control material continuing to be exposed to 0.09 M sucrose) in 90 mm Petri dishes for one, three, five or seven days, each followed by transfer either to growth-enhancing medium (MS complete salts with vitamins, 3% sucrose, 5  $\mu\text{M}$  kinetin, 20 mg l<sup>-1</sup> L-cysteine, 0.8% agar, 1% filter-sterilised casein hydrolysate at pH 5.7  $\pm$  0.1), or further conditioned for cryopreservation.

### 2.2.3 Silica gel dehydration and cooling of explants

Yam explants dehydrated using the same methodology as described above for Frafra potato. Dehydrated explants were placed in cryovials, which were plunged into, and maintained in, liquid nitrogen for one hour, or cooled at 1°C min<sup>-1</sup> in a Nalgene cryo freezing container (Mr Frosty™), to -70°C, and maintained for at least four hours at this temperature. Rewarming was effected immediately on retrieval from the cryogen, in a water bath at 40°C for two to three minutes for all treatments.

### 2.2.4 Rehydration

The rehydration solutions consisted of MS complete salts with vitamins, 2.5  $\mu\text{M}$  kinetin, 20 mg l<sup>-1</sup> L-cysteine, 1mM MgCl<sub>2</sub>.6H<sub>2</sub>O, 1 $\mu\text{M}$  CaCl<sub>2</sub>.2H<sub>2</sub>O, 1% casein hydrolysate (filter-sterilised), and 1 M sucrose, at pH 5.7 $\pm$ 0.1, magnesium and calcium chlorides having been shown to enhance explant recovery of date palm somatic and pea zygotic embryos (MyCock 1999). Rehydration was for 30 minutes. Rehydrated buds were blotted dry and cultured on growth medium (as above). Cultures were incubated under continuous dark conditions at 24 $\pm$ 1°C until signs of growth and development were observed, before they were transferred to 16 h photoperiod (40  $\mu\text{mol m}^{-2}\text{ s}^{-1}$ ) at 25 $\pm$ 1°C.

### 2.2.5 Cryoprotection with modified plant vitrification solution 2(MPVS2)

Explants that had been pregrown and precultured were exposed to 1 ml plant vitrification solution 2 (PVS2) as designed by Sakai and colleagues (Sakai et al., 1990), but modified as follows (MPVS2): basic MS medium, 30% glycerol, 15% ethylene glycol, 15% DMSO (v/v), 0.4 M sucrose (w/v), 0.1 M CaCl<sub>2</sub>.2H<sub>2</sub>O and 1% D-raffinose at pH 5.7 $\pm$ 0.1. Inclusion of calcium chloride and raffinose has been found to be beneficial in promoting recovery after cryopreservation in other species (Mycock, 1999). Explants were treated for 0, 10, 20, 30 or 40 minutes in cryovials. The vitrification solution was decanted and the explants washed three times in 1 ml rehydration solution (as described above) for 30 minutes, then cultured on growth medium and incubated in the dark. Cultures were transferred to the alternating light/dark conditions once signs of growth and development were observed. Prior to being cooled to -70 or -196°C, cryoprotected explants were suspended in fresh 0.5 ml MPVS2 in

cryovials. The explants to be cryopreserved were then exposed to cryogenic conditions for specified durations, rewarmed, vitrification solution removed, rehydrated, and incubated as described above.

## **2.2.6 Yam assessment**

### **2.2.6.1 Water content determination**

Water content of yam explants was determined following the same procedure as described for Frafra potato above.

### **2.2.6.2 Survival assessment**

Yam explant survival was determined following the same procedure as described above of Frafra potato.

### **2.2.6.3 Tetrazolium test for viability**

Shoot tips which were pretreated with high sucrose concentrations; pretreated and cryoprotected with MPVS2; pretreated, cryoprotected, and vitrified, were cultured on growth medium for 5-7 d following which they were transferred to a 0.1% aqueous solution of 2,3,5-triphenyl tetrazolium chloride (TTZ) and incubated in the dark overnight. Control material was obtained from cultures under standard growth room conditions. Patchy red staining, located around the meristematic region as a result of respiratory activity in viable cells was scored as the tissue having survived the various treatments.

## **3. Results and discussion**

### **3.1 Frafra potato**

#### **3.1.1 Pregrowth**

Water contents of Frafra potato nodal cutting explants following pregrowth on medium supplemented with 0.058 M (2%) sucrose was extremely high ( $22.25 \pm 1.7$  gH<sub>2</sub>O g<sup>-1</sup> dry wt) to enhance successful cryopreservation. As explant size and geometry have a marked effect on the success of freezing hydrated material (Wesley-Smith *et al.*, 1995), nodal cuttings (two buds per explant) to be used for cryopreservation experiments were split into two halves with one bud per explant, this adequately lowered water content of explants ( $8.78 \pm 1.07$  gH<sub>2</sub>O/g dry wt). The water content of the single (well trimmed) bud is similar to that of explants excised from greenhouse established plant ( $10.16 \pm 0.98$  g/g dry wt. data shown in Table 2). Since cultures grown on medium supplemented with 2% sucrose were extremely wet for cryopreservation, higher sucrose or mannitol concentration (0.1 M) was employed to enhance desiccation tolerance, which subsequently improves cryotolerance .

Pregrowth of explants on medium supplemented with 0.1 M mannitol lowered the water content of explants from 19.5 under control condition (medium supplemented with 0.058 M sucrose), to 10.4 gg<sup>-1</sup>, which did not affect survival (Fig. 1). The ultrastructure was as well constituted as that of the control explants (Plate 1a), with ongoing metabolism indicated by abundant cristate mitochondria (Plate 1b), Golgi bodies and profiles of endoplasmic reticulum (insert). Growth on 0.1 M sucrose supplemented medium, also lowered the water

content of explants ( $11.4 \text{ g g}^{-1}$ ) as shown in Fig. 1, this observation is in agreement with response of oil palm explant water content when treated with sucrose (Dumet *et al.*, 1993) and while this did not reduce survival it resulted in severely distended organelles and evidence of tonoplast disruption and lobed nuclei (Plate 1d and e). Sucrose has been extensively used to treat plant tissues prior to cryopreservation (Panis *et al.*, 2002; Grospietsch *et al.*, 1999; Gonzalez-Benito & Perez, 1994; Santos & Stushnoff 2003), studies have however, not investigated the structural effect of sucrose on tissue. The damage revealed by ultrastructure (Plate 1f) could have predisposed explants negatively to subsequent steps.

### 3.1.2 Preculture

Culturing individual Frafra potato buds on 0.3 M sucrose for 3 d (Table 1), lowered water content from  $11.4 \text{ g g}^{-1}$  (after growth on 0.1 M sucrose medium) to  $7.3 \text{ g g}^{-1}$  and explant survival was at 100 %. This level of sucrose has been applied in other crops such as carrots (Dereuddre *et al.*, 1991), wasabi (Mastumoto *et al.*, 1998), and African violet (Shibili *et al.*, 2004). Similarly, explant on medium supplemented with 0.3 M mannitol which were derived from 0.1 M mannitol supplemented medium, water contents reduced further from 10.47 to  $7.42 \text{ g g}^{-1}$  and survival was still at 100 % (Table 1). Mannitol and its isomer, sorbitol have been used for pre-treatment of plant tissues before cryopreservation (Wang *et al.*, 2001) as well as in long term storage culture media as osmoticums (Ashun, 1996; Egnin *et al.*, 1998). The growth of explants on regrowth medium following preculture varying sucrose media is shown in the Plate 2.

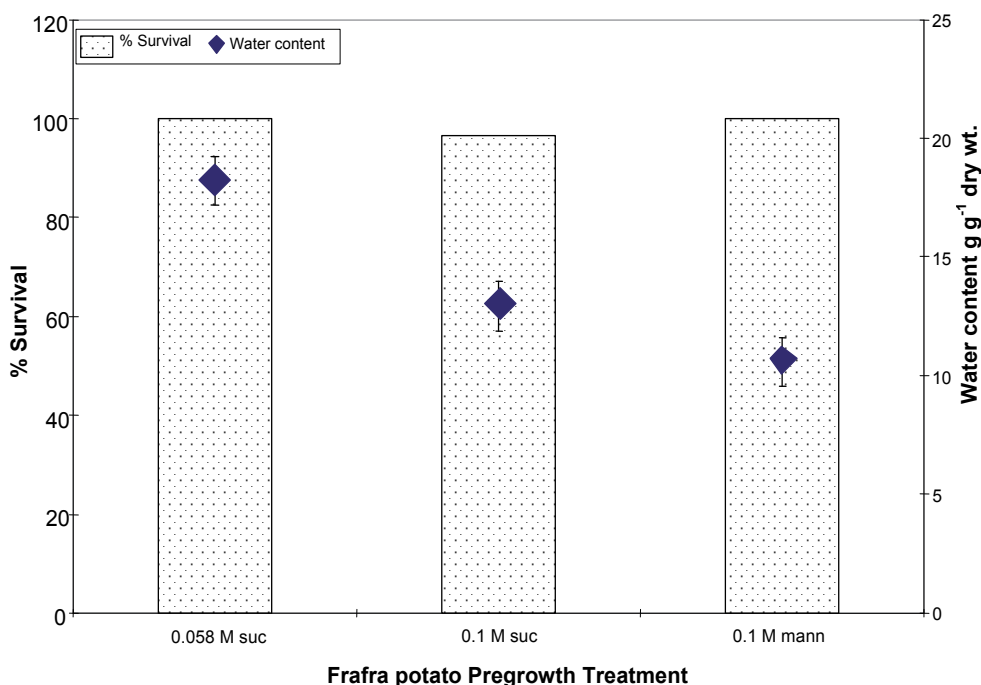

Fig. 1. Survival and water content of Frafra potato cultures on three pregrowth media  $\pm$  SD. Survival  $P \geq 0.05$ ,  $n=30$ , and WC  $P \leq 0.05$ ,  $n=15-30$

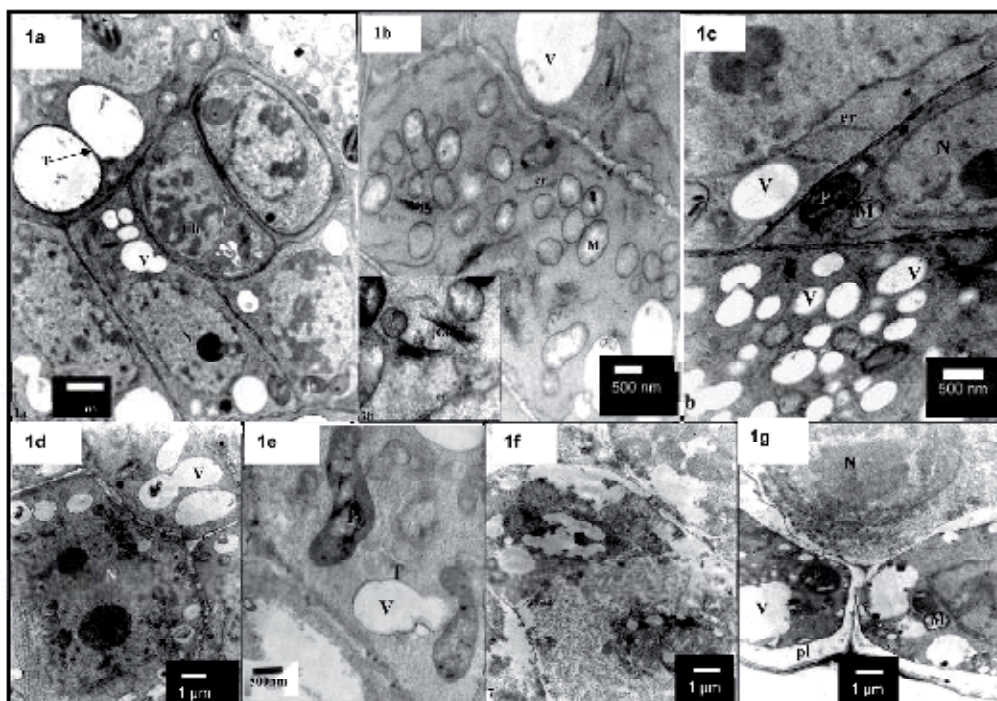

Plate 1. Ultrastructure of *Solenotemon rotundifolius* explant meristematic cells. Legend are as follows: Ch, heterochromatin, V, vacuoles, T, tonoplast, P, plastids, M, mitochondrial, ER, endoplasmic reticulum, N, nucleus Gb, Golgi bodies, pl, plasma membrane.

Plate 1a Control explants cultured on 2% sucrose supplemented medium. Cells show oval nuclei, normally-distributed heterochromatin, vacuoles each with a well-defined tonoplast, small, relatively dense plastids, circular mitochondrial profiles with dense matrices, and profiles of endoplasmic reticulum.

Plates 1b (insert), & c. Explants pregrown on 0.1 M mannitol for three weeks cells (1b). Ongoing metabolic activity indicated by abundance of mitochondria, Golgi bodies and profiles of endoplasmic reticulum (insert), many plasmodesmata are visible. A group of relatively small vacuoles is shown (1c), which appeared typical of mannitol treatment to reduce water content.

Plate 1d After sucrose (0.1 M) pregrowth for three weeks, there was evidence of tonoplast disruption, lobed nuclei with possibility of vacuole fission or fusion. Plate 1(e) shows somewhat distorted plastids and a potentially autolysing cell (lower left) where vacuolar dissolution (tonoplast disruption) appears to have occurred. Such events would have predisposed these explants negatively to subsequent steps.

Plate 1f. Explants pregrown on 0.1 M sucrose, precultured on 0.3 M sucrose for 3 d and then dehydrated over activated silica gel for 120 min. Water content was 0.16 g g<sup>-1</sup> while survival of the sample was only 2.5%. Most specimens presented this appearance of advanced intracellular deterioration, nuclear remains; and plasma membrane.

Plate 1g. Explants pregrown on 0.1 M mannitol and then preculture on 0.3 M mannitol for 3 d, dehydrated over activated silica gel for 120 min, during which water content was lowered to 0.11 g g<sup>-1</sup>. This was accompanied by 38.1% survival. Nuclear and cytoplasmic derangement had occurred although some cells had few intact organelles, shown in this illustration of what was probably a non-surviving explant.



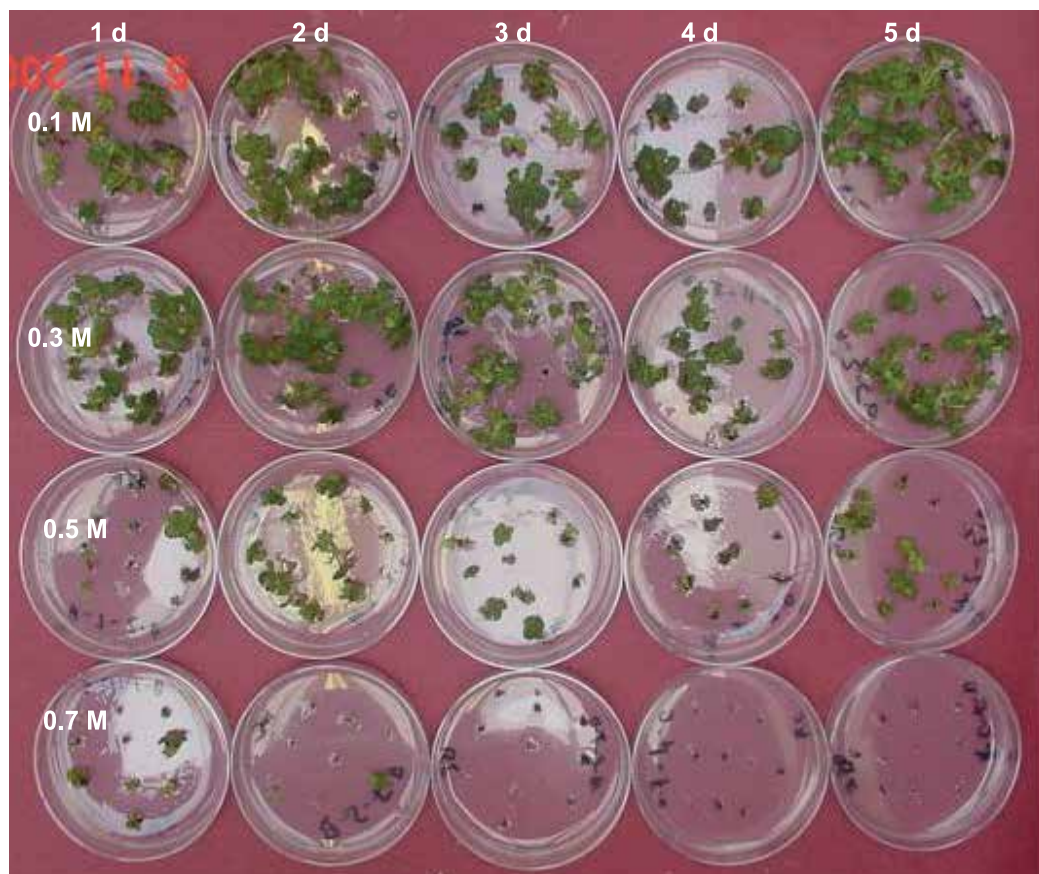

Plate 2. Development of *Solenostemon rotundifolius* explants pregrown and precultured on medium supplemented with increasing sucrose concentrations 0.1 M, 0.3, 0.5 M, and 0.7 M for 1 d, 2 d, 3 d, 4 d, and 5 d and grown on growth medium in 90mm Petri plates. Data taken at 3-weeks.

### 3.1.3 Dehydration

Dehydrating explants over silica gel, considerably lowered water content (Table 1). In experiments by other investigators, this technique has been successfully used to dehydrate and cryopreserve citrus axes, (Santos & Stushnoff, 2003) and encapsulated somatic embryos of *Coffea canephora* (Hatanaka *et al.*, 1994).

Mannitol treated (0.3 M) explants of Frafra potato used in this particular experiment, when dehydrated over activated silica gel, the lowest water content ( $0.11 \text{ g g}^{-1}$ ) was recorded for 120 min dehydration and survival was 73% (Table 1). However, sucrose treated (0.3 M) explants indicated lowest water content of  $0.16 \text{ g g}^{-1}$  which although, is higher than in mannitol (stated above), survival was as low as 5% (Table 1). It is possible that damage suffered by tissues as revealed by ultrastructure (Plate 1d&e) during sucrose treatment predisposed them to further damage on dehydration. It was evident here that mannitol treated tissue are more desiccation tolerant than sucrose treated tissues although other

Treatment	Water Content g/g dry weight	% Survival
0.058 M sucrose for 1 d	18.22 ± 0.96	100 ± 0
0.058 M sucrose for 3 d	22.37 ± 2.02	86.67 ± 4.7
0.058 M sucrose for 5 d	16.7 ± 0.65	100 ± 0
0.1 M sucrose for 1 d	12.93 ± 0.66	96.67 ± 0.86
0.1 M sucrose for 3 d	14.18 ± 0.03	100
0.1 M sucrose for 5 d	12.74 ± 0.4	100
0.3 M sucrose for 1 d	8.82 ± 0.4	100
0.3 M sucrose for 3 d	7.98 ± 0.73	96.67 ± 0.86
0.3 M sucrose for 5 d	6.17 ± 0.39	100
0.5 M sucrose for 1 d	4.13 ± 0.38	96.67 ± 0.86
0.5 M sucrose for 3 d	4.22 ± 0.41	86.67 ± 2.27
0.5 M sucrose for 5 d	3.37 ± 0.27	96.67 ± 0.86
0.1 M sucrose dehydrated for 0 min	11.45 ± 0.50	100
0.1 M sucrose dehydrated for 60 min	0.58 ± 0.15	50 ± 1.8
0.1 M sucrose dehydrated for 90 min	0.56 ± 0.12	30 ± 3.6
0.1 M sucrose dehydrated for 120 min	0.14 ± 0.02	35 ± 10.6
0.3 M sucrose dehydrated for 0 min	6.09 ± 0.16	96.67 ± 0.8
0.3 M sucrose dehydrated for 60 min	0.79 ± 0.17	56.25 ± 1.14
0.3 M sucrose dehydrated for 90 min	0.37 ± 0.07	33.18 ± 0.58
0.3 M sucrose dehydrated for 120 min	0.16 ± 0.61	5 ± 2.4
0.1 M mannitol for 3 d and dehydrated for 0 min	10.51 ± 0.6	80 ± 2.08
0.1 M mannitol for 3 d and dehydrated for 60 min	0.42 ± 0.07	40 ± 0.11
0.1 M mannitol for 3 d and dehydrated for 90 min	0.29 ± 0.05	40 ± 0.11
0.1 M mannitol for 3 d and dehydrated for 120 min	0.08 ± 0.01	20 ± 0.09
0.3 M mannitol for 3 d and dehydrated for 0 min	7.42 ± 0.38	96.67 ±
0.3 M mannitol for 3 d and dehydrated for 60 min	0.31 ± 0.05	71 ± 0.09
0.3 M mannitol for 3 d and dehydrated for 90 min	0.24 ± 0.05	70 ± 0.10
0.3 M mannitol for 3 d and dehydrated for 120 min	0.11 ± 0.4	73 ± 0.10

Table 1. Treating FP 002 with different sucrose concentrations during development of Preculture conditions using nodal cuttings with single buds

reports have successfully used sucrose to induce dehydration tolerance (Dumet *et al.*, 1993; Grospietsch *et al.*, 1999; Santos & Stushnoff, 2003).

Sucrose treated tissues had totally been deranged after 120 minutes (Plate 1f) of dehydration compared with mannitol tissues (Plate 1g) which has some intact nuclei and few organelles present. These must be responsible for the survival recorded (Table 1). It is possible the presence of the intact nuclei and organelles in the mannitol treated cells could be reconstituted for normal plant growth and development to occur.

Crop accession	Water content
FP UER 001	18 + 5.14
FP UER 002	10 + 0.9
FP UWR 003	9.6 + 2.7
FP UER 004	14.6 + 2.1
99/053	8.4 + 1.1
99/1033	11.2 + 0.6
99/016	11.2 + 1.6
99/022	11.35 + 0.6

Table 2. Water content of screenhouse of Frafra potato established in greenhouse for three months

### 3.1.4 Cryoprotection

Explants treated with 0.1 and then 0.3 M sucrose or mannitol, on exposure to PVS2 indicated only about 20% survival (Table 3). This observation was contrary to report by Niino *et al.*, (2000) that *S. rotundifolius* innala recorded high survival on treating with PVS2 and subsequently, 85% survival on exposure to liquid nitrogen. *Solenostemon rotundifolius* used in this study, were extremely sensitive to both the loading solution (0.4 M sucrose + 0.2 M glycerol, data not shown) and PVS2, which in other reported studies, led to successful cryopreservation of other crops including *S. rotundifolius* (Wang *et al.*, 2003; 2001; Turner *et al.*, 2001; Niino *et al.*, 2000). On screening for appropriate vitrification (cryoprotection) solution, the following cryoprotection solutions listed in Table 3 were tested. It was indicative from results that DMSO and Ethylene Glycol at the concentration (15%) that they occur in PVS2 did not have any lethal effect on the explants. However, sucrose and Glycerol at the concentrations that they occur in PVS2 (0.4 M and 30% respectively) were found to be lethal to the tissues (Table 3). The use of PVS2 at half concentration and a combination of 2.5% Glycerol, 5% sucrose, 7.5% DMSO and 7.5% Ethylene glycol (coded PVSB) resulted in survival and growth of explants. The responses confirm indication that cryoprotectants at full-strength are toxic to plant cells (Rheinhoud *et al.*, 1995). These treated explants, however did not survive on exposure to liquid nitrogen. Combining the cryoprotection treatment with dehydration (data not shown) as has been reported by other investigators as enhancing high cryosurvival (Wang *et al.*, 2003; 2001; Turner *et al.*, 2001), did not result in survival after cryopreservation in this study. Encapsulating explants prior to treatment with PVS2 also did not result in explant survival.

Ultrastructural studies indicated that tissues treated with ½PVS2 (Plate 3) and PVSB (Plate 4) for 15 min, which survived had well constituted cells, however, some tonoplasts were not

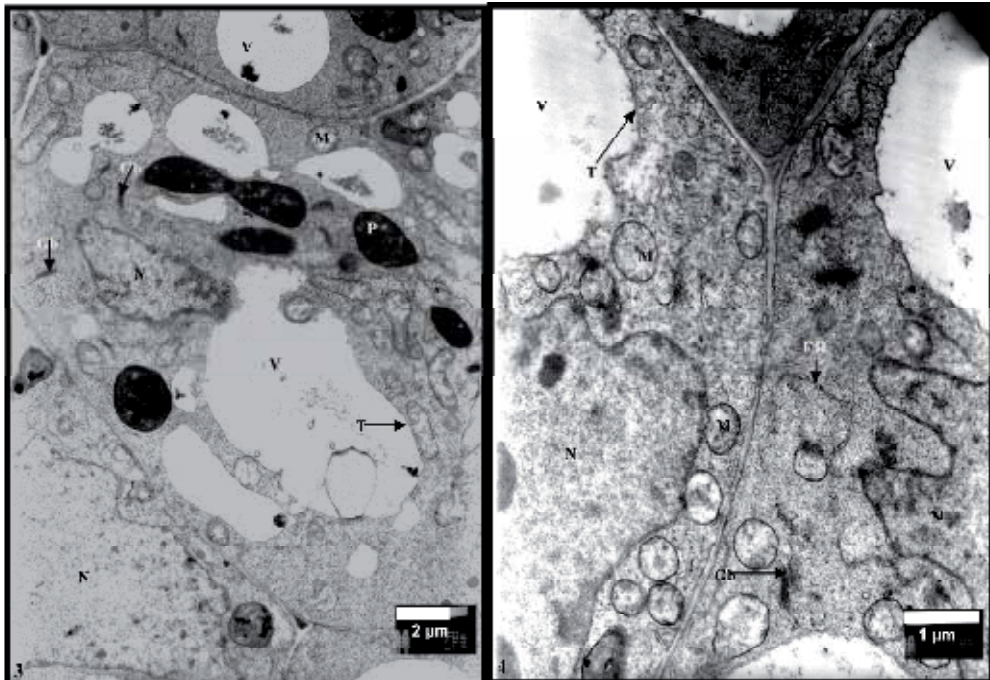

Plate 3 & 4. Ultrastructure of surviving Frafra potato after mannitol pregrowth and preculture treatments, followed by subjecting explants for 15 min to  $\frac{1}{2}$ PVS2 (Plate 3) and PVSb (Plate 4). (3) Although cells were well organised, some extent of autophagy was concluded to have occurred, in terms of intravacuolar inclusions in the  $\frac{1}{2}$  PVS2-treated material. (4) Cells appeared exceptionally active but showed distinctly lobed nuclei (N). Other organelles that can be recognized are mitochondria (M), endoplasmic reticulum (ER), Golgi bodies (Gb), plastids (P), and vacuoles (V) with tonoplast (T) intact.

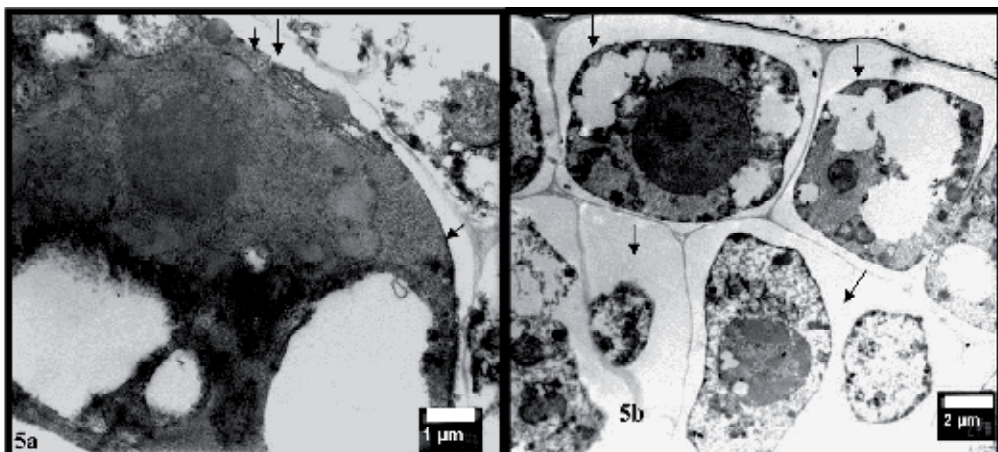

Plate 5a & b. Ultrastructure of non-surviving Frafra potato following mannitol pregrowth and preculture treatments, then subjecting explants to  $\frac{1}{2}$ PVS2 for 15 (Plate 5a) and 40 min (Plate 5b) Cells were highly plasmolysed (arrows) and damaged to the extent that organelles could not be easily recognized.

distinct and some extent of autophagy was observed in ½ PVS2, treated tissues (Plate 3). Slight deposition of starch was observed in plastids of tissues treated with PVSB. Tissues, which did not survive after the 15min treatments (Plate 5a&b), showed highly plasmolysed cells and totally deranged cells, exposing the lethal effect of vitrification solution.

Increasing glycerol and sucrose concentration as well as long exposure duration led to reduced survival and regeneration of encapsulated nodal cuttings treated with the plant vitrification solutions as indicated in (Table 4). This observation is contrary to other crops where encapsulation vitrification has been highly recommended for successful cryopreservation (Charoensub *et al.*, 1999; Wang *et al.*, 2003) however confirms that cryoprotectants can be damaging to plant tissues and the extent of effect varies according to type and concentration of cryoprotectant as well as plant species (Berjak *et al.*, 1996).

Treatment	% Survival
3.23 M Glycerol + 0.4 M Sucrose + 0.017 Raffinose	33.64 ± 1.39
3.23 M Glycerol + 0.4 M Sucrose	22.71 ± 2.77
PVS2 + 0.017 M raffinose	8.28 ± 0.20
PVS2	20 ± 0
0.07 M S + 0.3 M G 15 min	100
0.07 M S + 0.3 M G+0.14 M S +0.6 M G, 15 min	100
0.14 M S + 0.6 M G, 15 min	100
0.64 M DMSO for 15 min	90±0
1.28 M DMSO for 15 min	100± 0
1.92 M DMSO for 15 min	100 ± 0
2.42 M EG + 0.017 M Raffinose	84.24±1.46
2.42 M EG	77.28±0.97
½ PVS2 + 1% Raffinose	80.63±1.82
0.3 M G + 0.2 M S + 0.96 M DMSO + 2.42 M EG + 0.017 M Raffinose (PSVB)	69.17±2.26

S: sucrose, G: Glycerol, EG: Ethylene Glycol

Table 3. Survival (± SD) of Frafra potato explants, pregrown (0.1 M mannitol) and precultured (0.3 M mannitol) prior to cryoprotection treatments. n=30 – 40, P<0.05

Frafra potato Variety	Treatment	Water Content g/g dry wt	% Survival
FP 002	PVSB for 15 min	4.13 ± 0.16	55 ± 2.04
	PVSB for 40 min	4.45 ± 0.25	55 ± 2.04
	½ PVS2 for 15 min	3.36 ± 0.06	38.75 ± 0.3
	½ PVS2 for 40 min	3.26 ± 0.17	0
	PVS2 for 15 min	2.00 ± 0.10	20
FP 003	PVSB for 15 min	2.66 ± 0.16	59.01 ± 1.5
	½ PVS2 for 15 min	2.58 ± 0.23	53.76 ± 2.3
	Control	5.63 ± 0.31	100
FP 004	PVSB for 15 min	2.91 ± 0.28	54.56 ± 1.4
	½ PVS2 for 15 min	2.7 ± 0.14	66.62 ± 3.47
	Control	6.59 ± 0.62	100

½PVS2 and PVSB were always supplemented with 0.017 M Raffinose

Table 4. FP explants treated with Plant Vitrification Solution

### 3.1.5 Cryopreservation

Although explants treated with mannitol and dehydrated over activated silica gel for 90 minutes had water content  $0.24 \text{ gg}^{-1}$  and survival was 70 % (Table 1), when exposed to liquid nitrogen, survival was nil. Ultrastructure indicated extensively degraded cells with withdrawn and broken plasmalemma, cytoplasm and nucleoplasm were all damaged (Plate not shown). Explants from all dehydration treatments did not survive on exposure to liquid nitrogen as well as ultra-cold liquid nitrogen (slash), although, it has been reported that rapid cooling enhance cryosurvival (Wesley-Smith *et al.*, 1992). Having dehydrated explant to water content of  $0.11 \text{ gg}^{-1}$ , it is obvious from ultrastructure (not shown) that the prolonged stress exerted decreased explant ability to withstand freezing since there is a level below which dehydration stress is increasingly apparent (Wesley-Smith *et al.*, 1992). Unlike the loss of viability in *S. rotundifolius*, explant at higher water contents have been reported to survive on exposure to liquid nitrogen (Berjak *et al.*, 1995; Kioko *et al.*, 1998 and 2000)

During cryopreservation all metabolic processes cease, it is possible that mannitol treated explants were too active metabolically judging from the high number of mitochondria occurring in the cytoplasm (Plate 1b). Hence bringing the systems to a halt caused a breakdown in all the plant metabolic systems causing cytoplasm to lose its viability since following dehydration, only few organelles could be observed in cytoplasm (Plate 1f). It is also possible that with the occurrence of high number of small vacuoles in mannitol treated explant (Plate 1c) which is a characteristic whereby, large vacuoles volumes are reduced by redistributing them into smaller vesicles on exposure to mannitol (Gnanapragasam & Vasil, 1992), being an advantage for survival since water contents are relatively low (Reinhoud *et al.*, 1995). However, it is probably that, the water present in the vacuoles did not have high viscosity, which would prevent the formation of ice crystals during cooling and thawing hence causing degeneration of plant cell integrity.

Sucrose treated explant, ultrastructure indicated cytoplasmic breakdown at all stages of treatment. Although the plant cell were not in a high metabolic state prior to exposure to liquid nitrogen, cellular degeneration had already set in and may have had a major role to play, leading to loss of viability on exposure to liquid nitrogen.

The above and all associated factors need to be investigated further. These will help optimise plant cell structure prior to cryopreservation. Based on the ultrastructural studies carried out, it is obvious that the use of mannitol for pregrowth and preculture treatment, the plant tissues develop capability to tolerate other stress (desiccation). *S. rotundifolius* tissues besides yielding high explant survival, results in stable ultrastructure for further plant growth and development. However the treatment does not necessarily result in survival on exposure to cryopreservation. The use of higher concentration of mannitol may enhance cryotolerance. Other critical factors that have to be investigated include maturation of explant supported by constitution of ultrastructure and related water content which play crucial rôle in cryopreservation (Chandal *et al.*, 1994; Berjak *et al.*, 1993). However, the extremely high water content ( $18.7 - 9.64 \text{ g/g dry wt}$ ) of plant even in the greenhouse (graph not shown), may still make it difficult to cryopreserved tissues of local accessions of *S. rotundifolius*. Several attempts were made to adequately harden Frafra potato (Table 5) prior to subjecting explants to various treatments and then cooling however, none of them resulted in explants survival after cooling.

Treatment	Water content
Six months in culture	8.1± 1.2
Shoot grown from tuber under sterile conditions (8 weeks)	19.5 ± 1.6
Vitrified shoot grown from tuber under sterile conditions (8 weeks)	24.7 ± 3.9
Normal shoots transferred to vented vessels (3 weeks)	8.2 ± 1.3
Vitrified shoots transferred to vented vessels (3 weeks)	12.7 ± 2.5
Normal shoots transferred to dry air-line (3 weeks)	7.2 ± 1.0
Normal shoots transferred to humid air-line (3 weeks)	18.4 ± 2.2
Cultures transferred to RITA vessels	13.0 ± 2.2

Table 5. Other attempts to acclimatize the new Frafra potato accession 99/053 to lower water content that might enhance cryosurvival.

### 3.2 *Dioscorea rotundata*

Comparatively, yam explants cultured on medium supplemented with 0.3 M sucrose for 3-5 d considerably reduced tissue water content from about 12.2 g g<sup>-1</sup> dry mass to between 4.8 and 5.5 g g<sup>-1</sup> dry mass before cryoprotection with modified PVS2 (MPVS2) or silica gel dehydration. Following cryoprotection with MPVS2 the Plate (6) below indicated the growth of nodal explants.

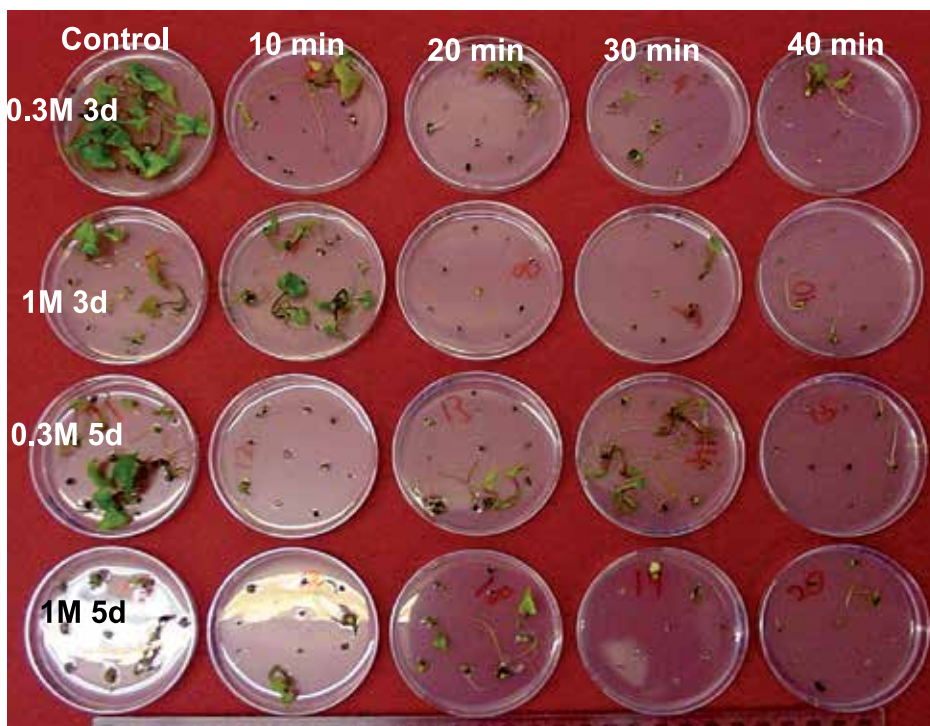

Plate. 6. Growing cultures of yam explant subjected to pregrowth on 0.09 sucrose supplemented medium for 5 weeks, precultured on medium containing 0.3 m sucrose for 3 or 5 d, treated with MPVS2 for varied duration and unloaded with rehydration solution containing 0.3 or 1 M sucrose and cultured on regeneration medium for six week

Ultrastructural studies indicated that cells had deposits of starch in plastids following sucrose treatments. Survival for *D. rotundata* shoot tips treated with MPVS2 vitrification solution, and cooled to  $-70^{\circ}\text{C}$ , was 16% for 15 min treatment and 44% for 40 min. Explant rehydration was in 1.0M sucrose supplemented solution. After the 40 min MPVS2 treatment the TTZ test indicated 88% viability retention of explants cooled to  $-70^{\circ}\text{C}$ , and 44% at  $-196^{\circ}\text{C}$ . Plantlet development was obtained for  $-70^{\circ}\text{C}$ -cooled shoot tips, whereas only callus development occurred from tissues exposed to liquid nitrogen. Explant regeneration was not obtained with silica gel dehydration techniques. It was concluded that vitrification-solution based cryopreservation presently offers the best option for conservation of this *Dioscorea* species.

#### 4. Conclusions

Undoubtedly, cryopreservation has high potential for the long-term storage of vegetative explants. It is, however, vital to achieve appropriate tissue water content and the quality of the initial material. This study has shown that vitrification-based cryopreservation protocol is useful for yam explants. However, Frafra potato is extremely sensitive to the vitrification based protocol while explants of the latter easily become hyperhydric and are impossible to dehydrate sufficiently for cryopreservation.

The findings are relevant for cryopreservation of a range of yam germplasm (Quain et al., 2009) and also provide a sound basis for further attempts to cryopreserve Frafra potato genetic resources. The technique represents developed simple, cost-effective and potentially reliable methodology that does not require sophisticated equipment. Such procedures should be adapted for germplasm conservation of other species, using limited resources in laboratories in sub-Saharan Africa.

Findings in this present study suggest that in order to achieve an optimal recovery of cryopreserved explants, the donor plants should be adequately conditioned and the recovery media enriched while testing the different cryogenic procedures. Although encapsulation vitrification and encapsulation dehydration procedures have been used in cryopreservation procedure, for the yams used in this study, the use of non-encapsulated explant proved to be a better option. The encapsulation of explants after cryopreservation in the production of e.g. synthetic seeds (Naidoo, 2006; Perán *et al.*, 2006), is, however, worth exploring.

The key to successful cryoprotection has been suggested as inducing tolerance to vitrification solutions and the ability of explants to tolerate dehydration treatment by cryoprotectants has been hypothesised by several researchers as the determining factor for successful cryosurvival (Langis & Steponkus, 1990; Reinhoud *et al.*, 1995). It is still not conclusive whether having been hardened, explants being used in procedures would survive cryopreservation. However, Frafra potato explants were not amenable to conditioning by any of these pretreatments. The requirements for successful cryopreservation differ for different species. There is the possibility that the optimum developmental stage of the explant for successful cryopreservation varies from species to species. Therefore there is the need to ascertain and test many parameters on the basis of each species. However, culture conditions especially those that will obviate hyperhydricity, are of paramount importance, as presently indicated for Frafra potato.



It can be concluded from the experiments that:

- Successful cryopreservation of *Dioscorea rotundata* is possible using a simple vitrification protocol.
- The procedure incorporates
  - pregrowth of the donor plant on 0.09 M sucrose-supplemented medium for five weeks,
  - preculture on 0.3 M sucrose supplemented medium for 5 d
  - MPVS2 solution for 40 min,
  - Rapid cooling in liquid nitrogen or slow cooling to -70°C.
- For the first time successful cryopreservation of *Dioscorea rotundata* accession 'Pona' which is an elite variety in Ghana has been achieved.
- The technique represents developed simple, cost-effective and potentially reliable methodology that does not require sophisticated equipment.
- Procedures can be adapted for germplasm conservation of other species, using limited resources in laboratories in sub-Saharan Africa.
- To achieve an optimal recovery of cryopreserved explants the donor plants should be adequately conditioned.
- Frafra potato is extremely sensitive to the vitrification based protocol.

Frafra potato explants easily becomes hyperhydric, and are impossible to dehydrate sufficiently for cryopreservation, this provide a sound basis for further attempts to cryopreserve Frafra potato genetic resources. These observations therefore make available information for further investigation towards development of cryopreservation protocol.

## 5. Acknowledgements

The authors wish to acknowledge financial support received from the UNU/INRA and the TWOWS. They also wish to thank Mrs B. Asante (University of Ghana Legon) and Mrs P, Maartens (University of Kwa-Zulu Natal) for technical assistance.

## 6. References

- [1] Ashun MD (1996). *In vitro studies on micropropagation of various yam species (Dioscorea species)* M.Phil. Thesis submitted to University of Ghana - Legon.
- [2] Berjak, P., Mycock, DJ, Walker, M, Kioko, JI, Pammenter NW, and Wesley-Smith J (1999). Conservation of Genetic Resources Naturally occurring as recalcitrant seeds. In M. B., K.J. Bradford and J Vazquez-Ramus (eds) *Seed Biology Advances in Applications* pp. 223-228.
- [3] Berjak P, Mycock DJ, Wesley-Smith J, Dumet D. & Watt MP (1996) Strategies for *in vitro* conservation of hydrated germplasm. M. N. Normah *et al.*, (eds). *In vitro conservation of plant genetic resources* 19-52.
- [4] Berjak, P, Mycock DJ, Watt P, Wesley-Smith J and Hope B (1995). Cryopreservation of Pea (*Pisum sativum* L.). In Y.P.S. Bajaj (ed) *Biotechnology in Agriculture and Forestry* (32) Springer: 293-307.
- [5] Berjak, P, Vertucci CW and Pammenter N.W. (1993). Effects of developmental status and dehydration rate on the characteristics of water and desiccation-sensitivity in recalcitrant seeds of *Camellia sinensis*. *Seed Science Research* 3, 155-166.

- [6] Chandel, KPS, Chaudhury R & Radhamani J (1994), Biological mechanisms determining the recalcitrance in seeds of tea, cocoa and jackfruit. IBPGR-NBPGR Report.
- [7] Charoensub R, Phansiri S, Sakai A & Yongmanotchai W (1999). Cryopreservation of cassava *in vitro*-grown shoot tips cooled to -196°C by vitrification. *CryoLetters* 20, pp. 89-94.
- [8] Cho EG, Noor NM, Kim HH, Rao VR & Engelmann F (2002) Cryopreservation of *Citrus aurantifolia* seeds and embryonic axes using a desiccation protocol. *CryoLetters* 23, 309-316.
- [9] Dereuddre J, Bland S. & Hassen N (1991). Resistance of alginate-coated somatic embryos of carrot (*Daucus carota* L.) to desiccation and freezing in Liquid nitrogen: 1. Effect of Preculture. *Cryoletters* 12 pp.125-134.
- [10] Dumet D, Engelmann F, Chardrillange N, Duval Y, & Dereuddre J (1993). Importance of sucrose for the acquisition of tolerance to desiccation and cryopreservation of oil palm somatic embryos. *Cryo-Letters* 14: pp. 243-250.
- [11] Egnin M, Mora A & Prakash, C.S. (1998). Factors Enhancing *Agrobacterium tumefaciens*-Mediated Gene Transfer in Peanut (*Arachis Hypogaea* L.). *In Vitro Cellular and Developmental Biology-Plants* 34, 310-318.
- [12] Engelmann F & Engels JMM, (2002), Technologies and strategies for existing conservation. In JMM Engels, VR Rao, AHD BROWN and MT Jackson (eds), *Managing plant Genetic Diversity*, CAB International Wallingfield/IPGRI, Rome, pp 89-104.
- [13] Engelmann F, Dambier D & Ollitraut P (1994), cryopreservation of cell suspension and embryogenic callus of citrus using a simple freezing process. *Cryo-Letters* 15: pp. 53-58.
- [14] González-Arno MT, Urra C, Engelmann F, Ortiz R, & Delafe C (1999). Cryopreservation of encapsulated sugarcane apices - effect of storage-temperature and storage duration. *CryoLetters* 20, pp. 347-352.
- [15] Gonzales-Benito ME & Perez C (1994). Cryopreservation of embryonic axes of two cultivars of hazelnut (*Corylus avellana* L.). *Cryoletters*, 15, pp. 41-46
- [16] Harding K & Benson EE (1994). A study of growth, flowering, and tuberisation in plants derived from cryopreserved potato shoot-tips: implications for *in vitro* germplasm collections. *Cryo Letters* 15, 59-66.
- [17] Hatanaka T, Yasuda T, Yamaguchi T & Sakai A (1994). Direct regrowth of encapsulated somatic embryos of coffee (*Coffea canephora*) after cooling in liquid nitrogen. *Cryoletters* 15, pp. 47-52.
- [18] Jitsuyama Y, Suzuki T, Harada T & Fujikawa S (2002). Sucrose incubation increases freezing tolerance of Asparagus (*Asparagus officinalis* L) embryonic cell suspensions. *Cryoletters* 23, pp. 103-112.
- [19] Kay DE (1973) TPI Crop and Product Digest No. 2 Root CROPS. London: Tropical Products Inst.
- [20] Kioko J, Berjak P, Pammenter NW, Watt MP & Wesley-Smith J, (1998). Desiccation and cryopreservation of embryonic axes of *Trichilia dregeana* SOND. *Cryo-Letters* 19: pp. 15-26
- [21] Kioko, J, Berjak P, Pritchard H & Daws M (2000). Seeds of African pepper bark (*Wurdurgia salutaris*) can be cryopreserved after rapid dehydration in silica gel. In F. Engelmann and H. Takagi (eds.) *Cryopreservation of Tropical Germplasm, Current Research Progress and Application*. IPGRI: 371-377

- [22] Gnanaprasam, S and Vasil IK (1992). Cryopreservation of immature embryos, embryogenic callus and cell suspension cultures of gramineous species. *Plant Sciences* 83, pp. 205-215.
- [23] González-Benito ME, Prieto RM, Herradón E & Martín C (2002) Cryopreservation Of *Quercus Suber* And *Quercus Ilex* Embryonic Axes: In Vitro Culture, Desiccation And Cooling Factors *CryoLetters* 23, 283-290
- [24] Grospietsch M, Stadulkora E & Jiri Z (1999) Effect of osmotic stress on the dehydration tolerance and cryopreservation of *Solanum Tuberosum* shoot tips. *Cryoletters* 20, 339-346.
- [25] Hatanaka T, Yasuda T, Yamaguchi T & Sakai A (1994). Direct regrowth of encapsulated somatic embryos of coffee (*Coffea canephora*) after cooling in liquid nitrogen. *Cryoletters* 15, pp. 47-52.
- [26] Langis P, & Steponkus PL (1990). Cryopreservation of rye protoplast by vitrification. *Plant Physiology* 92, pp. 666-671.
- [27] Matinez-Montero ME, Gonzalez-Arnao MT, Borroso-Nordelo C, Puentes-Diez C & Engelmann F (1998) Cryopreservation of sugarcane embryogenic callus using a simple freezing process. *Cryo-Letters* 17, 171-176.
- [28] Matsumoto T, Sakai A & Nako Y (1998). A novel preculturing for enhancing the survival of *in vitro* – grown meristems of wasabi (*wasabi japonica*) cooled to -196°C by vitrification. *Cryoletters* 19, pp. 27-36.
- [29] Murashige T & Skoog E (1962) A revised medium for rapid growth and bioassays with tobacco tissue cultures. *Physiologia Plantarum* 15, 473 – 497.
- [30] Mycock D (1999). Addition of Calcium and Magnesium to a Glycerol and Sucrose cryoprotectant solution improves the quality of plant embryo recovery from cryostorage. *Cryoletters* 20, pp 77-82.
- [31] Naidoo, S, (2006). *Investigations into the Post-harvest behavior and germplasm conservation of the seed of selected Amaryllid species*. MSc Thesis University of Kwa-Zulu Natal Durban, South Africa.
- [32] Niino T, Hettiarachchi A, Takahashi J & Samarajeewa PK, (2000). Cryopreservation of lateral buds of *in vitro* grown innala plants (*Solenostemon rotundifolius*) by vitrification. *Cryoletters* 21 pp. 349 – 356.
- [33] Nishizawa, S, Sakai A, Amano Y & Matsumoto T (1993), Cryopreservation of *Asparagus (Asparagus officinalis L.)* embryogenic cells and subsequent plant regeneration by simple freezing method. *CryoLetters* 13, 379-388.
- [34] Ng SYC & Ng NQ (1991) in *Tissue Culture for Conservation of Plant Genetic Resources*, (ed) JH Dodds, Chapman and Hall, London, pp 11-39.
- [35] Ng NQ & Daniel IO (2000) in *Cryopreservation of Tropical Germplasm, Current Research Progress and Application*, (eds) F Engelmann and H Takagi, Japan International Research Centre for Agricultural Sciences, Tsukuba, Japan / International Plant Genetic Resources Institute, Rome, Italy, pp 136-139.
- [36] Pammenter NW , Vertucci CW & Berjak P (1991). Homoiohydrous (recalcitrant) seeds: dehydration, the state of water and viability characteristics in *Landolphia kirkii*. *Plant Physioplogy* 96, 1093-1098.
- [37] Panis B, Strosse H, Van Den Hende S & Swennen R (2002) Sucrose preculture to simplify cryopreservation of banana meristem cultures. *CryoLetters* 23, 375-384 (2002)
- [38] Perán R, Berjak P, Pammenter NW & Kioko JI (2006). Cryopreservation, encapsulation and promotion of shoot production of embryonic axes of a recalcitrant species *Ekerbergia capensis*, Sparrm. *Cryoletters* 27 (1), pp. 5-16.

- [39] Plessis P, Leddet C, Collas A & Dereuddre J. (1993). Cryopreservation of *Vitis Vinefera* L. Cv Chardonnay shoots tips by encapsulation-dehydration: effects of pretreatment, cooling and postculture conditions. *Cryoletters* 14, pp. 309-320.
- [40] Potts SE & Lumpkin TA (1997). Cryopreservation of Wasabi species seeds. *Cryoletters*. 18, pp.185-190.
- [41] Quain, MD, Berjak, P, Acheampong, E, and Kioko, JI, (2009) Sucrose Treatment And Explant Water Content: Critical Factors to Consider in Development of Successful Cryopreservation Protocols for Shoot Tip Explants of the Tropical Species *Dioscorea rotundata* (Yam). *CryoLetters*, 30 (3), 212-223
- [42] Reinhoud PJ, Schrijnemakers WM, van Iren F & Kijne JW (1995) vitrification and heat shock treatment improve cryopreservation of tobacco cell suspensions compared to two-step freezing. *Plant Cell Tissue and Organ Culture* 42: pp. 261-267.
- [43] Sakai A, Kobayashi S & Oiyama I (1990) Cryopreservation of nucellar cells of navel orange (*Citrus sinensis* Obs, var. *brasiliensis* Tanaka) by vitrification. *Plant Cell Report* 9, 30-33.
- [44] Santos IRI & Stushnoff C (2003) Desiccation and freezing tolerance of embryonic axes from *Citrus sinensis* (L) OSB. pretreated with sucrose. *CryoLetters* 24, 281-292.
- [45] Schippers, R.R. (2000). African Indigenous Vegetables. An Overview of the Cultivated Species. Chatham. UK: NRI/ACP-EU Technical
- [46] Shibli RA, Moges AD, and Karam NS (2004). Cryopreservation Of African Violet (*Saintpaulia Ionantha* Wendl.) Shoot Tips. *in vitro Cellular and Development Biology - plant* 40, 4, pp. 389-395(7)
- [47] Spurr A R (1969) A low-viscosity epoxy resin embedding medium for electromicroscopy. *Journal of Ultrastructure Research* 26, 31-43
- [48] Tetteh JP & Guo JI (1993) *Problems of Frafra Potato Production in Ghana*. A dissertation. School Centre for Agricultural and Rural Cooperation of Agriculture, University of Cape Coast.
- [49] Thammasiri K. (1999). Cryopreservation of embryonic axes of jackfruit. *Cryo-letters* 20, pp. 21-28.
- [50] Turner SR, Touchell DH, Senarata T, Bunn E, Tan B & Dixon KW (2001) Effect of Plant Growth Regulators on Survival and Recovery Growth Following Cryopreservation. *Cryoletters* 22, 163-174.
- [51] Veisseire P, Guerrier J & Coudret A. (1993). Cryopreservation of embryonic suspension of *Hevea brasiliensis*. *CryoLetters* 14, 295-302.
- [52] Wang J-H, Bian R-W, Zhang Y-W & Cheng H-P (2001) The dual effect of antifreeze protein on cryopreservation of rice (*Oryza sativa* L.) embryonic suspension cells. *CryoLetters* 22, 175-182.
- [53] Wang Q, Li P, Batuman Ö, Gafny R & Mawassi M., (2003). Effect of benzyladenine on recovery of cryopreserved shoot tips of grapevine and citrus *in vitro*. *CryoLetters* 24, 293-302.
- [54] Walter C, DH. Touchell, P Power, J Wesley-Smith and MF. Antolin (2002), A Cryopreservation protocol for embryos of the endangered species *Zizania texana*. *CryoLetters* 23, 291-298.
- [55] Wesley-Smith J, Vertucci CW, Berjak P, Pammenter NW & Crane J (1992) Cryopreservation of desiccation-sensitive axes of *Camellia sinensis* in relation to dehydration, freezing rate and the thermal properties of tissue water. *Journal of Plant Physiology* 140, 596-604.
- [56] Withers, LA (1985). Cryopreservation of cultured cells and protoplasts. In: K.K. Kartha (ed) *Cryopreservation of plant cells and organs*. CRC press Inc., Boca Raton. pp 243-267.

## **Part 8**

### **Equipment and Assays**



# Precision in Cryopreservation – Equipment and Control

Stephen Butler and David Pegg  
*Planer plc, University of York*  
UK

## 1. Introduction

### 1.1 Different samples may have differing cryopreservation requirements

For any cryopreservation protocol there are five key questions that govern the methodology and logistics of the freezing and storing process.

- What is to be stored?
- How many batches are to be stored?
- What is the expected duration of storage?
- What properties are the retrieved samples required to possess?
- Are there packaging requirements in addition to those dictated by the cryopreservation process?

Reduction of temperature results in the retardation of metabolic processes and this can, in some circumstances, provide sufficient stability for the required period of storage. However, at temperatures below 0 °C the biological effects of cooling are dominated by the crystallization of ice: typically, water constitutes around 80 % of tissue mass. Freezing is the conversion of liquid water to crystalline ice but the term is commonly misused in circumstances where samples are cooled below their expected freezing point but without the formation of ice, for example by supercooling or by vitrification. The result of the freezing of water in a complex solution is that the concentration of the solutes in the remaining liquid phase increases and some solutes may precipitate if their concentration exceeds their solubility limits. This realisation provides two potential mechanisms of damage: direct mechanical effects of the formation of ice, and the rise in concentration of dissolved solutes.

In 1948 a method was discovered that permitted the freezing of many types of animal cells with good post-thaw recovery of living cells: Polge, Smith, and Parkes (1948) showed in a landmark paper that adding 10-20 % of glycerol enabled avian spermatozoa to survive freezing at -80 °C. Theories of freezing injury that were current at the time envisaged ice crystals damaging the cells and intracellular structures, and because glycerol increased the total solute concentration in the system, the amount of ice that formed was reduced. A little later, in the 1950s, Lovelock (1952) showed that the increase in concentration of salts as the volume of the suspending solution decreased was in fact the dominant damaging mechanism: salt concentration, rather than ice formation, was a major cause of freezing

injury to cells. Subsequently other cryoprotectant solutes were explored along with different rates of cooling, resulting in solidification of the stored samples but with a range of mixtures of ice and vitrified solid in the stored samples.

The physical nature of the sample dictates the thermal transfer characteristics of the cooling process for that specific sample and either the physical size or cell-type will affect the appropriate cooling rate and other parameters of the cryopreservation protocol. Similarly, the physical type and ultimate intended use of the sample (for example dose requirement in the case of future therapeutic use) will determine the size of the individual packaging. An additional layer of packaging may be necessary to prevent microbiological contamination – so-called ‘double bagging’. Likewise the ultimate destination of the sample will also dictate the care required during the freezing process and the conditions necessary for long-term storage. Some tissues and most larger biological samples are currently difficult or impossible to cryopreserve successfully and new techniques, such as Liquidus Tracking (discussed later in this chapter) may address some of the problems associated with cryopreservation of these types of sample.

It is sometimes the case that the ultimate use of the samples stored is not known at the time of the initial collection and storage and sometimes the significance of particular samples may change with time. However, in many cases, the potential of the stored samples is fixed or limited at the time of selecting the cryopreservation and storage methods. The importance of these choices will be covered later; however it is pertinent to note here that the storage process may have an important impact on the value of samples when they are recovered from storage; changes in the properties of the recovered samples may be irreversible and this is therefore a key to maximising the sample's potential.

The term “viability” is frequently used in the context of cell and tissue banking. Strictly speaking it means the potential to exhibit the signs of life at some future stage, whereas it is often misused to mean the extent to which a sample demonstrates attributes of life at the present time. But that is “vitality” not “viability.” However, it is also the case that not all the attributes of life are exhibited by all living things, and the possession of one attribute does not imply the presence of them all. In fact, few of the properties that characterise “life” can be measured quantitatively. The term is best avoided; functional measurements should be named to describe what they actually measure: membrane integrity; a specified metabolic function; ability to reproduce. In addition there are obvious cases where the tissue does not have to be alive in order to function; in bone for example. But equally, in many cases fully functional survival is paramount; the haemopoietic stem cells in cord blood will not graft in the recipient if the cell concentration is lower than a threshold value. In such cases a low total recovery of living cells in the thawed sample will limit the use of the thawed sample. Another common situation is where samples are stored in order to ensure that a supply of identical cells will be available throughout a long-term study. Although it is possible to regrow new cell batches from recovered samples, repeating this process can lead to progressive degradation due to mutations.

## **1.2 The physics of freezing**

The process of freezing is ultimately simple; it is merely the application of an environment that removes energy from the sample over a period of time and changes the physical state of



water in the sample from liquid to crystalline. Crystalline water (ice) excludes the solutes previously dissolved in the water, resulting in two potentially dangerous mechanisms – direct effects of ice and secondary effects in the solute composition. At a sufficiently low temperature all biological activity is prevented and the physical state of the sample is preserved. In simple cases, where the only requirement is to preserve the physical state or where cellular structure is absent (viruses, DNA etc.), that is the end of the story; physical deterioration can be prevented at relatively high temperatures, and in many institutions worldwide this task is completed in the banks of -80 °C refrigeration units that proliferate in medical and biological research establishments.

The preservation of living cells and tissues and the post-thaw ability of cells to proliferate and thrive are determined by a number of factors: the laboratory techniques and the thermodynamic processes that a sample experiences during processing and freezing; the environment in which it resides between freezing and the ultimate use post-thaw. The potential of many samples is severely limited at this stage by the choices made by, or enforced upon, the technician regarding the freezing protocol. It may be that some stored samples lose significant value due simply to the omission of a few simple additional steps.

The cryopreservation process has two main aims. The first is to reduce the temperature of the sample to a point where biological stability is achieved. The application of an external cryogenic environment will remove energy from the sample and create a very low-energy solid state within which biological and chemical activity are limited or prevented altogether. The second is that during the freezing process it is necessary to prevent the formation of intracellular ice crystals: such crystals damage the cellular structure and can lead to limited post-thaw recovery and post-thaw failure of the cell sample to function as required. Additionally, the protocol must take into account the stresses to which the cells are exposed during the freezing process (dehydration, hypothermia, chemical toxicity, and solute concentration) and the potential for an apoptotic response post-thaw.

The objective, therefore, is to create an environment in which, as the sample is cooled, the chemical composition inside the cell, is managed in such a way as to create an intracellular composition with a lower freezing point than the applied environment, whilst maintaining an external suspending composition that is able to solidify at the same temperature. The balance between the internal and external environment is managed chemically via the solutes in the micro-environment and thermodynamically via the application of an energy reducing (cooling) macro-environment. It is the combined action of these two factors that determines the success or otherwise of a cryopreservation protocol for the conservation of vitality.

The appropriate solute composition is created by including cryoprotective agents (CPAs) in the medium. These operate in one of two ways: either they modify the extracellular composition or alternatively they also replace some of the intracellular water. The first mechanism involves the addition of non-penetrating CPAs such as trehalose, polyethylene glycol (PEG) or Polyvinyl-pyrrolidone (PVP), to the medium. The second mechanism requires the addition of penetrating solutes that can traverse the cell membrane, such as glycerol, ethylene glycol and dimethyl sulphoxide (DMSO). Since water does not retain solutes when it freezes, a solution at equilibrium with ice will vary in osmotic potential as it freezes and because of this, the micro-environment of a cell will require either the cell to lose water to the environment or exchange water for CPA molecules, thereby maintaining

osmotic balance. The concentration of intracellular material lowers the effective freezing point of intracellular material and, provided the external temperature is correctly managed, prevents the formation of intracellular ice. As such, the creation of ice crystals within the cell is avoided. At temperatures below  $-130\text{ }^{\circ}\text{C}$  (close to the glass transition temperature of the medium) the residual liquid has too little energy to orientate into long range molecular matrices and will form short range semi-solid structures; i.e. an amorphous solid or glass. At this point there is no possibility for significant chemical transport; biological activity, and hence deterioration, effectively ceases.

The options for control of this process are the chosen CPA and its concentration, and the cooling rate. Water and solute permeability are temperature dependent and nominally the higher the concentration of extracellular CPA, the less ice will form during cooling. With a very high applied concentration of CPA, very rapid cooling without the formation of ice may be possible – a process that is known as vitrification. At the other extreme, lower CPA concentrations that allow ice to form, require more precisely managed cooling rates which can be provided by programmable controlled rate freezers. The issue here is the toxicity of the applied CPA since high concentrations, even for short periods, can lead to excessive dehydration and high cell stress, whereas lower concentrations may involve prolonged cellular exposure to essentially toxic material. DMSO, for example, is an organic solvent and has been linked to cellular mutation. The choices made for the preparation and subsequent freezing of cells is a complex balance between thermodynamic and biochemical variables, the choice and management of which can have a profound effect on the post-thaw recovery of living cells and hence the value of the sample.

### 1.3 Long term cell survival and contamination

All biological materials will, without intervention, naturally deteriorate, and if they are to be preserved it is necessary to utilize a method that will preserve both morphology and functionality while preventing any alteration of the fundamental nature of the material. The most common methodology available for this is cryopreservation. Biological materials, however, have widely different properties and in order to create a truly effective cryopreservation protocol, it is necessary to consider these properties as they affect the preservation of vital characteristics both during the freezing process and the subsequent environment in which the samples are to be stored long term.

Regarding the minimum storage temperature, no temperature is too cold. Once a sample is frozen and the residual liquid phase has vitrified, further cooling simply reduces molecular energy and vibration. It is possible for short-range structural changes to occur at a molecular level, but they do not affect post-thaw biological properties. It is worth noting that because the cell micro-environment within a frozen sample is chemically different from the majority of the frozen material, biological activity may continue, albeit slowly, at temperatures several degrees below the freezing point of the material.

The minimum melting point of the multi-dimensional phase diagram for typical cryopreservation media occurs at around  $-80\text{ }^{\circ}\text{C}$  but the cell contents do not finally solidify to an amorphous state until around  $-120\text{ }^{\circ}\text{C}$ . It is not sufficient simply to keep the samples frozen because, at a micro-environmental level, if the material retains the ability to diffuse it may also degrade, albeit at a much reduced rate. The glass transition temperature is therefore regarded as the “critical” temperature if truly long term storage is required

Best practice dictates that freezers should maintain sample temperatures as far as possible below this critical temperature. By storing well below the critical temperature, transitory warming events above that temperature can be avoided during sample handling, retrieval, storage and in the event of any disruption to the availability of cryogen or power. Freezing a sample in such a way as to maintain maximum biological potential is not a trivial task, and the same care applied to this process should be brought to bear when designing and building storage environments.

The key considerations when looking at a cryopreservation process were listed at the beginning of this chapter. Clearly, the process should be able to maximise the potential for use after processing and storage. Because the future use may be unclear, the preservation and storage procedures should be designed to provide the best possible opportunity for future exploitation. The storage of cells without either adequate care during the initial cryopreservation process or at too high a temperature during subsequent long-term storage are key problems that should be avoided and when the purpose of storage is to maintain biological potential, it is vital that the mechanism of freezing injury be considered.

As the liquid in which the cells are suspended begins to freeze, any solutes in the unfrozen solution become more concentrated and this results in a depression of the freezing point of the remaining solution. The result of this, when the temperature is reduced, is that the cells are exposed to a solution of progressively higher concentration. The increasing concentration increases the osmotic gradient across the cell membrane which results in water leaving the cell in order to maintain balance. Hence, controlling the cooling rate provides a mechanism for controlled dehydration of the cells. Eventually the aqueous phase is so viscous that there is insufficient energy available for the water molecules to form a crystalline solid and the solution becomes an amorphous solid or glass. The temperature at which this condition is reached is known as the “glass transition” temperature ( $T_g$ ). Once the sample is below this temperature, diffusion within and without the cell stops and the sample is biologically inert. At temperatures below  $T_g$  the sample can be maintained indefinitely; other physical interactions, such as background radiation, may have an impact on extremely long-term storage but such effects are probably without any significance in practice (Glenister et. al., 1984).

Unlike freezing, the glass transition is not based upon a thermodynamically defined phase change but rather on the observed dramatic change in viscosity that occurs in cryoprotectant solutions typically at around  $-120\text{ }^\circ\text{C}$ . It is important to ensure that samples are maintained below this temperature throughout the storage term. A temperature of  $-150\text{ }^\circ\text{C}$  is typically stated to be the critical storage temperature for cell products since this temperature provides a reasonable safety margin to ensure that that samples remain below the glass transition temperature during transitory events such as handling, but in practice, storage in liquid nitrogen at  $-196\text{ }^\circ\text{C}$  is a convenient and reliable way to meet this requirement; moreover the additional safety margin provides even greater sample security.

However, storage in liquid nitrogen is not without its disadvantages which include the risk of explosion during warming should liquid nitrogen have entered the vials. Microbiological cross-contamination is another hazard of storage in liquid nitrogen (Byers, 1999) and may lead to the application of a secondary enclosure (‘double bagging’). Storage in the gas phase has been advocated to avoid these problems. In the past, the temperature gradient in the vapour phase of liquid nitrogen refrigerators has been a problem, and there may have been

increased vulnerability to inadequate amounts of liquid nitrogen between refills. Modern high-efficiency liquid nitrogen cooled vessels now allow storage in the vapour phase without these problems. These vessels are vacuum insulated and the surface area that is not insulated by the vacuum is minimised ensuring that the evaporation rate of liquid nitrogen is kept low. Restricting the amount of energy entering the vessel ensures that the temperature in the vapour phase is maintained close to the liquid nitrogen temperature. The upper region of the refrigerator, close to its access point where the temperature would otherwise be higher, can be efficiently cooled if it is ensured that the heat exchange surface extends right from the bottom to the top of the refrigerator: gas phase temperatures of around -190 °C can be achieved.

The weak point in the process of maintaining safe low temperatures for samples focuses on the time in transport to and from its storage. Small samples of low thermal mass, such as vitrified straws, can warm at the rate of thousands of degrees Celsius per minute and regulatory inspections requiring the removal of samples for identification can be another weak point.

#### **1.4 Traceability**

Under most regulatory environments, a rigorous sample tracking system is a key and mandatory component of compliance. It is vital that the individual location of any sample is recorded accurately, and that the sample is labelled with a unique identifier such that the identity of a sample at any location can be verified. For many research and therapy provision operations it is also necessary to have all processing, analytical and, if relevant, patient data linked in a central database.

Labelling can be a challenge as sample containers can be small and the cryogenic environment hostile; however commercially available cryogenic-proof labels and label printing systems are readily available. RFID tags are also a promising solution.

Sample location databases should be organized hierarchically, such that the location of any individual sample can be readily identified; for example: Room / Freezer / Shelf; or Segment / Rack / Position of Box in Rack / position of Vial in Box; or Room / Freezer / Canister / Cane / Goblet / Straw position in Goblet.

Most regulatory environments require the label to include both machine and human readable identifiers (bar code plus text) and where a sample is stored in a secondary container (such as a blood bag in a cassette) it is vital that both the external container and the primary sample container be correctly labelled; see for example the European Directives 2004/23/EC and 2006/86/EC

Concomitant with good identification procedures are good location and retrieval methods and there are a number of commercial software systems available with varying degrees of sophistication to accommodate larger or smaller numbers of stored samples. However an often overlooked part of the storage process is the logging, monitoring and associated alarms. Recording the parameters of storage is sometimes seen only as a regulatory obligation but liquid nitrogen levels or temperatures and the performance of mechanical freezers is of front-line importance. Alarms that work in practice rather than in theory are vital additions to a comprehensive storage environment.

## 2. Types of technique

There are various options to consider when choosing the methodology and equipment for the cooling process. In conventional cryopreservation, where the intention is to control the rate of formation of ice in the material, it is necessary either to vary the rate of application of a cryogen when working against a constant warm environment, or to provide insulation or energy while maintaining a constant external cold environment. If insulation is used, the cooling rate at any point is approximately proportional to the difference in temperature between the sample and the environment as modified by the insulation and the change in specific heat of the sample as cooling proceeds. Thus, during the process, the cooling rate asymptotically approaches zero as thermal equilibrium is achieved. Applying variable energy to a sample in a cold environment allows the rate of cooling to be modified during the process. The aim is to maintain a composition within the cells that varies as cooling proceeds such that its freezing point remains below the applied environmental temperature. Alternatively, if the concentration of cryoprotectant is high enough, it may be possible to cool the sample sufficiently rapidly that ice cannot form – an approach called vitrification. The required cooling rate will depend on the cryoprotectant and its concentration, the latter being dependant on the concentration that the cells will tolerate. In general, very rapid but uncontrolled cooling is used. The new technique of liquidus tracking allows slow cooling and vitrification.

### 2.1 Freezing in mechanical freezers

Passive cooling uses insulation to moderate the cooling rate of samples that have been equilibrated with low concentrations of cryoprotectant and then placed inside traditional electromechanical refrigerators at  $-20\text{ }^{\circ}\text{C}$ ,  $-40\text{ }^{\circ}\text{C}$ ,  $-80\text{ }^{\circ}\text{C}$  or even at lower temperatures. The cells are dessicated slowly during the cooling process. This method can be used for most robust cells but even under the best circumstances the post-thaw recovery rates may not be ideal. In addition, in most cases no instrumentation monitoring or recording of the process is provided. The variation of temperature within mechanical refrigerators is well known with one study reporting values of  $-43.5\text{ }^{\circ}\text{C}$  to  $-90\text{ }^{\circ}\text{C}$  in upright freezers (Su et. al., 1996). Since there is no active control during the process, it follows that the poor repeatability of the process can affect the cooling rate and hence the efficiency of the whole procedure. Variability might be improved if the local environment were more stable and protected from instantaneous variation due to external factors such as door openings etc. It is generally preferable to use a liquid nitrogen gas phase freezer for this approach since the internal temperature variation is small and the environment disturbed less frequently.

This approach to cooling and freezing is increasingly being used for material provision in pharmaceutical drug screening programmes as they move from supply by continuous culture towards a “cells-as-reagents” concept. In this approach, the cells are insulated in polystyrene containers as they are cooled initially to  $-80\text{ }^{\circ}\text{C}$  and then transferred for cryogenic storage into liquid or vapour phase nitrogen. The need for rapid use of the cells for drug assays following cryopreservation, places an increased importance on the post-thaw quality of the cells. In recent work carried out at LGC (Teddington,UK) this has been shown to be compromised by this type of freezing where the cooling rates are not actively controlled but rely on the passive characteristics of the system. In particular, temperature fluctuations within the polystyrene container and the storage time at  $-80\text{ }^{\circ}\text{C}$  can significantly impact the post-thaw recovery of the cells and their biological function.

## 2.2 Controlled freezing, protocols and seeding

Liquid nitrogen may be applied via a pressurised supply and cryogenic valve to create a very accurate cooling profile of temperature over time. This methodology offers the most options for optimization since the cooling rate can be varied at multiple stages in the process. As freezing proceeds the concentration of solutes in the medium increases causing cell dehydration in the sample.

As described in the opening section, cooling protocols are designed to manage the intracellular solute concentration. The key point is the nucleation temperature of the suspending medium - that is, the temperature at which ice starts to form. The ice is extracellular, resulting in an increase in the extracellular solute concentration and hence an osmotic pressure difference between the intracellular and the extracellular solutions that leads to the withdrawal of water from the cells. It is important to recognize that under normal circumstances, solutions do not freeze at their freezing point; they freeze at their nucleation temperature, which is variable and depends on the availability of nucleation centres in the sample. The nucleation temperature is normally several degrees below the nominal freezing point.

Once the extracellular fluid begins to freeze, two major events occur. First, as explained above, the concentration of CPA increases in the fraction of the extracellular fluid that has not at this point frozen, and this causes the cells to dehydrate. Secondly, the temperature of the suspension where freezing has commenced rises towards the nominal freezing temperature and remains at or close to this temperature until the freezing process is complete. This is followed by a drop in temperature as the sample catches up with the temperature of the surrounding medium, but if the cooling rate is too rapid the intracellular CPA concentration may be insufficient to prevent intracellular freezing - with severe consequences for the cells

In order to avoid this hazard, the control program may be designed to allow equilibration of the sample and its suspending medium at a temperature marginally below the calculated freezing point and at this temperature the sample forced to begin to freeze by applying either a physical nucleation point via a cold instrument placed on the external wall of the sample container, or via a sudden, short-lived introduction of cryogen into the environment. This causes the sample to commence freezing. As the sample was originally held only marginally below the nominal fusion temperature, the cell experiences a much more moderate reduction in temperature when the fusion is complete and the temperatures re-equilibrate. After this, the cooling processes is started and continues with a temperature program that is designed to effect the necessary concentration changes to maintain the intracellular composition in the liquid region of the phase diagram. This process is called "seeding".

## 2.3 Vitrification

The process of vitrification usually uses the highest concentration of cryoprotectant that the cells in the tissue will tolerate and follows this by very rapid but uncontrolled cooling, usually by plunging the sample into liquid nitrogen. The crucial element is exposure of the cells or tissue to potentially toxic levels of CPA: too low a level or too short a time and ice will form killing the cells. If the levels are too high or the process time is too long, the chemicals employed will prove toxic to the cell and post-thaw viability will be limited. Since this process depends on rapid cooling, vitrification has only ever proven applicable for

samples with very small volumes, ideally those with very high surface area-to-volume ratios; for example cryogenic straws can fit this description. It is important to be aware of the Leidenfrost effect where a sheath of vapour will surround a warm sample when plunged into liquid cryogen, essentially insulating the sample for a short period of time. For many vitrification protocols however, even this short additional time period before the sample is vitrified has proven fatal to the cells due to increased toxic exposure to the CPA and decreased cooling rates. In conventional vitrification, very high cooling rates are achieved by exposing small samples directly to the liquid nitrogen. The sample is surrounded with as little physical material as possible to achieve the maximum cooling rates. With large samples, however, such high cooling rates are impracticable.

Although vitrification is normally associated with cooling rates in the tens of thousands of degrees Celsius per minute, slower techniques have been reported such as the S3 vitrification technique for blastocysts (Stachecki & Chen, 2008); this uses rates <200 °C/minute. But in fact vitrification does not necessarily require rapid cooling at all. It all depends on the dependence of the critical cooling rate required to prevent freezing on the concentration of the cryoprotectant. (Sutton, 1991). As the following section describes, vitrification can be produced at really low cooling rates.

## **2.4 Warming and thawing**

It is usual to thaw cryopreserved or vitrified samples rapidly – typically by plunging them in a 37 °C water bath. The warming rate does have an effect on the recovery of living cells but this is not as great an influence as cooling rate is during cooling. In fact, optimum cooling rates have usually been determined using rapid warming so it is hardly surprising that rapid warming then gives the highest recovery! However, there are circumstances when the warming rate is of importance in its own right. The first is when the sample has been vitrified but is nucleated without a significant amount of ice being present. This is an unstable situation and in such circumstances the warming must be rapid to avoid intracellular freezing during warming. This consideration argues for rapid warming. The other situation occurs when the frozen material contains a significant amount of vitrified material, as is always the case in conventional cryopreservation. Glasses are brittle and the hazard here is that rapid warming will generate thermal stresses and cause the vitreous material to fracture. This will not matter greatly with cell suspensions where a fracture running through the sample is unlikely to traverse many cells but it is very important when the extracellular matrix must be intact – as it must, for example, in grafted blood vessels and heart valves. The solution here is to warm through the vitreous zone, that is from -196 °C to -123 °C, relatively slowly: once above the T<sub>g</sub> there is no hazard from fractures and the sample can be warmed as rapidly as you like. A convenient way to do this is to allow the sample to warm slowly in a -80 °C refrigerator or packed in solid CO<sub>2</sub> until its temperature is at above -100 °C. Alternatively the sample can be surrounded by a layer of insulation during the initial stage of warming in room air. A warming rate of around 50 °C/minute up to -100 °C was ‘slow’ enough to prevent fractures in cryopreserved rabbit carotid arteries (Pegg et al., 1997).

## **2.5 Liquidus tracking – A new method**

The controlled-rate freezing process achieves its results by preventing the formation of intracellular ice. In some samples, however, even extracellular ice can be severely damaging.

An example of this is articular cartilage. Isolated chondrocytes can be cryopreserved using conventional techniques (Pegg et. al., 2006a) but results when attempting to cryopreserve chondrocytes in situ have proven to be very disappointing. It was found that traditional cryopreservation results in the formation of ice crystals within the chondrons and not just in the acellular matrix (Pegg et. al., 2006b) which might have been expected from experience with conventional cryopreservation. In articular cartilage it is important to prevent both intracellular and extracellular ice. With this requirement in mind, the most appropriate cryopreservation approach would appear to be vitrification; that is the prevention of any ice formation at all. However, it will be clear that conventional vitrification is out of the question because of the heat transfer problems with bulky samples. Liquidus tracking (LT) provides a new approach to this problem.

During conventional cryopreservation, with a moderate concentration of CPA (say 10 %w/w) and relatively slow cooling (say 1 °C/minute), the cells are exposed to gradually increasing concentrations of cryoprotectant as progressively more extracellular ice is formed. The instantaneous CPA concentration is determined by the temperature according to the phase diagram of that specific system. The idea of LT is to control the instantaneous concentration of CPA throughout the cooling process so that the CPA concentration follows the liquidus line by external control rather than by progressive freezing of the medium. In this way the medium remains just above its freezing point at all times and no ice is formed. It is important to note that the cells are exposed only to the concentrations of CPA that they would experience during conventional cryopreservation. And we know that isolated chondrocytes in suspension can be cryopreserved by standard methods. In effect, the LT process takes advantage of the decrease in cytotoxicity of cryoprotectants as the temperature is decreased: hence, rather than starting with a very high concentration of cryoprotectant, the LT approach controls the concentration dynamically throughout the cooling process. In this way, vitrification can be achieved without using the extremely high concentrations of cryoprotectant at the start of the process and without the need for rapid cooling. Of course, allowance has to be made for the time that diffusion of CPA into the tissue takes and this can be very considerable. On the other hand, if an organ can be perfused with the cryoprotectant solution, via the vascular system during cooling, then the diffusion distances will be very short and mass transport delays much less significant. In practice, when designing an LT process for a particular tissue, it is crucial to determine the concentration that is actually achieved in the tissue as the process continues and to adjust the concentration/ temperature/ time program to achieve the desired tissue concentration at all stages of the process. This necessitates slow cooling, commonly of the order of 0.1 to 0.3 °C per minute. The cooling of the samples can be achieved in a conventional controlled rate cooler and the solution composition can be controlled by standard peristaltic pumps, the whole system being under computer control – see section 3.7 below for a discussion of the methods that are now available for research use.

### **3. Types of equipment**

Due to the many different types of samples that can be cryopreserved and their differing sensitivities, a number of different techniques and types of equipment are used.

#### **3.1 Minus 80 °C and lower: Mechanical freezers**

Mechanical refrigeration always applies the same methods no matter the degree of cooling desired: a gas is passed through a compression system and liquefied. The energy which is



released during this liquefaction is dissipated to the environment via heat exchanger coils. The liquid is then passed through cooling coils within the freezer chamber and absorbs energy from the chamber as it vaporizes. It is the vaporization process that creates the cooling effect. As lower temperatures are required, lower liquid point gases must be employed. In order to liquefy these gases, higher pressures are required and often the liquefaction cannot be completed in a single process; this results in larger, multiple compressors being employed.

The most commonly used freezers for cryogenic purposes are upright, front-opening freezers with a cold point at a nominal  $-80\text{ }^{\circ}\text{C}$ . It should be noted that there is no biological significance for this temperature, merely a physical significance since it approximates to the sublimation temperature of dry ice (solid carbon dioxide,  $-79\text{ }^{\circ}\text{C}$ ). This type of freezer can be employed to store biomaterial in which living cells are not a prime concern, or when it is to be stored for only a short period of time. This type of equipment is intended to be for transactional storage – holding material required daily and which will either be consumed or transferred to more appropriate conditions within a short time - 6 to 12 weeks typically.

The front opening design, while adding considerable convenience, creates a significant issue with temperature stability and variability. Because cold air is significantly heavier than warm air, opening the door causes massive air exchanges and temperature rises in the sample area in a short period of time. In addition, because the compressor systems run on a very high cycle time, there is little spare capacity to effect a cooling after the temperature has risen and it can take some time to return to equilibrium after a warming event. This property is similarly exhibited when the freezer is in normal operation and as has been previously noted, there can be significant temperature variations. The use of deep drawers within the refrigerator for the storage of samples is helpful in reducing the loss of cold air when the door is opened.

Because of the high cycle times, compressor failures are quite common and expensive to repair. It should also be noted that as the energy removed from the sample area is 100 % dissipated into the room in which the freezer is located, the term cost of operating a unit such as this should take into account not only the electricity consumption required for the compressor system, but also the significant air conditioning costs associated with the expelled heat from the freezers. If this energy is not removed by air-conditioning, the freezers become less efficient as room temperature rises, compressors are required to cycle even longer, power usage rises and compressors fail more quickly. Environmental management at a macro as well as micro level is therefore important.

### **3.2 Alcohol bath freezers**

These commonly used laboratory units are essentially refrigerated circulators. A reservoir of cooling medium (normally an alcohol) is passed through a cooling system and re-enters a reservoir, reducing the temperature. The degree of refrigeration applied and the flow rate through the cooling coils determine the derived temperature of the reservoir. The relatively large volume of cooling liquid creates two noticeable effects: temperatures are very stable due to the large heat capacity of the available fluid and cooling rates can be controlled very accurately for a similar reason. The corollary to this however is that the rates achievable are very low and so rapid ( $> 1\text{ }^{\circ}\text{C}/\text{minute}$ ) rates are very hard to achieve. In addition, alcohol bath freezers are normally limited to temperatures above  $-80\text{ }^{\circ}\text{C}$ .

### 3.3 Liquid nitrogen vessels: Liquid and vapour

Storage of important biomaterial in liquid nitrogen at  $-196\text{ }^{\circ}\text{C}$  is widely practised. This method allows for a  $70\text{ }^{\circ}\text{C}$  plus safety zone when considering the  $-120\text{ }^{\circ}\text{C}$  threshold for long-term storage; the significance of  $-120\text{ }^{\circ}\text{C}$ , the glass transition temperature, has been previously discussed. Liquid nitrogen storage does provide the greatest safety zone. However, it also presents a number of problems, including personal safety and potential microbiological cross-contamination via the liquid nitrogen.

Storage in the vapour stage is felt to address these issues but it does come with its own set of problems. The vapour is not as cold as the liquid nitrogen itself and as such the  $70\text{ }^{\circ}\text{C}$  safety margin is diminished. However, modern vapour storage vessels use carefully designed vacuum insulation to minimise the heat leakage from the environment into the vessel. This allows the vessel to maintain a vapour temperature at around  $-190\text{ }^{\circ}\text{C}$  resulting in samples still being maintained at a safe distance from the glass transition temperature. Efficient designs also result in very low liquid nitrogen usage and temperatures can be maintained for up to a month without additional filling; temperatures are even maintained with the lid removed for short periods.

### 3.4 Controlled rate liquid nitrogen freezers

As described previously, up to present times, the controlled rate freezer offers the widest control options for a freezing protocol. With a truly variable application system for cryogen, most sample sizes can be easily accommodated and rates from the very slow ( $< 0.1\text{ }^{\circ}\text{C}/\text{minute}$ ) to in excess of  $50\text{ }^{\circ}\text{C}/\text{minute}$  are both achievable and controllable. Sample size, container dimension, cell volume, membrane permeability etc. are all variable factors. As the controlled-rate freezer allows complex, fully controlled temperature versus time profiles to be created, protocols can be designed that are appropriate to the cell type and cryoprotectant concentration. Additional steps such as pauses for manual 'seeding' or rapid plunges to initiated freezing can be added to the profile. Transition to different rates can be triggered from the chamber temperature or representative sample; triggering the transition from the sample temperature can help remove variability introduced by different sample loads.

From an instrumentation standpoint, the programming and record-keeping intrinsic within the system meet most external compliance standards and optional software packages are generally available to enhance this aspect beyond the current requirements of any legislative authority. The fact that it is possible to optimise processes for every unique cell type together with the compliance aspect lend great versatility to this type of instrument in most application areas.

### 3.5 Equipment for conventional (high cooling rate) vitrification

Such protocols call for extremely rapid solidification of the sample, typically by plunging it directly, and in a somewhat uncontrolled manner, into liquid nitrogen. Intracellular ice formation is avoided by the application of very high concentrations of CPA. Equipment such as the VitMaster (IMT Ltd.) can be used to increase the cooling rate. This uses negative pressure to depress the freezing point of liquid nitrogen to below  $-205\text{ }^{\circ}\text{C}$  thereby increasing the cooling rate. Several open techniques have been developed to minimise the sample volume and achieve high cooling rates; for example the Cryotop method which uses a thin

film strip to hold the sample. These open systems typically expose the sample directly to the liquid nitrogen which assists in achieving the very high cooling rates. Of course exposing the sample directly to liquid nitrogen in this manner raises questions of potential contamination from the cryogen. Other approaches, such as the Cryologic Vitrification Method, still use an open device at the stage of vitrification but cool the sample by touching on a liquid nitrogen cooled aluminium block. This means that the sample is not directly exposed to the liquid nitrogen and the block avoids the Leidenfrost effect. Alternative approaches use closed straws. These avoid the contamination issues but at the expense of the cooling rate. By definition, the vitrification stage of the process is difficult to measure, monitor or document, so validation and on-going quality control are qualitative exercises only.

### 3.6 Stirling engines

Originally conceived in 1816 by the Reverend Stirling, the Stirling engine converts heat energy into mechanical work. The principal also works the other way round to convert mechanical energy to heat, when the Stirling engine forms a heat pump able to move heat 'uphill' from a cold place to a warmer one. This gives the Stirling engine an application as a refrigeration unit.

Most refrigerators operate on the Rankine cycle which depends on refrigerants existing with appropriate boiling points. Triple stage Rankine machines are at the limit of the technology and achieve roughly  $-140^{\circ}\text{C}$ . Although the Stirling cycle is less efficient than Rankine cycle machines, it is capable of cooling to lower temperatures and therefore comes into its own below  $-140^{\circ}\text{C}$ ; miniature cryo-coolers based on Stirling engines are now quite common. Due to relative inefficiency, these Stirling based cryo-coolers can normally freeze only quite small samples of a few tens of grams maximum and cannot compete with liquid nitrogen powered machines for cooling capacity. On the other hand, they excel in clean rooms where it is not possible to obtain a supply of liquid nitrogen and it is only desired to freeze very small samples.

### 3.7 Liquidus tracking equipment

Because liquidus tracking is a relatively novel technique, there is little choice of equipment to assist with research into its use. Planer plc do manufacture a Liquidus Tracking controller that can be used for research into this approach. The equipment comprises a conventional slow-rate chamber coupled with a liquidus tracking controller and two peristaltic pumps.

The controller cools the sample in a similar manner to the conventional slow-rate freezing process. The cooling profile is typically a simple linear ramp. During the cooling of the sample, the controller monitors the current chamber temperature and adjusts the speeds of the two pumps to dynamically alter the concentration of cryoprotectant surrounding the samples. In the ideal process the concentration of cryoprotectant is maintained just above the liquidus curve. As the temperature decreases, the concentration of cryoprotectant is therefore increased. However, as the temperature of the sample decreases, the toxicity of the cryoprotectant decreases and this allows the sample to tolerate the ever increasing concentrations; see figure 1.

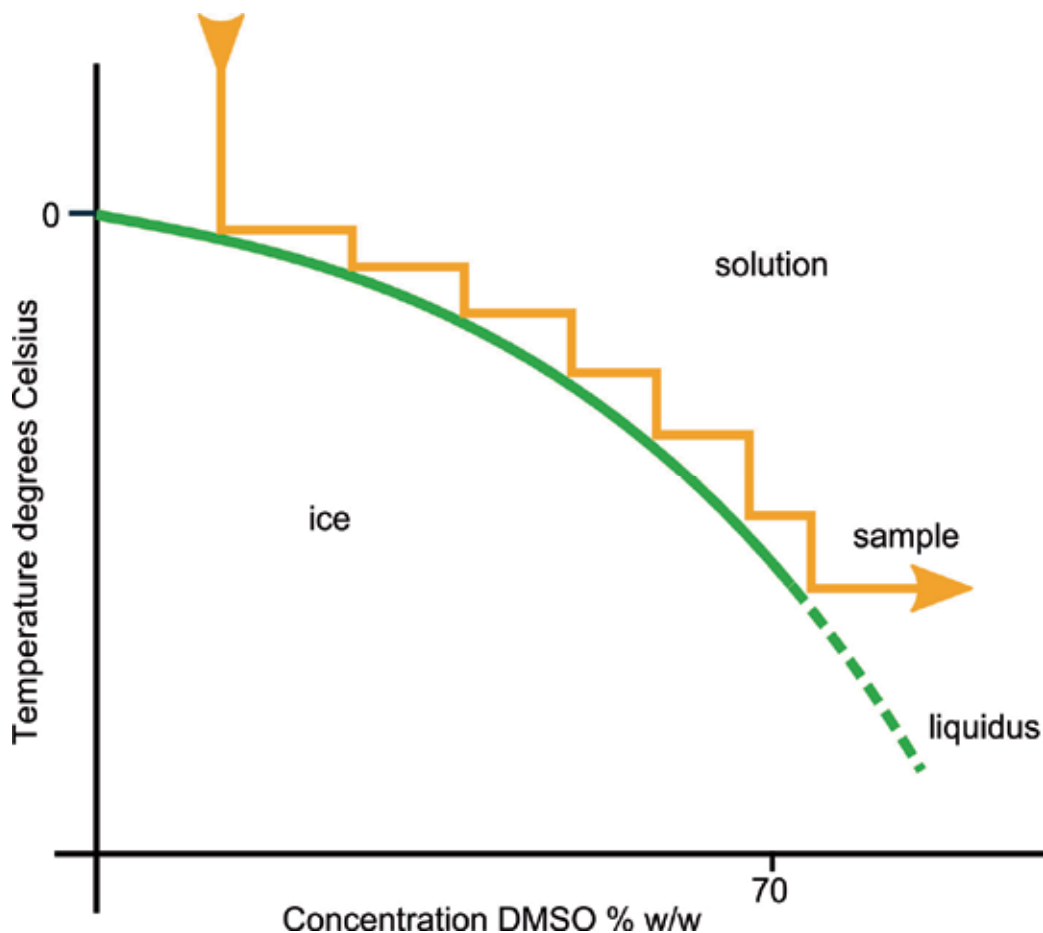

Fig. 1. Concentration of sample tracking liquidus

Two specific requirements of this process are the rather large volumes of cryoprotectant required and the need to ensure good mixing around the sample. The Planer Liquidus Tracker supports two modes of operation each with its own advantages and disadvantages; these are the single solution and dual solution modes.

In the dual solution mode, shown in figure 2, a solution containing a high concentration of CPA (typically 72 % w/w DMSO plus isotonic salts) and a solution containing only isotonic salts (nominal 0 % solution) are used. Each solution is pumped through a mixing junction and a heat exchanger into the sample container and thence into a waste collection container. The relative speeds of the pumps are continuously adjusted via a computer program to deliver the correct concentration to the sample. The pump speeds are adjusted to maintain a constant flow rate through the sample container. The dual solution system requires a small volume surrounding the sample so that the incoming, premixed solution is able to displace the existing solution completely as it flows through the container. The total volume of cryoprotectant can be quite large; for example, a run from 0 °C to -70 °C at 0.3 °C/minute requires a total volume of solution equal to 233 times the sample container volume. This

method is suitable for use with small sample containers and has been used for discs of ovine articular cartilage ( see Wang et al., 2007).

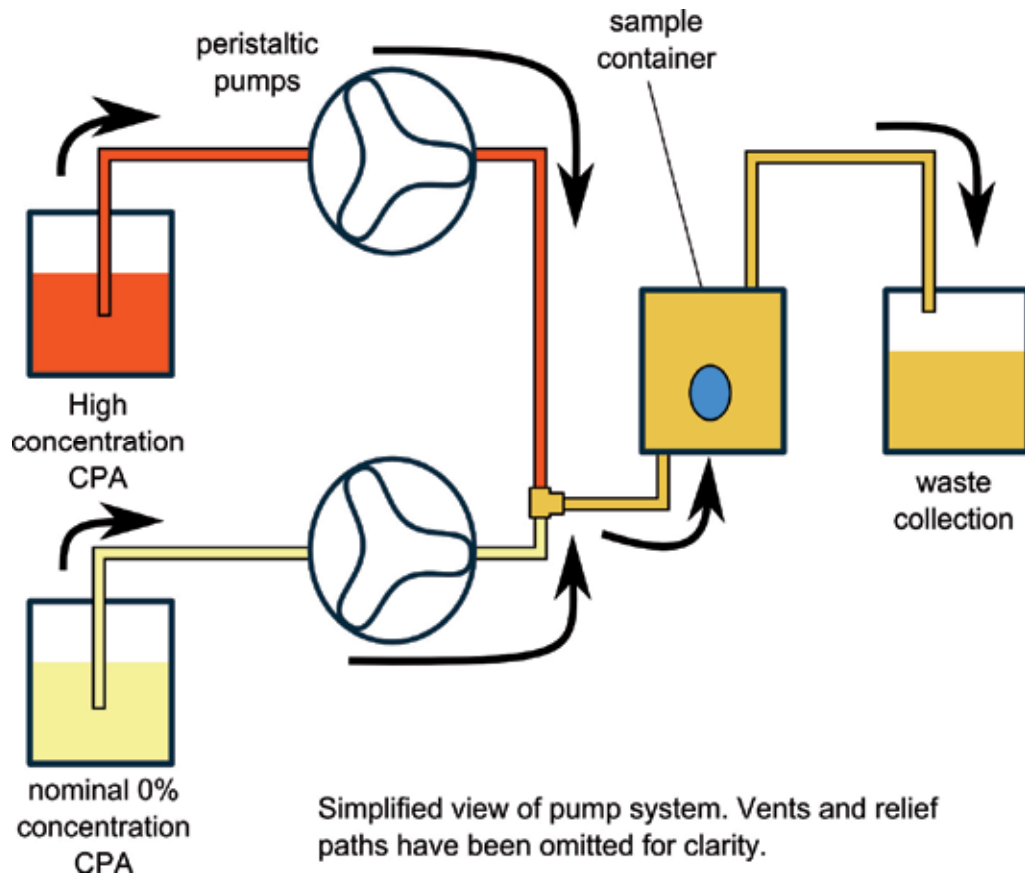
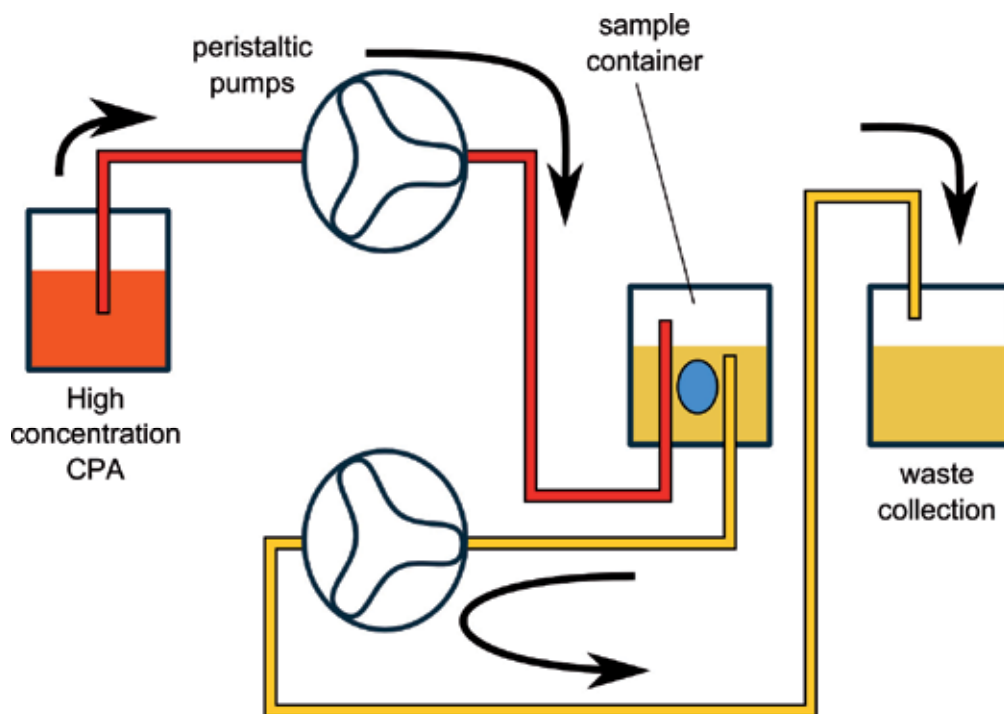

Fig. 2. Dual solution mode.

The single solution mode is more suitable for use with larger samples. It is illustrated in figure 3. Here a highly concentrated solution is cooled and delivered to the sample container. This increases the concentration of the CPA solution surrounding the sample. To maintain a constant volume within the container, the second pump extracts the excess solution from the container. This technique is suitable for larger samples as it reduces the total volume of cryoprotectant required. For a sample container volume of  $V_s$ , a cryoprotectant concentration of  $K_{sol}$  and a target concentration of  $K_t$ , the volume of cryoprotectant  $V$  can be calculated from this equation.

$$V = V_s \ln(K_{sol} / (K_{sol} - k_t)) \quad (1)$$

For a sample container volume of 50 ml, depending on the actual values of  $K_{sol}$  and  $K_t$  this approach could require less than 100 ml of concentrated DMSO solution. Because the incoming solution has to be thoroughly mixed within the container, additional stirring equipment running at cryogenic temperatures is required. This results in a mechanically more complex arrangement than the dual solution approach.



Simplified view of pump system. Vents and relief paths have been omitted for clarity.

Fig. 3. Single solution mode.

### 3.8 Examples of equipment used

The BioCool Controlled Rate Freezer from FTS Systems/SP Scientific is a mechanically refrigerated bath with temperature control to  $-40^{\circ}\text{C}$  or  $-80^{\circ}\text{C}$ . The fluid in the 2 litre bath provides temperature stability and dispersion of the heat of fusion without a concomitant temperature rise. Courtesy SP Scientific and Gary Gold Photography.



BioCool™ Controlled Rate Freezer

The Asymptote EF600, a unique liquid nitrogen free, controlled-rate freezer, is electrically powered by a Stirling Cycle Cryocooler rather than liquid nitrogen. This allows the freezer to be used where liquid nitrogen is in short supply, where extra high air quality is needed, or where there is a risk of LN2 contamination to samples.



Asymptote liquid nitrogen free controlled-rate freezer

The Planer Kryo 360 cell freezer controls down to a  $-180^{\circ}\text{C}$  end temperature to ensure sample integrity during transfer to storage. Fully programmable, it allows the use of protocols associated with the most advanced cryopreservation techniques and is widely used in laboratories around the world.



Planer Kryo 360 programmable cell freezer

The Crysalyz controlled rate freezer: programmes, time and temperatures may be entered via a touch screen with up to 100,000 cycles held on the onboard SD card; the data can be retrieved by any PC or Mac computer. A battery back up operates the system for 3 hours; its portability and 3.2 kg weight make it especially suited to veterinary purposes.

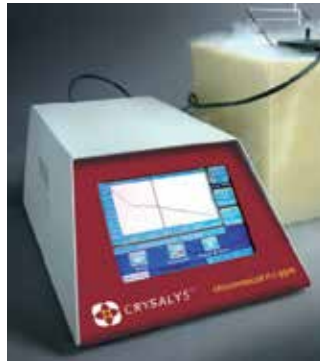

Crysalys controlled rate freezer

The Gemini Tinytag View 2 data logger, when used with a specially designed probe, is used for temperature monitoring in cryogenic environments down to  $-200\text{ }^{\circ}\text{C}$ .



Tinytag View 2 data logger

The CoolCell is an alcohol-free cell freezing container which provides a reproducible cooling rate of  $1\text{ }^{\circ}\text{C}/\text{minute}$  when placed in a  $-80\text{ }^{\circ}\text{C}$  freezer. No alcohol is required to control the freeze rate as the design and materials of the CoolCell ensure precise and uniform heat removal from cryovials.



CoolCell®, an alcohol-free cell freezing container



The Planer ShipsLog is a datalogger specifically designed for vapour shippers, which maintains a downloadable temperature history of samples during transit.

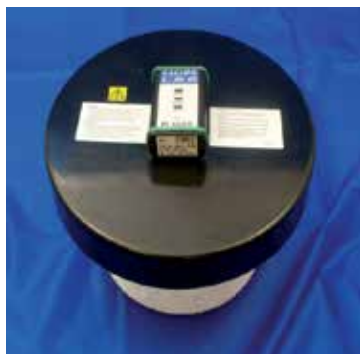

ShipsLog datalogger for vapour shippers

The Liquidus Tracker is a new controlled vitrifier for cryopreservation of samples using the liquidus tracking technique. This approach may have uses in vitrifying larger samples and those which are currently difficult to cryopreserve.



Liquidus Tracker controlled vitrifier for cryopreservation

#### 4. Acknowledgement

We would like to thank Dr. Damian Marshall, Principal Scientist, LGC Ltd, Teddington, UK and Mr Ian Pope, Coreus Consulting, Faribault, MN, USA, for their valuable assistance with this chapter.

Additional material can be found in 'Cryopreservation and Freeze-Drying Protocols'; Day, J.; Stacey, G. (Eds.); 2nd ed., 2007 Humana Press Cryopreservation of Animal and Human Cell Lines; See

Chapter 3; Pegg, D.E. Principles of Cryopreservation.

Chapter 16; Morris, C; Cryopreservation of Hematopoietic Stem/Progenitor Cells;

Chapter 17; Watt S., Austin E., Armitage S.,

## 5. References

- Byers, K. (1999) Risks associated with liquid nitrogen cryogenic storage systems. *Journal of the American Biological Safety Association*, Vol 4, No 3. pp. 143-146.
- Glenister, P., Whittingham, Lyon, M. (1984) Further studies on the effect of radiation during the storage of frozen 8-cell mouse embryos at -196 °C. *Journal Reproductive Fertility*, Vol 70, No. 1, (Jan 1984), pp. 229-34
- Lovelock J E (1953) The haemolysis of human red blood cells by freezing and thawing *Biochim Biophys Acta* 10, 414-426
- Pegg, D., Wusteman, M. & Wang, L. (2006a) Cryopreservation of articular cartilage. Part 1: Conventional cryopreservation methods. *Cryobiology*, Vol 52, No. 3, (June 2006), pp. 335-346
- Pegg, D., Wang, L., Vaughan, D., (2006b) Cryopreservation of articular cartilage 3: Vitrification methods. *Cryobiology*, Vol 52, No. 3, (June 2006), pp.360-368
- Pegg D.E., Wusteman C. and Boylan S. (1997) Fractures in cryopreserved elastic arteries. *Cryobiology*, 34, 183-192.
- Polge C, Smith A U, and Parkes A S. (1949) Revival of spermatozoa after vitrification and dehydration at low temperatures *Nature*, 164, 666.
- Wang L, Pegg D.E., Lorrison J., Vaughan D. and Rooney P. Further work on the cryopreservation of articular cartilage with particular reference to the liquidus-tracking method *Cryobiology*. 55, 138-147 (2007).
- Saragusty, J., Arav, A. (2011) Current progress in oocyte and embryo cryopreservation by slow freezing and vitrification. *Reproduction*, Vol 141, (Jan 2011), pp. 1-19
- Stachecki, J., Cohen, J. (2008) S3 Vitrification system: a novel approach to blastocyst freezing. *The journal of clinical embryology*, Vol 11. No. 4, (2008), pp. 5-14
- Su, S., Garbers, S., Reiper, T. (1996) Temperature variations in upright mechanical freezers. *Cancer, epidemiology, biomarkers and prevention*, Vol 5, (1996), pp. 139-40
- Sutton R.L. (1991) Critical cooling rates to avoid ice crystallization in solutions of cryoprotective agents. *J. Chem. Soc. Faraday Trans.*, 87(1), 101-105.
- Wang L, Pegg D.E., Lorrison J., Vaughan D. and Rooney P. Further work on the cryopreservation of articular cartilage with particular reference to the liquidus-tracking method *Cryobiology*. 55, 138-147 (2007).

# Technologies for Cryopreservation: Overview and Innovation

Edoardo Lopez, Katuscia Cipri and Vincenzo Naso  
*“Sapienza” University of Rome, Rome  
Italy*

## 1. Introduction

The proposed chapter investigates methods, devices and technologies for cryopreservation, explaining the most used cooling processes, as well as conventional and innovative technologies adopted. Main processes used for cryopreservation of oocytes, embryos and sperms can be reassumed in three categories:

1. slow freezing
2. vitrification
3. ultra-rapid freezing

Research is not intended to be exhaustive, but is aimed at covering most of relevant topics.

Slow freezing involves step-wise programmed decrease in temperature. The procedure is lengthy and requires the use of expensive instrumentation. The process does not exclude ice crystal formation, which can have extremely deleterious effects (Pegg, 2005).

In the vitrification process, the use of CryoProtectant Agents and the increasing of cooling rate (from 2,500 °/min to 130,000 °/min) avoid the ice crystal formation, increasing the embryos and oocytes survival. Unfortunately, common cryoprotectants are toxic and the immersion of solution directly in liquid nitrogen can be cause of contamination of embryos and oocytes with bacterium, mushroom and virus.

Ultra-rapid freezing can be considered a midway technique between slow freezing and vitrification, but its application has demonstrated lower performances than the other two processes.

## 2. Slow freezing

Necessary condition for slow freezing is freezing cells with a cooling rate equal or lower than 1°/min, before storing them at -130° or lower (De Santis & Coticchio, 2011). If cell is cooled down very slowly, it will be exposed to growing concentrations of cellular solutes due to ice formation inside the solution, with a PH variation and cellular dehydration. If it is cooled down too fast, crystal nucleuses will form in the solution and inside the cell, with the destruction of cell membrane. Usually at temperature below -60°, the samples can be immersed directly in liquid nitrogen or transferred to freezer of maintenance without further loss of viability. Slow freezing generally lasts one or two hours. However, a greater amount of cells can be frozen at a time (Ha et al., 2005), and lower quantity of CPA are used than in vitrification.

## 2.1 Programmable freezers

Currently, programmable freezers are the most common technology for slow freezing process. Programmable freezers are based on liquid nitrogen technology, but their use is denied in areas without availability of nitrogen or during long transport. Cooling rate is controlled by a heater (Asymptote EF600, Cryologic CL8800) or by the synchronous use of two valves.

Main characteristics of the most common programmable freezers are shown in Tab. 1. <sup>1</sup>

	Kryo 360	Kryo 560M	Cryo-Logic 8800 + Fast CryoChamber	Thermo Scientific Forma 94741
Producer	Planer plc	Planer plc	CryoLogic	Fisher Scientific
Control range [°]	+40 to -180	+30 to -180	+40 to -120	+50 to -180
Cooling rates [°/min]	-0.01 to -50	-0.01 to -50	-0.04 to -10 (at -40qC)	-0.1 to -50
Heating rates [°/min]	0.01 to 10	0.01 to 10	—	0.1 to 10
Capacity [l]	1.7 or 3.3	16	11.5	17 or 48

Table 1. Programmable freezers main characteristics

## 2.2 Stirling engine cryocooler

The **Asymptote EF600** is the first commercially available programmable freezer which does not require liquid-nitrogen. The absence of liquid-nitrogen reduces drastically risk of contamination, and allows to freeze cells where nitrogen is not available (i.e. during transport or in other borderline applications).



Fig. 1. Asymptote EF600 (<http://www.asymptote.co.uk/>)

<sup>1</sup> Research is not intended to be exhaustive

The Asymptote EF600's cooling source is a Stirling Engine, a closed cycle machine in which the refrigerant working fluid is contained inside the machine, and only a source of mechanical or electrical energy is required<sup>2</sup> in order to reach temperature below  $-100^{\circ}$ .

Studies on human spermatozoa (linear cooling at  $-2^{\circ}/\text{min}$  until nucleation followed by linear cooling at  $-10^{\circ}/\text{min}$  to  $-100^{\circ}$ ), embryonic stem cells (linear cooling at  $-2^{\circ}/\text{min}$  until nucleation followed by linear cooling at  $-1^{\circ}/\text{min}$  to  $-45^{\circ}$ ) mouse embryos (linear cooling at  $-2^{\circ}/\text{min}$  until nucleation followed by linear cooling at  $-0.3^{\circ}/\text{min}$  to  $-35^{\circ}$  and at  $-10^{\circ}/\text{min}$  to  $-100^{\circ}$ ) and horse semen (linear cooling at  $-2^{\circ}/\text{min}$  until nucleation followed by linear cooling at  $-4^{\circ}/\text{min}$  to  $-80^{\circ}$ ) were carried on, considering survival rate as a parameter for assessing the performances of the proposed system (Faszer et al., 2006; Morris et al., 2006).

Results show that Stirling Engine cryocooler can establish the desired time-temperature profile inside the test tubes and the viability after thawing data confirm that the system can be used for slow freezing applications.

However, Stirling Engines are affected by vibrations, as stated by (Hughes et al., 2000) and (Suárez et al., 2003). Vibrations might damage cells; furthermore, manual nucleation cannot be performed at a desired temperature, since vibrations generally start the nucleation process (as reported by (De Santis et al., 2007; Edgar, 2009; Rosendahl et al., 2011)).

### 2.3 Pulse tube cryocooler

In order to overcome the problems connected with vibrations of Stirling Engines, a programmable freezer based on a Pulse Tube cryocooler is being developed in "Sapienza" University of Rome Laboratory of Mechanical Engineering, in collaboration with *MES - Microconsulting Energia & Software S.c.a.r.l.*<sup>3</sup> and *LABOR S.r.l.*<sup>4</sup>. Alike the Stirling Engine, the Pulse Tube machine is a closed cycle system and it does not require liquid-nitrogen. The Pulse Tube cryocooler is able to reach temperatures below  $-150^{\circ}$  making the refrigerant fluid (that is generally helium or nitrogen) move oscillatory. The fluid motion is obtained using a compressor and a rotative valve. The Pulse Tube offers low vibrations, as discussed by (Ikushima et al., 2008; Riabzev et al., 2009; Suzuki et al., 2006; Wang & Hartnett, 2010).

Next to the *cold head* (the cooling part of the Pulse Tube), the refrigerant fluid absorbs heat from the test tube, cooling it. The Pulse Tube cryocooler is characterized by a higher cooling rate than the ideal one for cell freezing ( $0.1^{\circ}/\text{min} \div 10^{\circ}/\text{min}$ ) in the temperature range used for cryopreservation ( $+30^{\circ} \div -60^{\circ}$ ). The cooling rate is reduced in the proposed solution through a control system that can supply heat to the cryorefrigerator.

A heater is placed by the test tube holder (Fig. 2). The power dissipated through the heater for Joule effect varies according to two different control systems proposed:

1. **On-Off regulation.** A threshold control system has been implemented: the heater is activated when the real temperature is more than  $1^{\circ}$  below the desired temperature, and it is turned off when the real temperature is more than  $1^{\circ}$  over the desired temperature. Using this control system, oscillations of  $\pm 6^{\circ}$  around the desired temperature were obtained, as it is illustrated in Fig. 3 and Fig. 4.

<sup>2</sup> The Asymptote EF600 can be connected to a conventional 240V electricity supply or to a car battery

<sup>3</sup> Via A. Panzini, 3 - 00137 Roma, Italy

<sup>4</sup> Tecnapolo Tiburtino, Via G. Peroni 386 - 00131 Roma, Italy

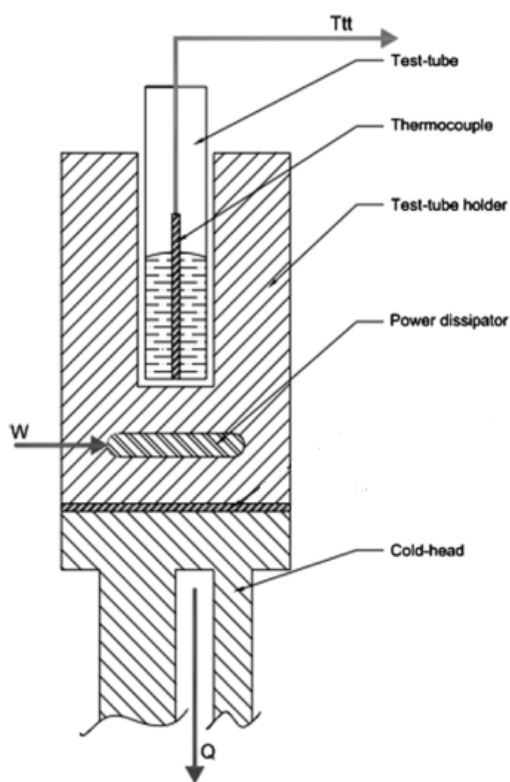

Fig. 2. Representation of the experimental apparatus.  $T_{tt}$  represents the temperature inside the test tube, measured by a thermocouple,  $Q$  is the heat absorbed by the refrigerating fluid and  $W$  is the dissipated power.

However, the oscillation might be reduced optimizing the threshold parameters. The *On-Off* regulation can be easily implemented, and it does not require the regulation of the power dissipated through Joule effect.

2. **Predictive model regulation:** the cooling slow-down is achieved by providing an amount of heat, variable with the time, that will be able to raise the temperature of the PT cold head to the desired value (Cipri et al., 2010). The amount of heat is calculated using a predictive and adaptive model. Using this regulation modality, oscillation can be removed. However, it requires the regulation of the power dissipated through Joule effects, increasing the cost of the hardware. Moreover, more computational power is required in order to calculate the amount of heat which has to be dissipated.<sup>5</sup>

Results are shown in Fig. 5 and Fig. 6.

In the determination of the *Predictive model* a lot of simplifying assumptions were made (Cipri et al., 2010), and we believed that the system should have better results if the model was set in more accurate way. Further researches are fostering investigation at Sapienza Laboratory.

At this very moment, the system is not yet commercially viable.

<sup>5</sup> An *On-Off* regulation is still used before the transition phase, marked by the abrupt rise of temperature typical of the subcooling

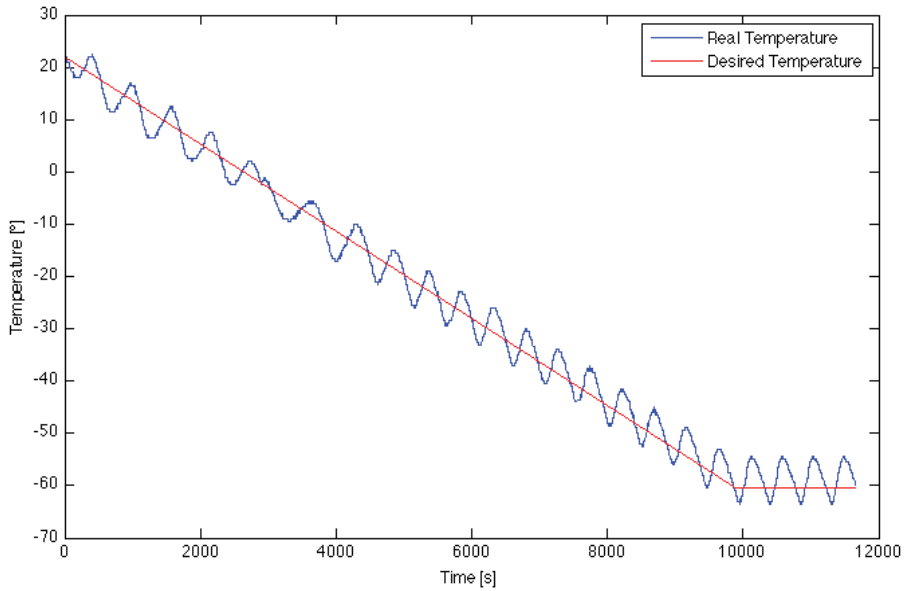

Fig. 3. *On-Off* regulation - Temperature inside the test tube vs time. A desired cooling rate of  $-0.5^{\circ}/\text{min}$  was selected.

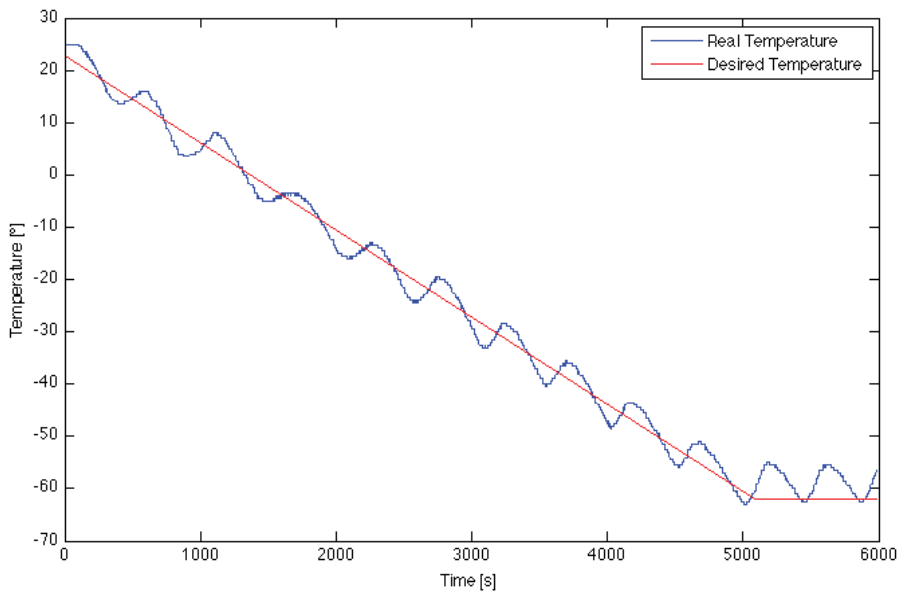

Fig. 4. *On-Off* regulation - Temperature inside the test tube vs time. A desired cooling rate of  $-1^{\circ}/\text{min}$  was selected.

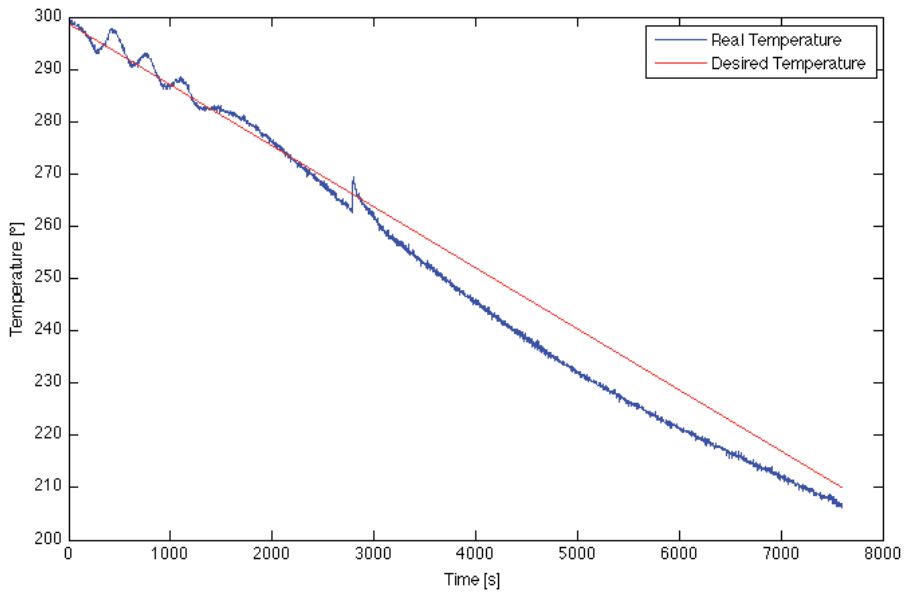

Fig. 5. *Predictive model* regulation - Temperature inside the test tube vs time. A desired cooling rate of  $-0.7^{\circ}/\text{min}$  was selected.

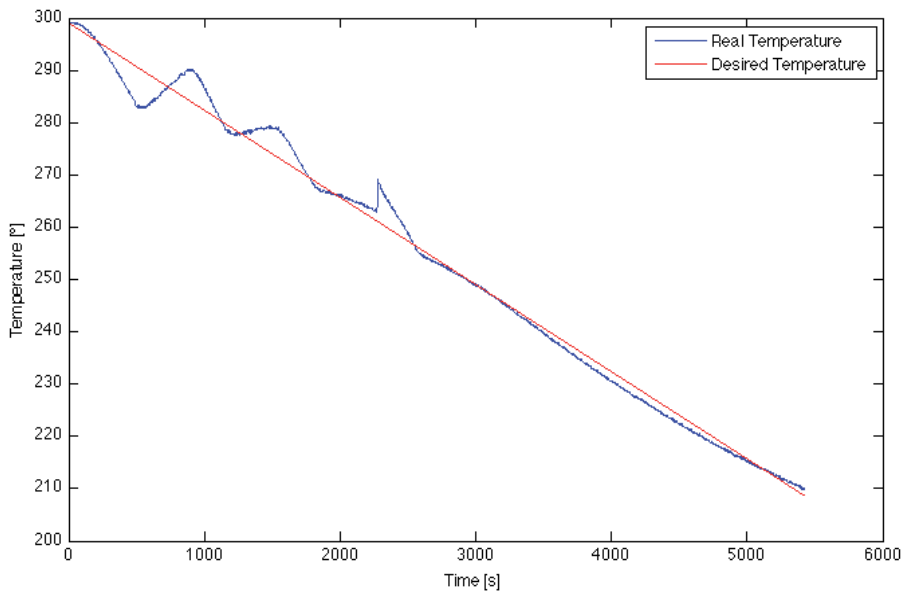

Fig. 6. *Predictive model* regulation - Temperature inside the test tube vs time. A desired cooling rate of  $-1^{\circ}/\text{min}$  was selected.



### 3. Vitrification

A criticality of common cryopreservation methods consists in the formation of ice crystals that drastically reduces the survival of treated embryos and oocytes. Vitrification process produces a glasslike solidification of living cells which completely avoids ice crystal formation. The process is based on the principle that water, characterized by high cellular viscosity increased by the adding of CryoProtectant Agent (CPA), and frozen using a high cooling rate, is not capable of forming ice. The main limits of Vitrification process are represented by: use of potentially toxic cryoprotectant; risk of contamination of embryos and oocytes with bacterium, mushroom and virus when directly immersed in liquid nitrogen or during the storage phase. Studies have demonstrated that reduced quantity of CPA can be used if the cooling rate is increased.

A freezing rate of  $2,500^{\circ}/\text{min}$  and CPA concentration of 5-7 M is reached with the immersion of embryos and oocytes in micro-capillary straws, while in the pulled straws the cooling rate is about  $20,000^{\circ}/\text{min}$  (Kuleshova & Lopata, 2002). Theoretically, the reaching of a cooling rate of  $10^7^{\circ}/\text{sec}$  should allow to vitrify also in pure water, but this rating is not practicable at the moment. Several studies are also oriented to formulate nontoxic and more efficient Vitrification solutions, also combining different cryoprotectants such as sugars and polymers or establishing modern solutions that include non-penetrating additives.

Moreover, the implementation of *Minimum Volume methods* has allowed to reduce the concentration of cryoprotectant. EG (ethylene glycol), characterized by low toxicity, is an important component of vitrification solution, commonly combined with DMSO or PROH (propanediol). In particular, non-permeable cryoprotectants (such sucrose or PVP) can be added in the solution on order to reduce the concentration of permeable cryoprotectants and facilitate dehydration and vitrification. Researches oriented to improve the characteristics of cryoprotectants have been carrying on in order to reduce toxicity. An EG and sucrose (non-permeable cryoprotectants) solution has been tested for cryopreservation of all preimplantation stages of *in vivo* generated mouse and day-6 sheep embryos. Experiments have not shown a loss of viability *in vitro* or *in vivo*. The same solution has been proved for vitrification of human oocytes, attaining high surviveal rates using conventional straws.

Another solution used to reduce toxicity is to equilibrate the cryoprotectant using a two-step method: the pretreatment solution, named *equilibration solution*, contains 20-50% concentrations of permeating cryoprotectants. The lower concentration of permeating cryoprotectants in the equilibration solution is much less toxic than the vitrification solution. The permeating cryoprotectant enters into the cells and facilitytes the intracellular vitrification. The cells pretreatment with equilibration solution is used in oocytes vitrification: this method has been demonstrated to increase the survival rate after thawing.

Main devices, commonly use in vitrification, are *Open Supports: Pulled Straws, CryoLoop, CryoEM, Cryoleaf* and *CryoTop*. The risk of contamination, due to the use of *Open Supports* for vitrification, limits the use of this process for human cells and tissues, according to the European regulations. In order to reduce contamination risks, *Close Supports* have been introduced: unfortunately their use decreases the cooling rate with consequently need to improve the quantity of CPA for guaranteeing the same survival rate. Vitrification process has demonstrated high performance in term of survival after thawing, comparable to slow cooling and it has become a promising alternative in cryopreservation of mammalian embryos and especially oocytes, through application of slow-rate freezing process.

### 3.1 Open supports

#### 3.1.1 Open Pulled Straw (OPS)

Open Pulled Straw (OPS) have been designed to guarantee a ultra rapid freezing without ice crystals formation. The system, ideated by G. Vajta in 1998, is based on the hypothesis that decreasing the standard straw diameter, the volume of solution to vitrify is reduced too, raising the cooling rate. This method is so characterized by a very high cooling and warming rates (over 20,000° /min) and a short contact with concentrated cryoprotective additives (less than 30 sec over -180°). This approach reduces the possibility of chilling injury and toxic and osmotic damage. Several OPS have been developed reducing the diameter of standard straws of a half, increasing the cooling rate by 10 times and reducing by 30% the concentration of CPA and the time of exposition. Common OPS are standard 0.25 mL straws with one extremity pulled and thinned by heating. This solution increases the superficies/volume rate and hastens the cooling rate of the 2  $\mu$ L drop set to contain the embryo. The Open Pulled Straw produced by *MTG* are made of PVC: with a length of 93 mm, straws can have an inner tip diameter approximately of 0.65 mm for Standard OPS and of 0.3 mm for super fine OPS. Before plunging the thin straw into liquid nitrogen, embryos are treated with highly concentrated cryoprotectant (CPA) solutions of ethylene glycol (EG) and dimethyl-sulfoxide (DMSO), in variable percentage.

#### 3.1.2 Cryoloop

Cryoloop is generally applied to investigate the contribution given by cortical areas to network interactions and cerebral functions.

The Cryoloop is manufactured from straight 23 gauge hypodermic stainless steel tubing, having external and internal diameters respectively of 0.635 mm and 0.33 mm. Methanol, drawn from a external reservoir, is pumped in a Teflon tube directly in the Cryoloop that is in contact with the brain. Before reaching the Cryoloop, tubes containing Methanol are coiled and immersed in a bath of methanol and dry-ice pellets. The mixture cools the flowing methanol at a temperature of -75°. A microthemocouple, connected to a digital thermometer allows to monitor the temperature of the Cryoloop.

The use of Cryoloop device in human oocytes vitrification is under investigation. Experiments are now focused on animal oocytes and blastocytes cryopreservation. Cryoloops used for vitrification consist of a nylon loop of 10 or 20 micron diameters mounted on a stainless steel pipe inserted into the lid of a cryovial (Fig. 7). One of the main producers is the Hampton Research Corporation.

For vitrification, blastocytes are placed on a cryoloop that has been coated with a thin film of cryoprotectant solution. Blastocytes on the cryoloop are placed into the cryovial, which is submerged and filled with liquid nitrogen and the vial is sealed. Studies demonstrate that both mouse and human blastocystes can be successfully vitrified by suspension on a nylon loop and immersing directly into nitrogen. Mouse oocytes cryopreservation has provided successful results, but this method has not been applied to human oocytes. Tests on rabbit oocytes showed a good survival rate approximately of 80% for four different protocols.

#### 3.1.3 Cryo-electron microscopic (CryoEM)

The Cryo-electron microscopic technique involves freezing biological samples in order to view the samples with the lowest distortion and the fewest possible artifacts.

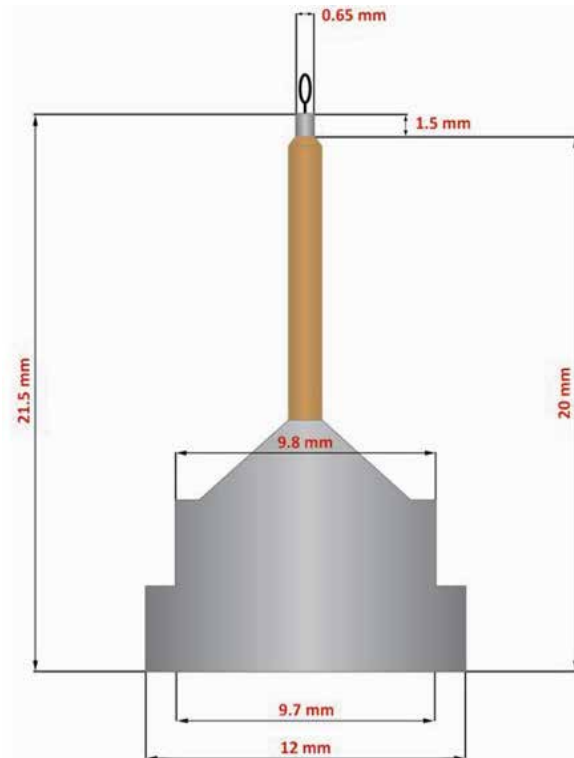

Fig. 7. CryoLoop Properly Installed in a CrystalCap Copper Magnetic - *Hampton Research Corporation*

Biological material is spread on an electron microscopy grid and is preserved in a frozen-hydrated state by rapid freezing (about  $3,000^{\circ}/\text{min}$ ), usually in ethane slush close to liquid nitrogen temperature. Specimens, maintained at liquid nitrogen temperature or colder, are contained into the high-vacuum of the electron microscope column. The frozen sample grid is then kept at liquid nitrogen temperature in the electron microscope and digital micrographs are collected with a camera. Images obtained from the cryo-electron microscopy are usually very noisy and have very low contrast. It is necessary to smooth the noise as well as enhance the contrast.

### 3.1.4 Cryoleaf

Cryoleaf is an open device for embryos and oocytes vitrification and storage (Fig. 8). Developed by Dr. Chian and Prof. Tan at McGill University, Montreal, the system uses PROH, EG and sucrose as cryo-protectants in the cooling phase, while in the warming procedure media contains sucrose. The recommended maximum load of the McGill Cryoleaf is 2-3 oocytes or embryos.

Oocytes or embryos are prepared for vitrification according to laboratory protocols. The outer cover of the McGill Cryoleaf is plunged into the liquid nitrogen bath, allowing the air to come out. Vitrified oocytes or embryos are quickly loaded into the McGill Cryoleaf using a suitable pipette. The excess of media, that must be less than  $1 \mu\text{l}$ , has to be removed. The McGill



Fig. 8. McGill Cryoleaf Open System for Vitrification

Cryoleaf is inserted, with oocytes or embryos, directly into liquid nitrogen. Then, the Cryoleaf is blocked, sliding the protective sleeve over the tip.

### 3.1.5 Cryotop

Cryotop method, developed by Kuwayama in the Advanced Medical Research Institute of Kato Ladies Clinic, is based on the assumption that minimizing the volume<sup>6</sup> of the vitrification solution, increases both cooling and warming rates, also decreasing the chance of ice crystal nucleation/formation. Moreover the high-rate cooling decreases CPA concentration, also reducing chilling injury occurring between +15° (in human GV oocytes even +25°) and -5°, which can be minimized by passing embryos or oocytes rapidly through this temperature zone. Finally, studies have demonstrated that the use of small devices eliminates embryo fracture damages, especially in open systems.

The Cryotop tool consists of a narrow, thin film strip (0.4 mm wide, 20 mm long 0.1 mm thick) attached to a hard plastic handle for a minimum volume cooling. To protect oocytes and embryo on strip from mechanical damage and virus contamination during storage, a 3 cm long plastic tube cap is attached to cover the film part (Fig. 9).

The tool and the solutions for Vitrification and warming are market by Kitazato Co., Fujinomiya, Japan.

After a two-step equilibration in a vitrification solution containing EG, DMSO and sucrose, oocytes and embryo are loaded with a narrow glass capillary onto the top of the film strip in a volume of <0.1 ml. After loading, almost all the solution is removed so as to leave only a thin layer covering the oocytes or embryos, and the sample is quickly immersed into liquid nitrogen. Subsequently, the plastic cap is pulled over the film part of the Cryotop, and the sample is stored under liquid nitrogen (Kuwayama, 2007).

The minimal volume increases the cooling and warming rates up to 40,000° /min, contributing positively to the embryos or oocytes survival.

Cryotop vitrification method is applied successfully in various areas of animal technology and now it is indicated as the process which guarantees the highest number of babies born

<sup>6</sup> According to common use, for Minimum Volume is intended less than 1 ml for direct dropping of samples into liquid nitrogen or the open pulled straw (OPS) method.



Fig. 9. Kitazato Cryotop - Kitazato Industries

after vitrification of human embryos and after cryopreservation of human oocytes worldwide. Clinical results are shown in Tab. 2

Reference	Cell	n	% Survival	% Pregnancy
Teramoto 2004	Blastocysts	197	100	57.7
Kuwayama 2005	Oocytes	64	91	41.3
Kuwayama 2005	PN Embryos D14	5881	100	-
Kuwayama 2005	Embryos D3	897	98	27
Kuwayama 2005	Blastocysts	6328	90	53
Lucena 2006	Oocytes	159	97	56.5
Antinori 2007	Oocytes	330	91	32.5
Cobo 2008	Oocytes	243	97	65.2
Cobo 2008	Oocytes	797	96	63.2

Table 2. Results achieved with Cryotop vitrification in human

### 3.1.6 Direct Cover Vitrification - DCV

The Direct Cover Vitrification - DCV is a new cooling method based on the minimum use of concentrated cryoprotectants and direct application of liquid nitrogen to the ovarian tissue. This way, the toxicity derived by cryoprotectants is reduced and the ice crystal injury is prevented. The ovary is immersed in a vitrification solution (0.8 ml) consisting of 15% EG, 15% DMSO and 0.5 M sucrose for 2 min.

The ovary is put in a 1.8-ml plastic standard cryovial, placed on a piece of gauze to remove the surrounding vitrification medium. Liquid nitrogen is directly applied onto the ovary for vitrification. The cap of the cryovial is closed. The lid does not have a hole. The vial is then placed into a liquid nitrogen tank.

DCV cryopreservation method, explored on mouse ovarian, has demonstrated to be highly efficient at increasing morphologically normal and viable follicles from cryopreserved ovarian tissue, compared with slow freezing and conventional vitrification.

### 3.1.7 Solid Surface Vitrification - SSV

The Solid Surface Vitrification - SSV has been developed at the Department of Animal Science, University of Connecticut. The method aims at defining an effective protocol to cryopreserve

bovine oocytes for research and practice of parthenogenetic activation, in vitro fertilization and nuclear transfer.

Bovine oocytes matured in vitro are transferred to a vitrification solution (35% EG, 5% polyvinyl-pyrrolidone, 0.4 M trehalose in TCM 199 and 20% FBS). A metal cube covered with aluminum foil is partially submersed into liquid nitrogen (Fig. 10): the surface reaches the temperature of  $-150^{\circ}$ . Microdrops of vitrification solution, containing the oocytes, are dropped onto the cold upper surface of the metal cube and are instantaneously vitrified. The vitrified microdrops are then stored in liquid nitrogen (Dinnyés et al., 2000).

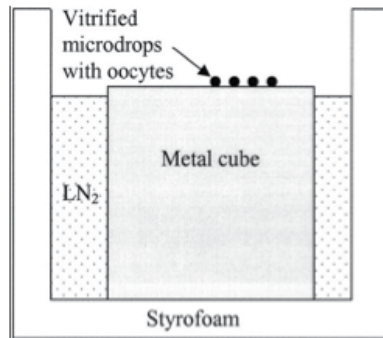

Fig. 10. The solid surface vitrification (SSV) device

### 3.2 Closed supports

#### 3.2.1 Cryotip

Cryotip consists of a plastic straw with a thin part (250  $\mu\text{m}$  inner diameter, 20  $\mu\text{m}$  wall thickness and 3 cm length) connected to a thick part (2000  $\mu\text{m}$  inner diameter and 150  $\mu\text{m}$  wall thickness, 4.5 cm length) and equipped with a movable protective metal sleeve (Fig. 11) (Kuwayama, Vajta, Ieda & Kato, 2005).



Fig. 11. The Cryotip is a finely pulled straw designed for holding gametes or embryos

Embryos are loaded in approximately 1  $\mu\text{l}$  solution into the narrow part of the CryoTips without any air bubbles by aspiration of medium. Subsequently, the straw is heat-sealed at both ends, the protective sleeve is pulled over the narrow part and the device is plunged into liquid nitrogen. The time required for loading, sealing, adjustment of the sleeve and plunging does not exceed 90 s. The use of the closed Cryotip system eliminates potential embryo's contamination during cryopreservation and storage without compromising survival and developmental rates in vitro and in vivo (Kuwayama, Vajta, Ieda & Kato, 2005).

### 3.2.2 Isachenko Method

In the *Isachenko Method* (Isachenko et al., 2005), embryos are located inside a open-pulled straws (OPS). The OPS is placed inside a sterile insemination straw (indicative size 90-mm), manufactured from standard 0.5-mL insemination straws. One end of sterile insemination straw is previously sealed using a hand-held sealer. The open end is hermetically closed by a metal ball and this container (OPS and sterile insemination straw) is plunged into liquid nitrogen ("straw in straw" vitrification). The *Isachenko Method*, applied to biopsied mouse pronuclear embryos is resulted efficient as conventional vitrification, guaranteeing a complete isolation of embryos from liquid nitrogen and avoiding potential contamination by pathogenic microorganisms.

### 3.3 Innovative vitrification devices

A new solution to increase the cooling rate reducing the use of cryoprotectants consists in the physical reduction of liquid nitrogen temperature, as happens in the **Vit-Master**, a new device developed at IMT, Israel. In order to avoid the vaporization of N<sub>2</sub>, the temperature of liquid nitrogen is reduced until -210° (boiling point of nitrogen), applying a negative pressure (Arav et al., 2002). The evaporative cooling causes the nitrogen to partially solidify, thus creating a nitrogen slush. Samples immersed in nitrogen slush cool more rapidly because they come into contact with liquid nitrogen sooner than those immersed in normal liquid nitrogen (Cai et al., 2005). The *Vit Master* vitrification machine can provide a very high cooling rate (up to 135,000°/min). The cooling rate is especially enhanced in the first stage of cooling (from 20 to -10°), when it is six, four or two times higher with 0.25-ml straws, open pulled straws (OPS) or electron-microscope (EM) grids, respectively. Between -10 and -150°, the cooling rate is only about doubled by use of the *Vit Master*, but that was found to be enough to reduce the chances of devitrification and recrystallization during warming.

Research about using a **Pulse Tube** for Vitrification is ongoing at "Sapienza" - University of Rome.

## 4. Ultra-rapid freezing

Ultra-rapid freezing can be considered a midway technique between slow freezing and Vitrification. It is quicker than the slow-freezing technique, does not involve the use of programmable machines and requires lower concentrations of cryoprotectant agents (CPA) than those used in vitrification.

Experimental results demonstrate that this technique has lower performances than slow freezing's and vitrification's ones (AbdelHafez et al., 2010).

## 5. Comparison between vitrification and slow freezing

Vitrification is an attractive freezing technique: supports required are cost effective and experimental data show an high survival rate after thawing. For example, a survival rate of 99% was quoted in (KITAZATO BioPharma Co., Ltd. - <http://www.kitazato-biopharma.com/>, n.d.) using a *Cryotop* support.

However, vitrification exposes cells to a high risk of contamination, since cells are generally plunged directly into liquid-nitrogen. Risk of contamination is reported in (Bielanski et al., 2000), where cells frozen using vitrification were exposed to the bovine immunodeficiency

virus (BIV), that can be considered a model for retrovirus like the human immunodeficiency virus (HIV). Risk of Hepatitis B contamination is analyzed in (Tedder et al., 1995).

Moreover, vitrification requires a greater amount of CPA (CryoProtectant Agent) than Slow Freezing does, increasing the toxicity of the environment.

In order to reduce the risk of contamination, *closed supports* for vitrification were developed (*Cryotip* and *Isachenko Method*). However, a lower survival rate is obtained than using an *open support*.

A lower survival rate after thawing using Slow Freezing instead of Vitrification was claimed by many authors. (Fadini et al., 2009) reports a survival rate of human oocytes of 78.9% using Vitrification, while it is reduced to 57.9 % using Slow Freezing (*p-value* lower than 0.0001); similar results are shown in (Vutyavanich et al., 2010) (where survival rate of human spermatozoa is measured equal to 64.8% using Vitrification and equal to 50.4% using Slow Freezing, *p-value* equal to 0.0036). However, many authors believe that a better understanding of slow freezing principles will improve its performances (Bianchi et al., 2007; De Santis et al., 2007; Edgar, 2009; Fadini et al., 2009; McGrath, 2009).

Both Vitrification and Programmable Freezers (the most common machines use for Slow Freezing) require a supply of liquid-nitrogen, that is a limiting factor in many situations of inefficient or absent nitrogen distribution network, such as small industries, isolated places and during transport of cells. In order to overcome to this limitation, two alternative systems for Slow Freezing (*Asymptote EF600* and *Pulse Tube Cryocooler*) have been developed.

Stirling Engine<sup>7</sup> and Pulse Tube Cryocooler are closed-cycle machines, reducing risk of contamination and toxicity. A cells freezing system based upon closed-cycle machines is a viable commercial solution, especially for those markets where liquid nitrogen supply is difficult or excessively expensive, or during transport.

However, Stirling Engine exhibits high vibration, thus the nucleation process can not be inducted manually. Moreover, vibrations might damage cells. Those problems are avoided using a Pulse Tube cryocooler.

The application of a Pulse Tube Cryocooler for cells cryopreservation is under developing at "Sapienza" - University of Rome Laboratory of Mechanical Engineering. A validation of the proposed system with the assessment of cells survival rate after thawing is envisaged as next step. Future work will also focus on the development of a cost effective control system which allows the operator to set a desired cooling rate.

## 6. Acknowledgment

We would really like to thank *MES - Microconsulting Energia & Software S.c.a.r.l.* and *LABOR S.r.l.* for their contribution to the realization of this work.

## 7. References

- AbdelHafez, F. F., Desai, N., Abou-Setta, A. M., Falcone, T. & Goldfarb, J. (2010). Slow freezing, vitrification and ultra-rapid freezing of human embryos: a systematic review and meta-analysis., *Reproductive biomedicine online* 20(2): 209–22.  
URL: <http://www.ncbi.nlm.nih.gov/pubmed/20113959>

<sup>7</sup> The Stirling Engine is used in the Asymptote EF600



- Angle, M. (2007). Survival and re-expansion of mouse blastocysts following vitrification in two fda-approved closed devices with and without assisted shrinkage, *Fertility and Sterility* 88(September): S90–S91.  
URL: [http://www.fertstert.org/article/S0015-0282\(07\)01955-3/abstract](http://www.fertstert.org/article/S0015-0282(07)01955-3/abstract)
- Arav, A., Yavi, S., Zeron, Y., Natan, D., Dekel, I. & Gacitua, H. (2002). New trends in gamete's cryopreservation, *Molecular and Cellular Endocrinology* 187(1-2): 77–81.  
URL: <http://linkinghub.elsevier.com/retrieve/pii/S0303720701007006>
- Asymptote Ltd - <http://www.asymptote.co.uk/> (n.d.).
- Bianchi, V., Coticchio, G., Distratis, V., Di Giusto, N., Flamigni, C. & Borini, a. (2007). Differential sucrose concentration during dehydration (0.2 mol/l) and rehydration (0.3 mol/l) increases the implantation rate of frozen human oocytes, *Reproductive BioMedicine Online* 14(1): 64–71.  
URL: <http://linkinghub.elsevier.com/retrieve/pii/S1472648310607651>
- Bielanski, A., Nadin-Davis, S., Sapp, T. & Lutze-Wallace, C. (2000). Viral contamination of embryos cryopreserved in liquid nitrogen., *Cryobiology* 40(2): 110–6.  
URL: <http://www.ncbi.nlm.nih.gov/pubmed/10788310>
- Blayney, M. (2005). *Cryopreservation of embryos and spermatozoa*, Taylor & Francis, chapter 17, p. 322.
- Cai, X. Y., Chen, G. a., Lian, Y., Zheng, X. Y. & Peng, H. M. (2005). Cryoloop vitrification of rabbit oocytes., *Human reproduction (Oxford, England)* 20(7): 1969–74.  
URL: <http://www.ncbi.nlm.nih.gov/pubmed/15932910>
- Canemco and Marivac - <http://www.canemco.com/> (n.d.).
- Chen, S.-U., Chien, C.-L., Wu, M.-Y., Chen, T.-H., Lai, S.-M., Lin, C.-W. & Yang, Y.-S. (2006). Novel direct cover vitrification for cryopreservation of ovarian tissues increases follicle viability and pregnancy capability in mice., *Human reproduction (Oxford, England)* 21(11): 2794–800.  
URL: <http://www.ncbi.nlm.nih.gov/pubmed/16982660>
- Chen, S. U., Lien, Y. R., Chen, H. F., Chao, K. H., Ho, H. N. & Yang, Y. S. (2000). Open pulled straws for vitrification of mature mouse oocytes preserve patterns of meiotic spindles and chromosomes better than conventional straws., *Human reproduction (Oxford, England)* 15(12): 2598–603.  
URL: <http://www.ncbi.nlm.nih.gov/pubmed/11098033>
- Chen, S. U., Lien, Y. R., Cheng, Y. Y., Chen, H. F., Ho, H. N. & Yang, Y. S. (2001). Vitrification of mouse oocytes using closed pulled straws (CPS) achieves a high survival and preserves good patterns of meiotic spindles, compared with conventional straws, open pulled straws (OPS) and grids., *Human reproduction (Oxford, England)* 16(11): 2350–6.  
URL: <http://www.ncbi.nlm.nih.gov/pubmed/11679519>
- Chen, S.-U. & Yang, Y.-S. (2009). Slow freezing or vitrification of oocytes: their effects on survival and meiotic spindles, and the time schedule for clinical practice., *Taiwanese journal of obstetrics & gynecology* 48(1): 15–22.  
URL: <http://www.ncbi.nlm.nih.gov/pubmed/19346187>
- Chian, R., Son, W., Huang, J., Cui, S., Buckett, W. & Tan, S. (2005). High survival rates and pregnancies of human oocytes following vitrification: preliminary report, *Fertility and Sterility* 84(September): S36–S36.  
URL: [http://www.fertstert.org/article/S0015-0282\(05\)01544-X/abstract](http://www.fertstert.org/article/S0015-0282(05)01544-X/abstract)
- Cipri, K., Lopez, E. & Naso, V. (2010). Investigation of the use of Pulse Tube in cell cryopreservation systems, *Cryobiology* 61(2): 225–30.  
URL: <http://www.ncbi.nlm.nih.gov/pubmed/20691677>
- CryoLogic - <http://www.cryologic.com/> (n.d.).

- De Santis, L., Cino, I., Rabbellotti, E., Papaleo, E., Calzi, F., Fusi, F., Brigante, C. & Ferrari, a. (2007). Oocyte cryopreservation: clinical outcome of slow-cooling protocols differing in sucrose concentration, *Reproductive BioMedicine Online* 14(1): 57–63.  
URL: <http://linkinghub.elsevier.com/retrieve/pii/S147264831060764X>
- De Santis, L. & Coticchio, G. (2011). Theoretical and experimental basis of slow freezing., *Reproductive BioMedicine Online* 22(2): 125–32.  
URL: <http://www.ncbi.nlm.nih.gov/pubmed/21237713>
- Dinnyés, a., Dai, Y., Jiang, S. & Yang, X. (2000). High developmental rates of vitrified bovine oocytes following parthenogenetic activation, in vitro fertilization, and somatic cell nuclear transfer., *Biology of reproduction* 63(2): 513–8.  
URL: <http://www.ncbi.nlm.nih.gov/pubmed/10906058>
- Edgar, D. (2009). Increasing dehydration of human cleavage-stage embryos prior to slow cooling significantly increases cryosurvival, *Reproductive BioMedicine Online* 19(4): 521–525.  
URL: <http://linkinghub.elsevier.com/retrieve/pii/S1472648309000169>
- Fadini, R., Brambillasca, F., Renzini, M. M., Merola, M., Comi, R., De Ponti, E. & Dal Canto, M. (2009). Human oocyte cryopreservation: comparison between slow and ultrarapid methods, *Reproductive BioMedicine Online* 19(2): 171–180.  
URL: <http://linkinghub.elsevier.com/retrieve/pii/S1472648310600697>
- Faszer, K., Draper, D., Green, J. E., Morris, G. J. & Grout, B. W. W. (2006). Cryopreservation of horse semen under laboratory and field conditions using a Stirling Cycle freezer., *Cryo letters* 27(3): 179–86.  
URL: <http://www.ncbi.nlm.nih.gov/pubmed/16892166>
- Fisher Scientific Italia - <http://www.it.fishersci.com/> (n.d.).  
Grant Instruments (Cambridge) Ltd - <http://www.grant.co.uk/> (n.d.).
- Grossman, G., Bradley, P. E., Lewis, M. a. & Radebaugh, R. (2011). Model for transient behavior of pulse tube cryocooler, *Cryogenics* 51(3): 124–131.  
URL: <http://linkinghub.elsevier.com/retrieve/pii/S0011227510002560>
- Ha, S. Y., Jee, B. C., Suh, C. S., Kim, H. S., Oh, S. K., Kim, S. H. & Moon, S. Y. (2005). Cryopreservation of human embryonic stem cells without the use of a programmable freezer., *Human reproduction* 20(7): 1779–85.  
URL: <http://www.ncbi.nlm.nih.gov/pubmed/15760949>
- Hampton Research - <http://hamptonresearch.com/> (n.d.).
- Hu, J., Dai, W., Luo, E., Wang, X. & Huang, Y. (2010). Development of high efficiency Stirling-type pulse tube cryocoolers, *Cryogenics* 50(9): 603–607.  
URL: <http://linkinghub.elsevier.com/retrieve/pii/S0011227510000548>
- Hughes, W., McNelis, M., Goodnight, T. & Center, N. G. R. (2000). Vibration Testing of an Operating Stirling Convertor, *Seventh International Congress on Sound and Vibration*, number November, National Aeronautics and Space Administration, Glenn Research Center.  
URL: <http://gltrs.grc.nasa.gov/reports/2000/TM-2000-210526.pdf>
- Ikushima, Y., Li, R., Tomaru, T., Sato, N., Suzuki, T., Haruyama, T., Shintomi, T. & Yamamoto, A. (2008). Ultra-low-vibration pulse-tube cryocooler system – cooling capacity and vibration, *Cryogenics* 48(9-10): 406–412.  
URL: <http://linkinghub.elsevier.com/retrieve/pii/S0011227508000490>
- Imura, J., Shinoki, S., Sato, T., Iwata, N., Yamamoto, H., Yasohama, K., Ohashi, Y., Nomachi, H., Okumura, N., Nagaya, S., Tamada, T. & Hirano, N. (2007). Development of high capacity Stirling type pulse tube cryocooler, *Physica C: Superconductivity* 463-465: 1369–1371.  
URL: <http://linkinghub.elsevier.com/retrieve/pii/S0921453407010404>

- Irvine Scientific - <http://www.irvinesci.com/> (n.d.).
- Isachenko, V., Montag, M., Isachenko, E. & van der Ven, H. (2005). Vitrification of mouse pronuclear embryos after polar body biopsy without direct contact with liquid nitrogen., *Fertility and sterility* 84(4): 1011–6.  
URL: <http://www.ncbi.nlm.nih.gov/pubmed/16213857>
- KITAZATO BioPharma Co., Ltd. - <http://www.kitazato-biopharma.com/> (n.d.).
- Koh, D. Y., Hong, Y. J., Park, S. J., Kim, H. B. & Lee, K. S. (2002). A study on the linear compressor characteristics of the Stirling cryocooler, *Cryogenics* 42(6-7): 427–432.  
URL: <http://linkinghub.elsevier.com/retrieve/pii/S0011227502000644>
- Kongtragool, B. & Wongwiset, S. (2003). A review of solar-powered Stirling engines and low temperature differential Stirling engines, *Renewable and Sustainable Energy Reviews* 7(2): 131–154.  
URL: <http://linkinghub.elsevier.com/retrieve/pii/S1364032102000539>
- Kongtragool, B. & Wongwiset, S. (2007). Performance of low-temperature differential Stirling engines, *Renewable Energy* 32(4): 547–566.  
URL: <http://linkinghub.elsevier.com/retrieve/pii/S0960148106000772>
- Kuleshova, L. L. & Lopata, A. (2002). Vitrification can be more favorable than slow cooling., *Fertility and sterility* 78(3): 449–54.  
URL: <http://www.ncbi.nlm.nih.gov/pubmed/12215314>
- Kuleshova, L. L. & Shaw, J. M. (2000). A strategy for rapid cooling of mouse embryos within a double straw to eliminate the risk of contamination during storage in liquid nitrogen., *Human reproduction (Oxford, England)* 15(12): 2604–9.  
URL: <http://www.ncbi.nlm.nih.gov/pubmed/11098034>
- Kuwayama, M. (2007). Highly efficient vitrification for cryopreservation of human oocytes and embryos: the Cryotop method., *Theriogenology* 67(1): 73–80.  
URL: <http://www.ncbi.nlm.nih.gov/pubmed/17055564>
- Kuwayama, M., Vajta, G., Ieda, S. & Kato, O. (2005). Comparison of open and closed methods for vitrification of human embryos and the elimination of potential contamination, *Reproductive BioMedicine Online* 11(5): 608–614.  
URL: <http://linkinghub.elsevier.com/retrieve/pii/S1472648310611698>
- Kuwayama, M., Vajta, G., Kato, O. & Leibo, S. P. (2005). Highly efficient vitrification method for cryopreservation of human oocytes, *Reproductive BioMedicine Online* 11(3): 300–308.  
URL: <http://linkinghub.elsevier.com/retrieve/pii/S1472648310608371>
- Lane, M., Schoolcraft, W. B. & Gardner, D. K. (1999). Vitrification of mouse and human blastocysts using a novel cryoloop container-less technique., *Fertility and sterility* 72(6): 1073–8.  
URL: <http://www.ncbi.nlm.nih.gov/pubmed/10593384>
- Liebermann, J. (2002). Potential Importance of Vitrification in Reproductive Medicine, *Biology of Reproduction* 67(6): 1671–1680.  
URL: <http://www.biolreprod.org/cgi/doi/10.1095/biolreprod.102.006833>
- Liebermann, J. & Tucker, M. J. (2002). Effect of carrier system on the yield of human oocytes and embryos as assessed by survival and developmental potential after vitrification., *Reproduction (Cambridge, England)* 124(4): 483–9.  
URL: <http://www.ncbi.nlm.nih.gov/pubmed/12361466>
- Lomber, S. G., Payne, B. R. & Horel, J. a. (1999). The cryoloop: an adaptable reversible cooling deactivation method for behavioral or electrophysiological assessment of neural function., *Journal of neuroscience methods* 86(2): 179–94.  
URL: <http://www.ncbi.nlm.nih.gov/pubmed/10065985>

- Lucena, E., Bernal, D. P., Lucena, C., Rojas, A., Moran, A. & Lucena, A. (2006). Successful ongoing pregnancies after vitrification of oocytes., *Fertility and sterility* 85(1): 108–11.  
URL: <http://www.ncbi.nlm.nih.gov/pubmed/16412739>
- Martino, a., Songsasen, N. & Leibo, S. P. (1996). Development into blastocysts of bovine oocytes cryopreserved by ultra-rapid cooling., *Biology of reproduction* 54(5): 1059–69.  
URL: <http://www.ncbi.nlm.nih.gov/pubmed/8722627>
- Matson, P., Kappelle, W. & Webb, S. (2008). Maximum rates of cooling by three programmable freezers, and the potential relevance to sperm cryopreservation., *Reproductive biology* 8(1): 69–73.  
URL: <http://www.ncbi.nlm.nih.gov/pubmed/18432308>
- Matsumoto, H., Jiang, J. Y., Tanaka, T., Sasada, H. & Sato, E. (2001). Vitrification of large quantities of immature bovine oocytes using nylon mesh., *Cryobiology* 42(2): 139–44.  
URL: <http://www.ncbi.nlm.nih.gov/pubmed/11448116>
- Mcgrath, J. (2009). *Predictive Models for the Development of Improved Cryopreservation Protocols for Human Oocytes*, number 7, Informa Helatcare, pp. 62–82.
- Morris, G., Acton, E., Faszler, K., Franklin, A., Yin, H., Bodine, R., Pareja, J., Zaninovic, N. & Gosden, R. (2006). Cryopreservation of murine embryos, human spermatozoa and embryonic stem cells using a liquid nitrogen-free, controlled rate freezer, *Reproductive BioMedicine Online* 13(3): 421–426.  
URL: <http://linkinghub.elsevier.com/retrieve/pii/S1472648310614484>
- Mukaida, T. (2003). Vitrification of human blastocysts using cryoloops: clinical outcome of 223 cycles, *Human Reproduction* 18(2): 384–391.  
URL: <http://www.humrep.oupjournals.org/cgi/doi/10.1093/humrep/deg047>
- Mukaida, T., Wada, S., Takahashi, K., Pedro, P. B., An, T. Z. & Kasai, M. (1998). Vitrification of human embryos based on the assessment of suitable conditions for 8-cell mouse embryos., *Human reproduction (Oxford, England)* 13(10): 2874–9.  
URL: <http://www.ncbi.nlm.nih.gov/pubmed/9804248>
- Nottola, S., Coticchio, G., Sciajno, R., Gambardella, a., Maione, M., Scaravelli, G., Bianchi, S., Macchiarelli, G. & Borini, a. (2009). Ultrastructural markers of quality in human mature oocytes vitrified using cryoleaf and cryoloop, *Reproductive BioMedicine Online* 19(October): 17–27.  
URL: <http://linkinghub.elsevier.com/retrieve/pii/S1472648310602805>
- Nowshari, M. a. & Brem, G. (2001). Effect of freezing rate and exposure time to cryoprotectant on the development of mouse pronuclear stage embryos., *Human reproduction (Oxford, England)* 16(11): 2368–73.  
URL: <http://www.ncbi.nlm.nih.gov/pubmed/11679522>
- Oberstein, N., O'Donovan, M. K., Bruemmer, J. E., Seidel, G. E. J., Camevale, E. M. & Squires, E. S. (2001). Cryopreservation of Equine Embryos by Open Pulled Straw, Cryoloop, or Conventional Slow Cooling Methods, *Theriogenology* 55: 607–613.  
URL: <http://www.ncbi.nlm.nih.gov/pubmed/21235366>
- Orief, Y., Schultze-mosgau, A., Dafopoulos, K. & Al-hasani, S. (2005). Vitrification : will it replace the conventional gamete cryopreservation techniques ?, *Middle East Fertility Society Journal* 10(3): 171–184.
- ORIGIO - <http://www.origio.com/> (n.d.).
- Papis, K., Shimizu, M. & Izaike, Y. (2000). Factors affecting the survivability of bovine oocytes vitrified in droplets, *Theriogenology* 54(5): 651–658.  
URL: <http://linkinghub.elsevier.com/retrieve/pii/S0093691X00003800>
- Pegg, D. E. (2005). The role of vitrification techniques of cryopreservation in reproductive medicine, *Human Fertility* 8: 231–239.
- Planer Controlled Rate Freezer - <http://www.planer.co.uk/> (n.d.).

- Popescu, G., Radcenco, V., Gargalian, E. & Ramany Bala, P. (2001). A critical review of pulse tube cryogenerator, *International Journal of Refrigeration* 24: 230–237.
- Reubinoff, B. E., Pera, M. F., Vajta, G. & Trounson, a. O. (2001). Effective cryopreservation of human embryonic stem cells by the open pulled straw vitrification method., *Human reproduction (Oxford, England)* 16(10): 2187–94.  
URL: <http://www.ncbi.nlm.nih.gov/pubmed/11574514>
- Rezazadeh Valojerdi, M., Eftekhari-Yazdi, P., Karimian, L., Hassani, F. & Movaghar, B. (2009). Vitrification versus slow freezing gives excellent survival, post warming embryo morphology and pregnancy outcomes for human cleaved embryos., *Journal of assisted reproduction and genetics* 26(6): 347–54.  
URL: <http://www.pubmedcentral.nih.gov/articlerender.fcgi?artid=2729856&tool=pmcentrez&rendertype=abstract>
- Riabzev, S., Veprik, A., Vilenchik, H. & Pundak, N. (2009). Vibration generation in a pulse tube refrigerator, *Cryogenics* 49(1): 1–6.  
URL: <http://linkinghub.elsevier.com/retrieve/pii/S001122750800115X>
- Rosendahl, M., Schmidt, K. T., Ernst, E., Rasmussen, P. E., Loft, A., Byskov, A. G., Andersen, A. N. & Andersen, C. Y. (2011). Cryopreservation of ovarian tissue for a decade in Denmark: a view of the technique., *Reproductive biomedicine online* 22(2): 162–71.  
URL: <http://www.ncbi.nlm.nih.gov/pubmed/21239230>
- Roth, T. L., Bush, L. M., Wildt, D. E. & Weiss, R. B. (1999). Scimitar-horned oryx (*Oryx dammah*) spermatozoa are functionally competent in a heterologous bovine in vitro fertilization system after cryopreservation on dry ice, in a dry shipper, or over liquid nitrogen vapor., *Biology of reproduction* 60(2): 493–8.  
URL: <http://www.ncbi.nlm.nih.gov/pubmed/9916019>
- Scollo, L., Valdez, P. & Baron, J. (2008). Design and construction of a Stirling engine prototype, *International Journal of Hydrogen Energy* 33(13): 3506–3510.  
URL: <http://linkinghub.elsevier.com/retrieve/pii/S0360319908000098>
- Sheehan, C. B., Lane, M. & Gardner, D. K. (2006). The CryoLoop facilitates re-vitrification of embryos at four successive stages of development without impairing embryo growth., *Human reproduction (Oxford, England)* 21(11): 2978–84.  
URL: <http://www.ncbi.nlm.nih.gov/pubmed/16950825>
- Smith, G. D., Serafini, P. C., Fioravanti, J., Yadid, I., Coslovsky, M., Hassun, P., Alegretti, J. R. & Motta, E. L. (2010). Prospective randomized comparison of human oocyte cryopreservation with slow-rate freezing or vitrification., *Fertility and sterility* 94(6): 2088–95.  
URL: <http://www.ncbi.nlm.nih.gov/pubmed/20171613>
- Stanic, P., Tandara, M., Sonicki, Z., Simunic, V., Radakovic, B. & Suchanek, E. (2000). Comparison of protective media and freezing techniques for cryopreservation of human semen., *European journal of obstetrics, gynecology, and reproductive biology* 91(1): 65–70.  
URL: <http://www.ncbi.nlm.nih.gov/pubmed/10817881>
- Stănescu Pascal, M. & Birțoiu, A. I. (2010). Comparative Studies of Canine Semen Freezing Protocols, *Veterinary Medicine* 67(2): 209–215.
- Suárez, V. J., Goodnight, T. W. & Hughes, W. O. (2003). Vibration Modal Characterization of a Stirling Convertor via Base-Shake Excitation, *the Proceedings of the International Energy Conversion Engineering Conference, Portsmouth, Virginia*, number November.  
URL: <http://gltrs.grc.nasa.gov/reports/2003/TM-2003-212479.pdf>
- Suzuki, T., Tomaru, T., Haruyama, T., Sato, N., Yamamoto, A., Shintomi, T., Ikushima, Y. & Li, R. (2006). Pulse tube cryocooler with self-cancellation of cold stage vibration, *Cryo*

- Prague 2006.  
URL: <http://arxiv.org/abs/physics/0611031>
- Tedder, R., Zuckerman, M., Brink, N., Goldstone, A., Fielding, A., Blair, S., Patterson, K., Hawkins, A., Gorman, A., Heptonstall, J. & Others (1995). Hepatitis tank B transmission from contaminated cryopreservation, *The Lancet* 346(8968): 137–140.  
URL: <http://linkinghub.elsevier.com/retrieve/pii/S014067369591207X>
- Vajta, G. & Kuwayama, M. (2006). Improving cryopreservation systems., *Theriogenology* 65(1): 236–44.  
URL: <http://www.ncbi.nlm.nih.gov/pubmed/16289262>
- Valbuena, D., Sánchez-Luengo, S., Galán, A., Sánchez, E., Gómez, E., Poo, M. E., Ruiz, V., Genbacev, O., Krtolica, A. & Pellicer, A. (2008). Efficient method for slow cryopreservation of human embryonic stem cells in xeno-free conditions, *Reproductive BioMedicine Online* 17(1): 127–135.  
URL: <http://linkinghub.elsevier.com/retrieve/pii/S1472648310603021>
- van den Abbeel, E., van der Elst, J., van der Linden, M. & van Steirteghem, a. C. (1997). High survival rate of one-cell mouse embryos cooled rapidly to -196 degrees C after exposure to a propylene glycol-dimethylsulfoxide-sucrose solution., *Cryobiology* 34(1): 1–12.  
URL: <http://www.ncbi.nlm.nih.gov/pubmed/9028912>
- Varghese, A. C., Nagy, Z. P. & Agarwal, A. (2009). Current trends, biological foundations and future prospects of oocyte and embryo cryopreservation, *Reproductive BioMedicine Online* 19(1): 126–140.  
URL: <http://linkinghub.elsevier.com/retrieve/pii/S1472648310600569>
- Vutyavanich, T., Piromlertamorn, W. & Nunta, S. (2010). Rapid freezing versus slow programmable freezing of human spermatozoa., *Fertility and sterility* 93(6): 1921–8.  
URL: <http://www.ncbi.nlm.nih.gov/pubmed/19243759>
- Vutyavanich, T., Sreshthaputra, O., Piromlertamorn, W. & Nunta, S. (2009). Closed-system solid surface vitrification versus slow programmable freezing of mouse 2-cell embryos., *Journal of assisted reproduction and genetics* 26(5): 285–90.  
URL: <http://www.pubmedcentral.nih.gov/articlerender.fcgi?artid=2719071&tool=pmcentrez&rendertype=abstract>
- Wang, C. & Hartnett, J. G. (2010). A vibration free cryostat using pulse tube cryocooler, *Cryogenics* 50(5): 336–341.  
URL: <http://linkinghub.elsevier.com/retrieve/pii/S0011227510000044>
- Ware, C. B., Nelson, A. M. & Blau, C. A. (2005). Controlled-rate freezing of human ES cells., *BioTechniques* 38(6): 879–80, 882–3.  
URL: <http://www.ncbi.nlm.nih.gov/pubmed/16018548>
- Wilding, M. G., Capobianco, C., Montanaro, N., Kabili, G., Di Matteo, L., Fusco, E. & Dale, B. (2010). Human cleavage-stage embryo vitrification is comparable to slow-rate cryopreservation in cycles of assisted reproduction., *Journal of assisted reproduction and genetics* 27(9-10): 549–54.  
URL: <http://www.pubmedcentral.nih.gov/articlerender.fcgi?artid=2965340&tool=pmcentrez&rendertype=abstract>
- Yaqi, L., Yaling, H. & Weiwei, W. (2011). Optimization of solar-powered Stirling heat engine with finite-time thermodynamics, *Renewable Energy* 36(1): 421–427.  
URL: <http://linkinghub.elsevier.com/retrieve/pii/S0960148110003101>

# Methods of Assessment of Cryopreserved Semen

Agnieszka Partyka, Wojciech Nizański and Małgorzata Ochota  
*Wroclaw University of Environmental and Life Sciences  
Poland*

## 1. Introduction

The numerous effects that cryopreservation can induce in spermatozoa, ranging from lethal injuries to those which merely impair their subsequent function. In the last few years, the considerable increase in our understanding of both, the cell physiology of spermatozoa, and the stress of cryopreservation, have contributed to a renewed interest in improving the performance of cryopreserved semen.

Despite the significant progress, the post-thaw viability and fertility of the cryopreserved sperm are still reduced, as a consequence of accumulated cellular injuries that arise throughout the cryopreservation process. Many laboratory tests have already been carried out to verify these detrimental effects and their origin. Their is needed to well understand the whole process of cryopreservation and its influence on sperm function. As a consequence, it would lead to a subsequent improvement of sperm viability by means of reformulated protocols and approaches helping to minimize the detrimental effect of cryopreservation.

Here, we present an overview of the cryopreserved semen assessment methods in the light of sperm physiology, in order to relate these factors to altered functions of cryopreserved sperm and to determine the fertilizing potential of the frozen-thawed semen.

## 2. Conventional methods of semen assessment

Light microscopy is the most often used to analyze the quality and predict the fertility of the cryopreserved semen in the conventional way. Visual assessment requires such equipment as microscope, heated stage and slides, as well as an experienced evaluator, however the assessment is subjected to the evaluator bias.

### 2.1 Sperm motility

Motility is one of the most important features of a fertile spermatozoa. It was the first, and continues to be the most widely used indicator of sperm function. Sperm motility is an important attribute, because it is readily identifiable and reflects several structural, and functional competence, as well as essential aspects of spermatozoa metabolism. Sperm motility is expressed as the percentage of total motile or progressively motile spermatozoa. This parameter is usually assessed by the subjective visual examination under a phase contrast microscope at 37°C using low objectives (10 or 20x). Light microscopic evaluation

of motile spermatozoa does not require expensive equipment, is a simple and rapid method for assessment of sperm quality, however, it is a highly subjective and not reliable assay for the prediction of fertility (Peña Martínez, 2004).

## 2.2 Sperm morphology

On account of the fact that freezing and thawing process provokes morphological or biochemical cryogenic damage resulting in sperm dysfunction and changes in cell's membrane, the sperm morphology evaluation is an essential component of any semen analysis and provides the clinical information about the potential fertility of semen sample.

Despite, there are many different and also new methods, as described below, used in semen analysis, semen smears are still employed for routine light microscopic morphological evaluation. However, this assessment is subjective and results are largely dependent on the proficiency and experience of the evaluator. Vital dye in combination with different stains for acrosome evaluation are commonly utilised to assess the spermatozoa morphology and the viability together. For this purpose, India ink, William's, Karras, Spermac, Diff-Quick, Papanicolaou, Fielgen or combination: Trypan blue and Giemsa, Trypan blue, Bismarck Brown and Rose Bengal, and finally eosin-nigrosin (described in 2.3 section) have been used in birds and mammals including human (Brito et al., 2003; Brito et al., 2011; Didion et al., 1989; Freneau et al., 2010; Łukaszewicz et al., 2008; Partyka et al., 2007; Rodriguez-Gil et al., 1994; Sprecher & Coe, 1996; Talbot & Chacon, 1981). In spite of that, Freneau et al. (2010) have shown that differential interference phase contrast microscopy of wet-mounted semen is the superior method for bulls sperm morphology assessment. For cats sperm morphology, the best differentiation of sperm structures, especially acrosome, with lower artifacts, fast green FCF-rose Bengal staining or Hancock and Glendhill solution staining and phase-contrast microscope are encouraged (Zambelli & Cunto, 2006). However, when frozen-thawed semen is analyzed these stains are negatively affected by egg yolk and glycerol, causing egg yolk agglutination and lack of sperm structures differentiation. Therefore, sperm washing is recommended to prevent these interferences (Zambelli & Cunto, 2006).

Many reports have shown the common classification system for the morphology of spermatozoa from different species. However, classification categories are different for the various species and the adoption of uniform system within each species is needed. Mammalian spermatozoa abnormalities can be divided into primary and secondary abnormalities (Blom, 1950), or in some classification systems into major and minor abnormalities (Blom, 1968, 1983). Primary sperm defects are assumed to have occurred during spermatogenesis, and secondary defects are assumed to have occurred during maturation in the epididymis and the transit through the ductal system and specimen preparation. Second system classifies sperm defects according to the perceived effects on fertility. The most common sperm abnormalities (Fig. 1) are related to abnormal acrosomal regions/heads, detached head, proximal droplets, distal droplets, abnormal midpieces, bent/coiled tails. Acrosome defects include knobbed, roughed, and detached acrosomes. Head defects include microcephalic, macrocephalic, pyriform, tapered, other shape defects, nuclear vacuoles, and multiple heads. Midpiece and principal piece (tail) abnormalities enclose simple bent, folded, fractured, thickened, swollen, roughed, Dag-like, disrupted sheet, duplicated, coiled. Various defects are typical for each species.

For each slide, at least 100-300 spermatozoa should be counted at 400-1000x magnification, which allows for accurate calculation of the percentage of different sperm defects.



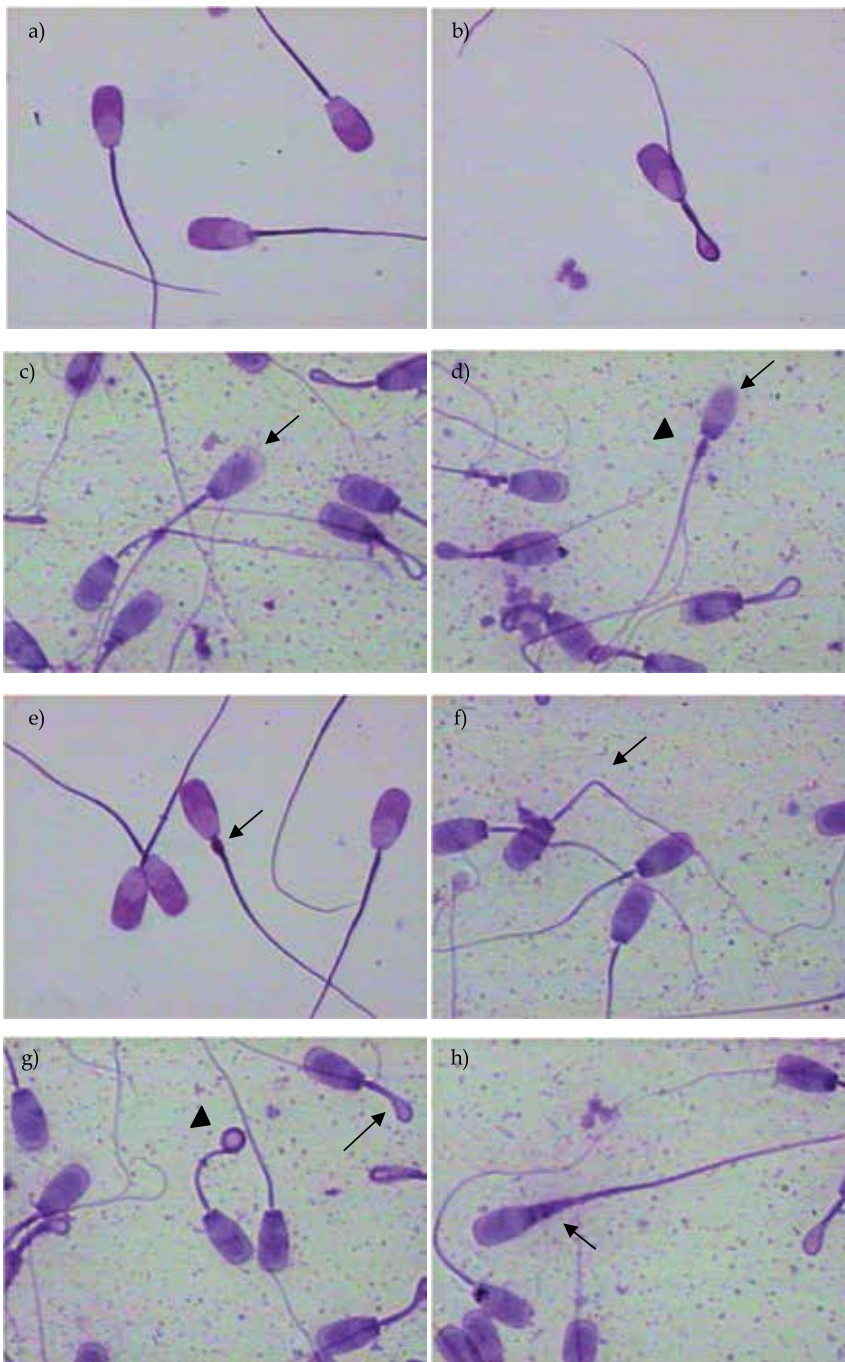

Fig. 1. Selected defects in sperm morphology (boar spermatozoa): a) normal sperm cells; b) looped tail; c) acrosome detachment; d) loss of acrosomal contents (back arrow), proximal cytoplasmic droplet (arrowhead); e) proximal cytoplasmic droplet; f) kinked midpiece; g) looped tail (black arrow), coiled tail (arrowhead); h) thickened midpiece.

### 2.3 Sperm membrane integrity

**Live-dead staining.** The traditional method for assessing whether the sperm membrane is intact or disrupted involves examining a percentage of viable sperm by a stain exclusion assay. For the determination of cell viability live-dead stains as aniline-eosin, eosin-nigrosin or eosin-fast green are widely used. Integrity of the plasma membrane is shown by the ability of a viable cell to exclude the dye, whereas the dye will diffuse passively into sperm cells with damaged plasma membranes. When stained smears are viewed under the oil immersion objective of light microscope, the percentage of viable, live, properly formed spermatozoa, nonviable and also partially-damaged spermatozoa can be determined. In eosin-nigrosin stain under the microscope, live spermatozoa appear white, unstained against the purple background of nigrosin (Fig. 2a). Dead and damaged spermatozoa which have a permeable plasma membrane are pink (Fig. 2b). The evaluation of the percentage of live and dead spermatozoa and the percentage of morphology defects may be performed on the same nigrosin-eosin stained slides.

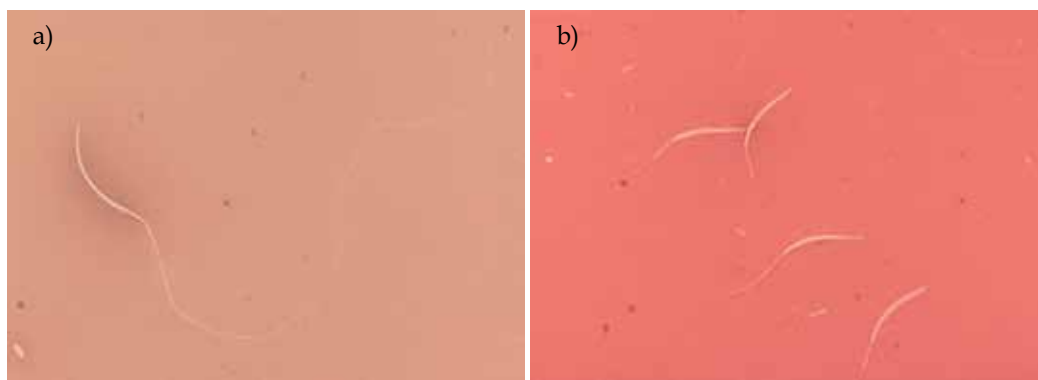

Fig. 2. Eosin-nigrosin staining for live-dead cells (chicken spermatozoa): a) live spermatozoon, b) dead spermatozoa.

**The hypoosmotic swelling test (HOS)** is a method of investigating membrane integrity in sperm and, as such, is an alternative to supra-vital staining. In fact, the HOS test is thought to have the advantage of indicating not only whether the membrane is intact, but also whether it is osmotically active. Sperm with an intact, functional membrane when are exposed to an hypoosmotic solution incubated for 30 minutes at 37°C, swell to achieve an osmotic equilibrium. An expression of this is a typical swelling of the sperm tail (Fig. 3) (Neild et al., 1999). The HOS test is a simple, inexpensive and easily applicable technique, which has been adapted to assess spermatozoa of several species (Corea & Zavos, 1994; Kumi-Diaka, 1993; Neild et al., 1999; Pérez-Llano et al., 2001; Santiago-Moreno et al., 2009). It has been suggested that this test may supplement the information provided by the conventional parameters of semen analysis, and is useful for fertilizing ability assessment (Brito et al., 2003; Vazquez et al., 1997). This test correlates highly with other predictive tests, such as hamster oocyte penetration (Jeyendran et al., 1992), in-vitro fertilization (IVF) results in human (van der Venn et al., 1986), and with pregnancy rates in pigs (Pérez-Llano et al., 2001). The HOS test seems to be more appropriate for predicting the fertilizing capacity of frozen-thawed than fresh semen, because membrane damage is here a more important limiting factor than in the former (Colenbrander et al., 2003).



Fig. 3. HOS test (canine spermatozoa).

### 3. Advanced methods of semen assessment

#### 3.1 Computer assisted sperm analysis (CASA)

Recently, computer assisted sperm analysis has been introduced to veterinary andrology, same as it has been used in reproductive technologies in human andrology (Rijsselaere et al., 2003; Verstegen et al., 2002). This technique assures objective semen assessment, whereas the main disadvantage of conventional semen evaluation is variability of obtained results. Subjectivity of traditional semen analysis is associated mainly with experience and skill of the observer, the method of specimen preparation, staining technique and number of cells evaluated. Variations in the results of conventional evaluation of the same semen samples by different observers and laboratories may achieve up to 30-60% (Coetzee et al., 1999; Davis & Katz, 1992). Subsequently, correlations between spermatozoa characteristics and fertility trials in females are relatively low. Computer assisted sperm analysers allow for calculation of several motility parameters, which characterize movement of individual sperm cells. They include VAP-average path velocity, VSL-straight line velocity, VCL-cell velocity, ALH-amplitude of lateral head displacement, BCF-beat cross frequency (Fig. 4), STR-straightness of cell track, LIN-linearity of cell track, subpopulation of rapid, medium and slow cells (Nizański et al., 2009). Selected characteristics of spermatozoa motility parameters measured by CASA systems are summarized in table 1.

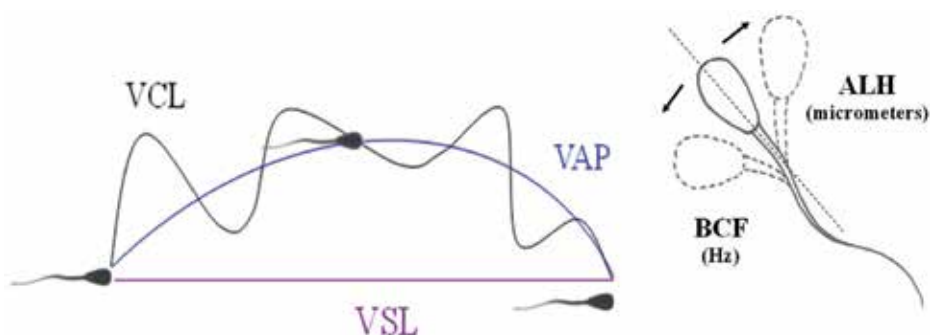

Fig. 4. Scheme of different velocities and parameters of sperm movement measured by CASA systems.

Parameter	Unit	Description
MOT	%	Motility - The population of cells that are moving at or above a minimum speed as determined by values defined under setup.
PMOT	%	Progressive motility- the population of cells that are moving actively forward.
VCL	$\mu\text{m/s}$	Track speed - Is defined as average velocity measured over the actual point-to-point track followed by the cell.
VAP	$\mu\text{m/s}$	Path velocity - Is defined as average velocity over smoothed average position of the cell.
VSL	$\mu\text{m/s}$	Progressive velocity - Is measured in the straight line distance between the beginning and the end of the track.
ALH	$\mu\text{m}$	Amplitude of Lateral Head Displacement - is the mean width of the head oscillation as the cell moves.
BCF	Hz	Beat Cross Frequency - is the frequency with which the sperm head moves back and forth in its track across the cell path.
STR	%	Straightness - A measure of VCL side to side movement determined by the ratio $VSL/VAP$ .
LIN	%	Linearity - A measure of the departure of the cell track from a straight line. It is the ratio $VSL/VCL$ .
RAP	%	Rapid - subpopulation of rapid cells.
MED	%	Medium - subpopulation of cells with medium velocity.
SLOW	%	Slow - subpopulation of slow cells.
STATIC	%	Static cells.

Table 1. Selected parameters of spermatozoa motility measured by CASA systems.

It was proven in human, that results obtained with CASA systems are better correlated with the outcome of assisted reproductive techniques than results of traditional semen evaluation (Verstegen et al., 2002). Blesbois et al. (2008) showed that some of parameters detected in CASA system are correlated with fertility results obtained with frozen-thawed chicken spermatozoa (PMOT, PROG, VAP, VSL). Most of them were affected by cryopreservation, with the exception of straightness (STR), suggesting that cryopreservation slows down the movement of chicken spermatozoa without changing the shape of trajectories.

The important advantage of computer assisted sperm analysers is the immediate measurement of sperm concentration, total number of sperms in ejaculate and the automated calculation of number of insemination units which could be prepared from one ejaculate. Additionally some machines are equipped with UV excitation module, which gives the opportunity to analyse the percentage of live and dead spermatozoa after staining with vital fluorescent probes, such as Hoechst 33258. Nevertheless, CASA system needs standardization and validation before its use and image settings have been standardized

(Davis & Katz, 1992; Iguer-Ouada & Versteegen, 2002; Rijsselaere et al., 2003; Versteegen et al., 2002). Also other factors as the type and depth of the used chamber, number of fields analysed, temperature during analysis and protocol of semen sample preparation affect results. Optimization and validation of the technical settings would allow to compare intra- and inter-laboratory results, regardless of the instruments that have been used (Agarwal et al., 1992).

Computer assisted sperm analysis allows for a detailed estimation of subtle changes of sperm motion characteristics such as hyperactivation (HA) of spermatozoa associated with capacitation process. Hyperactivation is the process that mammalian spermatozoa exhibit, while they progress through the female oviduct. It is described as vigorous, non-progressive, non-linear sperm motion linked with capacitation. During HA, the pattern of sperm track undergo dramatic changes, characterized by wide-amplitude marked lateral movements of the head and tail of the spermatozoon, with slow or non-progressive 'star-pin' movement (Versteegen et al., 2002). Hyperactivated sperm movement, is assumed to be necessary, for mammalian sperms to penetrate into and pass through, the cumulus cell layer of an oocyte (Meyers et al., 1997; Suarez et al., 1983). To fertilize the oocyte, mammalian spermatozoa must be capacitated, the process that depends on the removal or alteration of substances absorbed on, or integrated in the sperm plasma membrane, resulting in changes in membrane permeability and intracellular ionic composition, with  $\text{Ca}^{2+}$  movements playing the most critical role (Fraser et al., 1995; Rota et al., 1999). ALH and velocity parameters such as path velocity VAP, progressive velocity VSL are increased in hyperactivated spermatozoa, whereas linearity LIN and straightness STR of movement are lowered. Such changes are characteristic for capacitation induced by specific media (Rota et al., 1999) and for spermatozoa that underwent preservation (cryocapacitation) and are pronounced, especially when media with addition of detergents are used (Nizański et al., 2009). Kawakami et al. (2001) observed that oviduct's epithelium possess the ability to bind hyperactivated spermatozoa, which results in the obvious prolongation of their flagellar movement. On the other hand, the life-span of the free moving non-bound hyperactivated spermatozoa within oviductal lumen, is relatively shorter. It was also found, that Ca influx into the cytoplasm is inhibited in the oviduct-epithelium-binding sperms (Dobrinsky et al., 1997). Active movement of the sperms and Ca influx into cytoplasm negatively affect the maintenance of viability and fertile life of sperm in the lumen of oviduct. Binding to the oviduct epithelium presumably prevents Ca influx, required for sperm capacitation. This phenomenon is available for prolonging viability and fertile life of canine sperms in the oviduct (Kawakami et al., 2001). Considering the obvious lack of such regulatory mechanism, in frozen-thawed semen it is believed, that *in vitro* post-thaw hyperactivation results in depletion in spermatozoa energy resources, accumulation of metabolites in the extender and cell death, if insemination dose is not deposited into the female's genital tract immediately after thawing.

Nevertheless, the computer assisted sperm analysis of cryopreserved semen should be treated with a dose of criticism. It should be emphasized, that CASA parameters describing kinematic features of frozen-thawed sperm cells may not reflect the real loss of quality of ejaculate after treatment. Absolute CASA parameters (VCL, VSL, VAP, ALH, BCF) should be used with caution, whereas relative CASA parameters (combinations of absolute

features-LIN, STR) can not be used directly for estimation of semen quality. Selective death of the most immotile and weakened spermatozoa leads to the situation, where normal CASA parameters show the 'pseudoenhancement' of kinematics. Thus, the mean velocity and linearity parameters may be higher after freezing. This is caused by the fact, that the sub-population of the most resistant cells which survive freezing-thawing may possess higher mean quality parameters, than the larger population of motile sperm cells in fresh semen. In spite of the fact, that only half or one third of population of sperm cells may survive the cryopreservation, their mean velocity may be higher in comparison with velocity parameters of larger population of spermatozoa in fresh semen. Thus, some investigators (Katkov & Lulat, 2000) observed increase in kinematic parameters (KP) of specimen after freezing-thawing, while at the same time substantial losses in post-thaw motility (percentage of motile cells) were observed. The possible explanation of this phenomenon is the selective elimination of the slowest sub-population within the specimens. This "CASA-paradox" is caused by substantial exclusion of slow-moving cells from the motile fraction measured after freezing-thawing.

Therefore, in order to obtain more reliable results of semen assessment after thawing, it was proposed to use Modified Kinematics Parameters (MKP) or Yield of Kinematic Parameters (YKP). MKP can be defined as KP that is average on an entire sample:

$$\text{MKP} = \text{KP} \times \text{Motility} / 100\% \quad (1)$$

YKP is the product of KP and the number of motile cells for which this parameter is average:

$$\text{YKP} = \text{Total Number of Motile Cells} \times \text{KP} / 100\% \quad (2)$$

Furthermore, morphology (Assisted Sperm Morphology Assessment-ASMA) of sperm cells can be objectively evaluated, on the basis of morphometric analysis of predefined specific measurements of particular elements in spermatozoa. Usually, on the slides, the head morphometric dimensions of length, width, width/length, area and perimeter of a minimum of 200 sperm are analyzed (Fig. 5). Additionally, parameters of head shape can be evaluated such as ellipticity, circularity, elongation, and regularity (Álvarez et al., 2008). Nevertheless, the accuracy of sperm morphology assessment depends on the careful preparation, fixation and staining of spermatozoa. The analysis of sperm morphology may be done using Diff-Quik stain recommended by World Health Organization (WHO, 2010) or SpermBlue, which has been developed for the evaluation of human and animal sperm morphology (Maree et al., 2010).

Rubio-Guillen et al. (2007) showed that by applying ASMA techniques and multivariate cluster analysis, it is possible to determine three subtle subpopulations of spermatozoa with different morphometric characteristics coexisting in bull ejaculates. The proportion of spermatozoa in each sperm subpopulation showed considerable differences among males and varied significantly throughout the cryopreservation procedure. The cryopreservation of spermatozoa has been found to affect chromatin structure and morphometry of the sperm head (Arruda et al., 2002; Estes et al., 2003; Gravance et al., 1998; Hidalgo et al., 2006; Rijsselaere et al., 2004). Thus, it is presumed that the adverse effects of cryopreservation on sperm chromatin and head morphology, may be responsible for lowered fertility of spermatozoa, observed after cryopreservation.

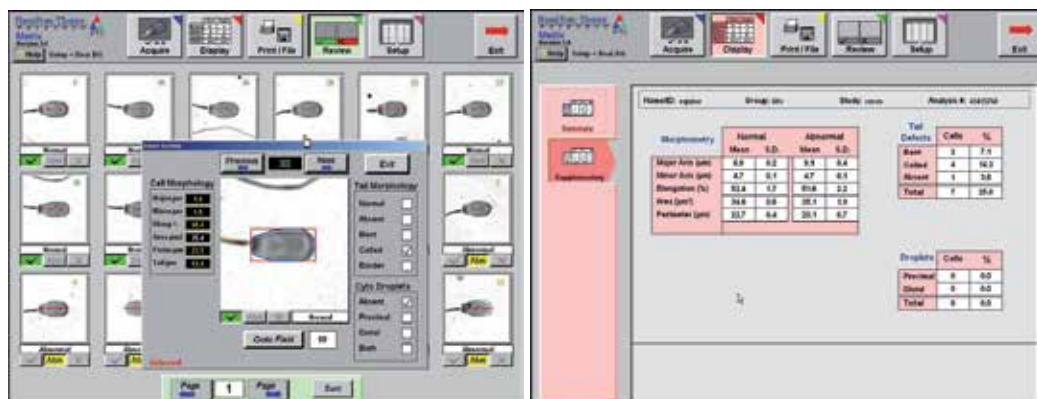

Fig. 5. System for Assisted Sperm Morphology Assessment.

### 3.2 Flow cytometry and fluorescent probes

During last decades many fluorescent probes have been used for the semen assessment. The fluorescence of these compounds may be estimated using fluorescent microscopy or flow cytometry. Flow cytometry enables the observation of physical characteristics such as cell size, shape, and also any component or function of the spermatozoon that can be detected by a fluorochrome or fluorescently labeled compound. The analysis is objective and accurate. The great number of spermatozoa (>10 000) can be analyzed in a small volume of samples in a short time. This is considerably more than the total of 200 cells generally observed by microscopic analysis. Thus, the analysis of events detected on dot plots gives the accurate and high reliable results (Peña et al., 2001). It is a sensitive method of detection of subtle differences among spermatozoal populations that may not be detected with other techniques.

#### 3.2.1 Sperm membrane integrity

The integrity of sperm membranes is a necessary condition to maintain spermatozoal functions during storage in the female's reproductive tract and penetration of the oocyte (Holt, 2000). When semen is frozen, cells are exposed to a cold shock, ice crystals formation, and cellular dehydration, which all cause irreversible damage (Amann, 1999; Parks & Graham, 1992). Cellular membranes are one of the primary sites of injury during chilling, freezing and thawing. Damage is caused by alteration of membrane structure and lateral organization (Amann, 1999). The cryopreservation results in temperature-dependent and dehydration-induced membrane phase changes, which are thought to result in lateral phase separation of membrane components and increased membrane permeability for solutes (Hammerstedt et al., 1990). The disruption of plasma membrane integrity caused by disarrangement of lipids within the membrane during cryopreservation may induce further cellular damage and consequently lead to a sperm death (Watson, 1995).

Membrane integrity of mammalian and avian spermatozoa may be assessed by using many fluorescent probe combinations including: carboxyfluorescein diacetate (CFDA) in combination with propidium iodide (PI), SYBR-14 with PI, carboxy-seminaphthorhodfluor (Carboxy-SNARF) with PI, calcein-AM with ethidium homodimer (EthD-1) and Hoechst

33258 (Christensen et al., 2004; Donoghue et al., 1995; Hewitt & England, 1998; Partyka et al., 2010; Peña et al., 1998; Rijsselaere et al., 2005; Sirivaidyapong et al., 2000). SYBR-14 and CFDA, usually used detectors of live cells, are membrane-permeant and non-fluorescent compounds, which are immediately deacylated and thus rapidly converted into high fluorescent compounds by intracellular esterases. These green fluorochromes are maintained intracellularly by intact membranes (Peña et al., 1998; Silva & Gadella, 2006). As plasma membrane deteriorates at cell death, cells lose their ability to resist the influx of red fluorescent PI. PI replaces or quenches green fluorochromes (Garner & Johnson, 1995). Live, viable, intact spermatozoa show a green fluorescence (CFDA, SYBR-14, calcein-AM) while dead stain red (PI) (Fig. 6a). Carboxy-SNARF is a pH indicator which stains live spermatozoa orange, while bisbenzimidazole stain Hoechst 33258 labels dead spermatozoa bright blue (Hewitt & England, 1998). The last one requires flow cytometric analysis with a laser that operates in the ultraviolet light range and is less commonly used in andrology laboratory, however alternatively it may be applied within a fluorescent microscope.

SYBR-14/PI fluorochromes have been found to be more sensitive in comparison with conventional methods of live-dead cell assessment. The advantage of the use of fluorochromes is the possibility to assess the semen without the interference of fat particles and other material present in the extended semen (Rijsselaere et al., 2005). The detection of the third subpopulation i.e. moribund spermatozoa is the next advantage of this method. Additionally, the simultaneous assessment of several functions of spermatozoa may be done in the same specimen by simultaneous staining of sperm cells with fluorescent lectins PNA or PSA for acrosome evaluation with PI for dead cell assessment.

### 3.2.2 Acrosomal membrane integrity

Acrosome is the acidic secretory organelle filled with hydrolytic enzymes. Assessment of the acrosomal status is a very important part of semen evaluation, in the view of the role of this structure in the maintenance of spermatozoal ability to penetrate the egg's zona pellucida (in mammals), or the egg envelope (in birds) and the ability to fuse with the egg plasma membrane. Cells must retain a normal acrosome to ensure that the acrosome reaction may occur at the suitable time to facilitate fertilization (Esteves et al., 2007). Also, the determination of the acrosome status in cryopreserved sperm is of fundamental importance as cryopreservation directly damages sperm membrane, which could be followed by a loss of the acrosomal matrix contents.

Acrosomal status may be assessed using lectins, such as peanut agglutinin from *Arachis hypogaea* (PNA) or *Pisum Sativum* agglutinin (PSA), conjugated with different fluorescent probes like fluorescein isothiocyanate (FITC), phycoerythrin (PE) or Alexa Fluor®, (Graham et al., 1990; Kawakami et al., 2002; Nagy et al., 2004; Partyka et al., 2010; Peña et al., 2001; Rijsselaere et al., 2005). For human sperm concanavalin A lectins (ConA) is used as well (Holden et al., 1990). The PNA labelling is specific for the outer acrosomal membrane and it binds to  $\beta$ -galactose moieties. Whereas the PSA is labelling  $\alpha$ -mannose and  $\alpha$ -galactose moieties of the acrosomal matrix. The absence of the fluorescence on the living sperm is indicative for an intact acrosome, and fluorescence is indicative for acrosome disruption or acrosome reaction (Silva & Gadella, 2006). Since PNA agglutinin displays less non-specific binding to other areas of the spermatozoa, it leads some researchers to favour this over PSA (Graham, 2001). Lectins may be also combined with Hoechst 33258, carboxy-SNARF/PI,



ethidium homodimer allowing for simultaneous assessment of acrosomal status and membrane integrity (Fig. 6b) (Kawakami et al., 1993; Szász et al., 2000).

### 3.2.3 Mitochondrial function

The motility of spermatozoa subjected to cryopreservation is reduced by reason of some changes in the active transport and the permeability of the plasma membrane in the tail region (Blesbois et al., 2008; Watson, 1995). A reduction of spermatozoa motility may also be triggered by a change in the availability of energy or an injury of the axonemal elements. Moreover, it has been noted that the alterations in the ultrastructure of mitochondria occurring during cryopreservation are followed by a loss of the internal mitochondrial structure of frozen-thawed spermatozoa (Watson, 1995).

Rhodamine 123 (R123) is the potentiometric membrane dye which is used to selectively stain functional mitochondria. It fluoresces only when the proton gradient over the inner mitochondrial membrane (IMM) is built up and unstained sperm do not contain functional mitochondria (Garner et al., 1997; Gravance et al., 2001). Also the group of Mitotracker: Mitotracker Deep Red, Red, Orange and Green selectively label the respiring mitochondria. Thus, these probes are suitable to discriminate sperm with deteriorated mitochondria from sperm in which oxidative respiration occurs (Gadella & Harrison, 2002; Garner et al., 1997).

Some of mitotracker such as 5,5',6,6'-tetrachloro-1,1',3,3'-tetraethylbenzimidazolyl-carbocyanine iodide (JC-1) change their fluorescent properties due to changes in the potential of IMM. JC-1 is a lipophilic cationic fluorescent carbocyanine dye that is internalized by all functioning mitochondria, where it fluoresces green. However, as the concentration of JC-1 inside the mitochondria increases (highly functional mitochondria), the stain forms aggregates which fluoresce orange. Hereby, population of spermatozoa can be divided into high (orange staining), moderate (orange and green) and low (green) mitochondrial potential groups after IMM depolarisation (Fig. 6c) (Garner et al. 1999; Gravance et al., 2000).

### 3.2.4 Capacitation status

Before fertilizing of the oocyte, mammalian spermatozoa undergo the sequence of membrane alterations associated with accumulation of calcium ion and the increase of tyrosine phosphorylation resulting in sperm hyperactivation (Hewitt & England, 1998; Petrunkina et al., 2003). At the contact with oocyte, capacitated spermatozoa presents the acrosome reaction which enables the zona pellucida penetration. However, in avian spermatozoa it is believed that a period of capacitation within the female's reproductive tract in order to fertilize ova is not required (Howarth, 1971). The hen oocyte is not surrounded by cumulus cells that would require a different way of sperm motility to pass them through. It may therefore be suggested that there is no need for motility hyperactivation to prepare for the acrosome reaction in the chicken and that this special motility pattern has not been developed in birds (Lemoine et al., 2008).

The capacitation of the mammalian spermatozoa is assessed by using chlorotetracycline assay (CTC), lectins, measurements of CASA motility characteristics and assessment of tyrosine phosphorylation within plasma membrane (Guérin et al., 1999; Hewitt & England,

1998; Petrunkina et al., 2004; Rota et al., 1999). Fluorescent antibiotic CTC is used to assess the destabilization of sperm membrane. Neutral and uncomplexed CTC crosses over the cell membrane, enters intracellular compartments and binds to free calcium ions. During these events, CTC becomes negatively charged and after creating CTC-Ca<sup>2+</sup> complexes becomes more fluorescent. Thus CTC can be used as a tool to distinguish capacitated and uncapacitated spermatozoa. Three classes of sperm cells may be assessed: uncapacitated and acrosome intact (F-pattern, an overall staining of the sperm head), capacitated and acrosome intact (B-pattern, a prominent staining of the apical area of the sperm head) and capacitated and acrosome reacted (AR-pattern, loss of staining of the sperm head) (Maxwell & Johnson, 1997). CTC may be combined with Hoechst 33258, to simultaneous assessment of percentage of live cells and capacitation status (Hewitt & England, 1998).

The exposure of spermatozoa to low temperatures shortens their capacitation time, changing the membrane lipid architecture, membrane permeability and the reducing efficiency of enzymes extruding calcium ions. These changes resemble capacitation, and are likely to reduce long-term sperm viability and alter their motility (Watson, 1995). Therefore, the researchers have introduced the term “cryocapacitation” to emphasize the fact that cryopreservation procedures induce capacitation-like changes in spermatozoa (Bailey et al., 2000; Cormier & Bailey, 2003; Watson, 1995). These cooling-related capacitation-like changes in spermatozoa, may affect the fertility of cryopreserved semen, by rendering the cells less stable in the reproductive tract, after artificial insemination and therefore relatively short-lived. Such changes cannot easily be distinguished from true capacitation, but Green & Watson (2001) were able to establish that the capacitation-like changes in pig spermatozoa differed from true capacitation in the pattern of tyrosine phosphorylation of proteins.

An increase in both, plasma membrane phospholipid scrambling and phospholipid disorder, during capacitation is associated with enhanced plasma membrane fluidity (Gadella & Harrison, 2002). During freeze-thaw cycle, the sperm membranes undergo lipid phase transition that also leads to an increased disorder of phospholipid packing and membrane fluidity, which causes poor control of intracellular calcium concentration (Bailey & Buhr, 1994; Holt, 2000). Therefore, an alternative stain for assessment of capacitation status of spermatozoa is the hydrophobic probe Merocyanine 540 (M540). This stain detects a decreased packing order of phospholipids in the outer leaflet of the plasma membrane lipid bilayer. Due to the fact that M540 earlier detects changes in the membrane fluidity than CTC, therefore, the hydrophobic probe is believed to be better for evaluating the early events of capacitation (Rathi et al., 2001).

### 3.2.5 Lipid peroxidation

A content of polyunsaturated fatty acids (PUFAs) in phospholipids of spermatozoa membranes makes them especially susceptible to lipid peroxidation (LPO) (Aitken et al., 1993). LPO is a chain reaction with the formation of lipid peroxides and ultimately the formation of cytotoxic aldehydes (Aitken, 1995). In spermatozoa, peroxidation of lipids has critical consequences. Oxidation reactions in biomembranes lead to amplification of reactive oxygen species (ROS), change in membrane fluidity, loss of compartmentalization and plasma-membrane integrity, disturbance of ion-gradients, impairment of lipid-protein interactions, modification of DNA and proteins (Halliwell & Chirico, 1993).

Effect of oxidative stress is particularly important during the storage of sperm and its cryopreservation. The analysis of semen of mammalian and avian species, showed that the production of ROS and LPO occurrence is increased during freezing- thawing (Bilodeau et al., 2000; Chatterjee and Gagnon, 2001, Guthrie & Welch, 2007; Neild et al., 2005; Partyka et al., 2011b). The main site of their formation are mitochondria (Brouwers & Gadella, 2003) and sperm cell membranes (Agarwal et al., 2005), which are particularly vulnerable to damage from sudden temperature changes. Although, aerobic cells have substrates and enzymes to prevent or restrict the formation and propagation of ROS, but the antioxidant defence of spermatozoa are relatively weak and these germ cells are very susceptible to oxidative stress (Jones & Mann, 1977).

As an alternative to the colorimetric detection of lipid peroxide formation, a fluorescent membrane probe 4,4-difluoro-5-(4-phenyl-1,3-butadienyl)-4-bora-3a,4a-diaza-s-indacene-3-undecanoic acid ( $C_{11}$ -BODIPY<sup>581/591</sup>) has recently been successfully used in human, equine, bovine, porcine, feline and chicken's and goose's spermatozoa (Aitken et al., 2007; Almeida & Ball, 2005; Brouwers & Gadella, 2003; Brouwers et al., 2005; Neild et al., 2005; Partyka et al., 2011a,b; Thuwanut et al., 2009). This is an oxidation-sensitive fluorescent fatty acid analogue, that is easily incorporating into membranes and fluoresces red in the intact state, but turns green after undergoing peroxidation (Drummen et al., 2002).  $C_{11}$ -BODIPY<sup>581/591</sup> oxidation is virtually insensitive to environmental changes and the probe does not spontaneously leave the lipid bilayer after oxidation, moreover the extent of peroxidation is correlated with the formation of hydroxyl- and hydroperoxiphosphatidylcholine (Brouwers & Gadella, 2003; Brouwers et al., 2005). The degree of probe peroxidation can be followed in separate sperm subpopulations using flow cytometry, or localized in individual sperm using fluorescence microscopy. Moreover, the use of combination  $C_{11}$ -BODIPY<sup>581/591</sup> with PI makes it possible to distinguish the presence of reactive oxygen and nitrogen species in the hydrophobic part of lipid bilayers of live sperm from dead cell membranes (Fig. 6d).

For monitoring the intracellular level of ROS, such as hydrogen peroxide ( $H_2O_2$ ) in the spermatozoa, the fluorescent dye 5-(and-6)-carboxy-20,70-dichlorodihydrofluorescein diacetate (carboxy- $H_2DCFDA$ ) can be used. Viable spermatozoa are differentiated from dead cells by a counterstain - propidium iodide and the subpopulations of sperm with a high  $H_2O_2$  level (strong fluorescence) and with low  $H_2O_2$  level (weak fluorescence) can be distinguished.

### 3.2.6 Apoptotic changes

Apoptosis is a physiological mechanism required for any organism function. In contrast to necrosis, apoptosis is a process, where cells play an active role in their own death. Apoptosis comprising of a complex phenomenon that includes three stages: induction, execution and degradation. The most significant changes related to apoptosis are the externalization of the phosphatidylserine (PS), DNA fragmentation, caspase activation, loss of mitochondrial membrane potential, and increase in sperm membrane permeability (Bratton et al., 1997; Glander & Schaller, 1999; Martin et al., 2004;). Several pathways are reported for mammalian cell apoptosis. These include the intrinsic, extrinsic, and apoptosis-inducing factors. During the early phases of disturbed membrane function, asymmetry of the membrane phospholipids occurs, before the integrity of the plasma membrane is

progressively damaged (Martin et al., 1995). When the cell membrane is disturbed, the phospholipid PS is translocated from the inner to the outer leaflet of the plasma membrane (Desagher & Martinou, 2000).

It is widely known that the cryopreservation usually causes sublethal cryodamage to spermatozoa, decreasing post-thaw cell viability. The freezing-thawing of human (Glander & Schaller, 1999), bull (Martin et al., 2004), and boar (Pena et al., 2003), stallion (Ortega Ferrusola et al., 2008), and dog (Kim et al., 2010) spermatozoa induces membrane PS translocation, what demonstrates that cryopreservation leads to apoptosis. Therefore, detecting early phases of membrane dysfunction, or initial phases of apoptosis of viable spermatozoa, would be important when evaluating stressed spermatozoa, such as those subjected to freezing and thawing, and would be useful for controlling freezing procedures in semen.

Annexin V is calcium-dependent phosphatidylserine (PS) binding protein conjugated with fluorochrome - FITC or Alexa Fluor®. The properties of Annexin V allow for detection of externally exposed PS. In ejaculated spermatozoa PS is confined to the cytoplasmic side of the plasma membrane (Gadella et al., 1999). Different categories of apoptotic, necrotic and viable cells can then be sorted out using AnnexinV with PI, through flow cytometer (Fig. 6e), or visually evaluated using fluorescent microscope.

After induction of apoptosis, mitochondrial pores are being opened, leading to a decrease in mitochondrial membrane potential. Therefore, described above JC-1 dye is used for monitoring of apoptotic changes in spermatozoa, too (Ortega Ferrusola et al., 2009). Mentioned above, the opening of mitochondrial pores causes the release of proapoptotic factors into the cytoplasm, where they are activated. These factors - caspases, are central components in the apoptosis signaling cascade. The detection of activated caspases in living spermatozoa can be performed using fluorescence labeled inhibitors of caspases (FLICA™). It allows investigating caspase activation in semen samples with regard to a single cell. The FLICA™ reagent is comprised of 3 segments—it includes a green (FAM 5 carboxyfluorescein) fluorescent label; an amino acid peptide inhibitor sequence targeted by the active caspase; and a fluoromethylketone group (FMK), which acts as a leaving group and forms a covalent bond with the active enzyme. Fluorescence labeled inhibitors of caspases are cell permeable and noncytotoxic (cited by Grunewald et al., 2009). Martin et al. (2004) showed that cryopreservation of bovine spermatozoa induced the significant increase in the proportion of cells with active caspases, which were mainly detected in the intermediate piece of spermatozoa.

### 3.2.7 DNA status of spermatozoa

DNA integrity has been considered as an important parameter in the determination of spermatozoa ability to withstand the cryopreservation process. It is suggested that chromatin structure should be studied as an independent complementary parameter for the better assessment of the sperm quality (Evenson et al., 2002). The spermatozoal chromatin is much more compact when compared to somatic and spermatogenic cell types (e.g., spermatogonia, spermatocytes and spermatids). It appears that during freezing-thawing procedure the integrity of the nuclear DNA, which is related to fertility, could be negatively

affected. Although, spermatozoa with DNA damage may be able to fertilize an oocyte, that could potentially disturb (epi)genetic regulation of the early embryo and block its further development (Lewis & Aitken, 2005).

DNA damage can be evaluated at different levels. One of the usually used methods, developed for detecting changes in the chromatin structure of DNA integrity, is the sperm chromatin structure assay (SCSA) (Chohan et al., 2006). The SCSA is a flow cytometric method for identification of changes in the DNA status. It is based on the assumption that a structurally abnormal sperm chromatin shows a higher susceptibility to acid denaturation (Evenson et al., 2002). The SCSA method utilizes the metachromatic properties of acridine orange (AO). This stain fluoresces in the green band when intercalates into the intact double-stranded DNA helix, and in the red band when associated with single strand denaturated DNA and RNA. After denaturation of chromatin by decreased pH, the spermatozoa with structurally abnormal chromatin fluorescence is detected in the red band (Fig. 6f) (Bochenek et al., 2001). The fertility data have been shown to correlate with the results obtained from the SCSA of human (Evenson et al., 1980), bull (Ballachey et al., 1988; Karabinus et al., 1990), stallion (Love & Kenney, 1998) and boar semen (Evenson et al., 1994). SCSA was also used for dog semen assessment (Garcia-Macias et al., 2006) and for evaluation of freezing-thawing effect on chicken and goose DNA status (Partyka et al. 2010; Partyka et al., 2011b).

Another method to detect DNA defragmentation is TUNEL assay, which allows to incorporate of fluorescent nucleotide analogs by a terminal nucleotide transferase into single stranded DNA areas at the 3-OH termini (Chohan et al., 2006). Ramos & Wetzels (2001) using this method have shown that DNA damage is limited in functional human spermatozoa resulting from a swim-up procedure.

The alternative method for detecting the DNA damage at the level of individual cells is the single-cell DNA gel electrophoresis assay (COMET). Although this method does not use such equipment as flow cytometry, application of fluorescent DNA specific stain is required. In COMET assay spermatozoa are spread on a surface covered with an agarose gel, and treated with a solution that lyses the cell components leaving the DNA immobilized in the agarose. They are then subjected to a DNA denaturation process, followed by electrophoresis, causing DNA fragments to migrate away from the main bulk of nuclear DNA. After staining with propidium iodide or ethidium bromide, cells with DNA strand breaks, display a comet-like shape, with the undamaged DNA located in the head of the comet and the fragmented DNA dispersed through the tail. Image analyses provide information on the extent of strand breaks in the DNA molecule. Several studies, conducted with different techniques, including comet assay, showed a negative relationship between the fertilization potential of spermatozoa and alterations at the level of genetic material. In particular in humans, infertility has been associated with higher levels of DNA damage in sperm compared to fertile subjects (Irvine et al., 2000). Fraser & Strzeżek (2007) have shown that the freezing-thawing process provoked sperm chromatin destabilization rendering the boar spermatozoa more vulnerable to DNA fragmentation. COMET assay has also been recently used for the evaluation of cryopreserved avian semen (Madeddu et al., 2010; Gliozzi et al., 2011).

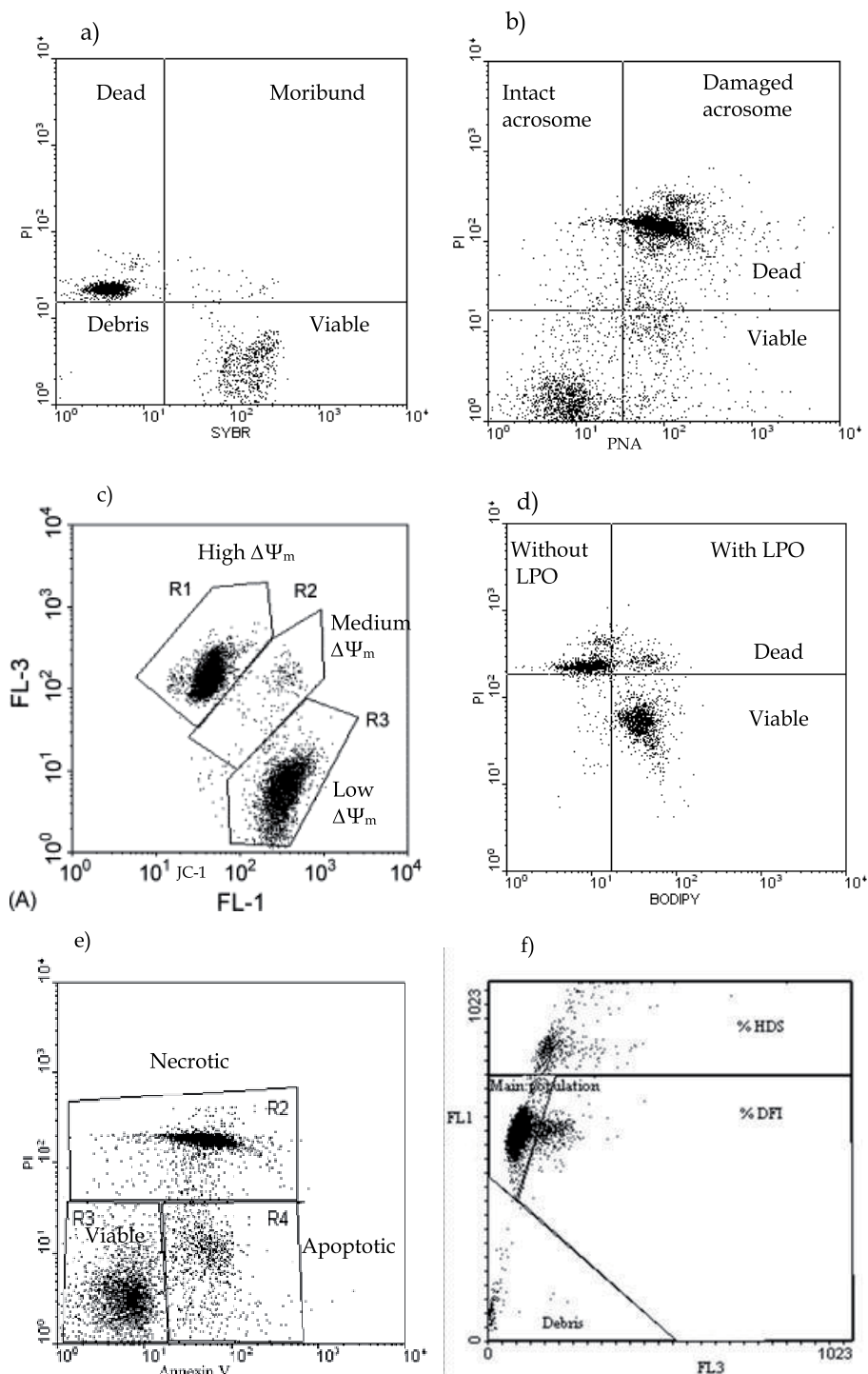

Fig. 6. Examples of flow cytometry analyses of frozen-thawed spermatozoa: a) Dot plot of SYBR-14/PI stain. Four subpopulations can be distinguished: dead sperm (red stained),

moribund sperm (red/green fluorescence), viable sperm (green stained), unstained debris are discarded; b) Dot plot of PNA-AlexaFluor/PI stain. Spermatozoa can be identified as: acrosome - intact/damaged, together with selection - viable/dead, according to their green and red fluorescence; c) Dot plot of JC-1 staining for mitochondrial status analysis. The intensity of orange fluorescence depends on mitochondrial membrane potential ( $\Delta\Psi_m$ ) allowing for differentiation between high, medium and low  $\Delta\Psi_m$ ; d) Dot plot of C<sub>11</sub>BODIPY<sup>581/591</sup>/PI for assessment of lipid peroxidation (LPO). Spermatozoa can be divided into four subpopulations: dead without LPO, dead with LPO, live without LPO and live with LPO; e) Dot plot of Annexin V/PI stain. Spermatozoa can be identified as: viable, necrotic and apoptotic; f) Dot plot of SCSA using acridine orange. The distribution of spermatozoa is based on green (FL1) and red (FL3) fluorescence. Main population includes sperm without DNA fragmentation, %DFI represents the percentage of sperm with detectable DNA fragmentation and % HDS determines the percentage of immature cells.

### 3.3 In vitro gamete interaction tests

During fertilization, a sperm initially binds to the oocyte zona pellucida (ZP), undergoes the acrosome reaction (AR), penetrates the ZP, and fuses with the oolemma to form a zygote. Sperm-ZP interactions are carbohydrate-mediated events in various species, including humans (Benoff, 1997). The ZP of mammalian oocytes is a critical site for sperm-oocyte interaction. The ability of sperm to bind to the ZP indicates many functions of spermatozoa, such as viability, motility, morphology, acrosomal status and the ability to penetrate the oocyte (Liu & Baker, 1994), and for that reason this ability is of a diagnostic relevance.

#### 3.3.1 Zona pellucida binding assay

The assessment of the ability of sperm cells to bind the homologous zona pellucida (ZP) is the useful test for prediction of spermatozoal fertilizing ability (Hermansson et al., 2006). It is assumed that it is reliable test to detect sperm damage at a molecular level, which is not visible by microscopic analysis, because binding is receptor-ligand mediated reaction. The test may be done in two ways: by using intact homologous oocytes (ZP-binding assay, ZBA) and by using bisected hemizonae (hemizona binding assay, HZA) (Kawakami et al., 1998; Rijsselaere et al., 2005). In ZBA spermatozoa are coincubated with oocytes obtained from sliced ovaries. The number of spermatozoa that bound to ZP is counted with contrast-phase microscopy. The disadvantage of ZBA is the fact that the attachment of sperm cells to zona depends on the oocyte. This feature was partly overcome in HZA. Bisected by micromanipulation two parts of ZP are coincubated with spermatozoa. As a result the direct comparison of sperm cells from two origins may be done (Ivanova et al., 1999; Mayenco-Aguirre & Pérez Cortés, 1998).

A sublethal damage that occurs during cryopreservation leads to loss of sperm surface proteins, segregation of membrane proteins, inactivation of membrane-bound enzymes and decreased lateral protein diffusion within the membrane (Watson, 1995). Kadirvel et al. (2011) observed significant reduction of the zona binding ability of cryocapacitated buffalo bulls spermatozoa, and further reduction of binding ability of frozen-thawed spermatozoa, after incubation, in either capacitating, or non capacitating medium. Similar results have been obtained in bulls (Fazeli et al., 1997) and humans (Amann et al., 1999) spermatozoa, with significantly reduced binding ability to the zona pellucida after freezing and thawing.

The reduced binding ability of the frozen-thawed spermatozoa might be due to the higher proportion of acrosome reacted and damaged spermatozoa, after cryopreservation and thawing. Moreover, impaired receptor-ligand interaction in frozen-thawed spermatozoa could be caused by cryoelution of an "essential ligand" from the sperm surface that has been described in human (Amann et al., 1999).

### 3.3.2 Oocyte penetration assay

Oocyte penetration assays (OPT) involve multiple sperm penetrations of each oocyte and permit the observation of pronuclear development (Yanagimachi et al., 1976). The application of the zona-free hamster oocyte assay has been used to assess the fertility of men (Freeman et al., 2001; ) and domestic animals (Cormier et al., 1997; De los Reyes et al., 2009; Hewitt & England, 1997; Maxwell et al., 1996;). The OPT is a less time-consuming technique than *in vitro* fertilization (IVF) test, because oocytes can be immatured, and after evaluation are not further subjected to development. In this assay spermatozoa presented in the perivitelline space and ooplasm of the oocytes are observed under fluorescent microscopy using Hoechst 33258, PI or light microscopy (aceto-orcein) (Hay et al., 1997; Hewitt & England, 1997).

All changes in cryopreserved spermatozoa described in the above sections may affect the final percentage of fertilized oocytes, and also the time course of sperm penetration through the oocyte envelop, as reported previously in frozen-thawed ram and bovine sperm (Cormier et al., 1997; Maxwell et al., 1996). Nevertheless, the previous study has indicated that the major ability of cryopreserved sperm to penetrate oocytes occurs at the 1st hour of co-culture (Cormier et al., 1997; De los Reyes et al., 2009). This finding indicates that these sperm can undergo the events associated with fertilization earlier or faster than fresh sperm in relation with cryocapacitation appearance.

Because the efficiency of oocyte penetration is a result of sperm-oocyte interaction, variation in oocyte properties are likely to produce large diversity in this assay results. However, this can be reduced with the use of a large number of oocytes (Lucas et al., 2003). However, in dogs *in vitro* maturation (IVM) of oocytes and IVF is difficult to achieve. Nevertheless capacitated dog spermatozoa are able to penetrate immature oocytes, inducing chromatin decondensation and resumption of meiosis (Luvoni et al., 2005; Hay et al., 1994; Sain-Dizier et al., 2001). Thus, in dogs both, immature or mature oocytes, may be use for this test.

## 4. Conclusions

For many years, scientists have made every endeavour to develop laboratory assays that precisely estimate the fertilizing capacity of semen. Laboratory semen appraisals can be classified in several ways. Nevertheless, an important factor for a laboratory analysis to be useful, it must be objective, repeatable, accurate and as far as possible, rapid. Among others, there can be distinguished one major division into conventional methods and advanced techniques of sperm assessment. It is little questionable, whether the subjective assessment of parameters related to the functional and morphological characteristics of spermatozoa, would increase the predictability of the fertilizing potential of cryopreserved semen. However, conventional methods for sperm evaluation in connection with the more objective computer-assisted sperm analyzers, flow cytometry and *in vitro* fertilization tests, have



enabled researchers to gain accurate information about the morpho-functional status of spermatozoa and mechanisms of sperm cryoinjury.

## 5. Acknowledgments

This work was supported by the Polish National Science Centre, grant no N N311 530040.

## 6. References

- Agarwal, A.; Ozturk E. & Loughlin, K.R. (1992). Comparison of semen analysis between the two Hamilton-Thorn semen analysers. *Andrologia* 24, 327-329.
- Agarwal, A.; Prabakaran, S.A. & Said T.M. (2005). Prevention of oxidative stress injury to sperm. *J Androl* 26, 654-60.
- Aitken, R.J. (1995). Free radicals, lipid peroxidation and sperm function. *Reprod Fertil Dev* 7, 659-668.
- Aitken, R.J.; Harikss, D. & Buckingham, DW. (1993). Analysis of lipid peroxidation mechanisms in human spermatozoa. *Mol Reprod Dev* 35, 302-315.
- Aitken, R.J.; Wingate, J.K.; De Iuliis, G.N. & McLaughlin, E.A. (2007). Analysis of lipid peroxidation in human spermatozoa using BODIPY C11. *Mol Hum Reprod* 13, 203-211.
- Almeida, J. & Ball, B.A. (2005). Effect of  $\alpha$ -tocopherol and tocopherol succinate on lipid peroxidation in equine spermatozoa. *Anim Reprod Sci* 87, 321-337.
- Álvarez, M.; García-Macías, V.; Martínez-Pastor, F.; Martínez, F.; Borragán, S.; Mata, M.; Garde, J.; Anel, L. & De Paz, P. (2008). Effects of cryopreservation on head morphometry and its relation with chromatin status in brown bear (*Ursus arctos*) spermatozoa. *Theriogenology* 70, 1498-1506.
- Amann, R.P. (1999). Cryopreservation of sperm. In: *Encyclopedia of Reproduction*, vol. 1. Academic Press, Burlington, MA, USA, 773-783.
- Amann, R.P.; Shabanowitz, R.B.; Huszar, G. & Broder, S.J. (1999). In vitro sperm-binding assay to distinguish differences in populations of human sperm or damage to sperm resulting from cryopreservation. *J Androl* 20, 648-654.
- Arruda, R.P.; Ball, B.A.; Gravance, C.G.; Garcia, A.R. & Liu IKM. (2002). Effects of extender and cryoprotectants on stallion sperm head morphometry. *Theriogenology* 58, 253-6.
- Bailey, J.L. & Buhr, M.M. (1994). Cryopreservation alters the Ca<sup>2+</sup> flux of bovine spermatozoa. *Can J Anim Sci* 74, 45-52.
- Bailey, J.L., Bilodeau J.F. & Cormier, N. (2000). Semen cryopreservation in domestic animals: a damaging and capacitating phenomenon. *J Androl* 21, 1-7.
- Ballachey, B.E.; Evenson, D.P. & Saacke, R.G. (1988). The sperm chromatin structure assay. Relationship with alternate tests of semen quality and heterospermic performance of bulls. *J Androl* 9, 109-115.
- Benoff, S. (1997). Carbohydrates and fertilization: an overview. *Mol Hum Reprod* 3, 599-637.
- Bilodeau, J-F., Chatterjee, S.; Sirard, M-A. & Gagnon, C. (2000). Levels of antioxidant defences are decreased in bovine spermatozoa after a cycle of freezing and thawing. *Mol Reprod Dev* 55, 282-288.
- Blesbois, E.; Grasseau, I.; Seigneurin, F.; Mignon-Grasteau, S.; Saint Jalme, M. & Mialon-Richard, M.M. (2008). Predictors of success of semen cryopreservation in chickens. *Theriogenology* 69, 252-261.

- Blom, E. (1950). Interpretation of spermatic cytology in bulls. *Fertil Steril* 1, 223-38.
- Blom, E. (1968). A new sperm defect—"Pseudodroplets"—in the middle piece of the bull sperm. *Nord Vet Med* 20, 279-283.
- Blom, E. (1983). Pathological conditions in the genital organs and in the semen as ground for rejection of breeding bulls for import or export to and from Denmark, 1958-1982. *Nord Vet Med* 35, 105-130.
- Bochenek, M.; Smorağ, Z. & Pilch, J. (2001). Sperm chromatin structure assay of bulls qualified for artificial insemination. *Theriogenology* 56, 557-567.
- Bratton, D.L.; Fadok, V.A.; Richter, D.A.; Kailey, J.M.; Guthrie, L.A. & Henson, P.M. (1997). Appearance of phosphatidylserine on apoptotic cells requires calcium-mediated nonspecific flip-flop and is enhanced by loss of the aminophospholipid translocase. *J Biol Chem* 272, 26159-26165.
- Brito, L.F.; Barth, A.D.; Bilodeau-Goeseels, S.; Panich, P.L. & Kastelic, J.P. (2003). Comparison of methods to evaluate the plasmalemma of bovine sperm and their relationship with in vitro fertilization rate. *Theriogenology* 60, 1539-1551.
- Brito, L.F.; Greene, L.M.; Kelleman, A.; Knobbe, M. & Turner, R. (2011). Effect of method and clinician on stallion sperm morphology evaluation. *Theriogenology* 76, 745-750.
- Brouwers, J.F.H.M. & Gadella, B.M. (2003). In situ detection and localization of lipid peroxidation in individual bovine sperm cells. *Free Radical Biol Med* 35, 1382-1391.
- Brouwers, J.F.H.M.; Silva, P.F.N. & Gadella, B.M. (2005). New assay for detection and localization of endogenous lipid peroxidation products in living boar sperm after BTS dilution or after freeze-thawing. *Theriogenology* 63, 458-469.
- Chatterjee, S. & Gagnon, C. (2001). Reproduction of reactive oxygen species by spermatozoa undergoing cooling, freezing, and thawing. *Mol Reprod Dev* 59, 451-458.
- Chohan, K.R.; Griffin, J.T.; Lafromboise, M. & De Jonge, C.J. (2006). Comparison of chromatin assays for DNA fragmentation evaluation in human sperm. *J Androl* 27, 53-59.
- Christensen, P.; Stenvang, J.P. & Godfrey, W.L. (2004). A flow cytometric method for rapid determination of sperm concentration and viability in mammalian and avian semen. *J Androl* 25, 255-264.
- Coetzee, K.; Kruger, T.F.; Lombard, C.J.; Shaughnessy, D.; Oehninge, S.; Ozgür, K.; Pomeroy, K.O. & Muller C.H. (1999). Assessment of interlaboratory and intralaboratory sperm morphology readings with the use of a Hamilton Thorne Research integrated visual optical system semen analyzer. *Fertil Steril* 71, 80-84.
- Colenbrander, B.; Gadella, B. & Stout, T. (2003). The Predictive Value of Semen Analysis in the Evaluation of Stallion Fertility. *Reprod Domest Anim* 38, 305-311.
- Cormier, N. & Bailey J.L. (2003). A differential mechanism is involved during heparin-and cryopreservation-induced capacitation. *Biol Reprod* 69, 177-185.
- Cormier, N.; Sirard, M.A. & Bailey, J. (1997). Premature capacitation of bovine spermatozoa is initiated by cryopreservation. *J Androl* 18, 457-461.
- Correa, J.R. & Zavos, P.M. (1994). The hypoosmotic swelling test: its employment as an assay to evaluate the functional integrity of the frozen-thawed bovine sperm membrane. *Theriogenology* 42, 351-360.
- Davis, R.O. & Katz D.F. (1992). Standardization and comparability of CASA instruments. *J Androl* 13, 81-86.

- De los Reyes, M.; Palomino J.; de Lange, J.; Anguita, C. & Barros, C. (2009). In vitro sperm penetration through the zona pellucida of immature and in vitro matured oocytes using fresh, chilled and frozen canine semen. *Anim Reprod Sci* 110, 37–45.
- Desagher, S. & Martinou, J.C. (2000). Mitochondria as the central control point of apoptosis. *Trends Cell Biol* 10, 369–77.
- Didion, B.A.; Dobrinsky, J.R.; Giles, J.R. & Graves, C.N. (1989). Staining procedure to detect viability and the true acrosome reaction in spermatozoa of various species. *Gamete Res* 22, 51–57.
- Dobrinski, I.; Smith, T.T.; Suarez, S.S. & Ball, A.B. (1997). Membrane contact with oviductal epithelium modulates the intracellular calcium concentration of equine spermatozoa in vitro. *Biol. Reprod* 56, 861–869.
- Donoghue, A.M.; Garner, D.L.; Donoghue, D.J. & Johnson, L.A. (1995). Viability assessment of turkey sperm using fluorescent staining and flow cytometry. *Poult Sci* 74, 1191–1200.
- Drummen, G.P.; Van Liebergen, L.C.M.; Op Den Kamp, J.A.F. & Post, J.A. (2002). C11-BODIPY581/591, an oxidation-sensitive fluorescent lipid peroxidation probe: (micro)spectroscopic characterization and validation of methodology. *Free Radical Biol Med* 33, 473–490.
- Esteso, M.C.; Fernandez-Santos, M.R.; Soler, A.J. & Garde, J.J. (2003). Head dimensions of cryopreserved red deer spermatozoa are affected by thawing procedure. *Cryo Letters* 24, 261–268.
- Esteves, S.C.; Sharma, R.K.; Thomas, A.J. & Agarwal, T.A. (2007). Evaluation of acrosomal status and sperm viability in fresh and cryopreserved specimens by the use of fluorescent Peanut agglutinin lectin in conjunction with hypo-osmotic swelling test. *Int Braz J Urol* 33, 364–376.
- Evenson, D.P.; Darzynkiewicz, Z. & Melamed, M.R. (1980). Relation of mammalian sperm chromatin heterogeneity to fertility. *Science* 210, 1131–1133.
- Evenson, D.P.; Larson, K.L. & Jost, L.K. (2002). Sperm chromatin structure assay: its clinical use for detecting sperm DNA fragmentation in male infertility and comparisons with other techniques. *J Androl* 23, 25–43.
- Evenson, D.P.; Thompson, L. & Jost, L. (1994). Flow cytometric evaluation of boar semen by the sperm chromatin structure assay as related to cryopreservation and fertility. *Theriogenology* 41, 637–651.
- Fazeli, A.R.; Zhang, B.R.; Steenweg, W.; Larsson, B.; Bevers, M.M.; van den Broek, J.; Rodriguez-Martinez, H. & Colenbrander, B. (1997). Relationship between sperm-zona pellucida binding assay and the 56-day nonreturn rate of cattle inseminated with frozen-thawed semen. *Theriogenology* 48, 853–863.
- Fraser, L.R.; Abeydeera, L.R. & Niwa, K. (1995). Ca<sup>2+</sup>-regulating mechanisms that modulate bull sperm capacitation and acrosome exocytosis as determined by chlortetracycline analysis. *Mol Reprod Dev* 40, 233–241.
- Fraser, L. & Strzeżek J. (2007). Is there a relationship between the chromatin status and DNA fragmentation of boar spermatozoa following freezing-thawing? *Theriogenology* 68, 248–257.
- Freeman, M.R.; Archibong, A.E.; James, J.; Mrotek, C.M.; Whitworth, G.A. & Weitzman, G.A. (2001). Hill. Male partner screening before in vitro fertilization: preselecting

- patients who require intracytoplasmic sperm injection with the sperm penetration. *Fertil Steril* 76, 1113-1118.
- Freneau, G.E.; Chenoweth, P.J.; Ellis, R. & Rupp, G. (2010). Sperm morphology of beef bulls evaluated by two different methods. *Anim Reprod Sci* 118, 176-181.
- Gadella, B.M.; Miller, N.G.; Colenbrander, B.; van Golde, L.M. & Harrison, R.A. (1999). Flow cytometric detection of transbilayer movement of fluorescent phospholipid analogues across the boar sperm plasma membrane: elimination of labeling artifacts. *Mol Reprod Dev* 53, 108-125.
- Gadella, B.M. & Harrison, R.A. (2002). Capacitation induces cyclic adenosine 3',5'-monophosphate-dependent, but apoptosis-unrelated, exposure of aminophospholipids at the apical head plasma membrane of boar sperm cells. *Biol Reprod* 67, 340-350.
- Garcia-Macias, V.; Martinez-Pastor, F.; Alvarez, M.; Garde, J.J.; Anel, E.; Anel, L. & de Paz, P. (2006). Assessment of chromatin status (SCSA®) in epididymal and ejaculated sperm in Iberian red deer, ram and domestic dog. *Theriogenology* 66, 1921-1930.
- Garner, D.L. & Thomas, C.A. (1999). Organelle-specific probe JC-1 identifies membrane potential differences in the mitochondrial function of bovine sperm. *Mol Reprod Dev* 53, 222-229.
- Garner, D.L. & Johnson L.A. (1995). Viability assessment of mammalian sperm using SYBR-14 and Propidium Iodide. *Biol Reprod* 53, 276-284.
- Garner, D.L.; Thomas, C.A.; Joerg, H.W.; DeJarnette, J.M. & Marshall, C.E. (1997). Fluorometric assessments of mitochondrial function and viability in cryopreserved bovine spermatozoa. *Biol Reprod* 57, 1401-1406.
- Glander, H.J. & Schaller, J. (1999). Binding of annexin V to plasma membranes of human spermatozoa: a rapid assay for detection of membrane changes after cryostorage. *Mol Hum Reprod* 5, 109-115.
- Gliozzi, T.M.; Zaniboni, L. & Cerolini, S. (2011). DNA fragmentation in chicken spermatozoa during cryopreservation. *Theriogenology* 75, 1613-1622.
- Graham, J.K. (2001). Assessment of sperm quality: a flow cytometric approach. *Anim Reprod Sci* 68, 239-247.
- Graham, J.K.; Kunze, E. & Hammerstedt, R.H. (1990). Analysis of sperm cell viability, acrosomal integrity, and mitochondrial function using flow cytometry. *Biol Reprod* 43, 55-64.
- Gravance, C.G.; Garner, D.L.; Miller, M.G. & Berger, T. (2001). Fluorescent probes and flow cytometry to assess rat sperm integrity and mitochondrial function. *Reprod Toxicol* 15, 5-10.
- Gravance, C.G.; Garner, D.L.; Baumber, J. & Ball, B.A. (2000). Assessment of equine sperm mitochondrial function using JC-1. *Theriogenology* 53, 1691-1703.
- Gravance, C.G.; Vishwanath, R.; Pitt, C.; Garner, D.L. & Casey, P.J. (1998). Effects of cryopreservation on bull sperm head morphometry. *J Androl* 19, 704-709.
- Green, C.E. & Watson, P.F. (2001). Comparison of the capacitation-like state of cooled boar spermatozoa with true capacitation. *Reproduction* 122, 889-898.
- Grunewald, S.; Sharma, R.; Paasch, U.; Glander, H.J. & Agarwal, A. (2009). Impact of Caspase Activation in Human Spermatozoa. *Micros Res Techniq* 72, 878-888.

- Guérin, P. ; Ferrer, M. ; Fontbonne, A. ; Bénigni, L. ; Jacquet, M. & Ménézo, Y. (1999). In vitro capacitation of dog spermatozoa as assessed by chlortetracycline staining. *Theriogenology* 52, 617-628.
- Guthrie, H.D. & Welch, G.R. (2007). Use of fluorescence-activated flow cytometry to determine membrane lipid peroxidation during hypothermic liquid storage and freeze-thawing of viable boar sperm loaded with 4,4-difluoro-5-(4-phenyl-1,3-butadienyl)-4-bora-3a,4a-diaza-s-indacene-3-undecanoic acid. *J Anim Sci* 85, 1402-1411.
- Halliwell, B. & Chirico S. (1993). Lipid peroxidation: its mechanism, measurement and significance. *Am J Clin Nutr* 57, 715-725.
- Hammerstedt, R.H.; Graham, J.K. & Nolan, J.P. (1990). Cryopreservation of mammalian sperm: what we ask them to survive. *J Androl* 11, 73-88.
- Hay, M.A.; King, W.A.; Gartley, C.J. & Goodrowe, K.L. (1994). Influence of spermatozoa on in vitro nuclear maturation of canine ova. *Biol Reprod* 50, 362.
- Hay, M.A.; King, W.A.; Gartley, C.J.; Leibo, S.P. & Goodrowe, K.L. (1997). Effects of cooling, freezing and glycerol on penetration of oocytes by spermatozoa in dogs. *J Reprod Fertil* (Suppl. 51), 99-108.
- Hermansson, U.; Ponglowhapan, S.; Linde-Forsberg, C. & Ström-Holst, B. (2006). A short sperm-oocyte incubation time ZBA in the dog. *Theriogenology* 66, 717-725.
- Hewitt, D.A. & England, G.C. (1998). An investigation of capacitation and the acrosome reaction in dog spermatozoa using a dual fluorescent staining technique. *Anim Reprod Sci* 51, 321-332.
- Hewitt, D.A. & England, G.C.W. (1997). The canine oocyte penetration assay; its use as an indicator of dog spermatozoa performance in vitro. *Anim Reprod Sci* 50, 123-139.
- Hidalgo, M.; Rodriguez, I. & Dorado, J.M. (2006). The effect of cryopreservation on sperm head morphometry in Florida male goat related to sperm freezability. *Anim Reprod Sci* 100, 61-72.
- Holden, C.A.; Hyne, R.V.; Sathananthan, A.H. & Trounson, A.O. (1990). Assessment of the human sperm acrosome reaction using concanavalin A lectin. *Mol Reprod Dev* 25, 247-257.
- Holt, W.V. (2000). Fundamental aspects of sperm cryobiology: the importance of species and individual differences. *Theriogenology* 53, 47-58.
- Howarth, B.Jr. (1970). An examination for sperm capacitation in the fowl. *Biol Reprod* 3 338-341.
- Iguer-Ouada, M. & Verstegen J. P. (2001). Validation of the Sperm Quality Analyzer (SQA) for dog sperm analysis. *Theriogenology* 55, 1143-1158.
- Irvine, D.S.; Twigg, J.P.; Gordon, E.L.; Fulton, N.; Milne, P.A. & Aitken, R.J. (2000). DNA integrity in human spermatozoa: relationships with semen quality. *J Androl* 21, 33-44.
- Ivanova, M.; Mollova, M.; Ivanova-Kicheva, M.G.; Petrov, M.; Djarkova, T. & Somlev, B. (1999). Effect of cryopreservation of zona-binding capacity of canine spermatozoa in vitro. *Theriogenology* 52, 163-170.
- Jeyendran, R.S.; van der Venn, H.H. & Zaneveld, L.J.D. (1992). The hypoosmotic swelling test: an update. *Arch Androl* 29, 105-116.
- Jones, R. & Mann, T. (1977). Damage to ram spermatozoa by peroxidation of endogenous phospholipids. *J Reprod Fert* 50, 261-268.

- Kadirvel, G., Kathiravan, P. & Kumar, S. (2011). Protein tyrosine phosphorylation and zona binding ability of in vitro capacitated and cryopreserved buffalo spermatozoa. *Theriogenology* 75, 1630-1639.
- Karabinus, D.S.; Evenson, D.P.; Jost, L.K.; Baer, R.K. & Kaproth, M.T. (1990). Comparison of semen quality in young and mature Holstein bulls measured by light microscopy and flow cytometry. *J Dairy Sci* 73, 2364-2371.
- Katkov, I.I. & Lulat, A.G-M.I. (2000). Do conventional CASA-parameters reflect recovery of kinematics after freezing?: "CASA paradox" in the analysis of recovery of spermatozoa after cryopreservation. *CryoLetters* 21, 141-148.
- Kawakami, E.; Kashiwagi, C.; Hori, T. & Tsutsui, T. (2001). Effects of canine oviduct epithelial cells on movement and capacitation of homologous spermatozoa in vitro. *Anim Reprod Sci* 68, 121-131.
- Kawakami, E.; Morita, Y.; Hori, T. & Tsutsui, T. (2002). Lectin-binding characteristics and capacitation of canine epididymal spermatozoa. *J Vet Med Sci* 64, 543-549.
- Kawakami, E.; Hori, T. & Tsutsui, T. (1998). Changes in semen quality and in vitro sperm capacitation during various frequencies of semen collection in dogs with both asthenozoospermia and teratozoospermia. *J Vet Med Sci* 60, 607-614.
- Kawakami, E.; Vandervoort, C.A.; Mahi-Brown, C.A. & Overstreet, J.W. (1993). Induction of acrosome reactions of canine sperm by homologous zona pellucida. *Biol Reprod* 48, 841-845.
- Kim, S-H., Yu D-H. & Kim Y-J. (2010). Effects of cryopreservation on phosphatidylserine translocation, intracellular hydrogen peroxide, and DNA integrity in canine sperm. *Theriogenology* 73, 282-292.
- Kumi-Diaka, J. (1993). Subjecting canine semen to the hypo-osmotic test. *Theriogenology* 39, 1279-1289.
- Lemoine, M.; Grasseau, I.; Brillard, J.P. & Blesbois, E. (2008). A reappraisal of the factors involved in in vitro initiation of the acrosome reaction in chicken spermatozoa. *Reproduction* 136, 391-399.
- Lewis, S.E. & Aitken, R.J. (2005). DNA damage to spermatozoa has impacts on fertilization and pregnancy. *Cell Tissue Res* 322, 33-41.
- Liu, D.Y. & Baker, H.W.G. (1994). A new test for the assessment of sperm-zona pellucida penetration: relationship with results of other sperm tests and fertilization in vitro. *Hum Reprod* 3, 489-496.
- Love, C.C. & Kenney, R.M. (1998). The relationship of increased susceptibility of sperm DNA to denaturation and fertility in the stallion. *Theriogenology*, 50, 955-972.
- Lucas, X.; Martínez, E.A.; Roca, J.; Vázquez, J.M.; Gil, M.A.; Pastor, L.M. & Alabart, J.L. (2003). Influence of follicle size on the penetrability of immature pig oocytes for homologous in vitro penetration assay. *Theriogenology* 60, 659-667.
- Łukaszewicz, E.; Jerysz, A.; Partyka, A. & Siudzińska, A. (2008). Efficacy of evaluation of rooster sperm morphology using different staining methods. *Res Vet Sci* 85, 583-688.
- Luvoni, G.C.; Chigioni, S.; Allievi, E. & Macis, D. (2005). Factors involved in vivo and in vitro maturation of canine oocytes. *Theriogenology* 63, 41-59.
- Madeddu, M.; Berlinguer, F.; Pasciu, V.; Succu, S.; Satta, V.; Leoni, G.G.; Zinellu, A.; Muzzeddu, M.; Carru, C. & Naitana, S. (2010). Differences in semen freezability

- and intracellular ATP content between the rooster (*Gallus gallus domesticus*) and the Barbary partridge (*Alectoris barbara*). *Theriogenology* 74, 1010–1018.
- Maree, L.; du Plessis, S.S.; Menkveld, R. & van der Horst, G. (2010). Morphometric dimensions of the human sperm head depend on the staining method used. *Hum Reprod* 25, 1369–1382.
- Martin, G.; Sabido, O.; Durand, P. & Levy, R. (2004). Cryopreservation induces an apoptosis like mechanism in bull sperm. *Biol Reprod* 71, 28–37.
- Martin, S.J.; Reutelingsperger, C.P.; McGahon, A.J.; Rader, J.A.; van Schie, R.C.; LaFace, D.M. & Green, D.R. (1995). Early redistribution of plasma membrane phosphatidylserine is a general feature of apoptosis regardless of the initiating stimulus: inhibition by overexpression of Bcl-2 and Abl. *J Exp Med* 182, 1545–1556.
- Maxwell, W.C.; Catt, S.L. & Evans, G. (1996). Dose of fresh and frozen-thawed spermatozoa for in vitro fertilization of sheep oocytes. *Theriogenology* 45, 261.
- Maxwell, W.M. & Johnson, L.A. (1997). Chlorotetracycline analysis of boar spermatozoa after incubation, flow cytometric sorting, cooling, or cryopreservation. *Mol Reprod Dev* 46, 408–418.
- Mayenco-Aguirre, A.M. & Pérez Cortés, A.B. (1998). Preliminary results of hemizona assay (HZA) as a fertility test for canine spermatozoa. *Theriogenology* 50, 195–204.
- Meyers S.A., Yudir A.I., Cherr G.N., VandeVoort C.A., Myles D.G., Primakoff P. & Overstreet J.W., (1997) Hyaluronidase activity of macaque sperm assessed by in vitro cumulus penetration assay. *Mol Reprod Dev* 46, 392–400.
- Nagy, S.; Hallap, T.; Johannisson, A. & Rodriguez-Martinez, H. (2004). Changes in plasma membrane and acrosome integrity of frozen-thawed bovine spermatozoa during a 4h incubation as measured by multicolor flow cytometry. *Anim Reprod Sci* 80, 225–235.
- Neild, D.; Chaves, G.; Flores, M.; Mora, N.; Beconi, M. & Agüero, A. (1999). Hypoosmotic test in equine spermatozoa. *Theriogenology* 51, 721–727.
- Neild, D.M.; Brouwers, J.F.H.M.; Colenbrander, B.; Aguero, A. & Gadella, B.M. (2005). Lipid peroxide formation in relation to membrane stability of fresh and frozen thawed stallion spermatozoa. *Mol Reprod Dev* 72, 230–238.
- Niżański, W.; Klimowicz, M.; Partyka, A.; Savić, M. & Dubiel, A. (2009). Effects of the inclusion of Equex STM into Tris-based extender on the motility of dog spermatozoa incubated at 5 degrees C. *Reprod Domest Anim* 44, (Suppl. 2), 363–365.
- Ortega Ferrusola, C.; Sotillo Galán, Y.; Varela Fernández, E.; Gallardo Bolaños, J.M.; González Fernández, L.; Tapia, J.A. & Peña, F.J. (2008). Detection of apoptosis like changes during the cryopreservation process in equine sperm. *J Androl* 29, 213–221.
- Ortega-Ferrusola, C.; Macías García, B.; Gallardo-Bolaños, J.M.; González-Fernández, L.; Rodríguez-Martinez, H.; Tapia, J.A. & Peña, F.J. (2009). Apoptotic markers can be used to forecast the freezeability of stallion spermatozoa. *Anim Reprod Sci* 114, 393–403.
- Parks, J.E. & Graham, J.K. (1992). Effects of cryopreservation procedures on sperm membranes. *Theriogenology* 38, 209–222.
- Partyka, A.; Jerysz, A. & Pokorný, P. (2007). Lipid peroxidation in fresh and stored semen of Green-legged Partridge. *E.J.P.A.U.* 10, (2),  
<http://www.ejpau.media.pl/volume10/issue2/art-08.html>

- Partyka, A.; Łukaszewicz, E. & Nizański, W. (2011a). Flow cytometric assessment of fresh and frozen-thawed Canada goose (*Branta canadensis*) semen. *Theriogenology* 76, 843–850.
- Partyka, A.; Łukaszewicz, E.; Nizański, W. & Twardoń, J. (2011b). Detection of lipid peroxidation in frozen-thawed avian spermatozoa using C11-BODIPY581/591. *Theriogenology* 75, 1623–1629.
- Partyka, A.; Nizański, W. & Łukaszewicz, E. (2010). Evaluation of fresh and frozen-thawed fowl semen by flow cytometry. *Theriogenology* 74, 1019–1027.
- Peña Martínez, A.I. (2004). Canine fresh and cryopreserved semen evaluation. *Anim Reprod Sci* 82–83, 209–224.
- Peña, A.I.; Johannisson, A. & Linde-Forsberg, C. (2001). Validation of flow cytometry for assessment of viability and acrosomal integrity of dog spermatozoa and for evaluation of different methods of cryopreservation. *J Reprod Fertil* (Suppl. 57), 371–376.
- Peña, A.I.; Quintela, L.A. & Herradón, P.G. (1998). Viability assessment of dog spermatozoa using flow cytometry. *Theriogenology* 50, 1211–1220.
- Pena, F.J.; Johannisson, A.; Wallgren, M. & Rodriguez-Martinez, H. (2003). Assessment of fresh and frozen-thawed boar semen using an Annexin-V assay: a new method of evaluating sperm membrane integrity. *Theriogenology* 60, 677–689.
- Pérez-Llano, B.; Lorenzo, J.L.; Yenes, P.; Trejo, A. & Garcia-Casado, P. (2001). A short hypoosmotic swelling test for the prediction of boar sperm fertility. *Theriogenology* 56, 387–398.
- Petrunkina, A.M.; Simon, K.; Günzel-Apel, A.R. & Töpfer-Petersen, E. (2003). Regulation of capacitation of canine spermatozoa during co-culture with heterologous oviductal epithelial cells. *Reprod Domest Anim* 38, 455–463.
- Petrunkina, A.M.; Simon, K.; Günzel-Apel, A.R. & Töpfer-Petersen, E. (2004). Kinetics of protein tyrosine phosphorylation in sperm selected by binding to homologous and heterologous oviductal explants: how specific is the regulation by the oviduct? *Theriogenology* 61, 1617–1634.
- Ramos, L. & Wetzels, A.M. (2001). Low rates of DNA fragmentation in selected motile human spermatozoa assessed by the TUNEL assay. *Hum Reprod* 16, 703–707.
- Rathi, R.; Colenbrander, B.; Bevers, M.M. & Gadella, B.M. (2001). Evaluation of in vitro capacitation of stallion spermatozoa. *Biol Reprod* 65, 462–470.
- Rijsselaere, T.; Van Soom, A.; Hoflack, G.; Maes, D. & de Kruif, A. (2004). Automated sperm morphometry and morphology analysis of canine semen by the Hamilton-Thorne analyser. *Theriogenology* 62, 1292–1306.
- Rijsselaere, T.; van Soom, A.; Maes, D. & de Kruif, A. (2003). Effect of technical settings on canine semen motility parameters measured by the Hamilton-Thorne analyzer. *Theriogenology* 60, 1553–1568.
- Rijsselaere, T.; Van Soom, A.; Tanghe, S.; Coryn, M.; Maes, D. & de Kruif, A. (2005). New techniques for the assessment of canine semen quality: A review. *Theriogenology* 64, 706–719.
- Rodríguez-Gil, J.E.; Montserrat, A. & Rigau, T. (1994). Effects of hypoosmotic incubation on acrosome and tail structure on canine spermatozoa. *Theriogenology* 42, 815–829.
- Rota, A.; Peña, A.I.; Linde-Forsberg, C. & Rodriguez-Martinez, H. (1999). In vitro capacitation of fresh, chilled and frozen-thawed dog spermatozoa assessed by the



- chlortetracycline assay and changes in motility patterns. *Anim Reprod Sci* 57, 199-215.
- Rubio-Guillén, J.; González, D.; Garde, J.J.; Estes, M.C.; Fernández-Santos, M.R.; Rodríguez-Gil, J.E.; Madrid-Bury, N. & Quintero-Moreno, A. (2007). Effects of cryopreservation on bull spermatozoa distribution in morphometrically distinct subpopulations. *Reprod Domest Anim* 42, 354-357.
- Saint-Dizier, M.; Salomon J.F.; Petit C.; Renard J.P. & Chastant-Maillard S. (2001). In vitro maturation of bitch oocytes: effect of sperm penetration. *J Reprod Fertil (Suppl. 57)*, 147-150.
- Santiago-Moreno, J.; Castano, C.; Coloma, M.A.; Gomez-Brunet, A.; Toledano-Diaz, A.; Lopez-Sebastian, A. & Campo, J.L. (2009). Use of the hypo-osmotic swelling test and aniline blue staining to improve the evaluation of seasonal sperm variation in native Spanish free-range poultry. *Poult Sci* 88, 2661-2669.
- Silva, P.F. & Gadella, B.M. (2006). Detection of damage in mammalian sperm cells. *Theriogenology* 65, 958-978.
- Sirivaidyapong, S., Cheng F.P., Marks A., Voorhout W.F., Bevers M.M. & Colenbrander B. (2000). Effect of sperm diluents on the acrosome reaction in canine sperm. *Theriogenology* 53, 789-802.
- Sprecher, D.J. & Coe, P.H. (1996). Differences in bull spermograms using eosin-nigrosin stain, feulgen stain, and phase contrast microscopy methods. *Theriogenology* 45, 757-764.
- Suarez S.S., Katz D.F. & Overstreet J.W. (1983). Movement characteristics and acrosomal status of rabbit spermatozoa recovered at the site and time of fertilization. *Biol Reprod* 29, 1277-87.
- Szász, F.; Sirivaidyapong, S.; Cheng, F.P.; Voorhout, W.F.; Marks, A.; Colenbrander, B.; Solti, A.L. & Gadella, B.M. (2000). Detection of calcium ionophore induced membrane changes in dog sperm as a simple method to predict the cryopreservability of dog semen. *Mol Reprod Dev* 55, 289-298.
- Talbot, P. & Chacon, R.S. (1981). A triple-stain technique for evaluating normal acrosome reactions of human sperm. *J Exp Zool* 215, 201-208.
- Thuwanut, P.; Axner, E.; Johansson, A. & Chatdarong K. (2009). Detection of lipid peroxidation reaction in frozen-thawed epididymal cat spermatozoa using BODIPY 581/591 C11. *Reprod Dom Anim* 44, (Suppl. 2), 373-376.
- van der Venn, H.H.; Jeyendran, R.S.; Al-Hasani, S.; Pérez-Pelàez, M.; Diedrich, K. & Zaneveld, L.J.D. (1986). Correlation between human sperm swelling in hypoosmotic medium (hypoosmotic swelling test) and in vitro fertilisation. *J Androl* 7, 190-196.
- Vazquez, J.M.; Martinez, E.A.; Martinez, P.; Garcia-Artiga, C. & Roca, J. (1997). Hypoosmotic swelling of boar spermatozoa compared to other methods for analysing the sperm membrane. *Theriogenology* 47, 913-922.
- Verstegen, J.; Iguer-ouada, M. & Onclin K. (2002). Computer assisted semen analyzers in andrology research and veterinary practice. *Theriogenology* 57, 149-179.
- Watson, P.F. (1995). Recent developments and concepts in the cryopreservation of spermatozoa and assessment of their post-thawing function. *Reprod Fertil Dev* 7, 871-891.

- World Health Organization. (2010). WHO laboratory manual for the examination and processing of human semen. 5th ed. *WHO Press*.
- Yanagimachi, R.; Yanagimachi, H. & Rogers, B.J. (1976). The use of zona-free animal ova as a test system for the assessment of the fertilizing capacity of human spermatozoa. *Biol Reprod* 15, 471-476.
- Zambelli, D. & Cunto, M. (2006). Semen collection in cats: techniques and analysis. *Theriogenology* 66, 159-165.





*Edited by Igor I. Katkov*

Almost a decade has passed since the last textbook on the science of cryobiology, *Life in the Frozen State*, was published. Recently, there have been some serious tectonic shifts in cryobiology which were perhaps not seen on the surface but will have a profound effect on both the future of cryobiology and the development of new cryopreservation methods. We feel that it is time to revise the previous paradigms and dogmas, discuss the conceptually new cryobiological ideas, and introduce the recently emerged practical protocols for cryopreservation. The present books, “Current Frontiers in Cryobiology” and “Current Frontiers in Cryopreservation” will serve the purpose. This is a global effort by scientists from 27 countries from all continents and we hope it will be interesting to a wide audience.

Photo by Tianika / iStock

**IntechOpen**

